

PRODUCT DATASHEET

HFW-TA-01

WIRELESS HEAT DETECTOR

The HFW-TA-01 Wireless Thermal Detector is a fully intelligent device which is compatible with all of the Hyfire Wireless Translator and Expander Modules. The Hyfire range of wireless detectors are third party approved to EN54 and utilise the latest cutting edge technologies and features. The device is capable of being configured on site as either a fixed temperature, rate of rise or high temperature device type. The well proven adaptive radio signal processing algorithms ensure the highest levels of life safety and system reliability.



KEY FEATURES

- On site configuration
- High temperature option
- Fully intelligent
- 3rd party approval to EN54-5 and EN54-25
- 5 year expected battery life
- Bi-directional wireless communication
- Utilises standard low cost lithium battery technology
- 5 year product warranty
- Self-optimising wireless communication amplitude and frequency
- Colour options available

TECHNICAL INFORMATION

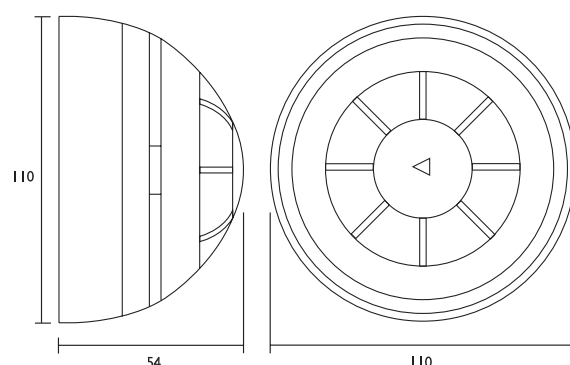

TECHNICAL SPECIFICATION

- | | |
|--|-------------------------|
| ■ Operating frequency range | 868 – 870 MHz |
| ■ Max radiated power | 5dBm (3mW) |
| ■ Radio signal modulation type | FSK |
| ■ Operating frequency channels | 7 |
| ■ Communication range with the Translator or Expander Module | ≤ 150 m (in open space) |
| ■ IP rating | 42 |
| ■ Dimensions | 110 mm x 54 mm |
| ■ Weight (without batteries) | 150g |
| ■ Primary battery | CR123A (3 V & 1.2 Ah) |
| ■ Secondary battery | CR2032A (3 V & 0.24 Ah) |
| ■ Primary battery lifespan (typical) | ≥ 5 years |
| ■ Secondary battery lifespan (typical) | ≥ 2 months |
| ■ Operating Temperature (no icing) | -10°C to +55°C |

Note: Certified device performance may vary depending on the approval body.

STANDARDS & APPROVALS

- BS EN 54-5:
Heat Detectors -
Point Detectors A1R
- BS EN 54-25:
Components using
radio links and system
requirements



0832



928j

PRODUCT DATASHEET : HFW-TA-01

LED INDICATION

The device is equipped with a tri-colour LED (red/green/amber) that provides visual indication for functional conditions and battery levels as indicated in the sections below:

OPERATIONAL STATUS INDICATIONS

Status	Amber LED	Green LED	Red LED
Switching in to operating mode		Short flashes	-
Switching in to programming mode	-	-	4 short flashes
Self-adjustment mode	-	-	1 Second On & 0.1 Second Off
Normal condition	-	-	-
Alarm condition	-	-	0.5 Second On & 0.5 Second Off
Program failure	-	-	On Constantly
Main battery fault	-	-	0.1 Second On & 5 Seconds Off
Secondary battery fault	-	0.1 Second On & 5 Seconds Off	-
Both batteries fault	-	-	Sequential bi-colour flashing
Loss of radio link with Translator/ Expander	0.5 Second On & 2 Seconds Off	-	-

COMMUNICATION QUALITY ASSESSMENT

It is possible to assess the wireless communication quality between the device and translator or expander using the built in test facility. After successful programming of the device, changing the “Program” switch to the “ON” position will set the device into test mode and the LED will start blinking according to the table below:

Communication Quality (dB)	Level	Green LED	Red LED
No connection	Fail - 0 - No Connection	-	Two flashes
Link margin is less than 10 dB	Fail - 2 - Very Poor	-	One flash
Communication with link margin from 10 dB to 20 dB	Fail - 3 - Poor	One flash	
Robust communication with link margin over 20 dB	Pass - 4	Two flashes	

Note: The “program” switch must be returned to the 1 position for normal device operation