

**AUTOMATIC TILT BACK TYRE CHANGER WITH  
DUAL ASSIST ARM**

**DEMONTE-PNEUS AUTOMATIQUE AVEC BRAS  
D'APPOINT A DOUBLE FONCTION**

# S 226 Pro

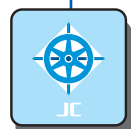
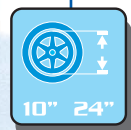

Approved\*



\* Version available upon request / Version disponible sur demande

# S 226 Pro



## STANDARD FEATURES - DONNEES TECHNIQUES

Rim clamping from outside <i>Blocage jante de l'extérieur</i>	10" - 22" *
Rim clamping from inside <i>Blocage jante de l'intérieur</i>	12" - 24" *
Max. tyre diameter <i>Diamètre maxi. roue</i>	1100 mm (43")
Max. tyre width <i>Largeur maxi. roue</i>	390 mm (15")
Bead breaker cylinder force at 10 Bar <i>Force vérin décolleur à 10 Bar</i>	30800 N
Operating pressure <i>Pression de service</i>	10 Bar (145 Psi)
Power supply <i>Alimentation</i>	110 Volt, 1 vitesse
Motor power <i>Puissance moteur</i>	1 Hp
Rotation speed <i>Vitesse de rotation</i>	7 rpm
Pre-set tyre inflating pressure <i>Pression de gonflage maxi.</i>	3,5 Bar (50 Psi)
Net weight <i>Poids net</i>	310 kg

\* Adjustable jaws can be pre-set in 3 different holes on slides, to start clamping range from 10", 11" or 12". Tabletop cylinder stroke = 10".  
\* Des griffes de blocage réglables peuvent être préréglées sur les patins grâce à 3 trous différents, permettant de bloquer les roues de 10", 11" ou 12". Course du vérin du plateau centreur = 10".

## DIMENSIONS - DIMENSIONS

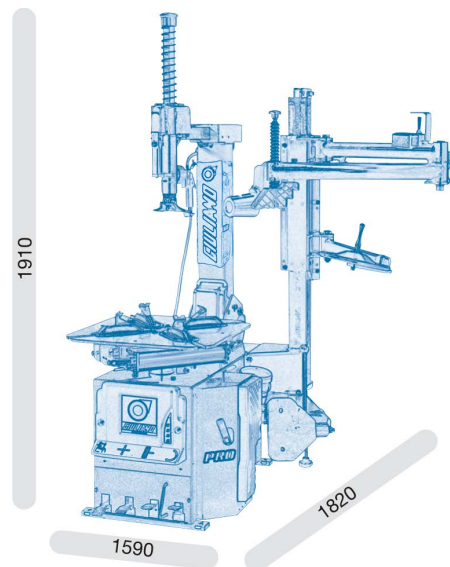

## STANDARD ACCESSORIES - ACCESSOIRES STANDARD

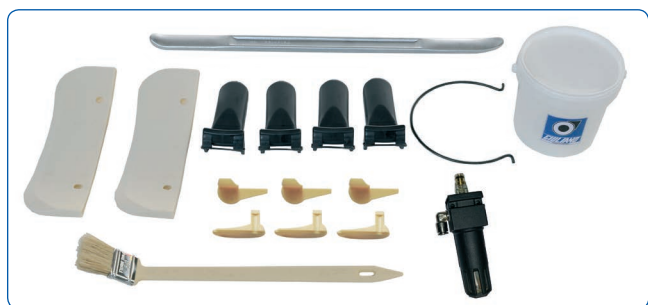

For low-mid volume shops, garages and repair shops.

*Pour les ateliers gérant de faibles et moyens volumes, les garages et les ateliers de réparation.*

## FUNCTIONS - CARACTERISTIQUES

Tilting tower, sliding horizontal arm with Ø 41 mm operating arm  
*Bras vertical basculant, bras horizontal coulissant avec bras porte outil hexagonal de Ø 41 mm*

Bead breaker double effect Cylinder Ø 200 mm  
*Verin détalonneur de Ø 200 mm à double effet*

Reinforced Chassis  
*Châssis renforcé*

Tabletop thickness 12 mm  
*Plateau centreur ayant une épaisseur de 12 mm*

Fitting head designed for both standard and low profiled tyre applications  
*Tête de montage conçue pour les pneus standards ainsi que pour les pneus à profil rabaisé*

Tyre inflation by pedal  
*Dispositif de gonflage par pédale*

Equipped with HP2 dual assist arm  
*Equipé du bras d'appoint avec double fonction HP2*

Suitable for Tubeless tyre bead seating system (optional)  
*Système de gonflage Tubeless GUN (en option)*

"Easy Access" extractable pedal box for quick service  
*Pédalier amovible et facilement accessible pour les opérations d'entretien rapide*



Profession: Passion

Giuliano Industrial S.p.A: Via Guerrieri, 6 - 42015 CORREGGIO (RE) ITALY  
Tel. +39 0522 731111 - Telefax +39 0522 633109 - E-mail: info@giuliano-automotive.com  
Internet: www.giuliano-automotive.com

Since 1976

