

Sivoia® QS  
Installation  
Instructions

**roller 64™  
fascia and  
top/back cover**

 **LUTRON®**

# Sivoia® QS | roller 64™ fascia and top/back cover

## Installation Instructions (please leave for occupant)

### Tools Required:

Tape Measure  
Wire Cutter/Stripper  
Pliers  
#2 Phillips Screwdriver

1/4 in. Hex-Head Driver  
Level  
Power Drill

### Box Contents:

(1) Sivoia QS roller 64



(2) Bracket Leveling Spacers

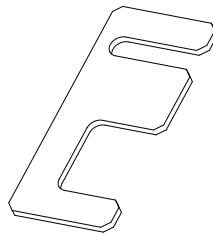

(2) Cable Tie Anchors

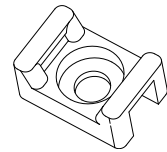

Fascia Brackets with Retaining Screws

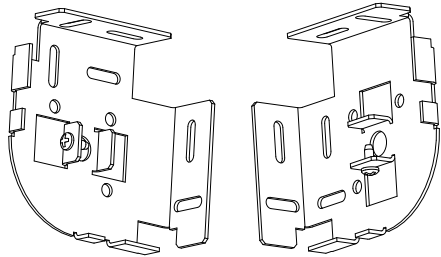

(1) 4 Pin Terminal Block

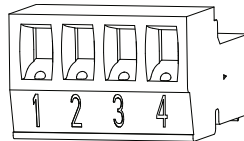

(5) Mounting Screws  
(#8x1-3/4 in. (#8x44 mm) Hex Head Screws)

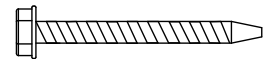

(1) Top/Back Cover (if applicable)

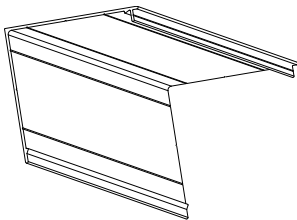

(2) 4 in. (102 mm) Cable Ties



(1) Fascia

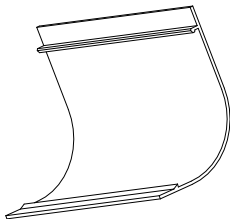

(2) Fascia Endcaps (if applicable)

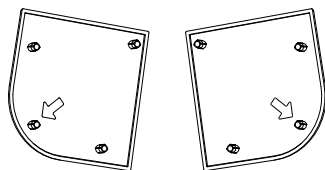

(1) Screwdriver



(1) Programming Stylus



# Sivoia® QS | roller 64™ fascia and top/back cover

## Installation Instructions (continued)

**Warning:** Incorrect installation can lead to severe injury, follow all installation instructions.

**Notes:**

- The *Sivoia* QS roller 64 must be used only with window treatments approved by Lutron®.
- There must be a clearance of at least 1.3 feet (0.4 meters) between the fully lowered system and any permanent object.
- Installation shall be executed by a qualified electrician according to national wiring rules.
- **Codes:** Install in accordance with all local and national electrical codes.
- **Environment:** Ambient operating temperature: 32 to 104 °F (0 to 40 °C), 0 to 90% humidity, non-condensing. Indoor use only.

# 1 Confirm system dimensions

## 1.1

Compare system dimensions on the package label with the window dimensions to verify appropriate window/shade combination.

This information can also be found on the shade tube by lowering the fabric down far enough to expose the tube.

Package label

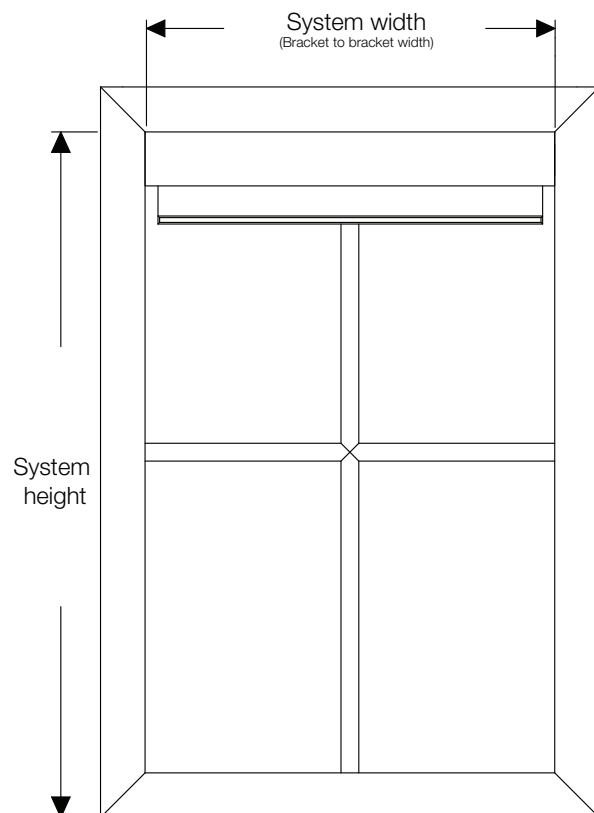
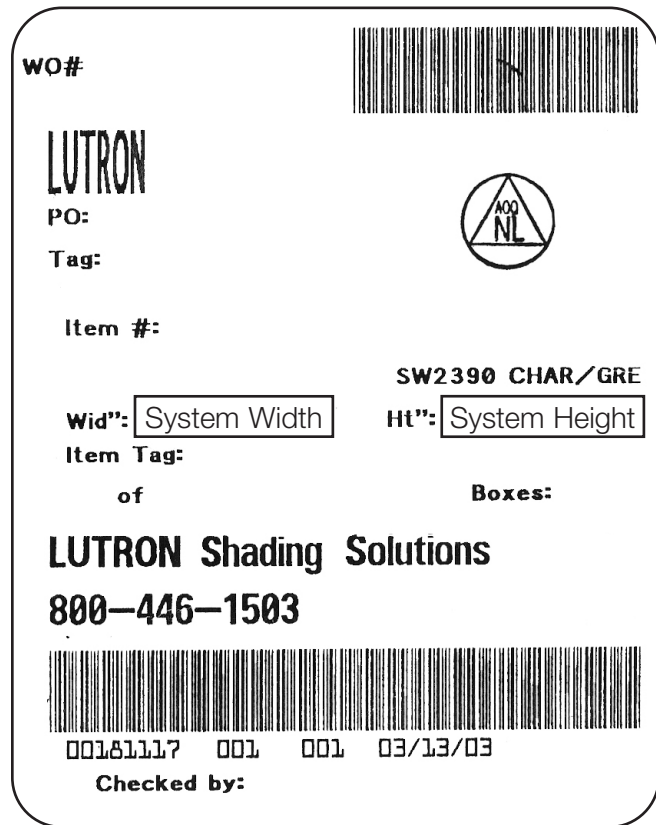

## 2

## Mount top/back cover

### 2.1

Pre-drill top/back to allow clearance for the entry of wires without interfering with the bracket. Follow figure below for suggested hole locations.

- Hole should be large enough to allow adjustment during install without pinching the wire.
- Cable should exit from EDU (Electronic Drive Unit) side of the system.

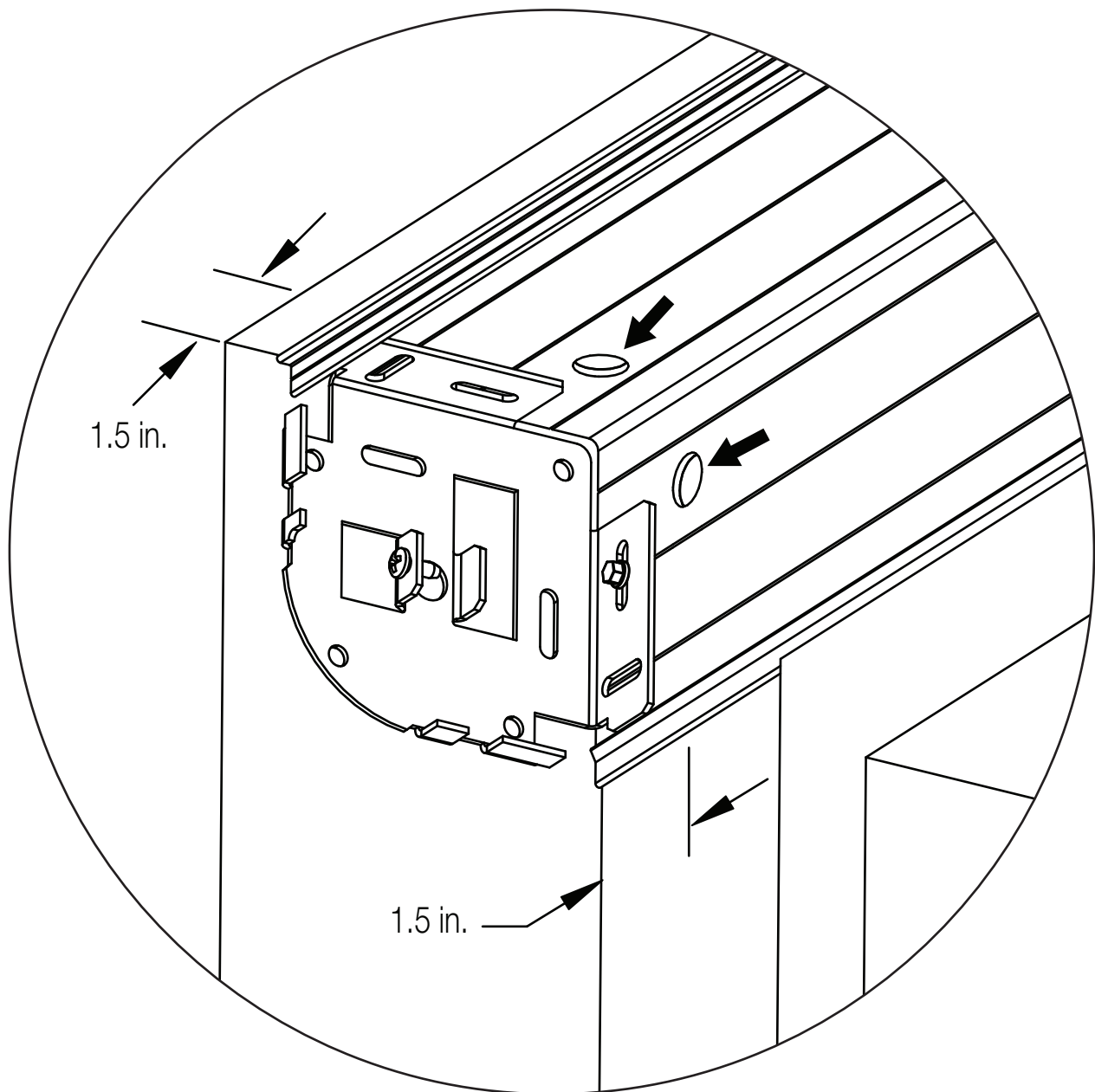

## 2

## Mount top/back cover (continued)

### 2.2

Verify mounting surface is level/plumb before attaching top/back cover.

**Note:** Top/back cover may rub fabric if installed with an improper tilt or may cause flap to fall.

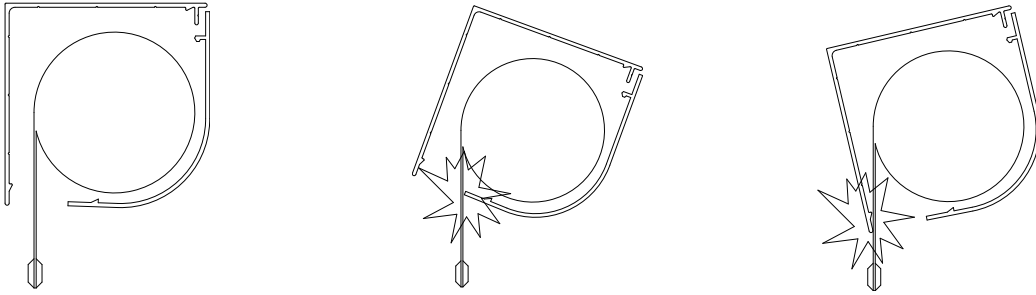

### 2.3

Mount the top/back cover using the appropriate fasteners. The ceiling side of the top/back cover is the side with the larger of the two snapping tabs.

**Notes:**

- The clearance hole for the wires and the screws must be at least 1.5 in. (38 mm) from system end to avoid mounting brackets.
- Be sure to pull cable through hole in pocket while mounting.
- The top/back cover should be mounted to support at least 300 lbs (136 kg). The fasteners provided may not be appropriate for use in all applications.

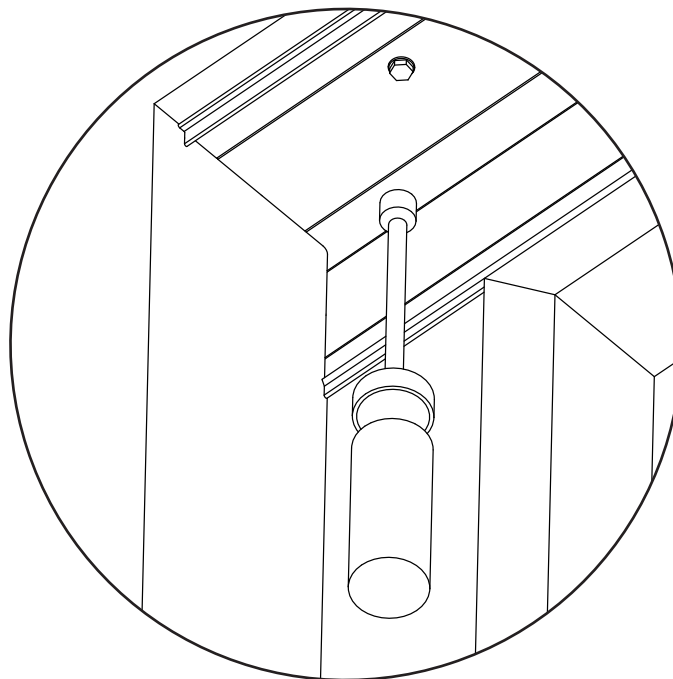

# 3

## Position the mounting brackets

### 3.1

Mark the location of the mounting brackets so they are centered over the window.

**Notes:**

- Bracket to bracket distance = fabric width + 1.5 in. (38 mm) = system width.
- For a ceiling and jamb mount, allow clearance to prevent fabric from rubbing against trim, window, top treatment, etc.
- Wall mount may require blocks to clear trim.

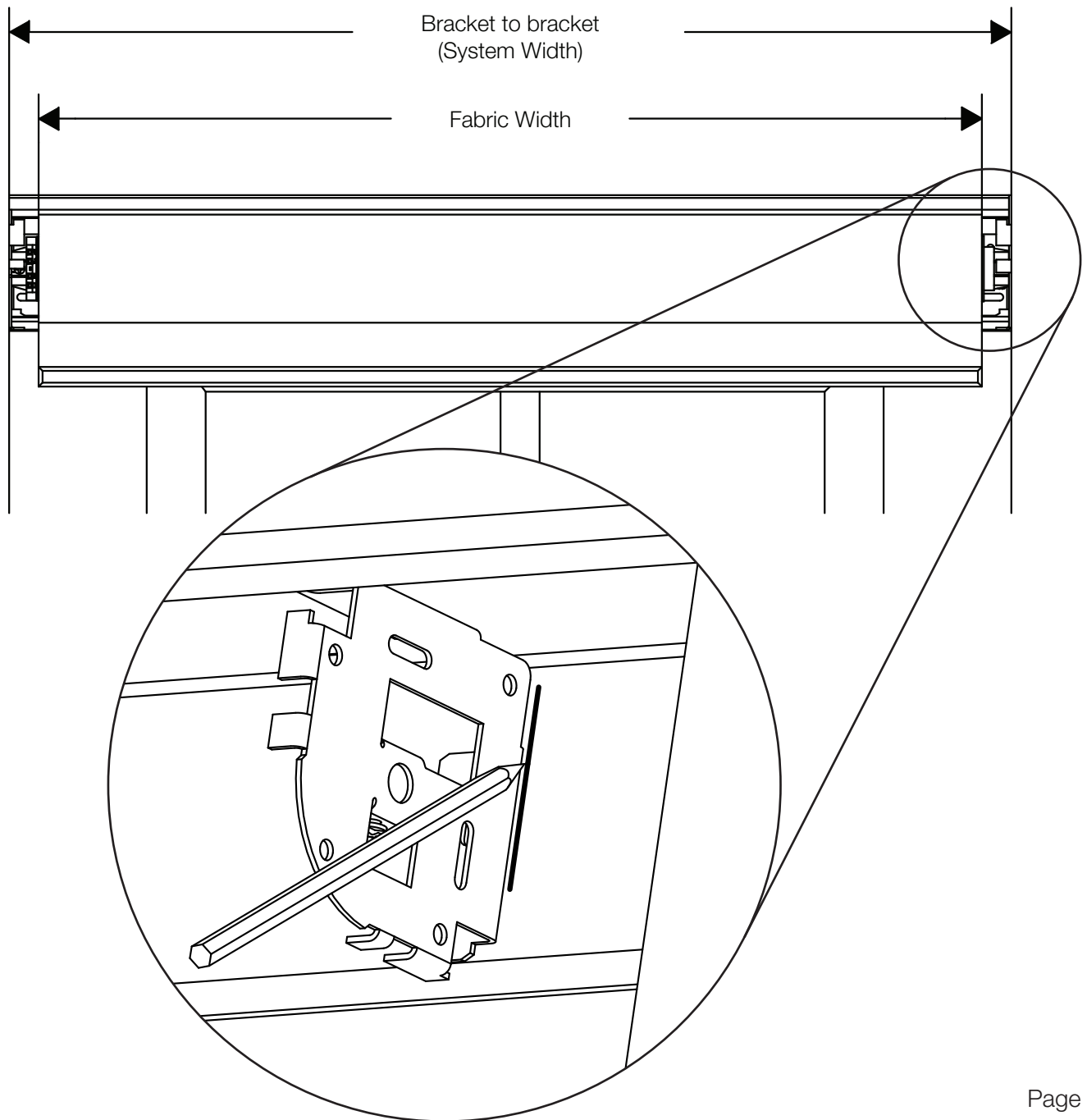

# 4

## Install fascia brackets

**Note:** If not using a top/back cover, go to step 4.2

### 4.1

Hook the top of the fascia bracket behind the top triangular tab of the top/back cover. Then rotate the bracket until it snaps onto the bottom tab of the top/back cover.

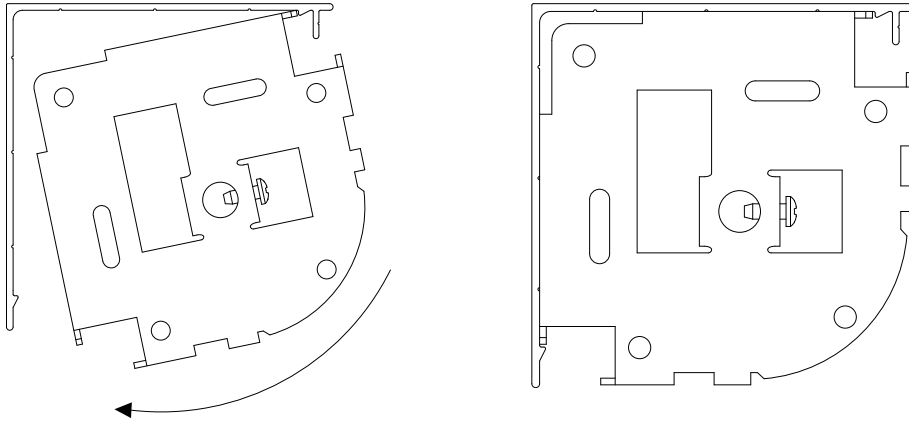

### 4.2

Mount the brackets.

**Notes:**

- Put screws in both slots of either a wall mount or ceiling mount.
- The brackets should be mounted to support at least 300 lbs (136 kg). The fasteners provided may not be appropriate for use in all applications.

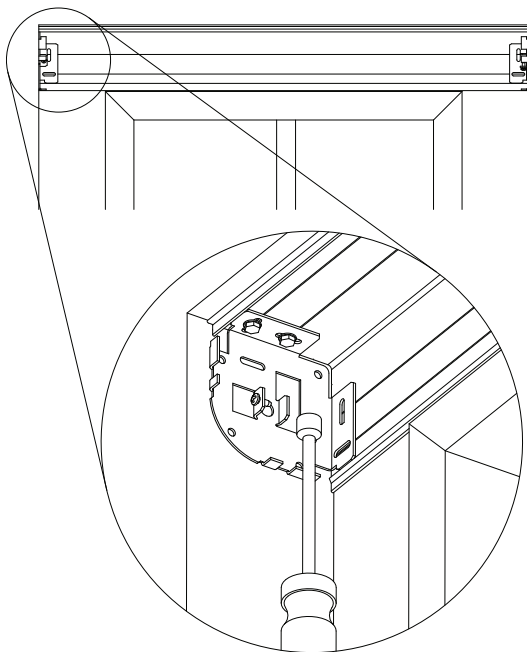



## 5 Wire 4-pin terminal block

### 5.1

Strip 2 in. (50 mm) of the jacket off the cable run from the wall.

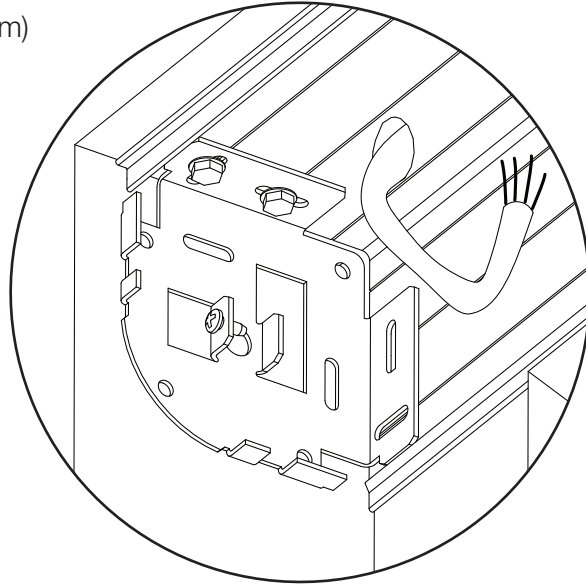

### 5.2

Wire 4-Pin terminal block (provided) to cable using the included screwdriver. Make sure to tighten the screws tightly and that no insulation is inside of the terminal block.

#### Notes:

- The EDU connector will support wire sizes from AWG 12 (2.5 mm) to AWG 26 (0.2 mm). See the instruction sheet for your power supply to choose an appropriate wire size for your application.
- Strip insulation from wires so that 0.25 in. (6.3 mm) of bare wire is exposed.

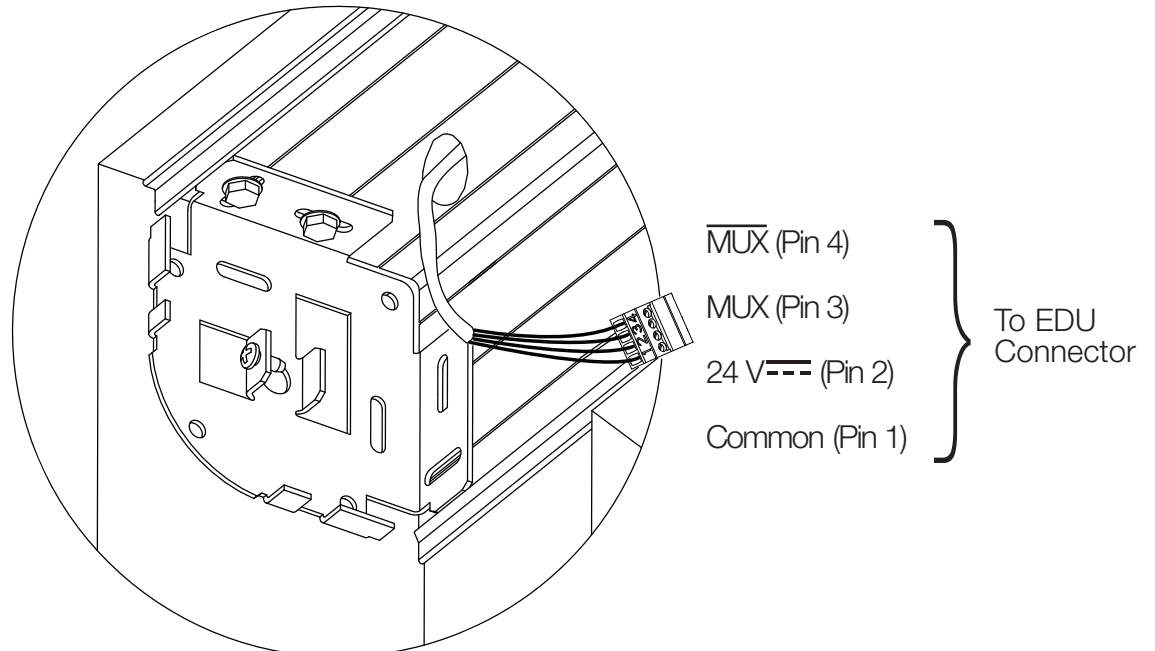

# 6

## Orient the buttons and wiring

### 6.1

For the following bracket and button orientations, route the wires as shown.

**Notes:**

- The buttons should be accessible when the shade is installed.
- Make sure the wires are not pinched or damaged.
- The wires may go in either of the indicated slots.

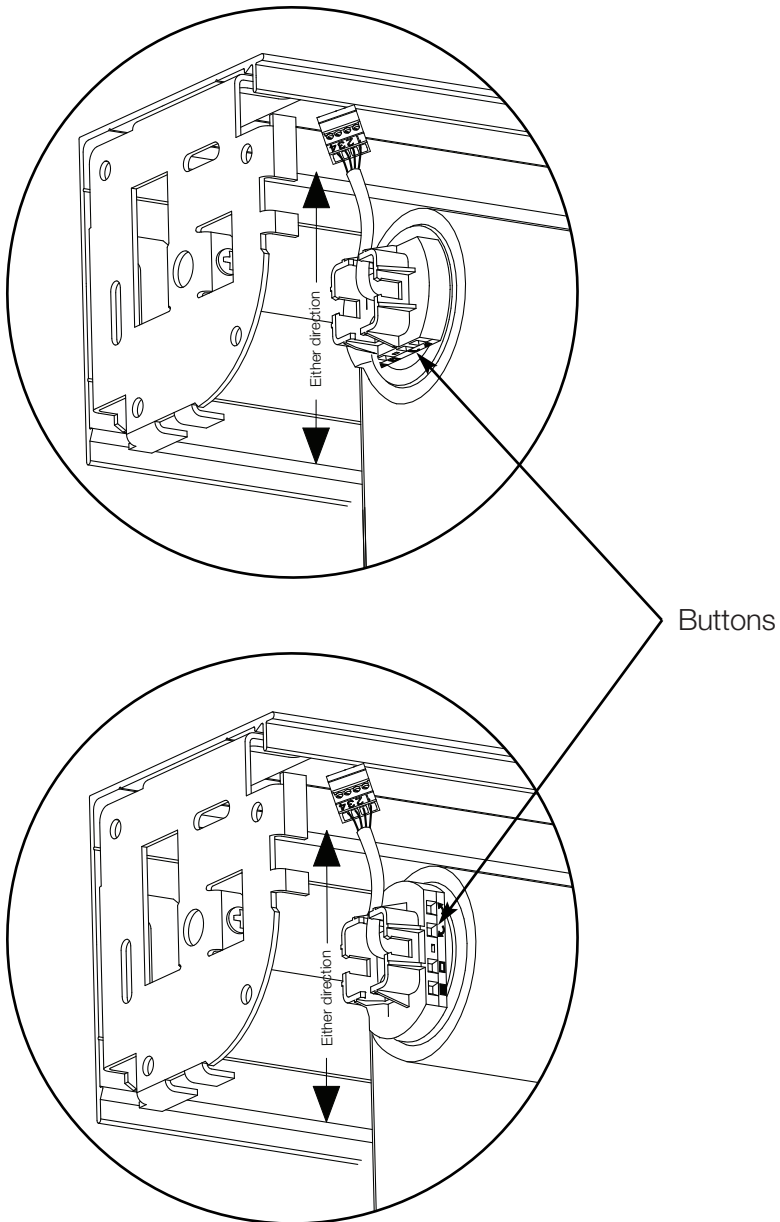

## 7 Mount the shade

### 7.1

Install the idler side of the shade onto its bracket.

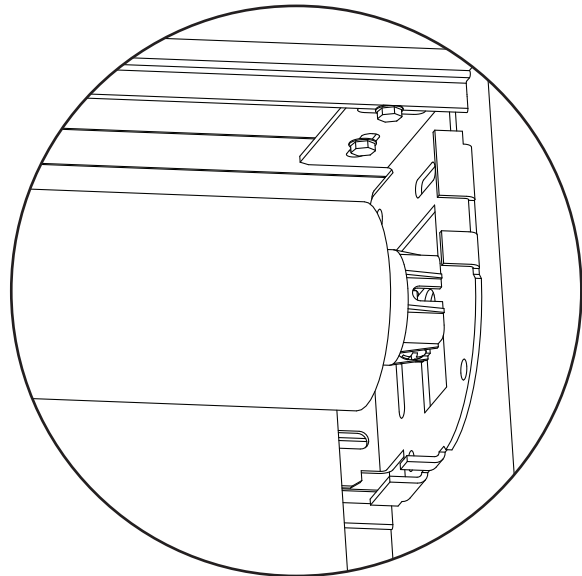
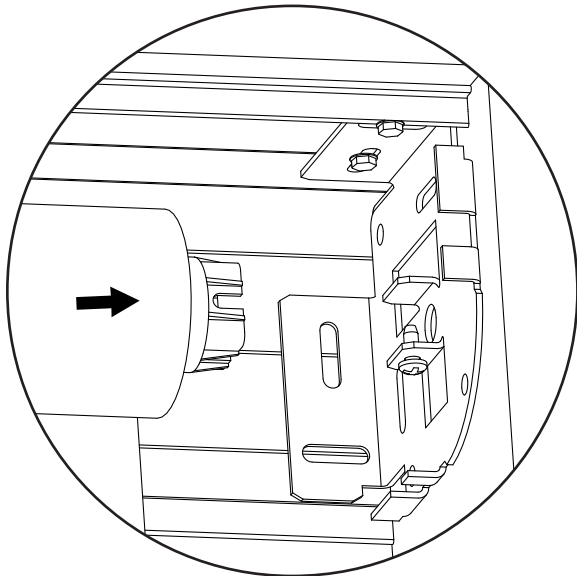

### 7.2

Depress the spring-loaded idler (shown in 7.1) and install the EDU side of the shade onto its bracket.

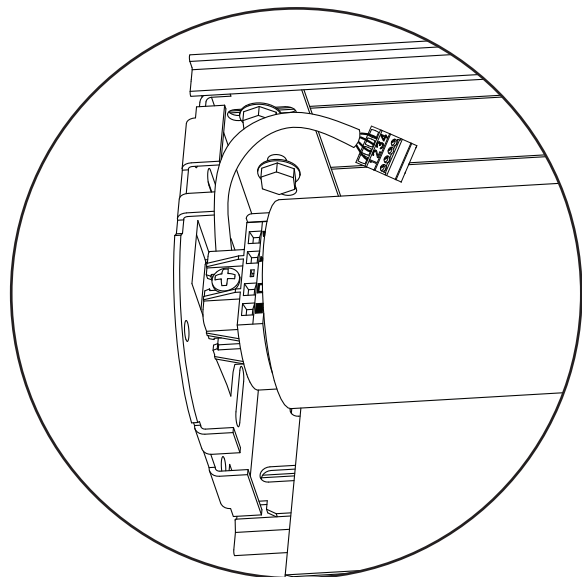
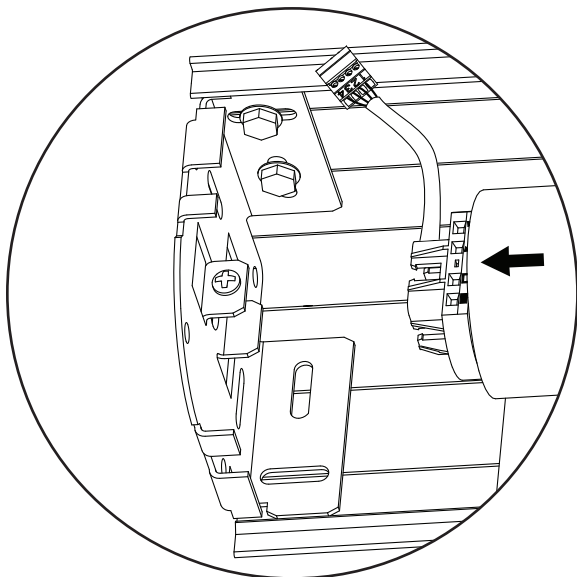

## 8 Adjust the shade

### 8.1

Ensure that the shade is level and centered.

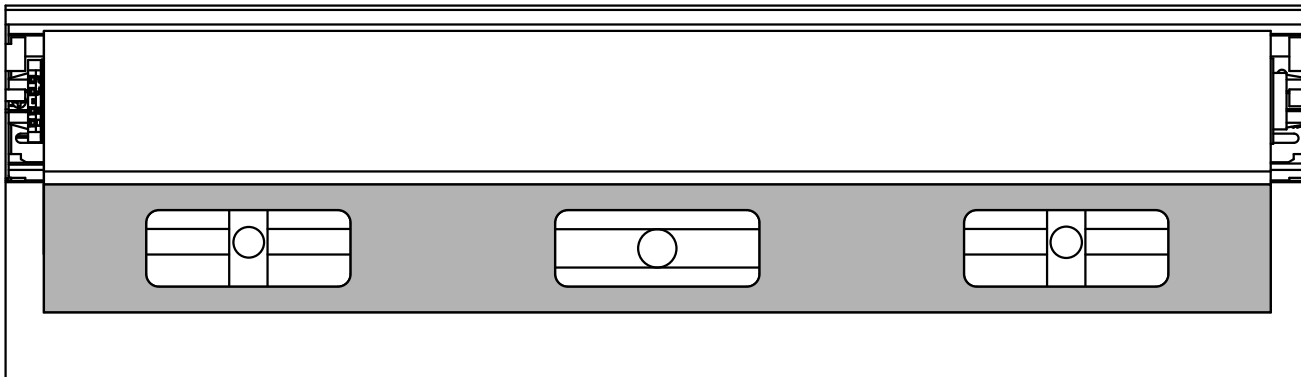

### 8.2

Adjust shade by removing the necessary screws and moving the brackets as needed, or installing bracket leveling spacers. You may have to remove the shade to access the bracket screws.

**Note:**

- If using a top/back cover, only the width is adjustable.

### 8.3

Reinstall and tighten the screws.

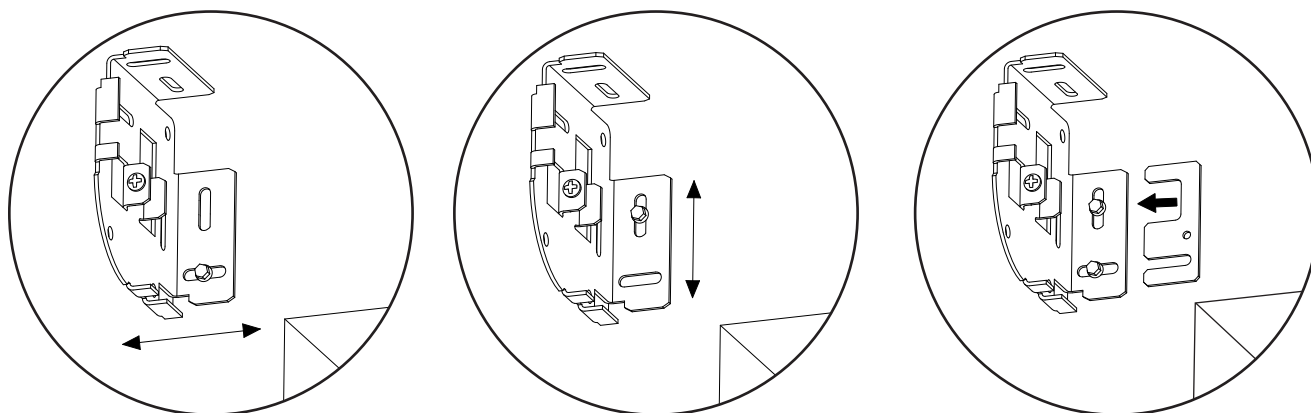

# 9

## Connect terminal blocks

### 9.1

Plug 4-pin terminal block on cable into EDU terminal block attached to shade bracket.

### 9.2

Dress wires to ensure fabric does not rub.

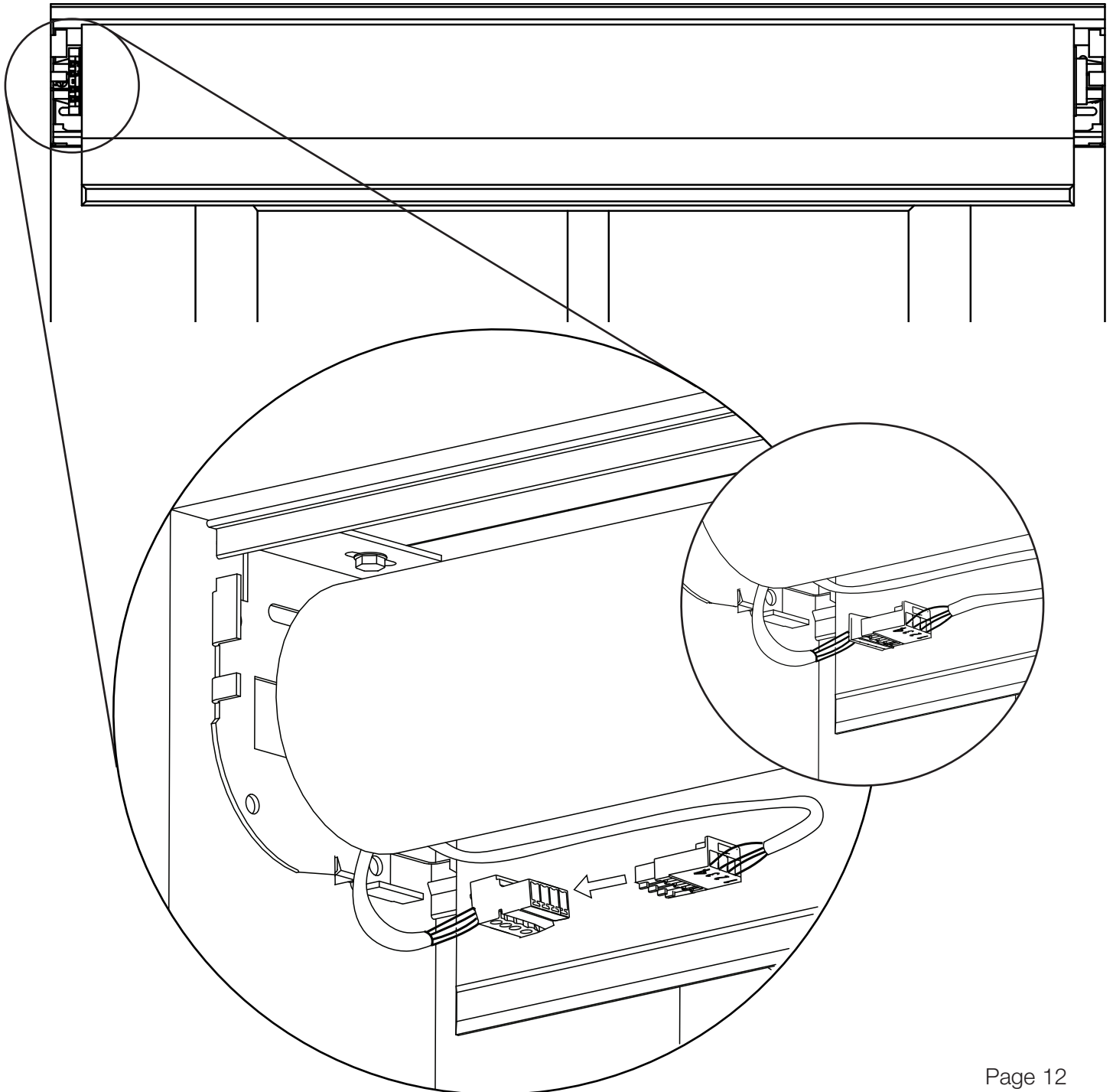

# 10 Secure and check the shade

## 10.1

Be sure to tighten retaining screws in each bracket to secure the shade.

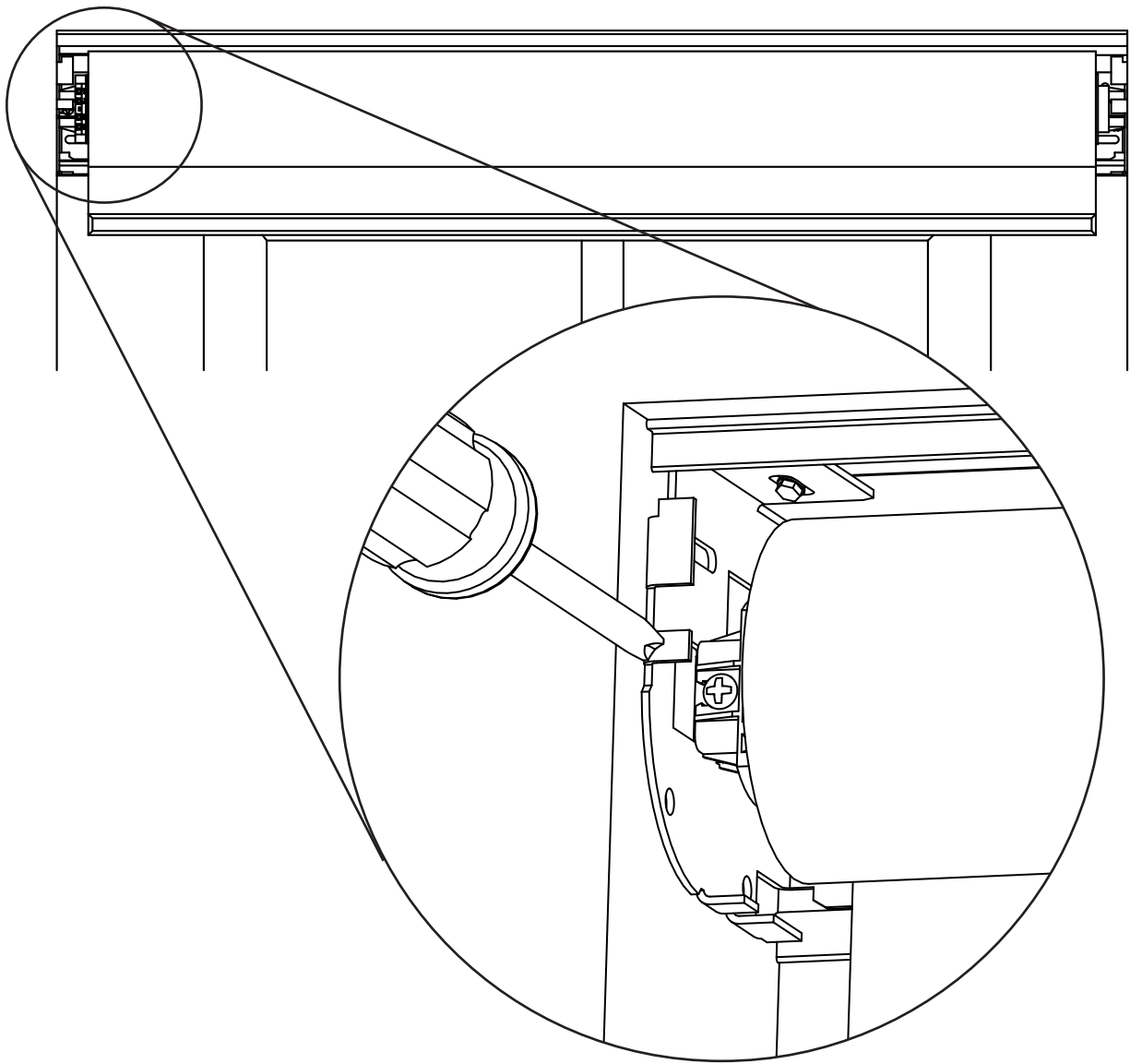

## 10.2 Secure and check the shade (continued)

Use the programming stylus to run the shade up and down using the adjustment buttons (↕), re-level if needed.

**Observe:** Pay careful attention to the shade roll up to ensure that it does not telescope extremely to one side or the other.

**Tip:** Slight telescoping is normal. However, if the shade is telescoping severely to one side and it is level, press the “close limit button” (■), and lower the shade all the way down using the adjustment buttons (↕). Place a piece of tape on the side of the tube that the fabric is telescoping away from. When finished press the “close limit button” (■) once. This technique is referred to as “shimming”. The shade will always track towards the side that the tape (shim) is placed on.

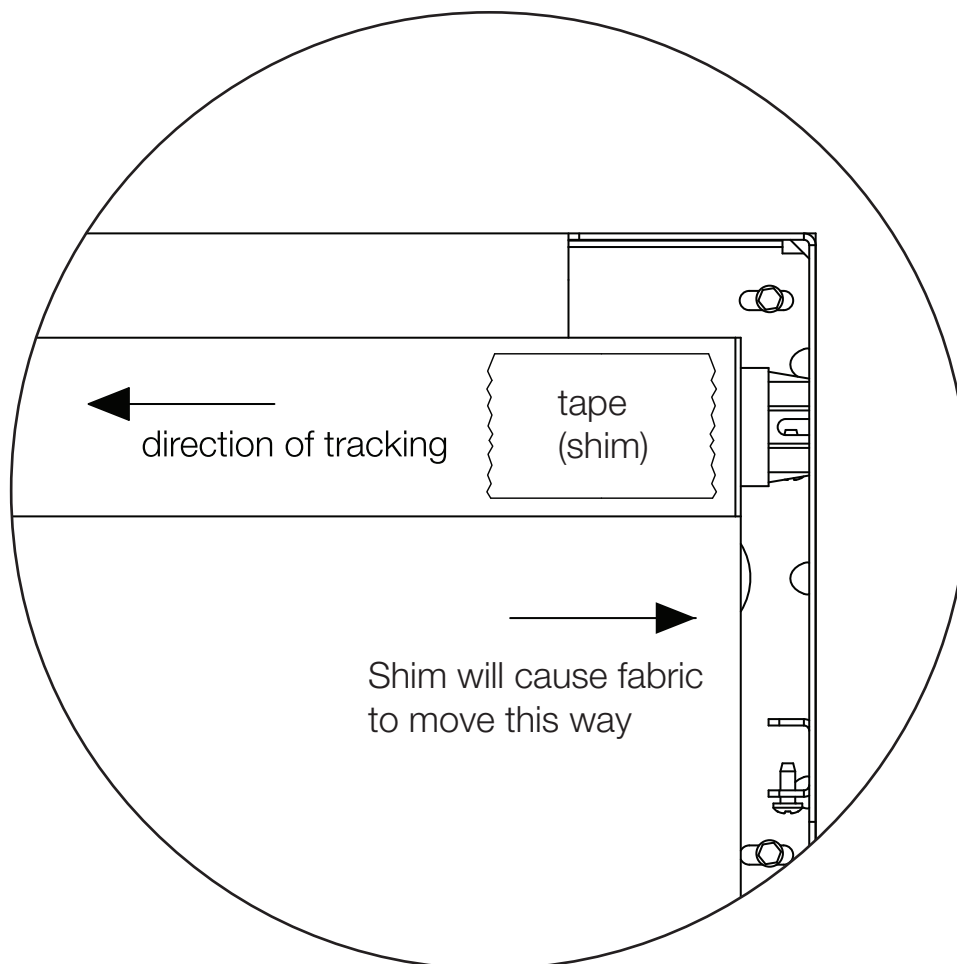

# 11 Setting limits from the EDU

## Setting the open limit from the EDU



The open and close limits define the top and bottom of the shade, and are used to determine which direction the shade must turn in order to raise or lower. Refer to the keypad's instruction sheet to set the limits remotely.

### 11.1

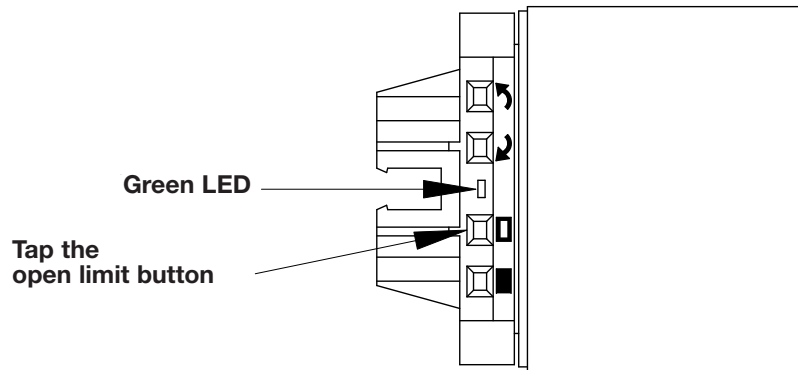
Tap the "open limit button" (  ). The green LED on the roller 64 EDU will turn on steady, indicating that the EDU is in "set open limit mode."



### 11.2

Adjust the position of the EDU to the desired open limit using the clockwise and counterclockwise buttons (   ).

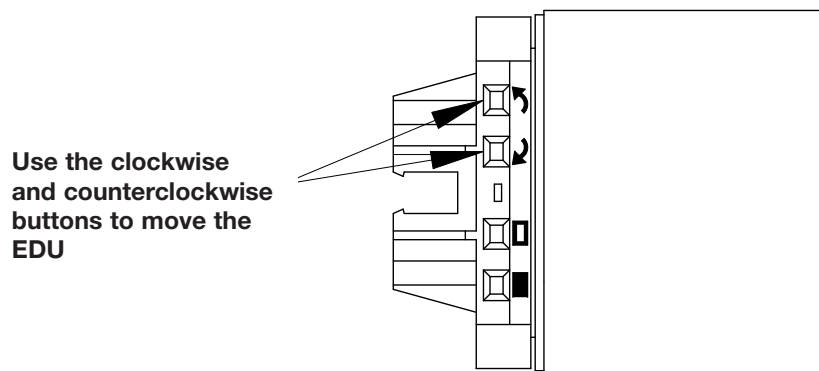

### 11.3

Press and hold the "open limit button" (  ) for 5 seconds. The green LED on the roller 64 EDU will flash for 2 seconds, then go dark, indicating that the current position has been stored as the open limit.

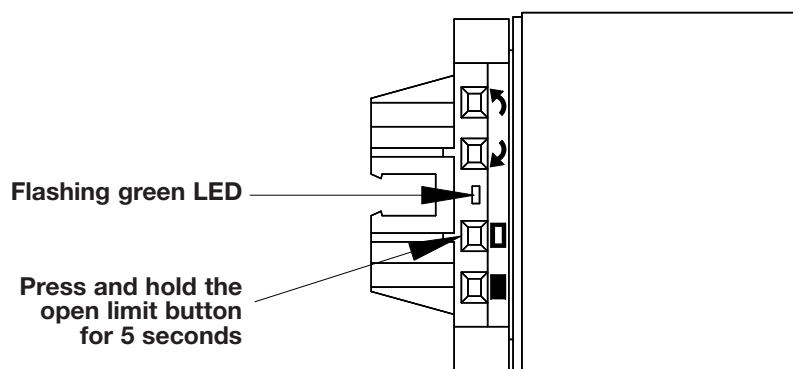



# 11 Setting limits from the EDU (continued)

## Setting the close limit from the EDU

### 11.4

Tap the “close limit button” (■). The green LED on the roller 64 EDU will turn on steady, indicating that the EDU is in “set close limit mode”.

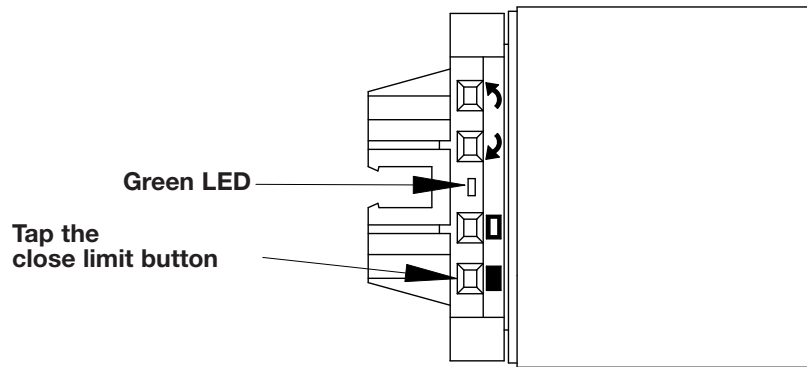

### 11.5

Adjust the position of the EDU to the desired close limit using the clockwise and counterclockwise buttons (↻↺).

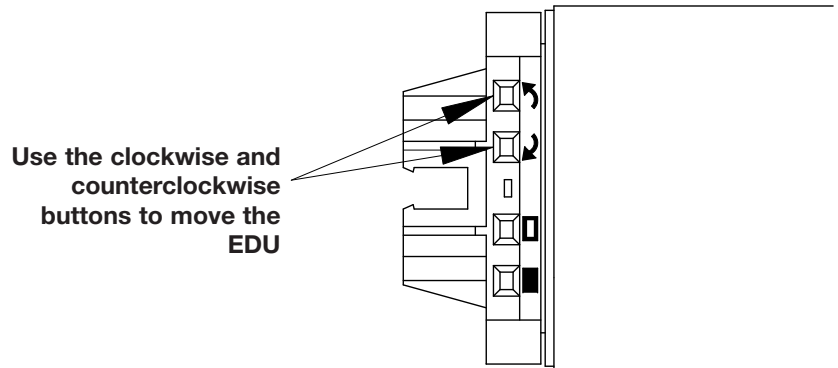

### 11.6

Press and hold the “close limit button” (■) for 5 seconds. The green LED on the roller 64 EDU will flash for 2 seconds, then go dark, indicating that the current position has been stored as the close limit.

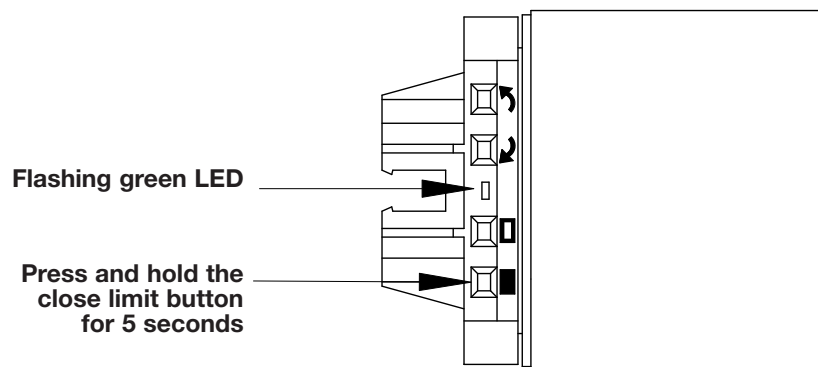

## 12 Verify Limits

### 12.1

Verify the Open Limit by double-tapping the Open Limit (  ) button. The shade will travel to the Open Limit.

### 12.2

Verify the Close Limit by double-tapping the Close Limit (  ) button. The shade will travel to the Close Limit.

# 13 Verify Communications

## 13.1

Enter "Link Diagnostics Mode" by pressing and holding the "Close Limit Button" (■) on the EDU for 5 seconds. The green LED will flash quickly for two seconds then turn on steady, indicating the EDU is ready to begin verifying communications with other devices.

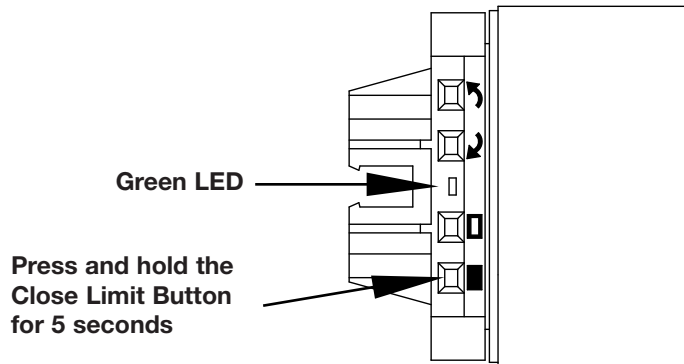

## 13.2

Initiate "Link Diagnostics Mode" by tapping the "Adjust Counterclockwise Button" (↺). The green LED will begin to flash quickly (8 times per second), and the EDU will begin to raise and lower a short distance ("wiggle").

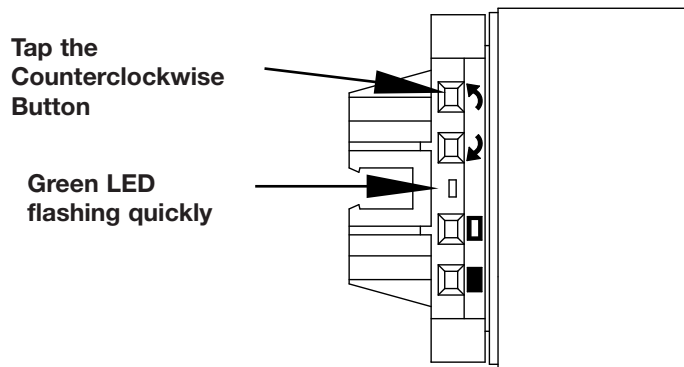

## 13.3

This EDU is now trying to communicate with **all** other devices. All EDUs communicating on the link will wiggle and flash their green LED. Verify that all other devices are able to communicate with this device. If you discover any EDUs that are not wiggling, verify that the EDU is powered and wired properly. "Link Diagnostics Mode" will automatically time out after 10 minutes.

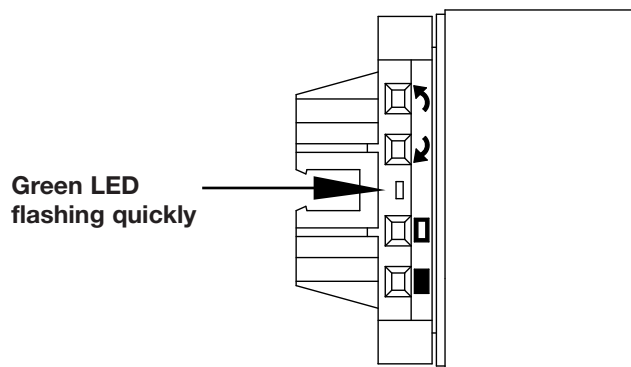

## 13.4

Exit "Link Diagnostics Mode", by pressing and holding the "Close Limit Button" (■) on the EDU for 5 seconds. All EDUs on the link will stop wiggling and their LED will turn off.

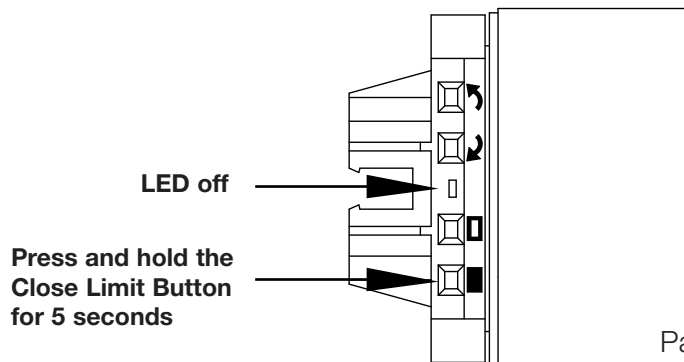

# 14 Programming | Restoring Default Settings

## Returning an EDU to its Factory Default Setting

Returning an EDU to its Factory Defaults will clear out any programming to keypads, but will not affect the Limits.

### 14.1

Press and hold the “Close Limit Button” (■) on the EDU for 5 seconds. The green LED on the EDU will flash quickly for two seconds then turn ON steady.

Flashing green LED  
Press and hold the Close Limit Button for 5 seconds

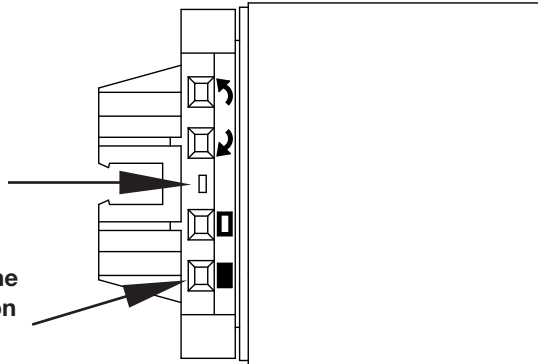

### 14.2

Press and hold the “Open Limit Button” (□) for 5 seconds. The green LED on the EDU will flash then turn ON steady.

Flashing green LED  
Press and hold the Open Limit Button for 5 seconds

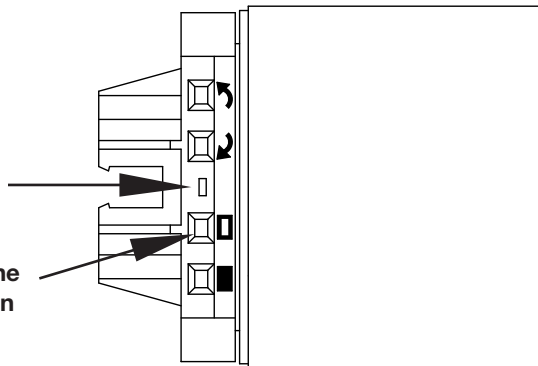

### 14.3

Press and hold the “Clockwise Button” (↻) for 5 seconds. The green LED on the EDU will flash then turn ON steady.

Press and hold the Clockwise Button for 5 seconds  
Flashing green LED

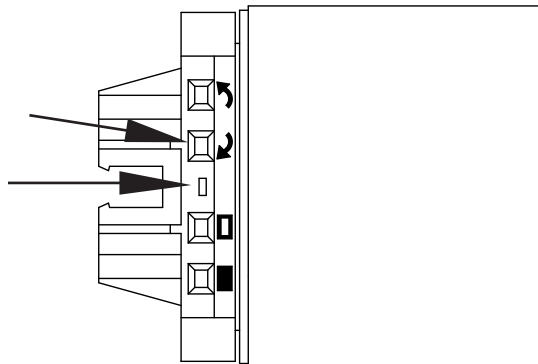

### 14.4

Press and hold the “Counterclockwise Button” (↺) for 5 seconds. The LED on the EDU will flash blue briefly, and then the EDU will reset. The EDU is now restored to Factory Default Settings. The Limits will not be affected.

Press and hold the Counterclockwise Button for 5 seconds  
LED will flash

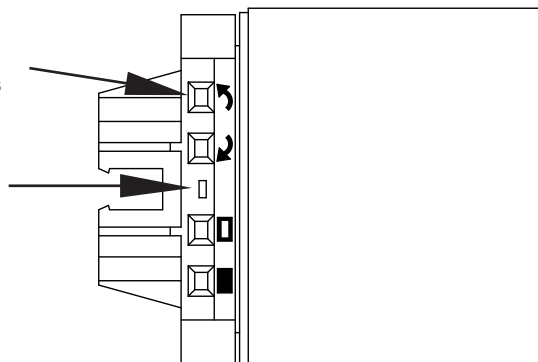

## 15 Attach fascia

**Note:** Fascia and endcaps are installed after the shade is mounted and programmed.

### 15.1

Hook the top tab of the fascia on the bracket as shown.

### 15.2

Swing the fascia down toward the shade, and snap the triangular lip onto the bracket.

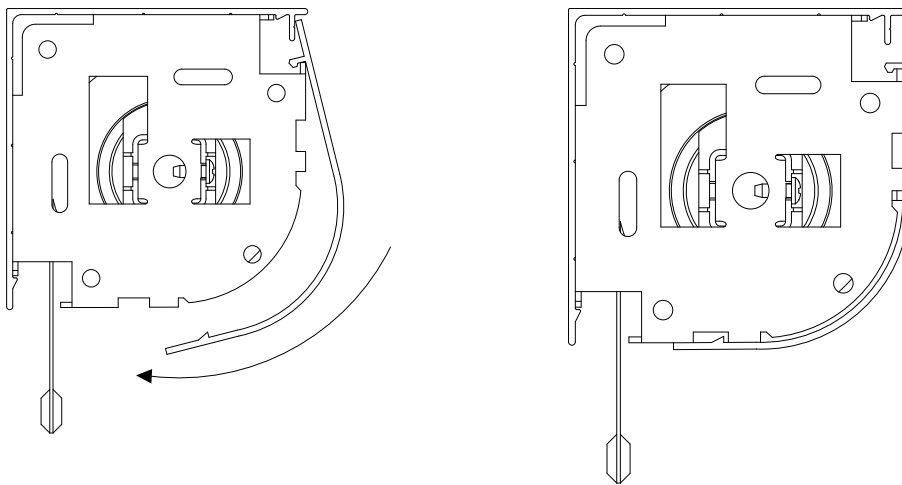

### 15.3

Ensure the fabric does not rub on anything.

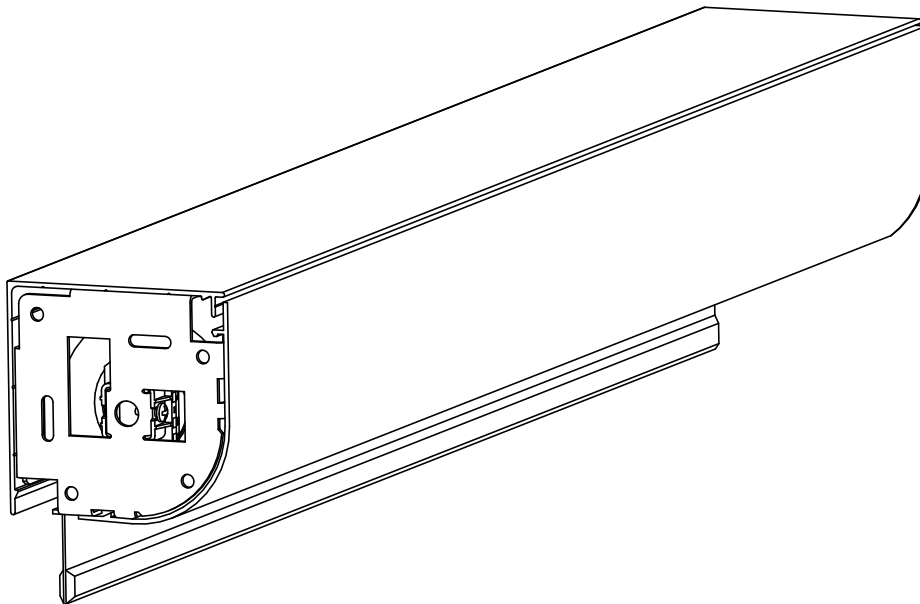

## 16 Install fascia endcaps

### 16.1

Snap the fascia endcap onto the fascia bracket by aligning the pins with the holes on the bracket, and pressing it into place.

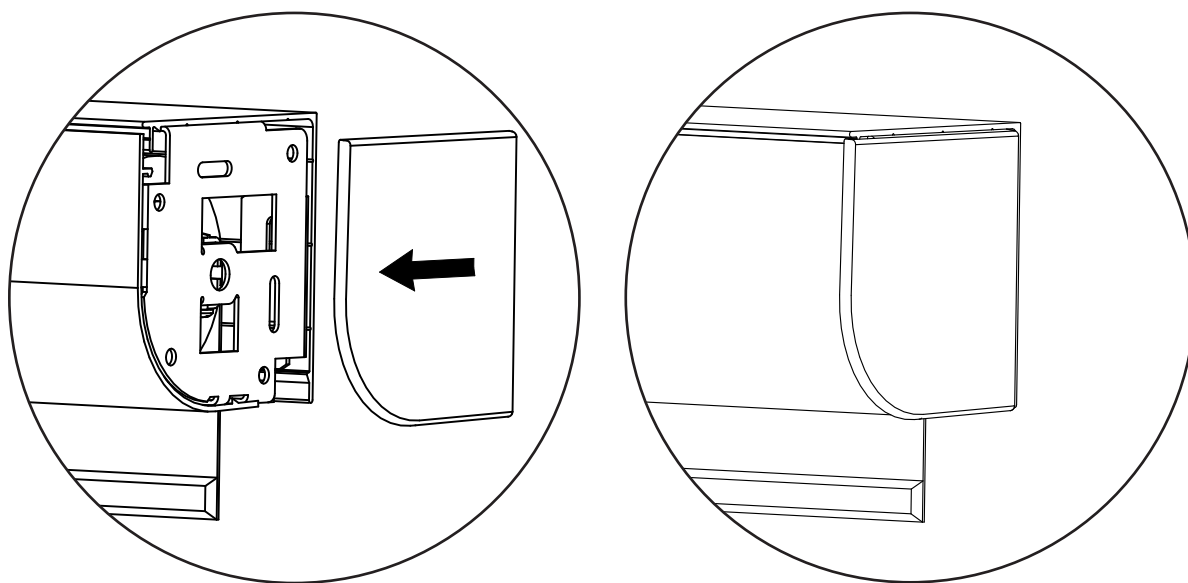

<u>Symptom</u>	<u>Solution</u>
Shade will not move using adjustment buttons on EDU...	<p>...EDU is not powered - check EDU Power by unplugging and re-plugging in EDU. LED should flash for 5 seconds.</p> <p>...Shade is caught on something - free shade.</p>
Shade does not fully open or fully close...	<p>...Limits have been set incorrectly - refer to “set open limit” and “set close limit” sections.</p> <p>...Shade fabric is caught on something - free shade.</p>
Fabric not level...	<p>...Check that brackets are mounted level.</p> <p>...Check that fabric is tracking correctly on the shade tube.</p>
Fabric not centered over window...	<p>...Check that brackets are centered.</p>
Shade does not move smoothly...	<p>...Check for binding of shade fabric on side channels.</p> <p>...Check fabric tracking.</p>
EDU does not move, and the LED is blinking red slowly four times, and then turning off for 4 seconds...	<p>...The EDU has reached its maximum run-time. Wait 20 minutes before attempting to move the shade.</p>
EDU has its red LED on steady...	<p>...This EDU is unable to establish communication. Check your wiring.</p>
EDU is blinking its blue LED quickly...	<p>...This EDU does not have enough power to operate properly. Refer to the power supply's instruction sheet to verify your installation.</p> <p>...This EDU is being powered by an AC supply. Use an approved 24 V --- supply, such as the QSPS-P1-10-60.</p>
Keypad does not control shade or sends it to the wrong level...	<p>...Limits have been set incorrectly - refer to “set open limit” and “set close limit” sections.</p> <p>...Refer to the keypad instruction sheet for programming instructions.</p>

# Limited Warranty

## SCOPE

This limited warranty (“Warranty”) covers the Lutron supplied (a) Sivoia® QS Shade System (“Sivoia® QS Shade System”), (b) Sivoia QED® Shade System (“Sivoia QED® Shade System”), (c) manual shade system and (d) alternating current or a/c shade system (each of the foregoing being a “System”). Customer acknowledges and agrees that use of the System constitutes acceptance of all terms and conditions of this Warranty.

## LIMITED WARRANTY

Subject to the exclusions and restrictions described below, Lutron warrants that each System will be free from manufacturing defects from the date of shipment by Lutron for a period of (a) one year as to the wall controls, interfaces and system accessories of the Sivoia QS Shade System (“External Sivoia QS Components”) and (b) eight years as to the other Systems and the Roller Shade EDU, shade fabric and shade hardware of the Sivoia QS Shade System. If any manufacturing defect exists in the External Sivoia QS Components, so long as Customer promptly notifies Lutron of the defect within the one year warranty period and, if requested by Lutron, returns the defective part(s), Lutron will, at its option, either repair the defective part(s) or provide comparable replacement part(s). If any manufacturing defect exists in any of the components of a System other than the External Sivoia QS Components, so long as Customer promptly notifies Lutron of the defect within the eight year warranty period and, if requested by Lutron, returns the defective part(s), Lutron will, at its option, either repair the defective part(s) or issue a credit to the Customer against the purchase price of

Number of Years from Date of Shipment	Percentage of Cost of Replacement Parts Credited by Lutron
Up to 2	100%
More than 2 but not more than 5	50%
More than 5 but not more than 8	25%
More than 8	0%

comparable replacement part(s) purchased from Lutron as provided below:

Replacement parts for the System provided by Lutron or, at its sole discretion, an approved vendor may be new, used, repaired, reconditioned, and/or made by a different manufacturer.

## EXCLUSIONS AND RESTRICTIONS

This Warranty will be void, and Lutron and its suppliers will have no responsibility under this Warranty, if Lutron or its representatives cannot access any components of the System to inspect, diagnose problems with or repair the System or any of its components as a result of concealment or inaccessibility of such components within a building structure.

This Warranty does not cover, and Lutron and its suppliers are not responsible for:

1. Damage, malfunction or inoperability diagnosed by Lutron or a Lutron approved third party as caused by normal wear and tear, abuse, misuse, incorrect installation, neglect, accident, interference or environmental factors, such as (a) use of incorrect line voltages fuses or circuit breakers; (b) failure to install, maintain and operate the System pursuant to the operating instructions provided by Lutron and the applicable provisions of the National Electrical Code and of the Safety Standards of Underwriter's Laboratories; (c) use of incompatible devices or accessories; (d) improper or insufficient ventilation; (e) unauthorized repairs or adjustments or alterations; (f) vandalism; (g) an act of God, such as fire, lightning, flooding, tornado, earthquake, hurricane or other problems beyond Lutron's control; or (h) direct exposure to corrosive materials.
2. On-site labor costs to diagnose issues with, and remove, repair, replace, adjust, reinstall and/or reprogram the System or any of its components.
3. Components and equipment external to the System, such as, non-Lutron lighting and automation systems; building wiring audio-visual equipment; and non-Lutron time clocks, photo-sensors and motion detectors.
4. The cost of repairing or replacing other property that is damaged when any System does not work properly, even if the damage was caused by the System.



**THIS WARRANTY IS IN LIEU OF ALL OTHER EXPRESS WARRANTIES. ALL IMPLIED WARRANTIES, INCLUDING THE IMPLIED WARRANTIES OF MERCHANTABILITY AND OF FITNESS FOR A PARTICULAR PURPOSE, ARE LIMITED TO EIGHT YEARS FROM THE DATE OF SHIPMENT, EXCEPT THAT SUCH IMPLIED WARRANTIES ARE LIMITED TO ONE YEAR FROM THE DATE OF SHIPMENT AS TO THE EXTERNAL SIVOIA QS COMPONENTS.**

**NO LUTRON AGENT, EMPLOYEE OR REPRESENTATIVE HAS ANY AUTHORITY TO BIND LUTRON TO ANY AFFIRMATION, REPRESENTATION OR WARRANTY CONCERNING THE SYSTEMS. UNLESS AN AFFIRMATION, REPRESENTATION OR WARRANTY MADE BY AN AGENT, EMPLOYEE OR REPRESENTATIVE IS SPECIFICALLY INCLUDED HEREIN, OR IN STANDARD PRINTED MATERIALS PROVIDED BY LUTRON, IT DOES NOT FORM A PART OF THE BASIS OF ANY BARGAIN BETWEEN LUTRON AND CUSTOMER AND WILL NOT IN ANY WAY BE ENFORCEABLE BY CUSTOMER.**

**IN NO EVENT WILL LUTRON OR ANY OTHER PARTY BE LIABLE FOR EXEMPLARY, CONSEQUENTIAL, INCIDENTAL OR SPECIAL DAMAGES (INCLUDING, BUT NOT LIMITED TO DAMAGES FOR PERSONAL INJURY, FAILURE TO MEET ANY DUTY, INCLUDING OF GOOD FAITH OR REASONABLE CARE, NEGLIGENCE, OR ANY OTHER LOSS WHATSOEVER), NOR FOR ANY REPAIR WORK UNDERTAKEN WITHOUT LUTRON'S PRIOR WRITTEN CONSENT ARISING OUT OF OR IN ANY WAY RELATED TO THE INSTALLATION, DEINSTALLATION, USE OF OR INABILITY TO USE THE SYSTEM OR OTHERWISE UNDER OR IN CONNECTION WITH ANY PROVISION OF THIS WARRANTY, EVEN IN THE EVENT OF THE FAULT, TORT (INCLUDING NEGLIGENCE), STRICT LIABILITY, BREACH OF CONTRACT OR BREACH OF WARRANTY OF LUTRON OR ANY OTHER PARTY, AND EVEN IF LUTRON OR SUCH OTHER PARTY WAS ADVISED OF THE POSSIBILITY OF SUCH DAMAGES.**

**NOTWITHSTANDING ANY DAMAGES THAT CUSTOMER MIGHT INCUR FOR ANY REASON WHATSOEVER (INCLUDING, WITHOUT LIMITATION, ALL DIRECT DAMAGES AND ALL DAMAGES LISTED ABOVE), THE ENTIRE LIABILITY OF LUTRON AND OF ALL OTHER PARTIES UNDER THIS WARRANTY ON ANY CLAIM FOR DAMAGES ARISING OUT OF OR IN CONNECTION WITH THE MANUFACTURE, SALE, INSTALLATION, DELIVERY, USE, REPAIR, OR REPLACEMENT OF THE SYSTEM, AND CUSTOMER'S SOLE REMEDY FOR THE FOREGOING, WILL BE LIMITED TO THE AMOUNT PAID BY CUSTOMER FOR THE SYSTEM. THE FOREGOING LIMITATIONS, EXCLUSIONS AND DISCLAIMERS WILL APPLY TO THE MAXIMUM EXTENT ALLOWED BY APPLICABLE LAW, EVEN IF ANY REMEDY FAILS ITS ESSENTIAL PURPOSE.**

**THIS WARRANTY GIVES YOU SPECIFIC LEGAL RIGHTS. YOU MAY ALSO HAVE OTHER RIGHTS WHICH VARY FROM STATE TO STATE. SOME STATES DO NOT ALLOW LIMITATIONS ON HOW LONG AN IMPLIED WARRANTY LASTS OR THE EXCLUSION OR LIMITATION OF INCIDENTAL OR CONSEQUENTIAL DAMAGES, SO THE ABOVE LIMITATIONS OR EXCLUSIONS MAY NOT APPLY TO YOU.**

#### **WARRANTY CLAIMS, TECHNICAL ASSISTANCE AND WARRANTY INFORMATION.**

Contact the Lutron Technical Support Center at the numbers provided below or your local Lutron sales representative with questions concerning the installation or operation of the System or this Warranty, or to make a warranty claim. Please provide the exact model number when calling.

The product may be covered under one or more of the following U.S. patents: 6,497,267; 6,983,783, 7,281,565; and corresponding foreign patents. U.S. and foreign patents pending.

Lutron, the Sunburst logo, Sivoia QED, and Sivoia are registered trademarks, and Sivoia QS is a trademark of Lutron Electronics Co., Inc.

# Technical Assistance

## **WORLD HEADQUARTERS**

Lutron Electronics Co., Inc.  
7200 Suter Road  
Coopersburg, PA 18036  
United States  
Tel: +1.610.282.3800  
Fax: +1.610-282.1243

## **ASIAN HEADQUARTERS**

Lutron GL Ltd.  
15 Hoe Chiang Road  
#07-03 Tower Fifteen  
Singapore 089316  
Tel: +65.6220.4666  
Fax: +65.6220.4333  
lutronsea@lutron.com

## **EUROPEAN HEADQUARTERS**

Lutron EA Ltd.  
6 Sovereign Close  
London, E1W 3JF  
United Kingdom  
Tel: +44.(0)20.7702.0657  
Fax: +44.(0)20.7480.6899

## **CUSTOMER SERVICE/ORDERING**

UK +44.(0)20.7702.0657  
09.00 - 18.00 GMT  
USA +1.610.282.3800  
08.00 - 20.00 EST

## **CUSTOMER SERVICE /E-MAIL**

shadinginfo@lutron.com

## **TECHNICAL SUPPORT & SERVICES**

USA +1.610.282.3800  
24 hours/7 days  
UK +44.(0)20.7702.0657  
09.00 - 18.00 GMT

## **INTERNET:**

www.lutron.com

## **ADDITIONAL LUTRON SALES OFFICES:**

### **Germany**

Tel: +49.309.710.4590  
Fax: +49.309.710.4591  
FREEPHONE  
00800-5887 6635

### **France**

Lutron Ltc, S.A.R.L.-Paris  
90 rue Villiers  
92300 Levallois Perret,  
France  
Tel: +33.1.41.05.42.80  
Fax: +33.1.41.05.01.80  
FREEPHONE: 0800.90.12.18  
lutronfrance@lutron.com

### **Spain-Madrid**

Tel: +34.91.567.84.79  
Fax: +34.91.567.84.78  
FREEPHONE 0900.948.944

### **Spain-Barcelona**

Tel: +34.93.496.57.42  
Fax: +34.93.496.57.50  
FREEPHONE 0900.948.944

### **Hong Kong**

Tel: +852.2104.7733  
Fax: +852.2104.7633

### **Beijing**

Tel: +86.10.5877.1817  
Fax: +86.10.5877.1816

### **Singapore**

LUTRON GL Ltd.  
Singapore  
15 Hoe Chiang Road  
#7-03 Tower 15  
Singapore 089316  
Tel: +65.6220.4666  
Fax: +65.6220.4333

### **Japan**

Tel: +81.3.5575.8411  
Fax: +81.3.5575.8420

[www.lutron.com/shadingsolutions](http://www.lutron.com/shadingsolutions)

USA and Canada (24 hrs/7days):  
call: 800.523.9466

Other countries (8 a.m. – 8 p.m. ET)  
call: +1.610.282.3800  
fax: +1.610.282.3090

email: [shadinginfo@lutron.com](mailto:shadinginfo@lutron.com)

©2007 LUTRON Electronics Co., Inc.

Printed in the U.S.A.  
P/N 045-1408 Rev. B

