

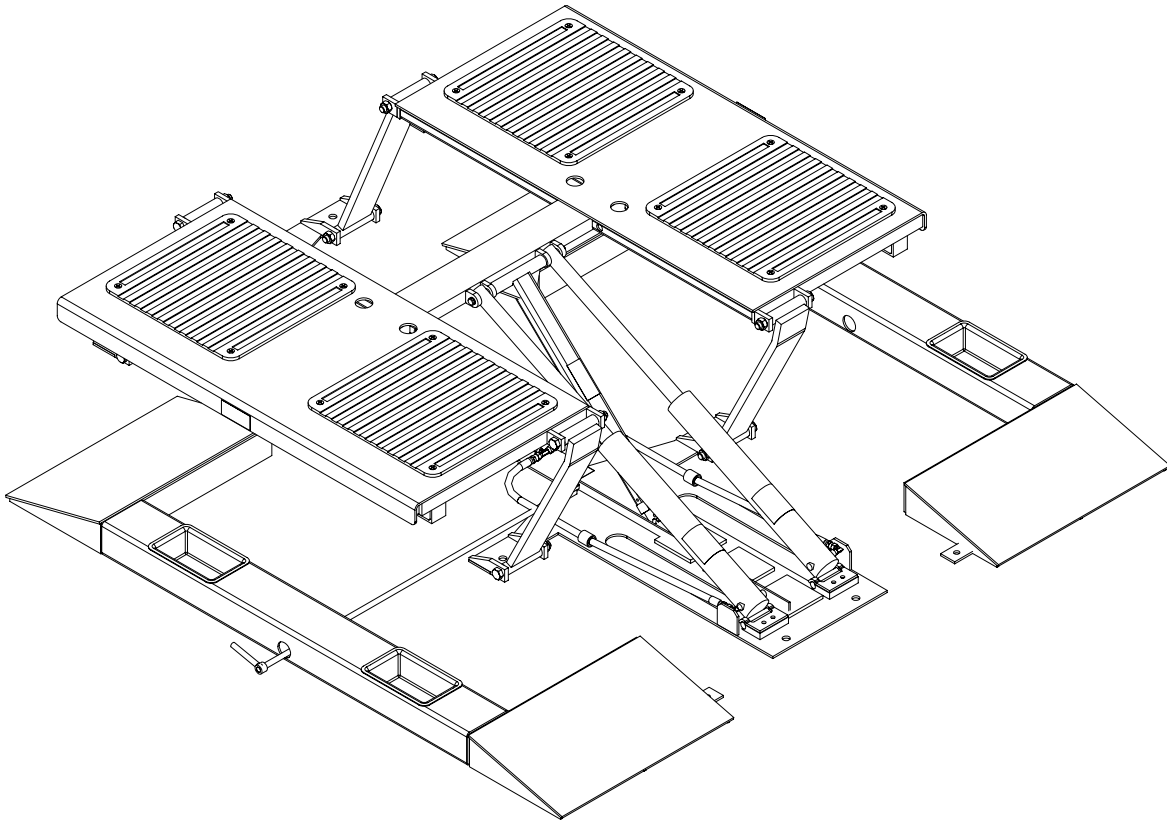

Multi-Purpose
Surface Mounted Lift



Model ACL10PR-F

Hennessy Industries, Inc., 1601 J.P. Hennessy Drive, LaVergne, TN 37086-3565
Email: liftservice@ammcoats.com & liftsales@ammcoats.com Web: www.ammcoats.com
Office 888-760-LIFT (5438)

**IMPORTANT: READ THIS MANUAL COMPLETELY BEFORE
INSTALLING or OPERATING LIFT**

General Specifications

Maximum Capacity	10000 U.S. Pounds
Lowered Height.....	4 1/4 inches
Raised Height	22 inches
Locking Bar Height.....	13 3/4", 18 3/8", 21 1/4"
Overall Width	85 inches
Overall Length	90 9/16 inches
Rearward Movement.....	13 1/4 inches
Motor.....	1 Hp, 115 Volt, 1 phase, 60 Hz

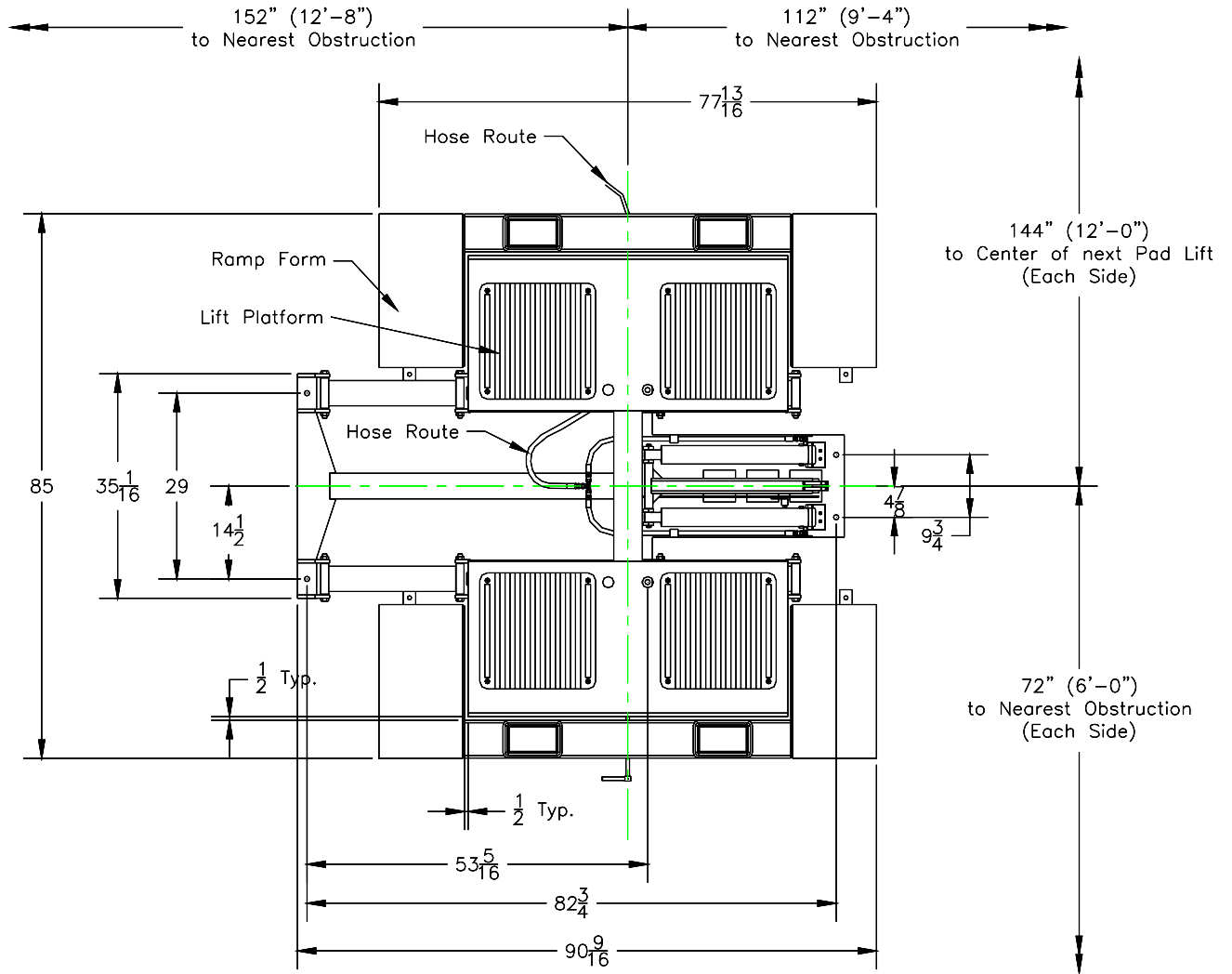

Fig. 1 General Layout

Model ACL10PR-F Installation, Operation & Maintenance

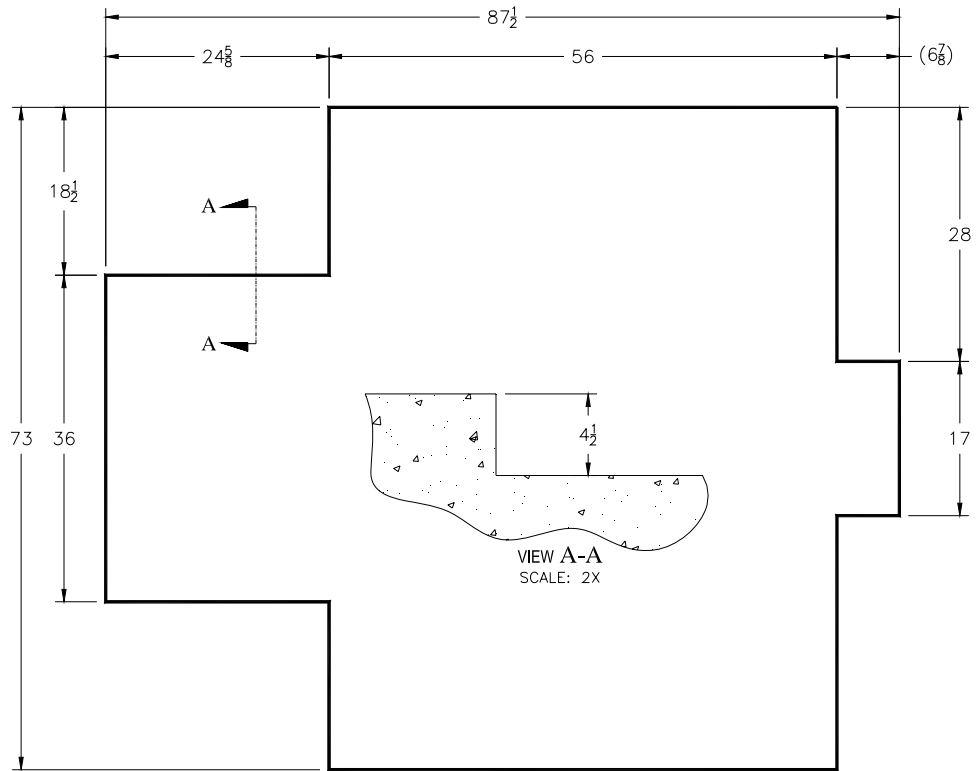

Fig. 2 – CONCRETE LAYOUT

BEFORE YOU BEGIN

Safety Notices and Decals

For your safety, and the safety of others, read and understand all of the safety notices and decals included here.

READ ENTIRE MANUAL BEFORE ASSEMBLING, INSTALLING, OPERATING, OR SERVICING THIS EQUIPMENT.

PROPER MAINTENANCE AND INSPECTION IS NECESSARY FOR SAFE OPERATION.

DO NOT operate a damaged lift.

Safety decals similar to those shown here are found on a properly installed lift. Be sure that all safety decals have been correctly installed on the lift. Verify that all authorized operators know the location of these decals and fully understand their meaning. Replace worn, faded, or damaged decals promptly.

⚠ WARNING Do not attempt to raise a vehicle on the lift until the lift has been correctly installed and adjusted as described in this manual.

LOCATION

This lift has been evaluated for indoor use only with an operating ambient temp. range of 5 – 40°C (41– 104°F)

SAFETY INSTRUCTIONS

If attachments, accessories or configuration modifying components that are located in the load path, affect operation of the lift, affect the lift electrical listing or affect intended vehicle accommodation are used on this lift and, if they are not certified for use on this lift, then the certification of this lift shall become null and void. Contact the participant for information pertaining to certified attachments, accessories or configuration modifying components.

www.autolift.org ©2007 by ALI, Inc. ALI / WLSIAO1

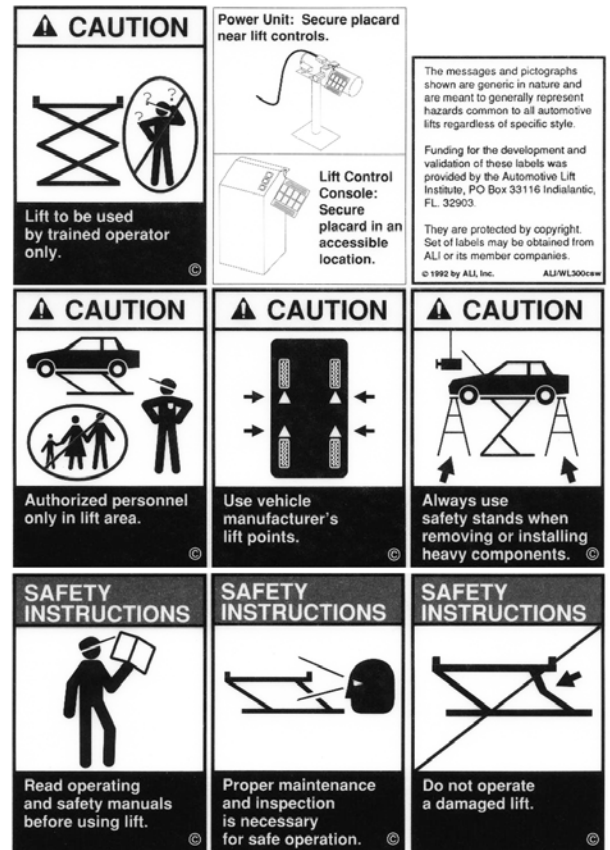

SAFETY WARNING LABELS FOR HINGED FRAME ENGAGING LIFTS
Lift Owner/User Responsibilities:

- A. This Safety Warning placard SHALL be displayed in a conspicuous location in the lift area.
- B. Use one of the mounting arrangements illustrated on back of this placard.
- C. These Safety Warning labels supplement other documents supplied with the lift.
- D. Be certain all lift operators read and understand these labels, operating instructions and other safety related information supplied with the lift.



RECEIVING

The shipment should be thoroughly inspected as soon as it is received. The signed bill of lading is acknowledgement by the carrier of receipt in good condition of shipment covered by our invoice.

If any of the goods called for on this bill of lading are shorted or damaged, do not accept them until the carrier makes a notation on the freight bill of the shorted or damaged goods. Do this for your own protection.

NOTIFY **Ammco-Lifts** AT ONCE if any hidden loss or damage is discovered after receipt

IT IS DIFFICULT TO COLLECT FOR LOSS OR DAMAGE AFTER YOU HAVE GIVEN THE CARRIER A CLEAR RECEIPT.

File your claim with **Ammco-Lifts** promptly. Support your claim with copies of the bill of lading, freight bill, and photographs, if available.

Flooring

Be certain you have the proper concrete floor to properly handle the loaded lift. Floor should be in generally good condition with no large cracks, spalling or deterioration. Minimum requirements for concrete are 4 inches minimum depth, with steel reinforcement per local commercial practice, 3500 psi, cured for 28 days. Floor should be level within 1/4 inch over the installation area. No anchors should be installed within 8 inches of any crack, edge, or expansion joint. If these conditions cannot be met, pads can be poured to accommodate the lift. Pad must be minimum of 8 ft x 8 ft x 1 ft minimum thickness, 3500 psi steel reinforced mechanically attached to existing floor.



WARNING Failure by purchaser to provide the recommended mounting surface could result in unsatisfactory lift performance, property damage, or personal injury.

Vertical Clearance

Check the height of the area where the lift is to be installed. Clearance should be calculated based on the full raised height of the lift plus the height of the tallest vehicle you intend to service.



WARNING Failure by purchaser to provide adequate clearance could result in unsatisfactory lift performance, property damage, or personal injury.

ELECTRICAL REQUIREMENTS

For lift installation and operation, it is necessary to have a dedicated 115V single-phase 60-cycle circuit with a 20 amp circuit breaker or time delay fuse.

Tools Required for Installation

1. Concrete hammer drill.
2. 3/4 inch & 1/2 inch solid drill bit with carbide tip to ANSI Standard B94.12-1977.
3. Wrenches: 7/16, 1/2, 9/16, 5/8, 11/16, 15/16, 1 1/8 inch
4. Ratchet drive with the following sockets: 7/16, 1/2, 9/16, 1 1/8 inch
5. Hammer
6. Funnel
7. Torque wrench: 150 to 250 foot pounds
8. Adjustable wrenches: 8 and 12 inch

General Anchor Bolt Instructions

1. The anchor bolts must be installed at least 8 inches from any crack, edge, or expansion joint.
2. Use a concrete hammer drill with a 3/4-inch carbide tip. Tip diameter to ANSI Standard B94.12-1977 (.775 to .787).
3. Do not use excessively worn bits or bits which have been incorrectly sharpened.
4. Keep the drill in a perpendicular line while drilling.
5. Let the drill do the work. Do not apply excessive pressure.
6. Lift the drill up and down to remove dust and reduce binding.
7. Drill the hole through the floor or to a depth of 5 inches minimum. Drill completely through floor if possible.
8. Vacuum the dust from the hole. This increases the holding power of the anchor bolts.
9. Insert the assembled anchor bolt into the hole.
10. Tighten the bolt securely, and torque to 150 foot-pounds after installation is complete.

NOTE: Anchor bolt holes are designed for a tight fit. Using the lift frame, as a template will slightly enlarge the holes, allowing for proper tolerances once the anchor bolt is installed.

Installation

1. Locate the pad lift on a level concrete floor with adequate space on all sides as shown in Fig. 1. Minimum floor thickness is 4". Minimum floor strength is 3500 psi.

WARNING DO NOT install on asphalt or other similar unstable surface.

NOTE:
The pad lift can be installed with the cylinder end pointing towards the front or rear of bay. **Be aware of pad lift clearances according to installation option chosen.**

NOTE:
At full rise, the lift will move the vehicle **rearward** 13 1/4" as shown in Fig. 3.

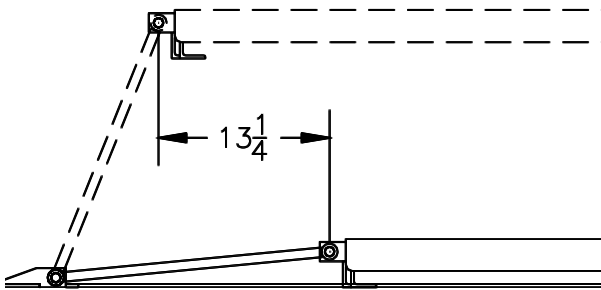

Fig. 3 Rearward Movement

2. Anchoring the lift, there are (6) 13/16" diameter holes provided in the base frame and (8) 5/8" diameter holes in the ramp forms. The holes are sized for 3/4" and 1/2" anchor bolts. Use the holes as a template when drilling into floor. The ramp form should be located to allow a minimum 1/2" clearance around the lift platform, See Fig.1.

NOTE:
The pad lift frame must not be twisted, bent or otherwise misaligned by uneven floors when anchoring. This will cause damage to the lift. Maximum out-of-level is 1/4" between all anchor points. If this is exceeded, it must be shimmed at that anchor point.

CAUTION If lift is to be used in a paint booth, the electrical power unit **MUST** be mounted outside the booth.

Power Unit

1. Locate the power unit stand using concrete anchors provided. Mount the power unit to the stand with 5/16" hardware provided. (The power unit may also be mounted on a wall with the motor at a minimum of 18" above the floor. Purchase the appropriate mounting hardware to match the wall construction.)
2. Connect the end of the hydraulic hose with the 90-degree elbow to the pressure port on the power unit. Tighten securely to prevent leaking.

NOTE: To avoid damage to the hose, never run the hose under the lift or in the path of the automobile tires.

3. Fill the reservoir with 6 quarts clean 10wt anti-foam, anti-rust hydraulic oil or Dexron III ATF. **DO NOT USE OILS WITH DETERGENTS.**
4. Place the open end of the hose into a clean bucket.
5. Plug power unit cord into a dedicated 115V single phase 60 cycle circuit with a 25 amp circuit breaker or time delay fuse
6. Cycle the power unit (2 seconds on, 2 seconds off) until the hose expels a steady stream of fluid.
7. Connect the hose to the tee fitting on the lift.
8. Actuate the power unit and raise the lift fully, then lower the lift to the floor. Repeat 3 to 4 times.
9. Drill the anchor holes and install the lift anchor bolts.

CAUTION The power unit operates at high pressure.

Raise and lower lift a few times and check hose and fittings for leaks and tighten if required.

Check for binding, misalignment or damage. Correct any unusual condition before raising vehicle.

Owner/Operator Checklist

SAVE THESE INSTRUCTIONS deliver them to owner/user/employee along with other materials furnished with this lift.

- Demonstrate the operation of the lift to the owner/operator and review correct and safe lifting procedures using the **Lifting It Right** booklet as a guide.
- Complete the Installation Checklist/Warranty Validation questionnaire with the owner. Review the terms of the warranty registration card, and return the card and a copy of the questionnaires to:

Hennessy Industries, Inc.

1601 J.P. Hennessy Drive

LaVergne, TN 37086-3565

Safety Notices and Decals

This product is furnished with graphic safety warning labels, which are reproduced on page 3 of these instructions. Do not remove or deface these warning labels, or allow them to be removed or defaced. For your safety, and the safety of others, read and understand all of the safety notices and decals included.

Owner/Employer Responsibilities

This lift has been designed and constructed according to ANSI/ALI ALCTV-2006 standard. The standard applies to lift manufacturers, as well as to owners and employers. The owner/employer's responsibilities as prescribed by ANSI/ALI ALOIM-2000, are summarized below. For exact wording refer to the actual standard provided with this manual in the literature pack.

The Owner/Employer shall insure that the lift operators are qualified and that they are trained in the safe use and operation of the lift using the manufacturer's operating instructions; ALI/SM 93-1, ALI Lifting It Right Safety Manual; ALI/ST-90 ALI Safety Tips Card; ANSI/ALI ALOIM-2000; American National Standard for Automotive Lifts-Safety Requirements for Operation, Inspection and Maintenance; ALI/WL Series, ALI Uniform Warning Label Decals/Placards; and in case of frame engaging lifts, ALI/LP-GUIDE, Vehicle Lifting Points/Quick Reference Guide for Frame Engaging Lifts.

The Owner/Employer shall establish procedures to periodically inspect the lift in accordance with the lift manufacturer's instructions or ANSI/ALOIM-2000, American

National Standard for Automotive Lifts-Safety Requirements for Operation, Inspection and Maintenance; and the employer shall insure that the lift inspectors are qualified and they are adequately trained in the inspection of the lift.

The Owner/Employer shall establish procedures to periodically maintain the lift in accordance with the lift manufacturer's instructions or ANSI/ALOIM-2000, American National Standard for Automotive Lifts-Safety Requirements for Operation, Inspection and Maintenance; and the employer shall insure that the lift maintenance personnel are qualified and they are adequately trained in the inspection of the lift.

The Owner/Employer shall maintain the periodic inspection and maintenance records recommended by the lift manufacturer or ANSI/ALOIM-2000, American National Standard for Automotive Lifts-Safety Requirements for Operation, Inspection and Maintenance.

The Owner/Employer shall display the lift manufacturer's operating instructions; ALI/SM 93-1, ALI Lifting It Right Safety Manual; ALI/ST-90 ALI Safety Tips Card; ANSI/ALI ALOIM-2000; American National Standard for Automotive Lifts-Safety Requirements for Operation, Inspection and Maintenance; and in case of frame engaging lift, ALI/LP-GUIDE, Vehicle Lifting Points/Quick Reference Guide for Frame Engaging Lifts; in a conspicuous location in the lift area convenient to the operator.

IMPORTANT SAFETY INSTRUCTIONS

When using your garage equipment, basic safety precautions should always be followed, including the following:

1. Read all instructions.
2. Care must be taken as burns can occur from touching hot parts.
3. To reduce the risk of fire, do not operate equipment in the vicinity of open containers of flammable liquids (gasoline).
4. Keep hair, loose clothing, fingers, and all parts of body away from moving parts.
5. Use only as described in this manual. Use only manufacturer's recommended attachments.
6. ALWAYS WEAR SAFETY GLASSES. Everyday eyeglasses only have impact resistant lenses, they are not safety glasses.

SAVE THESE INSTRUCTIONS

Operating Instructions

NOTE:

After reviewing these instructions and all decals, get familiar with lift controls by running the lift through a few cycles before loading vehicle on lift.

Loading Vehicle

1. Be sure lift is fully lowered and service bay is clear of all personnel before the vehicle is driven on to lift.
2. Position vehicle over lift having equal distance from front tire to end of front ramps and rear tire to end of rear ramps. Vehicle must also be centered side to side.



WARNING Lift is designed to raise complete vehicle. **NEVER** use to raise just one end or Side of vehicle.

NOTE:

Some vehicles may have the manufacturer's recommended lift points identified by triangle shape marks located on its undercarriage. Also, there may be a label located on the right front door lock face showing specific vehicle lift points. If the vehicles lift points are not identified, refer to the service garage lift points shown in Fig. 4. **ALWAYS** follow the operating instructions supplied with the lift.

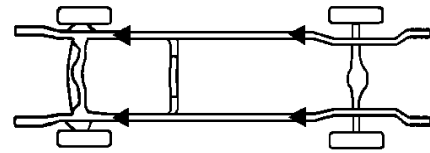

Ladder

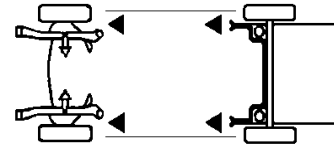

Unitized

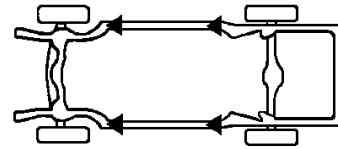

Perimeter

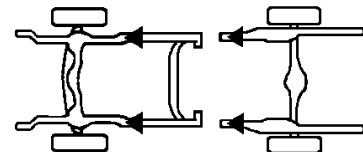

Stub

Fig 4 Service Garage Lift Points

⚠ CAUTION Most specialty or modified vehicles cannot be raised on a frame engaging or pad lift. Contact vehicle manufacturer for raising or jacking details.

3. Before lifting the vehicle be sure that:
 - A. Individual axle weight of vehicle does not exceed one-half lift capacity. See safety instructions (capacity).
 - B. Spacer pads are in secure contact with frame at vehicle manufacturer's recommended lift points.
 - C. Vehicle is stable on lift and neither front nor rear heavy.
 - D. Use optional 4 3/4" and 6 3/4" spacer pads if additional height between lift and vehicle is required to clear underbody parts as shown in Fig. 5.

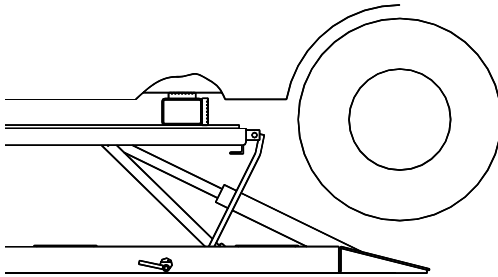

Fig 5 Optional Spacer Pads

⚠ CAUTION Always use minimum number of spacer pads to clear obstruction. Spacer pads should never be stacked more than (2) pads high in any combination.

⚠ CAUTION With some vehicles, the removal (or installation) of heavy components may cause a critical shift in balance and result in vehicle instability. Refer to the vehicle manufacturer's service manual for recommended procedures when performing these services.

Raising Vehicle

4. To raise lift (SR10, SRM10 & SRF10):
 - A. Actuate **RAISE** switch on electric power unit.
 - B. Raise vehicle until tires clear floor.
 - C. Stop and check spacer pads for secure contact at manufacturer's recommended lift points.
 - D. Continue to raise to desired height **ONLY** if vehicle is secure on lift.
 - E. Once you have reached the required height set into lock by depressing the lowering handle.

Lowering Vehicle

5. To lower lift (SR10 & SRF10):

Stand clear of lift and vehicle when lowering. Observe pinch point warning decals.

 - A. Remove all tools or other objects from lift area.
 - B. Raise vehicle approximately 1" to disengage lock.
 - C. Push **LOWERING** valve handle to lower lift.
6. To lower lift (SRM10):

Stand clear of lift and vehicle when lowering. Observe pinch point warning decals.

 - A. Remove all tools or other objects from lift area.
 - B. Raise vehicle approximately 1".
 - C. Disengage lock by rotating the lock release handle clockwise until it stops.
 - D. Push **LOWERING** valve handle to lower lift.

⚠ CAUTION Lowering handle must be held down to continue to lower lift. **DO NOT** override self-closing lift controls.

7. Before moving vehicle, remove any spacer pads and be sure lift is at the fully lowered position.

NOTE:

The lock bar will reset automatically when the lift is fully lowered or raised a minimum of 1". If during the lowering process the lift is stopped before it gets to the fully lowered position. Reset by repeating steps 5 or 6 from above.

MAINTENANCE

To avoid personal injury, permit only qualified personnel to perform maintenance on this equipment. Maintenance personnel should follow lockout/tagout instructions per ANSI Z244.1.

The following maintenance points are suggested as the basis of a routine maintenance program. The actual maintenance program should be tailored to the installation. See ANSI/ALI ALOIM booklet for periodic inspection checklist and maintenance log sheet.

- If lift stops short of full rise or chatters, check fluid level and bleed both cylinders per Installation Instructions.
- Replace all Safety, Warning or Caution Labels if missing or damaged (**See *Installation instructions page 3.***)

See repair parts breakdown for replacement parts.

ALWAYS: Keep all anchor bolts tight. (1/2" Anchors 60 ft-lbs, 3/4" Anchors 80 ft-lbs).

ALWAYS: Keep all pivot bolts tight.

ALWAYS: Keep lift clean. Raise lift when cleaning floor area.

DAILY: Inspect spacer pads for damage or excessive wear.

DAILY: Check lock bar handle and release mechanism for damage or binding.

WEEKLY: Inspect all lift parts for signs of damage due to improper use.

MONTHLY: Lubricate lock bar pivot bolt and lock bar handle pivot points.

MONTHLY: Lubricate all hinge joints if there are signs of rusting.

MONTHLY: Visually inspect concrete floor for cracks and/or spalls within 12" of base plate

SEMI-ANNUALLY: Check fluid level of lift power unit and refill if required. Use only Dexron III ATF or 10wt anti-foam, anti-rust hydraulic oil. If fluid is required, inspect hose and connections and cylinder seals. Repair as required.