

- ※1 : Load rating at counterclockwise : Max. wire rope tension is 3,920N (400kgf). Gear ratio is 1/4. Quick Winding Handle is unable to use for lowering.
- ※To prevent irregular winding of the wire rope around the drum, keep the fleet angle 2 degrees or less. Please install the pulley 2670mm or more away from the drum on the center line of the drum.
- ※The value of specified "Wire Rope Tension" on this drawing is for the standard layer or less. The value of the "Wire Rope Tension" must be decreased accordance with the ratio of the actual winding layers, if it exceeded.

Specifications				(The wire rope composition is a manufacturer recommendation.)	
Load Rating Wire Rope Tension	19,600N (=2,000kgf) 3rd Layer (Standard Layer)	Handle Force	Handle Length 370mm Wire Rope Tension 19,600N	Number of Wire Rope Winding Layer 1st Layer 157N (=16.0kgf) 2nd Layer 186N (=18.9kgf) 3rd Layer 214N (=21.8kgf)	
Drum Capacity	Wire Rope 5-Layer Windings φ 9mm (6 × 37), JIS × 38m	Standard Accessories		One Flat Handle, One Box Handle	
Gear Ratio	Normal : 1/20,※1 Quick : 1/4	Painting		One Hex Wrench for Anchoring the Wire Rope	
Effective Handle Length	370mm (Maximum)				
Weight	28.2kg (Winch + Handle)				

Special Specifications
○The parts for hot dip galvanizing are : gear case, gear case cover, drum, side frame, bed plate, clutch cover and handle arm.
○The stay bolt, bolts, screws, nuts, retaining ring and spring are made of SUS-304.
○Chromate plating is applied to the stopper, clutch and handle holder and then Roval Silver is painted over it.
○The shaft is chromate plated and only the tip of the shaft is painted with Roval Silver.

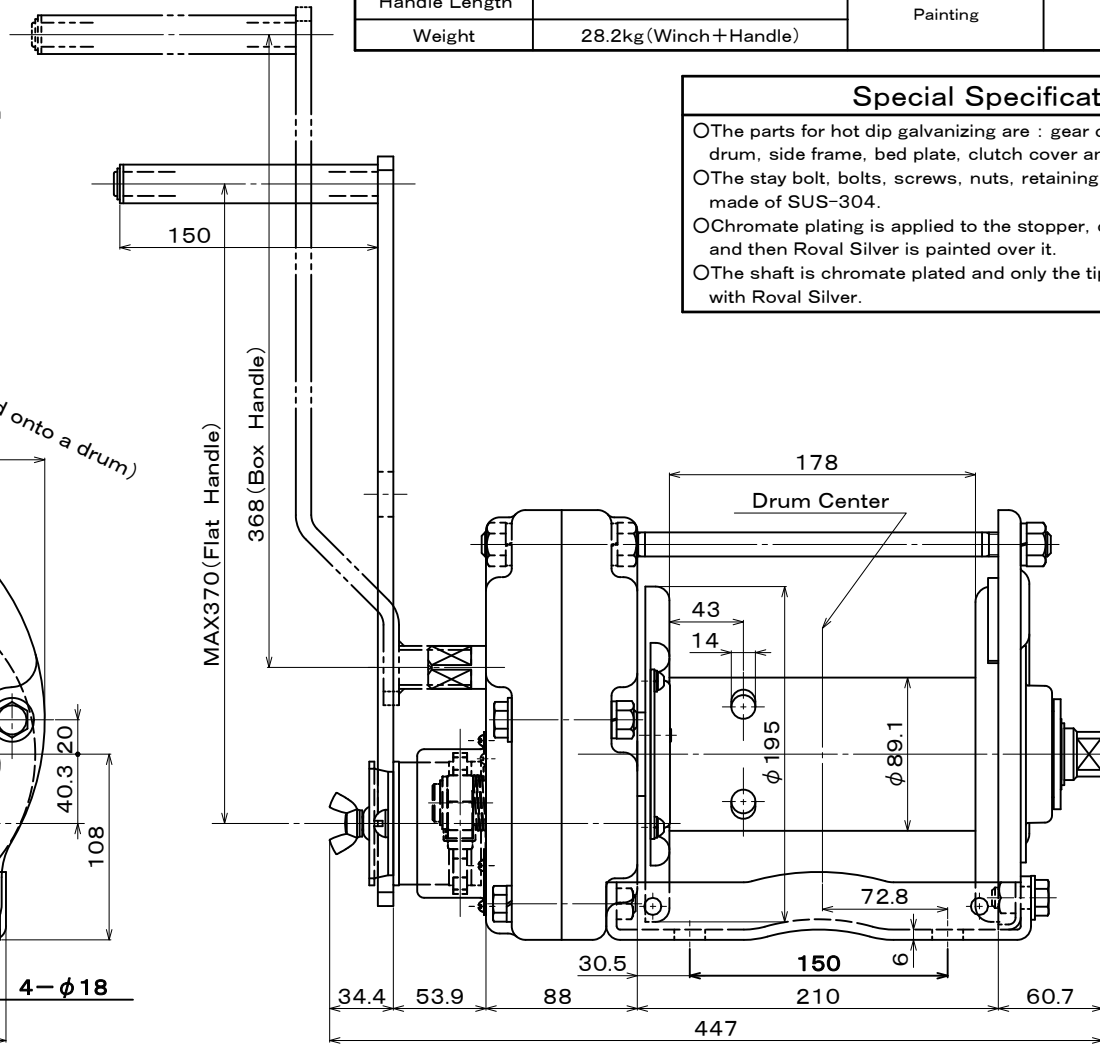
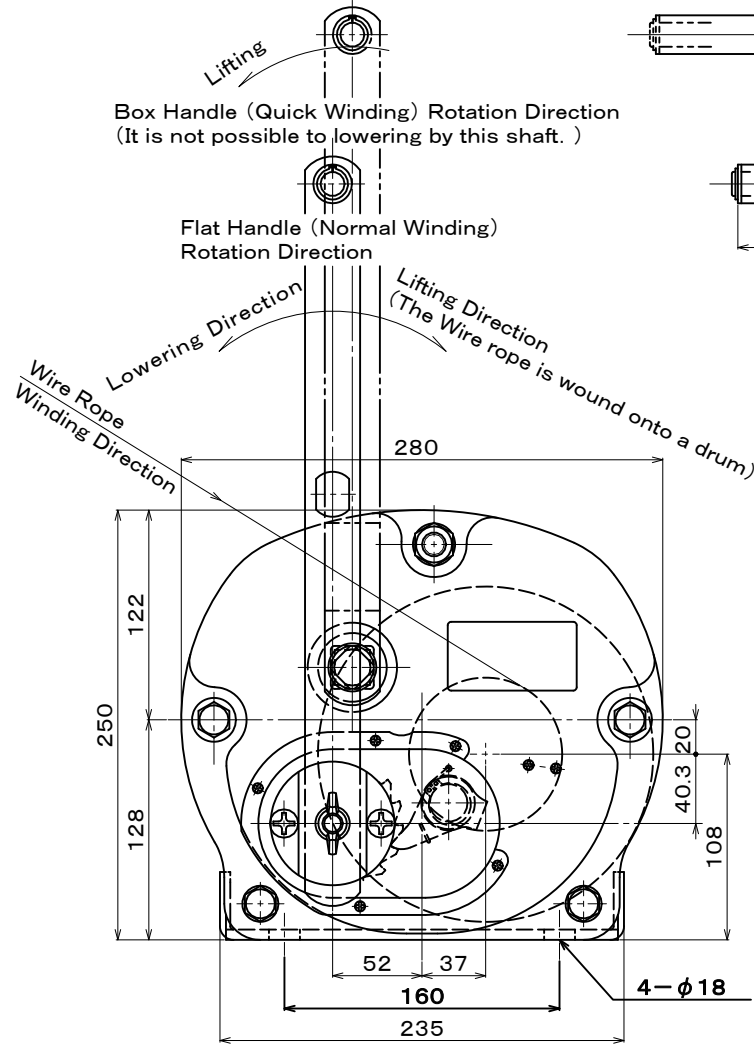

△ ×			図面番号 / DRAWING No. GM20GSSI-160729-01E	改訂番号 / REVISION No. 00	お客様 / CUSTOMER	符号 MARK	項目 PARTICULARS	材料 MATERIAL	数量 QTY	単体合計 PER ONE TOTAL 重量(kg) WEIGHT	備考 REMARKS
△ ×			承認 / APPROVED	検図 / CHECKED	作成 / DRAWN	図面名 / TITLE MAXPULL WINCH CORROSION RESISTANT AND SALT RESISTANT (HOT DIP GALVANIZING) STOPPER ARMLESS ROTATING MODEL GM-20-GS-SI		投影法 / PROJECTION METHOD 第三角法 THIRD ANGLE PROJECTION		尺度 / SCALE 台数 / QTY	
△ ×			設計部 '16.08.01 米澤	設計部 '16.08.01 松嶺	設計部 '16.07.29 武松	MAXPULL MACHINERY & ENGINEERING CO. LTD. マックスプル工業株式会社					
△ ×											
改訂 / REVISION											