



**WESCO**

**Rubbermaid**  
Commercial Products

**KLETON**

**DC**  
**StrongHold**

**METALWARE**  
STEEL SHELVING  
corporation

**LISTA**  
making workspace work®



# MATERIAL HANDLING & STORAGE



Containers.....	4 - 17
Small Parts & Bulk Storage .....	18 - 45
Pallets .....	46 - 48
Racking & Shelving.....	49 - 78
Barriers, Partitions & Portable Structures .....	79 - 93
Storage Cabinets & Lockers .....	94 - 110
Workbenches & Cabinets .....	112 - 126
Ladders, Stools & Scaffolding.....	127 - 143
Hand Trucks & Platform Trucks .....	144 - 157
Utility Carts, Specialized Carts & Tricycles .....	158 - 170
Hoppers, Tilt Trucks, Box Trucks & Dollies .....	171 - 177
Lift Tables, Stackers, Pallet Trucks & Accessories.....	178 - 187
Lifting and Positioning Equipment.....	188 - 205
Automotive Equipment & Wheel Chocks.....	206 - 211
Dock Equipment & Cable Protectors .....	212 - 217
Dock Lighting & Warning Systems.....	218 - 223
Conveyors.....	224 - 225
Casters & Wheels .....	226 - 233
Drums & Drum Equipment .....	234 - 253
Pumps.....	254 - 264

**FEATHERLITE**  
INDUSTRIAL LADDERS

**ASM**

**TECHSTAR**  
PLASTICS INC.

**MORSE**

**DURHAM MFG**  
Est. 1922

**Vestil**  
We've Got It!

# BINS/SUPPORT RACKS & CABINETS

## HI-STAK PLASTIC BINS

- Innovative stacking design allows for greater visibility and easier access to contents
- Distortion-free from -40°C to 120°C
- Unaffected by oil, alkaline and most acids
- Ideal in production or for store display
- Included with each bin: I.D. card with clear plastic shield, four riser legs and connector clip



Inclined faceplate with removable label and protector



1" riser legs increase loading capacity and stability



Stackable using built-in feet



Connector clip allows for back-to-back mounting

Built-in extrusions allow side-by-side interlock

Model No.				Outside Dimensions			Wt. lbs.	Price /Each	Faceplate & Label Model No.	Price /Each	Replacement Legs Model No.	Price /Package
Blue	Yellow	Green	Red	W"	x D"	x H"						
CB260	CB261	CC234	CC242	4 13/16	x 7 1/8	x 3 3/16	0.10	2.15	CC441	0.35	CC263	0.65
CB262	CB263	CC235	CC243	5 7/8	x 9 13/16	x 4 11/16	0.15	4.25	CC441	0.35	CC263	0.65
CB264	CB265	CC236	CC244	8 3/16	x 14	x 6 3/16	0.35	8.65	CC443	0.70	CC437	1.00
CC239	CC240	CC237	CC245	7 7/8	x 17 11/16	x 7	0.55	12.25	CC443	0.70	CC437	1.00
CB266	CB267	CC238	CC246	11 13/16	x 17 11/16	x 7	0.60	17.50	CC443	0.70	CC437	1.00

Note: Add 1 inch to overall height when stacking on legs.

## WIRE MESH STACK & HANG BINS

- Innovative mesh design offers nickel-chrome finish and a 3/8" x 3/8" grid pattern allowing complete visibility of bin contents
- This unique mesh pattern provides a dust and dirt free storage environment
- Mesh Bins feature a rear hanger that allows them to hang from any louvered wall panel or rail system
- Optional side hangers allow bin to stack one on top of the other
- The open hopper design allows for easy picking while allowing visual access to stored contents
- Material: Wire mesh
- Colour: Nickel-chrome
- Capacity: 100 lbs. Hang/175 lbs. Stack

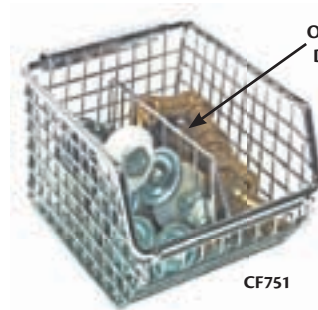

Optional Divider

CF751



CF755



### BINS

Model No.	Mfg. No.	Outside Dimensions				Inside Dimensions				Price /Each	DIVIDERS		Price /Each
		W"	x D"	x H"	W"	x D"	x H"	Model No.	Mfg. No.				
CF751	QMB510C	4 1/4	x 5 1/4	x 3	4	x 4 3/4	x 2 7/8	16.40	CF766	DMB510C	8.15		
CF752	QMB520C	4 1/4	x 7 1/4	x 3	4	x 6 3/4	x 2 7/8	18.70	CF767	DMB520C	9.55		
CF753	QMB530C	5 1/2	x 10 3/4	x 5	5 1/2	x 10 1/4	x 4 3/4	23.80	CF768	DMB530/535C	13.70		
CF754	QMB535C	11	x 10 3/4	x 5	10 3/4	x 10 1/4	x 4 3/4	34.40	CF768	DMB530/535C	13.70		
CF755	QMB539C	8	x 10 1/2	x 7	7 1/2	x 10	x 6 3/4	27.80	CF769	DMB539C	14.10		
CF756	QMB540C	8	x 14 1/2	x 7	7 2/5	x 14	x 6 3/4	37.60	CF770	DMB540/550C	16.60		
CF757	QMB550C	16 1/4	x 14 1/2	x 7	15 3/4	x 14	x 6 3/4	50.60	CF770	DMB540/550C	16.60		
CF758	QMB560C	11	x 18 1/2	x 10 1/8	10 5/8	x 18 1/16	x 10	68.70	CF771	DMB560/570C	23.50		
CF759	QMB570C	17 1/8	x 18 1/2	x 11 1/8	16 5/8	x 18 1/8	x 11	81.50	CF771	DMB560/570C	23.50		

### SIDE HANGERS\*

Model No.	Mfg. No.	Description	Price /Each
CF760	HMB510C	For Bin CF751	4.70
CF761	HMB520C	For Bin CF752	4.90
CF762	HMB530/535C	For Bin CF753/CF754	5.40
CF763	HMB539C	For Bin CF755	5.80
CF764	HMB540/550C	For Bin CF756/CF757	5.50
CF765	HMB560/570C	For Bin CF758/CF759	6.50

\*Hangers sold per pair



Optional Side Hangers



# BINS/SUPPORT RACKS & CABINETS

## PLASTIC BINS

- Designed to hang from bin racks, panels, rails and carts
- Bins reduce and control inventories, shorten assembly times and minimize parts handling
- Reinforced ribs, on both sides, prevent bins from spreading under loads
- Unaffected by weak acids and alkalis
- Stackable
- 6 available colours allow for colour coding

KLETON

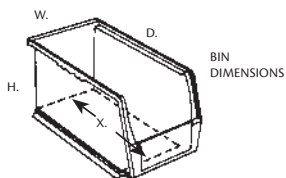
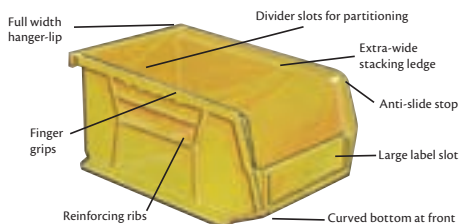

**MIX & MATCH**

Need racks to hold these bins?  
See pages 7-9

Need a cabinet to hold these bins?  
See page 10

Bin Model No.						Mfg. No.	Outside Dimensions			Bin Load Cap. lbs.	Price /Each	Model No.	Price /Each
Blue	Red	Yellow	Green	Stone	Clear		W"	x	D"				
CB093	CB094	CB095	CB663	CB664	CF427	30-210	4 1/8	x	5 3/8	x	3	CB124	0.30
CB096	CB097	CB098	CB665	CB666	CF428	30-220	4 1/8	x	7 3/8	x	3	CB125	0.30
CB099	CB100	CB101	CB667	CB668	CF429	30-230	5 1/2	x	10 7/8	x	5	CD513	0.54
CB102	CB103	CB104	CB669	CB670	CF430	30-235	11	x	10 7/8	x	5	CD514	0.54
CB105	CB106	CB107	CB671	CB672	CF431	30-239	8 1/4	x	10 3/4	x	7	CB128	0.61
CB108	CB109	CB110	CB673	CB674	CF432	30-240	8 1/4	x	14 3/4	x	7	CB129	0.77
CB111	CB112	CB113	CB675	CB676	CF433	30-250	16 1/2	x	14 3/4	x	7	CF023	0.82

## BIN BUDDY™ & TRI-DEX™ LABEL HOLDERS

- Clear self-adhesive backing adheres to any plastic or metal container
- Clear bar code compatible window protects label from dirt and moisture
- Tri-Dex™ label holders snap into bin slots protecting label or barcode
- Includes a set of laser/ink jet compatible labels, 25/pack
- Extra refill labels are also available, sold 50 sheets/pack

Priced per Pack

Model No.	Mfg. No.	Dimensions"	Description	Price /Each	Refill Labels	Description	Price /Each
OF212	BB-13	1 x 3	Bin Buddy™, Top/Bottom load, Self Adhesive	24.80	OF216	20 labels/sheet	30.80
OF210	BB-35	3 x 5	Bin Buddy™, Side Load, Self Adhesive	29.95	OF214	4 labels/sheet	30.80
OK113	TR-0813	13/16 x 3	Tri-Dex™, Ideal for Shelf Bins	19.50	OK118	24 labels/sheet	30.80
OK114	TR-1300	1 x 3	Tri-Dex™, Ideal for Bin Series 30-210,30-220	20.30	OK119	20 labels/sheet	30.80
OK116	TR-1754	1 3/4 x 4	Tri-Dex™, Ideal for Bin Series 30-230,30-250	24.80	OK121	12 labels/sheet	30.80



OK113

Bin not included



OF212

## 1800 SERIES AKRO-BINS

- Extra large and strong for heavier, bulkier parts and components
- Designed to fit standard 18" deep shelving
- Reinforced ribs prevent spreading under big loads
- Front and back finger grips make handling easy
- One black cross-wise divider per bin is provided
- Stackable
- Light beige



Model No.	Mfg. No.	Outside Dimensions W" x D" x H"	Wt. lbs.	Price /Each	Dividers Model No.	Price /Each
CB122	30-348	8 1/4 x 20 1/2 x 7	3.5	33.90	CB134	4.99
CB123	30-358	11 x 20 1/2 x 7	4.0	36.80	CB135	5.63

## RECYCLED PLASTIC BINS

- Manufactured from recycled 100% post consumer, high density polyethylene
- Available in black only



ip  
INTEGRATED PLASTICS



Model No.	Mfg. No.	Outside Dimensions W" x D" x H"	Price /Each	Dividers	Price /Each
CF434	30-210 RBLK	4/18 x 5 3/8 x 3	1.25	CB124	0.30
CF435	30-220 RBLK	4/18 x 7 3/8 x 3	1.87	CB125	0.30
CF436	30-230 RBLK	5 1/2 x 10 7/8 x 5	4.35	CD513	0.54
CF437	30-235 RBLK	11 x 10 7/8 x 5	5.04	CD514	0.54
CF438	30-239 RBLK	8 1/4 x 10 3/4 x 7	6.23	CB128	0.61
CF439	30-240 RBLK	8 1/4 x 14 3/4 x 7	8.77	CB129	0.77
CF440	30-250 RBLK	16 1/2 x 14 3/4 x 7	14.87	CB129	0.77

OFFICE PRODUCTS

INSTRUMENTS, SCALES & ELECTRICAL

SHIPPING & PACKAGING

TOOLS & EQUIPMENT

WELDING & METALWORKING

SAFETY EQUIPMENT & SUPPLIES

JANITORIAL & MAINTENANCE

MATERIAL HANDLING & STORAGE



# BINS/SUPPORT RACKS & CABINETS

## QUANTUM™ BINS

- Heavy-duty, virgin, high density polypropylene/polyethylene
- Autoclavable up to 250° F
- Large multiple label slots
- Stackable
- Optional dividers and clear windows available for most units
- Hangs on louvered panels, rails and carts

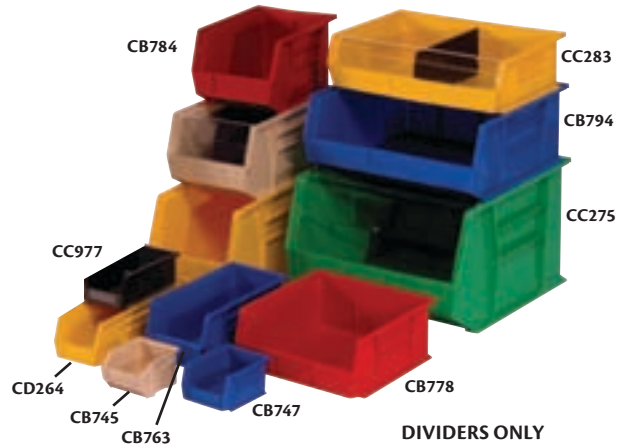

### DIVIDERS ONLY

Black			Blue			Yellow			Red			Ivory			Green			Mfg. No.	Outside Dim.				Qty /Case	Bin load Cap. lbs.	Price /Each	Depth Divider		Clear Window	
Model No.	Model No.	Model No.	Model No.	Model No.	Model No.	Model No.	Model No.	Model No.	Model No.	Model No.	Model No.	Model No.	Model No.	Model No.	Model No.	Model No.	Model No.	Model No.	Model No.	Model No.	Model No.	Model No.	Model No.	Model No.	Model No.	Model No.	Model No.	Model No.	
W"	x	D"	x	H"	W"	x	D"	x	H"	W"	x	D"	x	H"	W"	x	D"	x	H"	W"	x	D"	x	H"	Price /Each	Price /Each	Price /Each	Price /Each	
CC975	CB739	CB741	CB744	CB745	CC264	QUS 200	4 1/8	x	5	x	3	24	8	1.76	CB824	1.41	-	-	-	-	-	-	-	-	-	-	-	-	
CC976	CB747	CB750	CB751	CB753	CC265	QUS 210	4 1/8	x	5 3/8	x	3	24	10	1.98	CB825	1.52	-	-	-	-	-	-	-	-	-	-	-	-	
CC977	CB756	CB757	CB759	CB762	CC266	QUS 220	4 1/8	x	7 3/8	x	3	24	10	2.78	CB826	1.63	-	-	-	-	-	-	-	-	-	-	-	-	
CF376	CF377	CF378	CF379	CF380	CF381	QUS 221	6	x	9 1/4	x	5	12	20	4.65	CF501	2.48	CF560	1.98	-	-	-	-	-	-	-	-	-	-	
CD276	CD249	CD262	CD263	CD264	CD265	QUS 224	4 1/8	x	10 7/8	x	4	12	30	5.10	CD250	2.66	CD266	2.03	-	-	-	-	-	-	-	-	-	-	
CC978	CB763	CB765	CB766	CB768	CC267	QUS 230	5 1/2	x	10 7/8	x	5	12	30	8.50	CB829	2.65	CB814	2.06	-	-	-	-	-	-	-	-	-	-	
CC974	CC971	CC972	CC973	CC990	CC970	QUS 234	5 1/2	x	14 3/4	x	5	12	50	9.97	CC569	3.30	CB814	2.06	-	-	-	-	-	-	-	-	-	-	
CC980	CB775	CB777	CB778	CB780	CC629	QUS 235	11	x	10 7/8	x	5	6	50	12.40	CB829	2.65	CB815	2.96	-	-	-	-	-	-	-	-	-	-	
CC576	CB781	CB783	CB784	CB786	CC270	QUS 239	8 1/4	x	10 3/4	x	7	6	50	12.80	CB830	3.84	CB818	2.69	-	-	-	-	-	-	-	-	-	-	
CC577	CB787	CB789	CB790	CB792	CC271	QUS 240	8 1/4	x	14 3/4	x	7	12	60	15.20	CB831	3.88	CB818	2.69	-	-	-	-	-	-	-	-	-	-	
CF382	CF383	CF384	CF385	CF386	CF387	QUS 241	8 1/4	x	13 5/8	x	6	12	60	16.50	CF394	3.84	CF396	2.68	-	-	-	-	-	-	-	-	-	-	
CF388	CF389	CF390	CF391	CF392	CF393	QUS 242	8 1/4	x	13 5/8	x	8	12	60	18.10	CF395	4.48	CF397	3.11	-	-	-	-	-	-	-	-	-	-	
CC983	CC282	CC283	CC284	CC285	CC286	QUS 245	16 1/2	x	10 7/8	x	5	6	60	20.80	CC297	2.75	CC300	5.85	-	-	-	-	-	-	-	-	-	-	
CC578	CB794	CB795	CB796	CB797	CC272	QUS 250	16 1/2	x	14 3/4	x	7	6	75	23.50	CB831	3.88	CB819	5.95	-	-	-	-	-	-	-	-	-	-	
CC579	CB798	CB800	CB801	CB802	CC273	QUS 255	11	x	16	x	8	4	75	25.50	CB833	7.71	CB820	4.95	-	-	-	-	-	-	-	-	-	-	
CC580	CB803	CB804	CB806	CB807	CC274	QUS 260	11	x	18	x	10	4	75	38.80	CB834	3.97	CB821	5.05	-	-	-	-	-	-	-	-	-	-	
CC581	CC287	CC288	CC289	CC290	CC291	QUS 265	8 1/4	x	18	x	9	6	60	28.10	CC298	6.96	CC301	4.70	-	-	-	-	-	-	-	-	-	-	
CC582	CB808	CB809	CB810	CB811	CC275	QUS 270	16 1/2	x	18	x	11	3	75	42.60	CB835	7.71	CB822	7.11	-	-	-	-	-	-	-	-	-	-	
CD674	CD669	CD670	CD671	CD673	CD672	QUS 275MOB*	16 1/2	x	18	x	14	3	-	88.00	CB835	7.71	CB822	7.11	-	-	-	-	-	-	-	-	-	-	

\* Mobile unit

## OPEN HOPPER STORAGE SHELF UNITS

### QUS 239 SERIES

- 28 QUS 239 Series bins
- 11" L x 8 1/4" W x 7" H
- 8 heavy-duty grey enamel shelves
- Dimensions: 36" W x 12" D x 76" H
- Capacity: 630 lbs. per shelf
- Shipped knocked down



CF118



### QUS 240 SERIES

- 28 QUS 240 Series bins
- 14 3/4" L x 8 1/4" W x 7" H
- 8 heavy-duty grey enamel shelves
- Dimensions: 36" W x 12" D x 76" H
- Capacity: 630 lbs. per shelf
- Shipped knocked down



CF126



### QUS 250 SERIES

- 14 QUS 250 Series bins
- 14 3/4" L x 16 1/2" W x 7" H
- 8 heavy-duty grey enamel shelves
- Dimensions: 36" W x 12" D x 76" H
- Capacity: 630 lbs. per shelf
- Shipped knocked down



CF132



### QUS 240 & 230 SERIES

- 7 QUS 240 Series bins
- 14 3/4" L x 8 1/4" W x 7" H
- 36 QUS 230 Series bins
- 10 7/8" L x 5 1/2" W x 5" H
- 9 heavy-duty grey enamel shelves
- Dimensions: 36" L x 12" D x 76" H
- Capacity: 630 lbs. per shelf
- Shipped knocked down



CF135



Model No.			No. of Shelves			Price /Each		
Black	Blue	Yellow	Red	Ivory	Green	Description	No. of Shelves	Price /Each
<b>QUS 239 SERIES BINS SHELF UNIT</b>								
CF176	CF118	CF119	CF120	CF121	CF122	Starter	8	589.00
CF180	CF140	CF141	CF142	CF143	CF144	Add-On	8	549.00
<b>QUS 240 SERIES BINS SHELF UNIT</b>								
CF178	CF123	CF124	CF125	CF126	CF127	Starter	8	658.00
CF182	CF150	CF151	CF152	CF153	CF154	Add-On	8	618.00

Model No.			No. of Shelves			Price /Each		
Black	Blue	Yellow	Red	Ivory	Green	Description	No. of Shelves	Price /Each
<b>QUS 250 SERIES BINS SHELF UNIT</b>								
CF177	CF128	CF129	CF130	CF131	CF132	Starter	8	559.00
CF181	CF145	CF146	CF147	CF148	CF149	Add-On	8	519.00
<b>QUS 240 &amp; 230 SERIES BINS SHELF UNIT</b>								
CF179	CF133	CF134	CF135	CF136	CF137	Starter	10	677.00
CF183	CF175	CF155	CF156	CF157	CF158	Add-On	10	637.00

## METAL BIN SUPPORT RACKS

- Louvered bin panels can be wall-mounted, attached to back of shelving, mounted on benches, carts, inside cabinets, fastened to slotted angle components or used for service truck interiors
- Bins are easily removed, refilled and replaced
- Each heavy-duty panel is 16-gauge cold-rolled steel
- Slotted holes 3/4" L x 3/8" W at 6" centres simplify installation
- Kleton grey powder coated
- **Installation Note:** Panels must be securely fastened to materials of adequate load bearing strength
- Each panel must be secured vertically at the centre

### BIN QUANTITY TABLE

Quantity of identical plastic bins that fit model CF412 panel

Combined Panel Height 35 3/4" Wide		Bin CB093	Bin CB096	Bin CB099	Bin CB102	Bin CB105	Bin CB108	Bin CB111
1 Panel =	19" H	32	32	18	9	8	8	4
2 Panels =	37" H	72	72	36	18	18	16	8
3 Panels =	55" H	104	104	54	27	28	28	14
4 Panels =	73" H	144	144	72	36	36	36	18

For CF411 Panel, use 1/2 of bin quantities shown above.

## BIN CARTS

- All-welded bin cart
- Work surface made of 14-gauge steel
- Includes bolted on 5" non-marking casters and 2 louvered bin panels
- 1000-lb. capacity
- Durable Kleton blue finish

Model No.	Description	Cart Dimensions				Wt. lbs.	Price /Each		
		W"	x	D"	x	H"			
<b>CART ONLY</b>									
CB365	Cart only	24	x	38 1/2	x	36 1/2	620.00		
<b>CART &amp; BIN COMBINATION</b>									
Blue	Red	Yellow	Green	Stone					
CB366	CB367	CB368	CB689	CB690	24	x	38 1/2 x 36 1/2	133	837.00

### BINS SUPPLIED

Bin Qty	Bin Dimensions				
	W"	x	D"	x	H"
16	8 1/4	x	14 3/4	x	7
4	16 1/2	x	14 3/4	x	7

CF412  
Bins not  
included

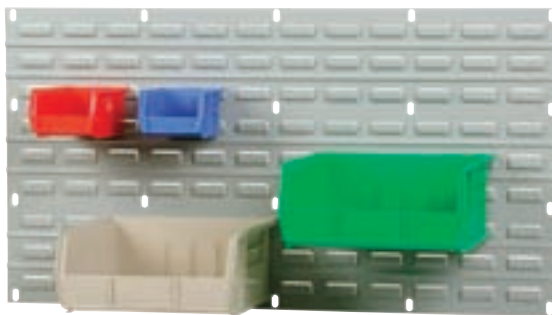

Model No.	Panel Size			Wt. lbs.	Price /Each
		W"	x	H"	
CF411	18	x	19	6	28.70
CF412	36	x	19	12	49.90



CB365



CB367



## Canada's Leading Material Handling Supplier



# BINS/SUPPORT RACKS & CABINETS

## MOBILE BIN RACKS

- Ideal for transportation of small parts
- All-welded mobile bin rack
- Durable Kleton blue enamel finish

### SINGLE SIDED

- Includes 3" casters and two louvered panels
- Capacity: 800 lbs.

### DOUBLE SIDED

- Includes bolted-on 5" non-marking casters and six louvered panels
- Capacity: 1000 lbs.

### RACK ONLY

Model No.	Description	Rack Type	Dimensions			Wt. lbs.	Price /Each
			W"	x	D"	x	H"
CB359	Rack only	Single	36	x	16	x	52
CB649	Rack only	Double	36	x	24	x	63

### RACK & BIN COMBINATION

Model No.					Rack Type	Dimensions			Wt. lbs.	Price /Each
Blue	Red	Yellow	Green	Stone		W"	x	D"		
CB650	CB651	CB652	CB681	CB682	Single	36	x	16	x	52
CB089	CB090	CB091	CB683	CB684	Double	36	x	24	x	63

### BINS SUPPLIED WITH CART & BIN COMBINATION:

Bin Qty	Bin Dimensions				
	W"	x	D"	x	H"
<b>SINGLE SIDED RACK</b>					
36	5 1/2	x	10 7/8	x	5
<b>DOUBLE SIDED RACK</b>					
32	4 1/8	x	5 3/8	x	3
16	4 1/8	x	7 3/8	x	3
24	5 1/2	x	10 7/8	x	5
16	8 1/4	x	14 3/4	x	7
8	16 1/2	x	14 3/4	x	7



## MIX & MATCH

Need more bins that will fit the products on this page?  
See pages 5-6



## STATIONARY BIN RACKS

- Designed to be permanently installed to the floor
- All-welded stationary bin racks
- Constructed of 1 1/4" square tube frame
- Choose from either single or double-sided racks to meet your storage needs
- Durable Kleton blue enamel finish

### RACK ONLY

Model No.	Description	Rack Type	Rack Dimensions			Wt. lbs.	Price /Each
			W"	x	D"	x	H"
CB373	Rack only	Single	36	x	12	x	61
CB653	Rack only	Double	36	x	24	x	61

### RACK/BIN COMBINATION

					Rack Type	Overall Bin Dimensions			Bin Qty	Capacity lbs.	Price /Each		
Blue	Red	Yellow	Green	Stone		W"	x	D"				x	H"
CB654	CB655	CB656	CB685	CB686	Single	8 1/4	x	14 3/4	x	7	28	1680	560.00
CB370	CB371	CB372	CB687	CB688	Double	8 1/4	x	14 3/4	x	7	56	3360	977.00

### ACCESSORIES FOR LOUVERED PANELS

Model No.	Description	Price/Each
CC165	Round Hook, 6"	23.25
CC166	Round Hook, 12"	25.10
CC167	Square Hook, 6"	22.10
CC168	Square Hook, 12"	23.90



Round hook



Square hook

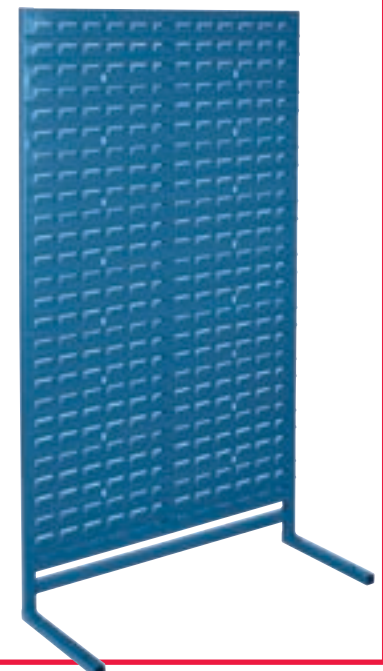



# BINS/SUPPORT RACKS & CABINETS

## BENCH LOUVERED RACKS

- All-welded louvered bench rack
- Provides tool and storage for assembly or repair operations when combined with plastic parts bin
- Durable Kleton blue enamel finish

### 36" FREE STANDING RACKS

- Free standing unit made of 1" square tube frame
- May be placed on any flat surface near a worksite without the need for bolts or fasteners

### 72" BOLT-ON RACKS

- Constructed of 1 1/4" square tube frame
- Designed to be permanently installed on a 72" wide workbench



CB147  
Bench Rack  
with Bins

**MIX & MATCH**  
Need more bins that will fit the products on this page?  
See page 5-6



### RACK ONLY

Model No.	Rack Type	Dimensions					Wt. lbs.	Price /Each
		W"	x	D"	x	H"		
CB363	Free Standing	36	x	10	x	22	22	115.00
CB364	Bolt-On	72	x	15	x	40	95	477.00

### RACK/BIN COMBINATION

Red	Blue	Model No.			Overall Bin Dimensions W" x D" x H"	Bin Qty	Bin Capacity lbs.	Price /Each
		Yellow	Green	Stone				
<b>36" LOUVERED</b>								
CB146	CB145	CB147	CF359	CF360	4 1/8 x 5 3/8 x 3	32	320	156.00
CB152	CB151	CB153	CF361	CF362	4 1/8 x 7 3/8 x 3	32	320	173.00
CB155	CB154	CB156	CF363	CF364	5 1/2 x 10 7/8 x 5	18	540	198.00
<b>72" LOUVERED</b>								
CB173	CB172	CB174	CF365	CF366	4 1/8 x 7 3/8 x 3	144	1440	771.00
CB176	CB175	CB177	CF367	CF368	5 1/2 x 10 7/8 x 5	72	2160	839.00
CB185	CB184	CB186	CF369	CF370	8 1/4 x 14 3/8 x 7	36	2160	820.00

CB176  
Bench rack  
with bins



Work bench not included

## DEEP DOOR COMBINATION CABINETS

- All-welded heavy-duty 16-gauge, combination bin/shelf cabinet
- 4" deep hinged doors
- Unique padlock hasp helps prevent access with bolt cutters
- Powder coated Kleton grey finish
- Padlock sold separately

### 84 BIN CABINETS

- 4 reinforced 16-gauge main adjustable shelves with 500 lbs. capacity per shelf
- Incorporates louvered bin hanging panels welded into the cabinets doors

### CABINET ONLY

Model No.	Description	Dimensions					Wt. lbs.	Price /Each
		W"	x	D"	x	H"		
CB442	Cabinet only	38	x	24	x	72	324	1638.00
FB025	Extra shelf	38	x	18	x	1	18	87.70

### CABINET & BIN COMBINATION

Model No.					Description	Wt. lbs.	Price /Each
Blue	Red	Yellow	Green	Stone			
CB446	CB477	CB448	CB693	CB694	Cabinet and plastic bins	341	1696.00

### BINS SUPPLIED

Bin Qty	Bin Size					Capacity lbs.
	W"	x	D"	x	H"	
84	4 1/8	x	5 3/8	x	3	10



CB446

# BINS/SUPPORT RACKS & CABINETS



## DEEP DOOR COMBINATION CABINETS

- All-welded heavy-duty 16-gauge, combination bin/shelf cabinet
- 4" deep hinged doors
- Unique padlock hasp helps prevent access with bolt cutters
- Powder coated Kleton grey finish
- Padlock sold separately



### 96 BIN CABINETS

- Two reinforced 16-gauge main adjustable shelves with 500 lbs. capacity per shelf
- Incorporates louvered bin hanging panels welded to the cabinet's back and doors

#### CABINET ONLY

Model No.	Description	Dimensions					Wt. lbs.	Price /Each
		W"	x	D"	x	H"		
FH820	Cabinet only	38	x	24	x	72	316	1744.00
FB025	Extra shelf	38	x	18	x	1	18	87.70

#### CABINET & BIN COMBINATION

Blue	Red	Model No.			Description	Wt. lbs.	Price /Each
		Yellow	Green	Stone			
CF371	CF372	CF373	CF374	CF375	Cabinet and plastic bins	359	1918.00

#### BINS SUPPLIED

Bin Qty	Bin Size					Capacity lbs.
	W"	x	D"	x	H"	
84	4 1/8	x	5 3/8	x	3	10
12	5 1/2	x	10 7/8	x	5	30



CF373  
96 Bins

### 98 BIN CABINETS

- 2 reinforced 16-gauge main adjustable shelves with 500-lbs. capacity per shelf
- Incorporates louvered bin hanging panels welded to the cabinet's back and doors

#### CABINET ONLY

Model No.	Description	Dimensions					Wt. lbs.	Price /Each
		W"	x	D"	x	H"		
FH820	Cabinet Only	38	x	24	x	72	316	1744.00
FB025	Extra shelf	38	x	18	x	1	18	87.70

#### CABINET & BIN COMBINATION

Blue	Red	Model No.			Description	Wt. lbs.	Price /Each
		Yellow	Green	Stone			
CF355	CF356	CF354	CF357	CF358	Cabinet and plastic bins	385	2044.00

#### BINS SUPPLIED

Bin Qty	Bin Size					Capacity lbs.
	W"	x	D"	x	H"	
48	5 3/8	x	4 1/8	x	3	10
36	7 3/8	x	4 1/8	x	3	10
8	14 3/4	x	8 1/4	x	7	60
6	14 3/4	x	16 1/2	x	7	75



CF355  
98 Bins

### 118 BIN CABINETS

- Incorporates louvered bin hanging panels welded to the cabinet's back and doors

#### CABINET ONLY

Model No.	Description	Dimensions					Wt. lbs.	Price /Each
		W"	x	D"	x	H"		
CB441	Cabinet only	38	x	24	x	72	316	1569.00

#### CABINET & BIN COMBINATION

Blue	Red	Model No.			Description	Wt. lbs.	Price /Each
		Yellow	Green	Stone			
CB443	CB444	CB445	CB691	CB692	Cabinet and plastic bins	385	1909.00

#### BINS SUPPLIED

Bin Qty	Bin Size					Capacity lbs.
	W"	x	D"	x	H"	
42	5 3/8	x	4 1/8	x	3	10
42	7 3/8	x	4 1/8	x	3	10
18	10 7/8	x	5 1/2	x	5	30
12	14 3/4	x	8 1/4	x	7	60
4	14 3/4	x	16 1/2	x	7	75



CB444  
118 Bins



## CORRUGATED PARTS BINS & DIVIDERS

- Economical standard duty bins constructed of durable corrugated fibreboard
- Ideal for storing any loose small parts
- Assembled easily without staples or tape, just fold
- Bins are designed to hang from the shelf for hands-free access
- Bins dividers not included
- Qty per case: 100
- Shipped knocked down



Standard corrugated bins & dividers



Removable dividers ease handling

### 12" DEEP PARTS BINS, CTN. QTY 100

Dimensions W" x H"	Model No.	Ctn. Wt. lbs.	Price /Each	Model No.	Ctn. Wt. lbs.	Price /Each
2 x 4 1/2	CB063	17	0.82	CB056	22	1.24
3 x 4 1/2	CB064	19	0.88	CB057	27	1.36
4 x 4 1/2	CB065	20	0.97	CB058	30	1.48
6 x 4 1/2	CB066	25	1.04	CB059	38	1.77
8 x 4 1/2	CB067	31	1.18	CB060	45	2.18
9 x 4 1/2	CB068	36	1.27	-	-	-
10 x 4 1/2	CB052	38	1.33	CB054	50	2.51
12 x 4 1/2	CB053	44	1.48	CB055	57	2.86

### 18" DEEP PARTS BINS, CTN. QTY 100

### 3 5/8" DEEP REMOVABLE DIVIDERS, CTN. QTY 300

Dimensions W" x H"	Model No.	Ctn. Wt. lbs.	Price /Each	Dimensions W" x H"	Model No.	Ctn. Wt. lbs.	Price /Each
1 3/4 x 4 1/8	CB071	7	0.76	7 3/4 x 4 1/8	CB075	22	0.97
2 3/4 x 4 1/8	CB072	9	0.79	9 3/4 x 4 1/8	CB069	27	1.04
3 3/4 x 4 1/8	CB073	10	0.82	11 3/4 x 4 1/8	CB070	31	1.10
5 3/4 x 4 1/8	CB074	14	0.85	-	-	-	-

## SINGLE SIDED PICK-RACKS

- Units are free standing, but may be bolted to bench top, floor or wall
- 61" high floor model c/w 48-4" plastic storage bins and 10-6" plastic storage bins or 48-4" corrugated bins and 8-8" corrugated bins
- 21 1/2" high bench model c/w 16-4" plastic storage bins, and 5-6" plastic storage bins or 16-4" corrugated storage bins and 4-8" corrugated storage bins
- Order complete with plastic shelf bins, fibreboard bins or rack only
- Grey enamel finish
- Shipped knocked down

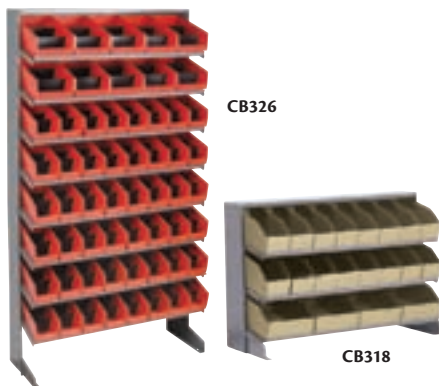

## DOUBLE SIDED MOBILE PICK-RACKS

- 22-gauge steel rack components mounted on a 26" x 36" dolly
- 3" casters
- Each rack accommodates 96-4" wide storage bins and 20-6" wide bins
- Order complete with plastic shelf bins, fibreboard bins or rack only
- Grey enamel finish
- Shipped knocked down

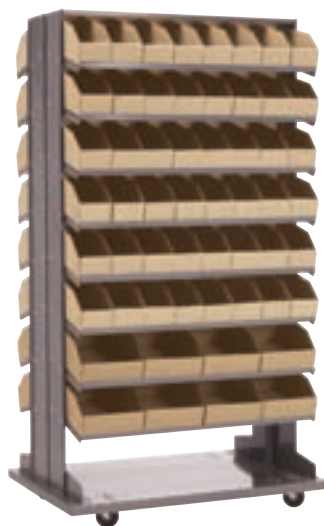

## PARTS STORAGE SHELVING UNITS

- Provides a versatile heavy-duty storage facility for parts storage bins
- 76" high unit c/w 96-4" bins
- 40" high unit c/w 48-4" bins
- Available with plastic shelf bins, fibreboard bins or shelving only
- Grey enamel finish
- Shipped knocked down



Model No.	Dimensions W" x D" x H"	Bin Type	Wt. lbs.	Price /Each	
CB318	32 7/8 x 12 1/8 x 21 1/2	Corrugated	22	124.00	
CB377	32 7/8 x 12 1/8 x 21 1/2	Rack only	17	119.00	
CB323	33 1/2 x 12 1/4 x 61	Corrugated	57	298.00	
CB378	33 1/2 x 12 1/4 x 61	Rack only	45	279.00	
CB320	CB321 CB322	21 1/2	Plastic	25	178.00
CB325	CB326 CB327	61	Plastic	65	443.00

Model No.	Dimensions W" x D" x H"	Bin Type	Wt. lbs.	Price /Each	
CB328	33 1/2 x 12 1/4 x 65	Corrugated	139	790.00	
CB337	33 1/2 x 12 1/4 x 65	Rack only	115	834.00	
CB330	CB331 CB332	65	Plastic	155	1078.00

Model No.	Dimensions W" x D" x H"	Bin Type	Wt. lbs.	Price /Each	
CF048	36 x 12 x 40	Corrugated	90	217.00	
RK203	36 x 12 x 40	Shelving only	80	233.00	
CF184	36 x 12 x 76	Corrugated	163	342.00	
RK241	36 x 12 x 76	Shelving only	144	361.00	
CF049	CF050 CF051	40	Plastic	96	312.00
CF053	CF054 CF055	76	Plastic	176	551.00



# BINS/SUPPORT RACKS & CABINETS

## LABEL HOLDERS

- Clearly identify your shelf/bin contents with the efficient and time-saving Aigner holders
- Versatile, highly protective, easy to read, and even custom designed with a special matte finish, making bar code applications easy
- Ideal for all types of racking, shelving and bin/drawer storage systems
- Labels provided

### HOL-DEX®

- Can be custom cut to your specific size specifications
- Package of 12

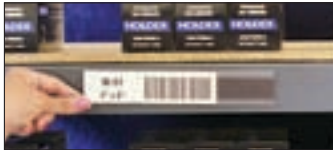

### SUPERSCAN®

- Available in 4 extra large sizes for pallet-racking installation
- Clear plastic matte finish assures precise bar code reading everytime
- Inserts are laser ink jet printer compatible for easy labeling



### SUPERSCAN® (CLEAR ONLY)

Model No.	Dimensions W" x L"	Qty /Box	Price /Box	Model No.	Dimensions W" x L"	Qty /Box	Price /Box
<b>SELF-ADHESIVE</b>				<b>MAGNETIC</b>			
OG356	2 x 3.5	50	39.80	OG357	2 x 3.5	50	63.80
RG670	3 x 5	50	48.10	RG672	3 x 5	50	66.10
RG671	4 x 6	50	56.30	RG673	4 x 6	50	82.60
RG681	5 x 7	25	49.60	RG683	5 x 7	25	63.80

## SLIP 'N STICK™ AISLE SIGNS

- Create your own customised warehouse signs
- Built-in flexible hinge prevents breakage
- Included: 10 sign holders (11" x 8 1/2"), 12 yellow laser/ink jet sheets and instructions



### SNAP-ON

- Snaps into pallet rack assembly holes, can snap out to relocate

Model No. OE798  
Price/Each \$46.60

### SELF-ADHESIVE

- Adheres to flat surfaces, for more permanent applications

Model No. OJ943  
Price/Each \$46.60

## WRITE-ON MAGNETIC TAGS

- A fast, simple and inexpensive means of labeling high-volume applications, primary uses in warehouses and other storage areas
- Newly formulated write-on/wet erase tags come with a strong magnetic backing
- Special wet-erase feature will keep tags clear and clean for extended periods
- Mark with a standard wet erase marker, erase with a damp cloth and remark

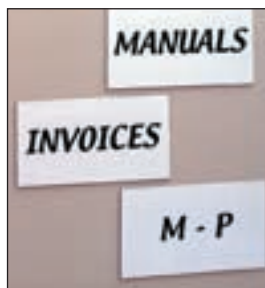

### 50' ROLLS

Model No.	Width"	Price /Each
RH698	1	102.00
RH699	2	173.00
RH700	3	237.00

### TAGS, 25/BOX

Model No.	Dimensions W" x L"	Price /Each
RH696	3 x 6	66.10
RH697	3 x 8	84.80
RH693	2 x 6	49.60

## MAGNETIC TAPES FOR LABELS

- Peel and stick computer printed or hand written labels to non magnetic (matte) side
- Scissor cut to desired length
- Magnetic (shiny) side adheres to metal surface
- Can change label or relocate as required

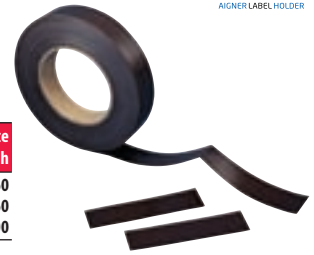

Model No.	Dimensions W" x L'	Price /Each
OJ940	1 x 50	55.60
OJ941	2 x 50	94.60
OJ942	3 x 50	126.00

Custom pre-scored sizes available

## SLIP STRIP™ LABEL HOLDING SYSTEM

- Excellent for displaying bar codes, messages, prices or other information on pallet racking and shelving
- Self-adhesive label/document holder system allows you to change labels without messy adhesive build-up
- 6/pkg

Model No.	Dimensions W" x L'	Price /Each
OE802	1 x 3	53.30
OE803	1 1/4 x 4	69.80
OE804	2 x 4	84.10



## MAGNETIC CARD HOLDERS

- Fast, simple and versatile means of labeling
- Great for metal racks, shelves, bins, drawers and more
- Insertable magnetic C channel design allows for labels to be changed simply by re-marking the paper insert or re-positioning the magnet
- Colour: Black
- Custom cut sizes available on special order
- Inserts included

Model No.	Dimensions W" x L'	Qty /Box	Price /Each
OE250	1 x 3	25	19.50
OE251	1 x 4	25	24.80
OE252	1 x 6	25	33.80
OE253	1 x 8	25	42.80
OE254	2 x 3	25	26.95
OE255	2 x 4	25	33.80
OE256	2 x 6	25	47.30
OE257	2 x 8	25	60.80
OE258	3 x 4	25	47.30
OE259	3 x 6	25	66.80
OE260	3 x 8	25	84.80



## PREMIUM JOB TICKET HOLDERS

- Protect work orders, production schedules, inventory cards and other important documents from excessive handling and wear
- Sewn edges are reinforced with heavy-duty vinyl and a brass eyelet is centered for hanging
- Clear 8 mil. PVC for easy visibility

Model No.	Dimensions W" x L"	Qty /Box	Price /Each
PC529	9 x 6	25	98.40
PC530	12 x 9	25	116.00

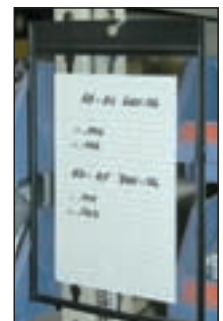

## WIRE-RAC™

- Snap-on holders easily and quickly identify stored contents
- Clear, flexible plastic sleeves fit new or existing wire shelving with 1 1/4" facing; paper inserts included

Model No.	Dim. W" x L"	Qty /Box	Price /Each
RH683	1 5/16 x 3	25	31.50
RH684	1 5/16 x 6	25	55.60
RH685	1 5/16 x 12	12	49.20
RH686	1 5/16 x 24	6	51.10



## QUANTUM™ HULK CONTAINERS

- Heavy-duty injection-molded polypropylene stackable containers
- Organize and store your larger bulky items
- Extra large stacking containers offer a generous 2 to 2 1/2' in length to store your larger items
- Ideal for back-to-back use on 48" pallet rack or heavy-duty, extra deep shelving, and are available in a variety of widths and heights
- Heavy-duty front, back and side grips allow for easy handling
- Optional clear plastic window increases bin capacity and provides a quick view of the bin contents
- Optional dividers maximize flexibility and keep contents organized
- Wide stacking ledge and anti-slide lock keep stacked bins steady and prevent forward shifting
- Waterproof bins resist rust and corrosion
- Bins are autoclavable up to 250°F and are resistant to extreme cold
- **Do not hang on louvered panels or rail systems**



Model No.				Mfg. No.	Outside Dim.					Price /Each	Dividers	Price /Each	Windows	Price /Each
Blue	Red	Yellow	Clear		W"	x	D"	x	H"					
CD545	CD546	CD547	CF525	QUS950	8 1/4	x	23 7/8	x	7	47.10	CD563	11.10	CD569	4.41
CD548	CD549	CD550	CF526	QUS951	8 1/4	x	23 7/8	x	9	47.90	CD564	11.50	CD570	4.48
CD551	CD552	CD553	CF527	QUS952	11	x	23 7/8	x	7	48.80	CD563	11.10	CD571	4.57
CD554	CD555	CD556	CF528	QUS953	11	x	23 7/8	x	10	51.10	CD566	13.20	CD572	9.16
CD557	CD558	CD559	CF529	QUS954	16 1/2	x	23 7/8	x	11	55.50	CD567	14.30	CD573	9.56
CD560	CD561	CD562	CF530	QUS955	18 1/4	x	23 7/8	x	12	56.50	CD568	15.00	CD574	13.40
CF196	CF197	CF198	-	QUS970	8 1/4	x	29 7/8	x	7	62.60	-	-	CD569	4.41
CF199	CF200	CF201	-	QUS973	11	x	29 7/8	x	10	68.60	-	-	CD572	9.16
CF202	CF203	CF204	-	QUS974	16 1/2	x	29 7/8	x	11	75.20	-	-	CD573	9.56
CF205	CF206	CF207	-	QUS975	18 1/4	x	29 7/8	x	12	85.00	-	-	CD574	13.40
CF208	CF209	CF210	-	QUS976	16 1/2	x	29 7/8	x	15	95.00	-	-	CF211	14.80

## STORE MORE™ PLASTIC SHELF BINS

- Durable, high density polypropylene bins
- Economical way to store and display parts and components
- Feature a moulded-in label holder and a built-in rear hang-lock which allows bins to tilt out for complete access when on shelving
- A wide hopper front allows complete access to the contents of the bin
- Edges are reinforced for added strength
- Designed for 12", 18" and 24" deep shelf units, racks or standard shelving
- Bins are waterproof, impervious to most chemicals and unaffected by grease or oil



Store more with 6" high shelf bins



Model No.			Mfg. No.	Outside Dim.					Inside Dim.				Price /Each	Dividers up to 7/bin	Bin Cups/Bin		
Blue	Yellow	Red		W"	x	D"	x	H"	W"	x	D"	x			H"	CD036	CD041
CF212	CF213	CF214	QSB201	4 1/8	x	11 5/8	x	6	3	x	10 1/6	x	6	4.18	CF248	6	2
CF215	CF216	CF217	QSB202	6 5/8	x	11 5/8	x	6	5 1/2	x	10 1/6	x	6	6.39	CF249	9	4
CF218	CF219	CF220	QSB207	8 3/8	x	11 5/8	x	6	7 1/8	x	10 1/6	x	6	7.30	CF250	12	4
CF221	CF222	CF223	QSB209	11 1/8	x	11 5/8	x	6	10	x	10 1/6	x	6	11.20	CF251	18	6
CF224	CF225	CF226	QSB203	4 1/8	x	17 7/8	x	6	3	x	16 1/2	x	6	6.07	CF252	9	3
CF227	CF228	CF229	QSB204	6 5/8	x	17 7/8	x	6	5 1/2	x	16 1/2	x	6	7.99	CF253	15	6
CF230	CF231	CF232	QSB208	8 3/8	x	17 7/8	x	6	7 1/8	x	16 1/2	x	6	11.30	CF254	19	6
CF233	CF234	CF235	QSB210	11 1/8	x	17 7/8	x	6	10	x	16 1/2	x	6	18.80	CF255	29	8
CF236	CF237	CF238	QSB205	4 1/8	x	23 5/8	x	6	3	x	22 1/8	x	6	12.30	CF256	13	4
CF239	CF240	CF241	QSB206	6 5/8	x	23 5/8	x	6	5 1/2	x	22 1/8	x	6	16.60	CF257	21	8
CF242	CF243	CF244	QSB214	8 3/8	x	23 5/8	x	6	7 1/8	x	22 1/8	x	6	21.50	CF258	24	8
CF245	CF246	CF247	QSB216	11 1/8	x	23 5/8	x	6	10	x	22 1/8	x	6	25.60	CF259	35	16

### BIN DIVIDERS

Model No	Price /Each
CF248	1.32
CF249	1.42
CF250	3.32
CF251	3.86
CF252	1.34
CF253	1.42
CF254	3.28
CF255	3.82
CF256	1.34

### BIN DIVIDERS

Model No	Price /Each
CF257	1.42
CF258	3.32
CF259	3.86

### BIN CUPS

Model No	Dimensions			Price /Each		
	W"	x	D"	x	H"	
CD036	3	x	1 3/4	x	3	0.74
CD041	5 1/8	x	2 3/4	x	3	1.42

# BINS/SUPPORT RACKS & CABINETS

## SHELF BINS

- Economical way to store and display parts and components
- Durable polypropylene
- Designed for use on 12", 18" and 24" deep shelving, or vertical storage and retrieval units
- Shelf bins "nest" when empty
- Bin cups and dividers available



The special built-in hanglock catches the underside of the shelf above, allowing each bin to be tilted out for complete access.

Blue	Bin Model No.				Mfg. No.	Outside Dimensions				Price /Each	Dividers, up to 7 per bin	Bin Cup Per Bin				
	Red	Yellow	Clear	Green		W"	x	D"	x			H"	CB379	CB380	CD036	CD041
CB381	CB382	CB383	-	CB696	30-110	2 3/4	x	11 5/8	x	4	2.29	N/A	3	-	-	-
CB384*	CB385*	CB386*	-	CB697*	30-120	4 1/8	x	11 5/8	x	4	2.81	CB420	5	2	-	-
CB393*	CB394*	CB395*	-	CB698*	30-130	6 5/8	x	11 5/8	x	4	3.75	CB421	9	4	-	-
CC393	CC394	CC395	CF531	CD023	QSB107	8 3/8	x	11 5/8	x	4	4.68	CB878	-	-	12	4
CC396	CC397	CC398	CF532	CD026	QSB109	11 1/8	x	11 5/8	x	4	7.01	CB869	-	-	18	6
CB390*	CB391*	CB392*	-	CB699*	30-128	4 1/8	x	17 7/8	x	4	4.17	CF021	8	3	-	-
CB396*	CB397*	CB398*	-	CB700*	30-138	6 5/8	x	17 7/8	x	4	4.59	CB421	15	6	-	-
CC399	CC400	CC401	CF533	CD029	QSB108	8 3/8	x	17 7/8	x	4	7.26	CB867	-	-	19	6
CC402	CC403	CC404	CF534	CD032	QSB110	11 1/8	x	17 7/8	x	4	11.60	CB869	-	-	29	9
CC405	CC406	CC407	CF535	CD045	QSB105	4 1/8	x	23 5/8	x	4	7.64	CB861	-	-	13	4
CC408	CC409	CC423	CF536	CD048	QSB106	6 5/8	x	23 5/8	x	4	10.50	CB862	-	-	21	8
CC411	CC412	CC413	CF537	CD051	QSB114	8 3/8	x	23 5/8	x	4	12.90	CB867	-	-	24	8
CC414	CC415	CC416	CF538	CD054	QSB116	11 1/8	x	23 5/8	x	4	15.90	CB869	-	-	35	16

\*2 full width adjustable/removable dividers included

## BIN DIVIDERS

Model No.	Mfg. No.	Description	Price /Each
CF021	40-128	Divider, 3" wide	0.67
CB420	40-120	Divider, 2 7/8" wide	0.67
CB421	40-130	Divider, 5 1/2" wide	0.84
CB867	DSB107	Divider, 8 1/8" wide	1.73
CB869	DSB109	Divider, 11 1/8" wide	2.00
CB861	DSB101	Divider, 4 1/8" wide	0.67
CB862	DSB102	Divider, 6 5/8" wide	0.73

## BIN CUPS

Model No.	Mfg. No.	Colour	Description	Price /Each
CB379	30-101	White	Bin cup, 3 1/4" x 2"	1.03
CB380	30-102	White	Bin cup, 5" x 2 3/4"	1.89
CD036	QBC111	Yellow	Bin cup, 3 1/4" x 1 3/4"	0.74
CD041	QBC112	Yellow	Bin cup, 5 1/8" x 2 3/4"	1.42

## EXTENDED LABEL HOLDERS

Model No.	Mfg. No.	Colour	Angle	Qty/Box	Price/Box
CF398	ELH410	Black	10°	24	44.80
CF399	ELH415	Black	45°	24	44.80

## RECYCLED SHELF BINS

- Manufactured from recycled 100% post consumer, high density polypropylene
- Available in black only

Model No.	Mfg. No.	Outside Dimensions				Price /Each	Dividers Model No.	Price /Each
		W"	x	D"	x			
CF441	30-110BLK	2 3/4	x	11 5/8	x	4	-	-
CB850	QSB 101 BR	4 1/8	x	11 5/8	x	4	CB861	0.67
CB851	QSB 102 BR	6 5/8	x	11 5/8	x	4	CB862	0.73
CF442	30-128 BLK	4 1/8	x	17 7/8	x	4	CB420	0.67
CB954	QSB 104 BR	6 5/8	x	17 7/8	x	4	CB862	0.73
CB854	QSB 105 BR	4 1/8	x	23 5/8	x	4	CB861	0.67
CB855	QSB 106 BR	6 5/8	x	23 5/8	x	4	CB862	0.73
CB857	QSB 108 BR	8 3/8	x	17 7/8	x	4	CB867	1.73
CB860	QSB 114 BR	8 1/8	x	23 5/8	x	4	CB867	1.73
CC304	QSB 116B	11 1/8	x	23 5/8	x	4	CB869	2.00
CC241	QGH 700 BR	19 7/8	x	15 1/4	x	12 7/16	-	-

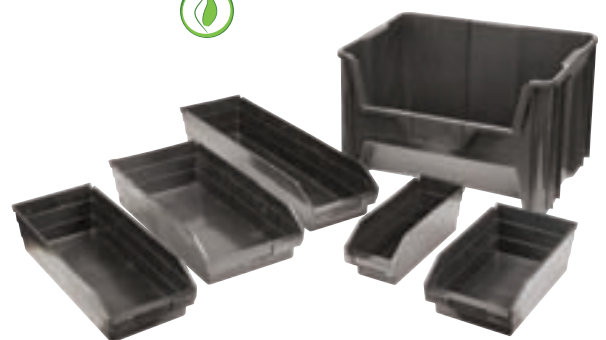



## EURO DRAWERS

- Heavy-duty design for efficient organization of heavy parts, supplies, tools or equipment
- Injection moulded from virgin grade high-impact polystyrene
- 12-gauge thick wall
- Completely waterproof
- Oil and chemical-resistant
- Smooth front curved pull handle has ample room for pressure sensitive identification labels or bar codes
- Front handle has 3/4" opening
- Full width back ledge ensures spill free use



CC502

CC508

CC509

CC515



Add dividers to Euro Drawers for additional storage possibilities!

Model No.				Mfg. No.	Outside Dimensions			Price /Each	Divider Model No.	Price /Each		
Blue	Grey	Red	Yellow		W"	x	D"				x	H"
CE289	CE291	CE292	CE290	QED401	5 9/16	x	11 5/8	x	2 5/8	7.54	CE309	1.15
CE293	CE295	CE296	CE294	QED501	3 3/4	x	11 5/8	x	4 5/8	7.73	CC518	1.20
CC501	CC503	CC504	CC502	QED601	5 9/16	x	11 5/8	x	4 5/8	8.45	CC517	1.36
CC505	CC507	CC508	CC506	QED602	5 9/16	x	17 5/8	x	4 5/8	12.40	CC517	1.36
CC509	CC511	CC512	CC510	QED603	5 9/16	x	23 7/8	x	4 5/8	16.00	CC517	1.36
CC513	CC515	CC516	CC514	QED604	3 3/4	x	17 5/8	x	4 5/8	10.70	CC518	1.20
CE305	CE307	CE308	CE306	QED606	8 3/8	x	17 5/8	x	4 5/8	13.70	CE312	2.12
CE297	CE299	CE300	CE298	QED701	8 3/8	x	11 5/8	x	4 5/8	10.40	CE312	2.12
CE301	CE303	CE304	CE302	QED801	11 1/8	x	11 5/8	x	4 5/8	12.70	CE314	2.48

## EURO DRAWER CLOSED SHELF UNITS

- 13 heavy-duty grey enamel shelves
- Capacity: 630 lbs. per shelf
- Shipped knocked down



### INCLUDES:

- 72 QED601 Series Euro drawers, 11 5/8" W x 5 9/16" D x 4 5/8" H
- Dimensions: 36" W x 12" D x 76" H

Model No.				Description	No. of Shelves	Price /Each
Blue	Yellow	Grey	Red			
CF102	CF103	CF104	CF105	Starter	13	953.00
CF159	CF160	CF161	CF162	Add-On	13	904.00

- 72 QED602 Series Euro drawers 17 5/8" W x 5 9/16" D x 4 5/8" H
- Dimensions: 36" W x 18" D x 76" H

CF106	CF107	CF108	CF109	Starter	13	1334.00
CF163	CF164	CF165	CF166	Add-On	13	1276.00

- 108 QED604 Series Euro drawers 17 5/8" W x 3 3/4" D x 4 5/8" H
- Dimensions: 36" W x 18" D x 76" H

CF110	CF111	CF112	CF113	Starter	13	1603.00
CF167	CF168	CF169	CF170	Add-On	13	1545.00

- 72 QED603 Series Euro drawers 23 7/8" W x 5 9/16" D x 4 5/8" H
- Dimensions: 36" W x 24" D x 76" H

CF114	CF115	CF116	CF117	Starter	13	1693.00
CF171	CF172	CF173	CF174	Add-On	13	1625.00

## RACKBIN™ 42" PALLET RACK CONTAINERS

- Extra-large bins offer a generous 42" in length to store your larger items
- 42" length ensures no wasted space on 42" deep rack
- Heavy-duty front, back and side grips allow for easy handling
- Wide stacking ledge and anti-slide lock keeps stack bins steady and prevent forward shifting
- Have eight 1/4" drill hole pattern on bottom of bin for easy hole insertioin for drainage and air circulation if needed
- Waterproof bins are corrosion free
- Available in blue and gray



Model No.		Mfg. No.	Outside Dimension			Inside Dimensions			Wt. lbs.	Price /Each				
Blue	Gray		W"	x	D"	x	H"	W"			x	D"	x	H"
CF539	CF540	QRB166	16 1/2	x	41 7/8	x	17 1/2	14	x	40 1/8	x	16 1/2	16	164.00
CF541	CF542	QRB206	19 7/8	x	41 7/8	x	17 1/2	17 3/8	x	40 1/8	x	16 1/2	17	181.00
CF543	CF544	QRB246	23 7/8	x	41 7/8	x	17 1/2	21 1/2	x	40 1/8	x	16 1/2	19	199.00

# BINS/SUPPORT RACKS & CABINETS

## MAGNUM

### GIANT STACKING CONTAINERS

- Injection moulded from high density polypropylene
- Extra heavy, double wall thickness with interlock preformed lip allows containers to stack securely
- Moulded carrying handle on backside
- Moulded-in divider and label slots
- Optional windows available
- Can withstand temperatures ranging from -40° to 250°F
- Waterproof, will not rust or corrode
- Unaffected by chemicals and solvents
- Mobile bin comes with 2 swivel, 2 rigid 3" casters
- 250-lb mobile capacity
- 150-lb stack capacity

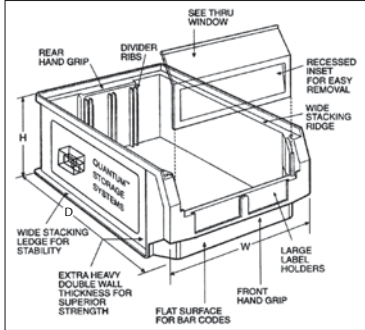

CC447

#### BINS

						Outside Dimensions		Price	DIVIDER		WINDOW			
Blue	Green	Red	Yellow	Mfg. No.	W"	x	D"	x	H"	Model No.	Price /Each	Model No.	Price /Each	
CC361	CC362	CC363	CC364	QMS531	12 3/8	x	19 3/4	x	5 7/8	23.20	CC381	7.57	CC385	6.13
CC365	CC366	CC367	CC368	QMS532	12 3/8	x	19 3/4	x	7 7/8	26.30	CC382	9.11	CC386	7.31
CC369	CC370	CC371	CC372	QMS533	12 3/8	x	19 3/4	x	11 7/8	31.70	CC383	10.90	CC387	7.85
CC373	CC374	CC375	CC376	QMS543	18 3/8	x	19 3/4	x	11 7/8	35.60	CC384	10.90	CC388	8.75
CC377*	CC378*	CC379*	CC380*	QMS743	18 3/8	x	29	x	11 7/8	66.10	-	-	-	-
CC447*	CC449*	CC448*	CC450*	QMS843MOB**	18 3/8	x	29	x	11 7/8	156.00	-	-	-	-

\* Includes heavy-duty spread bar for extra strength and support \*\* Mobile bins

### GIANT OPEN HOPPER BIN SHELVING UNITS

- Dimensions: 18" D x 42" W x 76" H
- Capacity: 480 lbs. per shelf
- Shipped knocked down



CF189



CF193



CF081

#### SERIES QMS516

- 4-QMS543-red, 3-QMS533-blue, 6-QMS532-yellow and 3-QMS531-blue open hopper bins (see chart above for bin dimensions)
- 7 heavy-duty grey enamel shelves

Model No.				Description	Price /Each
Red	Blue	Yellow	Green		
<b>SERIES QMS531</b>					
CF188	CF185	CF186	CF187	Starter	1001.00
CF784	CF785	CF786	CF787	Add-on	941.00
<b>SERIES QMS532</b>					
CF072	CF073	CF074	CF075	Starter	876.00
CF089	CF090	CF091	CF092	Add-on	836.00
<b>SERIES QMS533</b>					
CF080	CF081	CF082	CF083	Starter	745.00
CF097	CF098	CF099	CF100	Add-on	705.00
<b>SERIES QMS543</b>					
CF193	CF190	CF191	CF192	Starter	682.00
CF789	CF790	CF791	CF792	Add-on	643.00
<b>SERIES QMS516</b>					
CF189*				Starter	758.00
CF788*				Add-on	734.00

\* Mixed colors

#### SERIES QMS543

- 10-QMS543 open hopper bins
- 19 3/4" W x 18 3/8" D x 11 7/8" H
- 6 heavy-duty grey enamel shelves



CF074

#### SERIES QMS533

- 15 QMS533 open hopper bins
- 19 3/4" W x 12 3/8" D x 11 7/8" H
- 6 heavy-duty grey enamel shelves



CF187

#### SERIES QMS532

- 21 QMS532 open hopper bins
- 19 3/4" W x 12 3/8" D x 7 7/8" H
- 8 heavy-duty grey enamel shelves

#### SERIES QMS531

- 27-QMS531 open hopper bins
- 19 3/4" W x 12 3/8" D x 5 7/8" H
- 10 heavy-duty grey enamel shelves



## JUMBO PLASTIC CONTAINERS

- Extra-large size provides massive amount of storage capacity
- Guaranteed unbreakable and distortion-free from -40°C to 120°C
- Unaffected by oil, alkaline, and most acids
- Nesting design allows for minimal storage space when not in use
- Stackable for added space savings, up to 4 high
- Outside dimensions: 15 1/2" W x 25" D x 13" H
- Inside dimensions: 13 1/2" W x 22 3/5" D x 12" H
- Capacity: 200 lbs.

KLETON



Model No.	Colour	Price /Each
CF329	Green	37.65
CF327	Red	37.65

Model No.	Colour	Price /Each
CF328	Blue	37.65
CF330	Yellow	37.65

## WIDE SPAN SHELVING WITH JUMBO PLASTIC BINS

- Ideal for storing supplies in warehouses or shops
- No bolt shelving system can be built quickly and easily
- 12-gauge steel posts and 13-gauge beams
- Shelf levels include 5/8" particleboard decking and required tie bars
- Capacity is 800 lbs. per shelf evenly distributed
- Offered configurations include three levels with 12 bins and four levels with 16 bins
- Plastic bin dimensions: 15 1/2" W x 25" D x 13" H
- Assembly required



RL984

KLETON



RL989

Model No.	Shelving Size			No. of Shelves	No. of Bins	Colour	Price /Each
	W"	D"	H"				
RL984	66	18	60	3	12	Red	633.00
RL985	66	18	60	3	12	Blue	633.00
RL986	66	18	60	3	12	Green	633.00
RL987	66	18	60	3	12	Yellow	633.00
RL988	66	18	60	3	12	Red, Blue, Yellow	633.00
RL980	66	18	72	4	16	Red	835.00
RL981	66	18	72	4	16	Blue	835.00
RL982	66	18	72	4	16	Green	835.00
RL983	66	18	72	4	16	Yellow	835.00
RL989	66	18	72	4	16	Red, Blue, Yellow, Green	835.00

## WIRE SHELVING UNITS WITH STORAGE BINS

Same great features as the Kleton chromate wire shelving, but with the added convenience of heavy-duty storage bins.

- Adjustable chromate wire shelves
- Wire shelving resists corrosion and provides greater visibility to stored parts
- Wire shelves prevent build up of dust and dirt
- Bins are unaffected by oil, alkaline, and most acids
- Ideal in production or for parts storage
- NSE certified
- Assembly required
- Unit's total capacity should not exceed 2000-lb.



See page 12 for Aigner Wire-Rac™ labels & holders

KLETON

Model No.	Shelving Size			No. of Shelves	Bin Size			No. of Bins	Colour	Price /Each
	W"	D"	H"		W"	D"	H"			
RL823	36	24	74	5	15 1/2	25	13	8	Blue	618.00
RL824	36	24	74	5	15 1/2	25	13	8	Yellow	618.00
RL825	36	24	74	5	15 1/2	25	13	8	Green	618.00
RL826	36	24	74	5	15 1/2	25	13	8	Red	618.00



RL826



RL825



# STACK & NEST CONTAINERS



- Polyewton Stack-N-Nest containers used in general manufacturing, food processing and distribution applications
- Injection moulded from high density polyethylene
- Will not rust, rot or corrode, resist damaging effects of oil, most chemical solvents, water and steam
- Stack without covers
- Nest at alternating 180° positions when empty
- Withstands wide temperature variances
- Easily cleaned

**Manufactured from FDA compliant materials**

## COVERS

	Model No.			Price /Each
	Grey	Red	Blue	
A.	CA334	CC877	CC883	11.20
B.	CA337	CC880	CC886	11.90
C.	CA335	CC878	CC884	10.60
D.	CA336	CC879	CC885	14.90
E.	CA339	CC882	CC888	20.20
F.	CA338	CC881	CC887	21.60

## CONTAINERS

Grey	Model No.			Mfg No.	Outside Dimensions Top			Outside Dimensions Bottom			Overall Height"	Volume cu.ft.	Nesting Ratio	Wt. lbs.	Uses Cover*	Price /Each
	Red	Blue			L"	x	W"	L"	x	W"						
CA341	CC859	CC868		SN2012-6	20.1	x	13.0	18.5	x	11.5	6.2	0.6	2.1:1	2.1	A	19.60
CA344	CC860	CC869		SN2414-8	24.0	x	14.1	21.8	x	11.5	7.9	1.1	4:1	3.4	B	27.60
CA342	CC861	CC870		SN2013-12	19.4	x	12.9	17.3	x	10.9	12.1	1.3	4:1	3.8	C	30.80
CA343	CC862	CC871		SN2117-12	21.0	x	17.0	18.8	x	15.0	12.0	1.8	4:1	5.0	D	43.90
CA346	CC863	CC872		SN2618-10	26.1	x	18.7	24.0	x	15.9	10.5	2.1	4:1	5.4	E	44.60
CA348	CC864	CC873		SN3022-6	29.6	x	22.4	28.3	x	21.0	6.1	2.1	4:1	4.8	N/A	43.40
CA347	CC865	CC874		SN2818-10	28.4	x	18.7	26.0	x	15.9	10.5	2.3	4:1	5.8	N/A	46.30
CA345	CC866	CC875		SN2420-13	24.0	x	20.0	21.6	x	17.7	13.0	2.7	4:1	6.1	F	44.80
CA349	CC867	CC876		SN3024-15	30.1	x	24.0	27.0	x	21.0	15.1	4.7	4.5:1	11.0	N/A	95.20

## STACK-N-NEST® STORAGE BINS

- Great for storing, assembling and transporting small parts, components and finished goods
- Designed for maximum efficiency and utility
- Set together one way they stack and the other way they nest
- May be used on shelving or stacked up
- Heavy-duty design allows higher stacking
- In the plant, use the same bin for storage, handling, and assembly, no need to transfer contents



Model No.	Colour	Outside Dimensions					Wt. lbs.	Price /Each
		L"	x	W"	x	D"		
CC890	Blue	15 1/4	x	12 1/4	x	6	2	14.10
CC892	Yellow	15 1/4	x	12 1/4	x	6	2	14.10

## STACK & NEST TOTES

- Will stack with or without lids for maximum storage and shipping
- Ability to stack and can be turned 180° to nest when empty
- Textured bottoms ensure safe and easy, non-slip grip transit on conveyors
- Will not rust, corrode or bend out of shape
- Are unaffected by chemicals and are waterproof
- Fit on standard 48" x 40" pallets
- Can withstand temperature ranges from -10°F to 250°F
- Ribs under lip prevent jamming when nested
- Handle grips on either side
- Injection molded high density polypropylene
- FDA compliant materials



Optional lids protect container contents. As pictured, lids can be fastened and locked for added security.



All nine sizes of totes have the ability to use the optional clear label holder. It securely attaches to SNT with or without lid for easy part identification.

### CONTAINERS

Model No.				Mfg. No.	Outside Dimensions			Inside Dimensions			Qty /Case	Price /Each	COVERS				Qty /Case	Price /Each			
Blue	Grey	Red			L"	x	W"	x	H"	L"			x	W"	x	H"			Blue	Grey	Red
CC315	CC316	CC317		SNT180	18	x	11	x	6	15 1/4	x	9 3/8	x	5 7/8	6	15.70	CC342	CC343	CC344	6	10.80
CC318	CC319	CC320		SNT185	18	x	11	x	9	15 1/8	x	9 1/8	x	8 7/8	6	18.90	CC342	CC343	CC344	6	10.80
CC321	CC322	CC323		SNT190	19 1/2	x	15 1/2	x	10	16	x	13 1/4	x	9 7/8	6	29.30	CC345	CC346	CC347	6	14.50
CC324	CC325	CC326		SNT195	19 1/2	x	15 1/2	x	13	15 7/8	x	13 3/8	x	12 7/8	6	30.30	CC345	CC346	CC347	6	14.50
CC327	CC328	CC329		SNT200	19 1/2	x	13 1/2	x	8	16 3/8	x	11 1/2	x	7 7/8	6	25.70	CC348	CC349	CC350	6	16.20
CC330	CC331	CC332		SNT225	23 1/2	x	19 1/2	x	10	19 3/8	x	16 7/8	x	9 7/8	3	30.10	CC351	CC352	CC353	3	21.70
CC333	CC334	CC335		SNT230	23 1/2	x	19 1/2	x	13	19 1/2	x	16 7/8	x	12 7/8	3	35.90	CC351	CC352	CC353	3	21.70
CC336	CC337	CC338		SNT240	23 1/2	x	15 1/2	x	12	19 5/8	x	13	x	11 7/8	3	32.70	CC354	CC355	CC356	3	22.90
CC339	CC340	CC341		SNT300	29 1/2	x	19 1/2	x	15	25 1/8	x	16 5/8	x	14 7/8	3	61.70	CC357	CC358	CC359	3	32.80

### Model No. CC360

Label holder, accommodates up to 3" x 5". Fits all SNT containers.

## QUANTUB NESTING TOTES

- High-density polyethylene
- Rolled top rim for comfortable grip
- Eight 1/4" position drill holes on bottom allow for drainage
- Dimensions: 24 1/2" L x 19" W x 9 1/2" H
- Made of FDA compliant materials

Model No. CD244 Grey

Model No. CD434 Blue

Price/Each \$31.50



## COLLAPSIBLE CONTAINERS

- Polypropylene construction
- Collapses to 21" L x 14" W x 2" H for convenient storage
- Open dimensions 21" L x 14" W x 10 1/2" H
- Reinforced base for added durability
- 16 heavy-duty steel pins built in for increased strength
- Capacity: 160 lbs.

Model No. CF326

Price/Each \$32.35

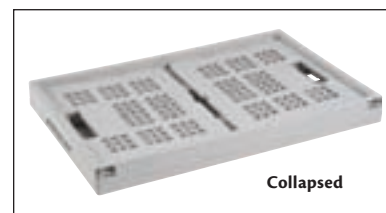

# STACK & NEST CONTAINERS

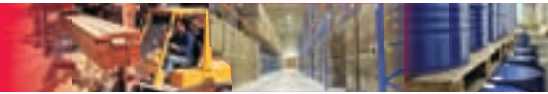

## STACK-N-NEST® PLEXTON CONTAINERS

- Fibreglass reinforced rim
- Ideal solution for heavy-duty storage, work-in-process and distribution applications
- Can withstand temperatures as low as -60°F and as high as 250°F (continuous)
- Resistant to moisture, chemicals, solvents and most oils
- Capacity: 500 lbs. per container



### STACK-N-NEST® CONTAINERS

STACK-N-NEST® CONTAINERS									COVERS			DOLLIES			
Model No.		Outside Dimensions Top			Inside Dimensions Top			Overall Height"	Qty/Case	Price /Each	Model No.		Price /Each	Model No.	Price /Each
Red	Grey	L"	x	W"	L"	x	W"				Red	Grey			
CD179	CD193	17.9	x	10.8	15.9	x	10.1	5	10	30.00	CD207	CD216	24.20	CD225	117.00
CD180	CD194	19.8	x	12.8	18.1	x	11.9	6	10	37.50	CD208	CD217	25.50	CD226	118.00
CD181	CD195	20.6	x	13.0	18.0	x	12.3	8	10	43.50	CF673	CF672	38.65	CD227	130.00
CD182	CD196	24.1	x	11.4	20.0	x	10.7	6.9	10	46.80	CD210	CD219	30.20	CD228	120.00
CD183	CD197	24.1	x	11.4	20.0	x	10.6	9	10	49.70	CD210	CD219	30.20	CD228	120.00
CD184	CD198	24.3	x	14.8	21.7	x	14.0	5.1	8	48.40	CD211	CD220	31.70	CD229	124.00
CD185	CD199	24.3	x	14.8	21.5	x	13.9	8	8	50.80	CD211	CD220	31.70	CD229	124.00
CD186	CD200	25.3	x	18.1	21.4	x	18.1	6.1	10	55.40	CD212	CD221	35.80	CD230	133.00
CD187	CD201	25.3	x	18.1	22.8	x	17.3	10.1	5	67.40	CD212	CD221	35.80	CD230	133.00
CD188	CD202	27.5	x	19.9	23.1	x	18.9	14.0	5	91.50	CD213	CD222	44.80	CD231	143.00
CD189	CD203	29.6	x	13.8	26.7	x	12.9	7	10	55.30	-	-	-	-	-
CD190	CD204	30.6	x	16.9	26.3	x	15.9	11.1	5	89.20	CD214	CD223	38.80	CD232	138.00
CD191	CD205	34.1	x	24.0	30.1	x	21.6	8.1	5	100.00	-	-	-	-	-
CD192	CD206	42.5	x	20.1	38.1	x	19.0	14.1	5	126.00	CD215	CD224	59.70	CD233	188.00

## STACK-N-NEST® PLEXTON HOPPERS

- Fibreglass
- Ideal for heavy parts storage and hardware merchandising
- Nest within their own dimensions and provide positive-lock stacking
- Front label area accommodates adhesive labels



Red	Model No.	Green	Grey	Outside Dimensions						Inside Dimensions				Overall Height"	Wt. lbs.	Price /Each		
				Top			Bottom			Top		Bottom						
				L"	x	W"	L"	x	W"	L"	x	W"	L"	x	W"			
CD267	CD268	CD269		18.1	x	11.4	13.1	x	9.9	16.0	x	8.0	12.8	x	7.5	7.6	3.8	41.70
CD270	CD271	CD272		24.0	x	11.4	19.2	x	9.2	21.5	x	8.8	19.0	x	7.6	7.9	5.1	49.80
CD273	CD274	CD275		24.1	x	16.3	19.1	x	14.4	21.8	x	12.9	18.8	x	11.6	8.0	7.0	62.50

SEE PAGE 12  
FOR ADHESIVE  
LABELS



Can't find what  
you're looking for?  
Call us today!





## GIANT STACKING CONTAINERS

- Designed for multiple applications in recycling, storing parts, tools and warehouse items
- Will stack up to 6 high creating sturdy, tall storage systems
- Large grip side handles
- Extra thick side walls with reinforcing ribs allow for 100 lbs. stack capacity per bin
- Six 1/4" drill holes in bottom allow for drainage
- Outside dimensions: QGH700: 15 1/4" L x 19 7/8" W x 12 7/16" H  
QGH600: 17 1/2" L x 10 7/8" W x 12 1/2" H  
QGH800: 17 1/2" L x 16 1/2" W x 12 1/2" H



### CLEAR WINDOW

Grey	Blue	Model No. Ivory	Black	Red	Mfg. No.	Price /Each	Model No.	Price /Each
CB838	CB839	CB841	CB842	CC305	QGH700*	30.30	CD581	6.29
CD575	CD576	-	-	CD577	QGH600	22.80	CB843	8.48
CD578	CD579	-	-	CD580	QGH800	29.10	CD582	7.90

\*Optional label **CB844** is available for the QGH700 series

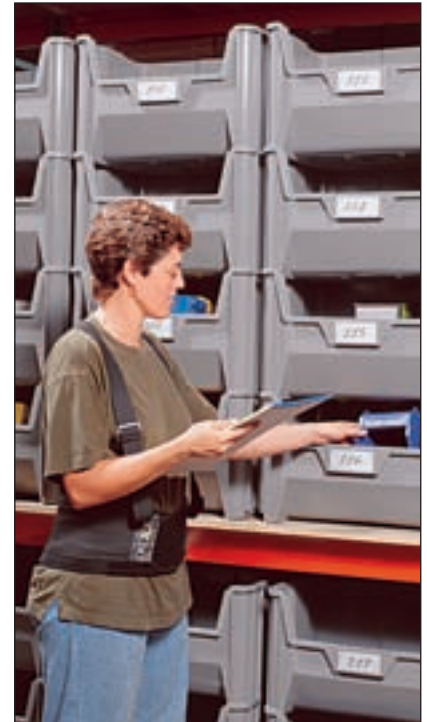

## GIANT STACK CONTAINER SHELF UNITS

- Organize, store and easily access your parts with a complete bin centre
- Strong steel shelving is powder coated and features reinforced cross bracing for increased stability
- Easy assembly
- Bins are included with shelf
- 500-lb capacity per shelf and over 21 cubic feet of storage space
- One colour per unit
- Replacement bins available (See product above)
- Shipped knocked-down



Grey	Model No. Blue	Red	Mfg No.	Dimensions W" x D" x H"	Description	Qty of Bins Included	Price /Each
CF056	CF057	CF066	QSBU-700	42 x 18 x 75	Starter	10	519.00
CF061	CF062	CF067	OSBU-700	42 x 18 x 75	Add-on	10	479.00
CF779	CF260	CD590	QSBU-600	36 x 18 x 75	Starter	15	526.00
CF780	CF781	CF782	OSBU-600	36 x 18 x 75	Add-On	15	481.00

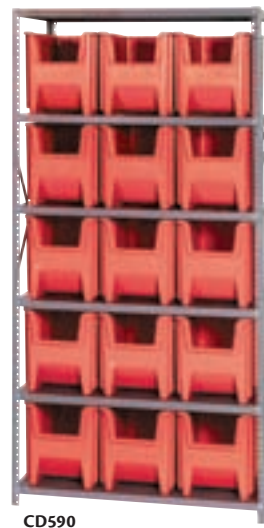

CD590



CF057

SAFETY

GLOVES  
TRAFFIC CONTROL  
SPILL CONTROL  
EYEWEAR

ZENITH®  
Safety Products

# STACK & NEST CONTAINERS

## STAKPAK® PLUS 4845 SYSTEM CONTAINERS

- Stack-only, injection moulded, straight-wall modular containers
- High-density polyethylene (HDPE)
- Reinforced external ribbing adds maximum stacking strength
- Smooth, straight interior walls provide maximum space utilization and easy cleaning

- Modular design optimizes cube on standard 45" x 48" pallet, allows for mixing and matching of various sizes
- Ergonomically designed handles for comfort and safety
- Containers hold up under temperatures from -10°F to 120°F
- Optional covers and cardholders available



48" x 15" (1/3)  
 24" x 15" (1/6)  
 12" x 15" (1/12)  
 12" x 7" (1/24)

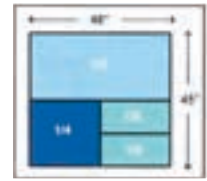

48" x 22" (1/2)  
 24" x 22" (1/4)  
 24" x 11" (1/8)

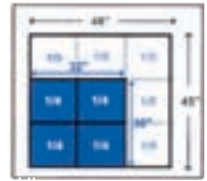

16" x 15" (1/4)  
 on AIAG 30" x 32"  
 15" x 15" (1/9)  
 on AIAG 45" x 48"



12" x 15" (1/6)

### STAKPAK® CONTAINERS

Model No.	Med. Green	Royal Blue	Pallet Modularity (AIAG)	Outside Dimensions	Total Container Height"	Product Clearance"	Volume cu.ft.	48" Trailer Capacity (containers)	Wt. lbs.	Use with Cover	Use with Cardholder	Price /Each
Green	Grey	Blue	30" x 36" 45" x 48"	Top L" x W" Bottom L" x W"		*						
CA498	CA499	CC112	1/12 1/24	12.0 x 7.4 12.0 x 7.4	5.0	4.5	0.1	8640	1.1	A	D	17.70
CA500	CA501	CC113	1/6 1/12	12.0 x 15.0 12.0 x 15.0	5.0	4.4	0.3	4320	1.6		D	18.10
CA502	CA503	CC114	1/6 1/12	12.0 x 15.0 12.0 x 15.0	7.5	6.8	0.5	3456	2.2	B	E	23.50
CA504	CC174	CC115	1/6 1/12	12.0 x 15.0 12.0 x 15.0	9.5	8.8	0.6	2304	2.5		E	24.40
CA507	CA508	CC116	- 1/6	24.0 x 15.0 24.0 x 15.0	5.0	4.5	0.7	2592	3.0		D	27.70
CA509	CA510	CC117	- 1/6	24.0 x 15.0 24.0 x 15.0	7.5	6.8	1.1	1728	3.6	C	E	35.50
CA511	CA512	CC118	- 1/6	24.0 x 15.0 24.0 x 15.0	9.5	8.8	1.4	1296	4.4		E	34.60
CA505	CA506	CC119	- 1/6	24.0 x 15.0 24.0 x 15.0	14.5	13.8	2.2	864	5.7		E	45.20

\* When containers are stacked on top of each other approximately 1/2" is lost to nesting.

### STAKPAK® COVERS

Model No.	Med. Green	Grey	Royal Blue	Dimensions L" x W"	Wt. lbs.	Price /Each
A.	N/A	CA488	N/A	12.0 x 7.4	0.4	11.10
B.	CA489	CA490	CC121	12.0 x 15.0	0.6	12.70
C.	N/A	CA492	CC122	24.0 x 15.0	2.1	17.50

### CARDHOLDERS

Model No.	Dimensions L" x W"	Price /Each
D. CA448	8.5 x 4.0	2.20
E. CA449	8.5 x 4.6	2.20

## FLIPAK®

- Reusable, returnable, attached-lid containers are ideal for use in wholesale product distribution and as picking containers
- Hinged covers with tight interlocking fit provide maximum security and protection

- Stack with lids closed and nest with lids open for optimum use of space in trucks, trailers or on pallets
- Load capacity per container is a maximum of 70-75 lbs.
- Bottom container will support 250 to 300 lbs. when stacked (Please inquire for exact load capacities)

## FLIPAK® POLYETHYLENE PLASTIC (PE) DISTRIBUTION CONTAINERS

- High density polyethylene (HDPE) construction offers maximum product protection from moisture, impact and chemicals



## FLIPAK® CLEAR POLYPROPYLENE PLASTIC (PP) DISTRIBUTION CONTAINERS

- Offer all the same benefits as the polyethylene containers, plus provide easy content identification
- Polypropylene (PP) is the same family as polyethylene
- Polypropylene's advantages over polyethylene include its greater stiffness and elevated use
- Temperature range: 30°F - 150°F



**ORBIS**

Model No.	Outside Dimensions		Overall Height"	Volume Cu. Ft.	Nesting Ratio	Wt. lbs.	Price /Each		
	Top L" x W"	Bottom L" x W"							
Grey	Red	Blue							
<b>LESS THAN 2.0 CU.FT.</b>									
CA452	-	CF265	11.8 x 9.8	9.3 x 7.0	7.7	0.3	2.8:1	2.1	26.30
CA453	-	CF266	15.2 x 10.9	12.8 x 7.8	9.7	0.6	4.0:1	3.0	28.80
CA454	-	-	21.8 x 15.1	18.9 x 13.7	5.5	0.7	3.6:1	4.8	45.70
CA455	-	CF268	19.7 x 11.8	16.9 x 9.3	7.3	0.7	3.0:1	3.4	27.80
CA456	-	-	20.6 x 13.5	18.2 x 11.7	6.5	0.8	2.1:1	5.2	48.20
CA457	-	-	20.6 x 13.2	17.7 x 11.0	11.6	1.4	4.4:1	5.9	51.90
CF559	CF556	CF557	21.9 x 15.2	19.1 x 13.3	9.3	1.3	4.4:1	5.0	30.80
CA461	-	CF273	22.3 x 13.0	19.1 x 10.9	12.8	1.6	3.8:1	6.2	36.40
CA462	CA463	CF274	21.8 x 15.2	18.6 x 12.9	12.9	1.8	4.0:1	6.5	37.30
CA464	-	-	23.5 x 15.7	19.9 x 13.0	13.0	1.9	4.5:1	6.9	48.00
<b>2.0 CU.FT. &amp; GREATER</b>									
CF504	CF503	CF506	26.9 x 16.9	24.4 x 14.7	12.1	2.3	4.2:1	7.8	48.10
CA468	CA469	CF277	23.9 x 19.6	21.1 x 17.1	12.6	2.7	5.3:1	8.4	54.20
CA471	-	-	39.0 x 14.0	36.3 x 11.3	13.0	3.3	4.9:1	10.4	85.20
CF724	CF726	CF725	27.9 x 20.9	25.8 x 18.8	15.2	4.0	2.7:1	12.0	81.70
CA475	-	-	30.0 x 22.0	27.4 x 19.4	20.5	6.1	4.0:1	17.0	183.00

**ORBIS**

Model No.	Outside Dimensions		Overall Height"	Volume Cu. Ft.	Nesting Ratio	Wt. lbs.	Price /Each
	Top L" x W"	Bottom L" x W"					
<b>LESS THAN 2.0 CU.FT.</b>							
CC128	11.8 x 9.8	9.3 x 7.0	7.7	0.3	2.8:1	2.1	28.40
CC129	15.2 x 10.9	12.8 x 7.8	9.7	0.6	4.0:1	3.0	33.00
CC130	19.7 x 11.8	16.9 x 9.3	7.3	0.7	3.0:1	3.4	36.20
CF558	21.9 x 15.2	19.1 x 13.3	9.3	1.3	4.4:1	5.0	46.90
CC132	21.8 x 15.2	18.6 x 12.9	12.9	1.8	4.0:1	6.2	55.40
<b>2.0 CU.FT. &amp; GREATER</b>							
CF505	26.9 x 16.9	24.4 x 14.7	12.1	2.3	5.3:1	7.8	64.30

## FLIP TOP ECONOMY CONTAINERS

- Stacks when lid is closed
- Nests when empty
- Recessed carry handles
- Dimensions: 21 1/2" L x 15" W x 12 1/2" H
- Capacity: 45 litres
- Weight: 5 lbs.

### TRANSLUCENT

Model No. CD383 Black Top  
Model No. CF555 Red Top  
Price/Each \$12.79

### GREY

Model No. CD459  
Price/Each \$12.79



**IP**  
INTEGRATED PLASTICS



# DISTRIBUTION CONTAINERS

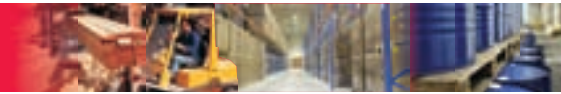

## DIVIDER BOX® CONTAINERS

- Divider Box® (DC) series containers are injection-molded HDPE
- **DG** series are made of FDA compliant materials
- Large, flat areas on all four sides for content identification
- Comfort grip handle
- Stacking rims and multi-ribbed external sides provide high impact strength
- All containers can be divided into compartments by length and/or width
- Molded-in stacking ridge assures containers will stack securely with or without covers
- One set of cardholder snaps and security tie holes on two ends included on **DC** models only
- Full range of optional accessories available including velcro card holders for **DG** models and snap on card holders for **DC** models, vertical dividers and covers
- Optional dolly (**CF400**) allows for easy transport



Grey	Model No.		Mfg. No.	Dimensions									Volume Cu. Ft.	Wt. lbs.	Uses Accessories	Price /Each	
	Red	Blue		L"	x	W"	x	H"	L"	x	W"	x					H"
CA562	CC833	CC846	DC1025	10.8	x	8.3	x	2.5	9.2	x	6.6	x	2.5	0.07	0.5	A	10.10
CC641	CC934	CC946	DG91035	10.9	x	8.3	x	3.5	9.2	x	6.6	x	3.0	0.10	0.9	B	10.80
CC642	CC935	CC947	DG91050	10.9	x	8.3	x	5.0	9.2	x	6.6	x	4.5	0.19	1.2	C	11.20
CA565	CC836	CC849	DC2025	16.5	x	10.9	x	2.5	14.8	x	9.2	x	2.5	0.16	0.9	D	12.90
CC643	CC936	CC948	DG92035	16.5	x	10.9	x	3.5	14.9	x	9.3	x	3.0	0.24	1.42	E	14.00
CC644	CC937	CC949	DG92060	16.5	x	10.9	x	6.0	14.9	x	9.3	x	5.5	0.44	1.88	F	19.60
CA566	CC840	CC853	DC2070	16.5	x	10.9	x	7.0	15.0	x	9.3	x	7.0	0.51	1.7	G	21.50
CC645	CC938	CC950	DG92080	16.5	x	10.9	x	8.0	14.9	x	9.3	x	7.5	0.60	2.5	H	23.80
CC646	CC939	CC951	DG93030	22.5	x	17.5	x	3.0	20.6	x	15.6	x	2.5	0.44	2.5	I	26.30
CA567	CC842	CC855	DC3050	22.4	x	17.4	x	5.0	20.3	x	15.3	x	5.0	0.79	2.6	J	25.00
CC647	CC940	CC952	DG93060	22.5	x	17.5	x	6.0	20.6	x	15.6	x	5.5	0.97	4	K	31.10
CC648	CC941	CC953	DG93080	22.5	x	17.5	x	8.0	20.6	x	15.6	x	7.5	1.32	4.67	L	38.80
CC649	CC942	CC954	DG93120	22.5	x	17.5	x	12.0	20.6	x	15.6	x	11.5	2.03	5.67	M	36.30

### ACCESSORIES

Short Dividers			Long Dividers			Clear Lids		Snap-on or Velcro Cardholders	
Model No.	No. of Slots	Price /Each	Model No.	No. of Slots	Price /Each	Model No.	Price /Each	Model No.	Price /Each
A. CA568	7	1.35	CA571	5	1.43	CA556**	10.40	CC314	2.20
B. CC659	7	1.58	CC650	5	2.20	CD437*	8.71	CF351	6.19
C. CC660	7	1.61	CC651	5	2.35	CD437*	8.71	CF352	6.62
D. CA571	11	1.43	CA577	7	2.09	CA559/CA561**	11.50	CC314	2.20
E. CC661	11	2.20	CC652	7	3.24	CD438*	12.70	CF351	6.19
F. CC662	11	2.72	CC653	7	3.29	CD438*	12.70	CF352	6.62
G. CA575	11	3.31	CA581	7	3.64	CA559/CA561**	13.50	CA446/CC314	2.20
H. CC663	11	2.92	CC654	7	3.94	CD438*	12.70	CF353	6.97
I. CC664	15	3.94	CC655	11	4.32	CD439*	23.60	CF351	6.19
J. CA584	15	3.07	CA588	11	3.39	CD456**	26.10	CA446/CC314	2.20
K. CC665	15	3.98	CC656	11	4.55	CD439*	23.60	CF352	6.62
L. CC666	15	5.23	CC657	11	5.88	CD439*	23.60	CF353	6.97
M. CC667	15	9.70	CC658	11	10.70	CD439*	23.60	CF353	6.97

\* Grey, red and blue covers available \*\* Grey and blue covers available

# DISTRIBUTION CONTAINERS



## ESD DIVIDER BOXES

- Provide conductive and shielding protection for use in electronics manufacturing
- All boxes can be divided into compartments by length and/or width
- Dividers are on 1.25" centres
- Made of permanently conductive black, carbon-filled, injection molded polypropylene copolymer resin
- A Faraday cage is created when used with ESD safe divider box covers
- Unaffected by washing or humidity
- Static decay rate from 5000 volts to 0 of less than two seconds
- Surface resistivity of  $< 1.0 \times 10^5$  ohms/square

Model No.	Outside Dim. Top			Outside Dim. Bottom			Overall Height"	Vol. Cu. Ft.	Wt. lbs.	Price /Each	Short Dividers			Long Dividers			Covers	
	L"	x	W"	L"	x	W"					Model No.	Max. Dividers	Price /Each	Model No.	Max. Dividers	Price /Each	Model No.	Price /Each
<b>CONDUCTIVE BINS</b>																		
CB935	10.8	x	8.3	9.8	x	7.3	2.5	.07	.5	18.60	CB938	7	2.14	CB939	5	2.14	CB911	8.44
CB936	10.8	x	8.3	9.8	x	7.3	3.5	.11	.7	20.70	CB940	7	2.14	CB942	5	3.21	CB911	8.44
CB909	10.8	x	8.3	9.8	x	7.3	5	.16	.9	24.90	CB907	7	3.07	CB908	5	3.83	CB911	8.44
CB910	16.5	x	10.9	15.5	x	9.9	2.5	.16	1.0	27.10	CB939	11	2.14	CB945	7	3.21	CB923	17.40
CB913	16.5	x	10.9	15.5	x	9.9	3.5	.24	1.1	29.10	CB942	11	3.21	CB947	7	5.34	CB923	17.40
CB914	16.5	x	10.9	15.5	x	9.9	5	.36	1.4	33.70	CB908	11	3.83	CB924	7	6.41	CB923	17.40
CB915	16.5	x	10.9	15.5	x	9.9	6	.43	1.6	35.60	CB925	11	5.34	CB926	7	6.41	CB923	17.40
CB937	16.5	x	10.9	15.5	x	9.9	7.0	.51	1.9	44.10	CB941	11	6.41	CB943	7	8.55	CB923	17.40
CB916	16.5	x	10.9	15.5	x	9.9	8	.59	2	46.50	CB927	11	6.41	CB928	7	9.62	CB923	17.40
CB912	22.4	x	17.4	20.9	x	15.9	5	.79	2.8	63.40	CB944	15	6.41	CB946	11	7.48	CB921	29.80
CB917	22.4	x	17.4	20.9	x	15.9	6	.97	3.0	70.70	CB929	15	7.48	CB930	11	8.55	CB921	29.80
CB918	22.4	x	17.4	20.9	x	15.9	8	1.32	4.0	83.00	CB931	15	8.55	CB934	11	10.60	CB921	29.80
CB919	22.4	x	17.4	20.9	x	15.9	12	2	6	99.10	CB932	15	17.40	CB933	11	18.30	CB921	29.80

## ESD TRAYS

- Trays provide conductive and shielding protection for use in electronics manufacturing
- Resistant to abrasion and chemicals
- Easy to clean with steam or water (temperature range: -60°F to 250°F)
- Trays are permanently dissipative and are unaffected by washing



Model No.	Dimensions				Wt. lbs.	Price /Each
	L"	x	W"	x	H"	
CF261	18	x	12	x	1	34.56
CF262	18	x	14	x	1	34.74

Model No.	Dimensions				Wt. lbs.	Price /Each
	L"	x	W"	x	H"	
CF263	20.36	x	15.13	x	1	38.88
CF264	25.75	x	17.88	x	1.1	39.69



## RECYCLED BINS

- Manufactured from recycled, 100% post consumer, high density polypropylene
- Can be stacked or hung in louvered panels
- Available in black only



Model No.	Mfg. No.	Outside Dimensions			Price /Each	Dividers Model No.	Price /Each		
		W"	x	D"	x	H"			
CC552	QUS200BR	4 1/8	x	5	x	3	2.19	CB824	1.41
CC553	QUS210BR	4 1/8	x	5 3/8	x	3	2.19	CB825	1.52
CC554	QUS220BR	4 1/8	x	7 3/8	x	3	3.83	CB826	1.63
CE872	QUS224BR	4 1/8	x	10 7/8	x	4	5.72	CD250	2.66
CC555	QUS230BR	5 1/2	x	10 7/8	x	5	9.55	CB829	2.65
CC557	QUS234BR	5 1/2	x	14 3/4	x	5	11.10	CC569	3.30
CC558	QUS235BR	11	x	10 7/8	x	5	14.50	CB829	2.65
CC559	QUS239BR	8 1/4	x	10 3/4	x	7	15.90	CB830	3.84
CC560	QUS240BR	8 1/4	x	14 3/4	x	7	18.70	CB831	3.88
CC561	QUS245BR	16 1/2	x	10 7/8	x	5	22.10	CC297	2.75
CC562	QUS250BR	16 1/2	x	14 3/4	x	7	26.30	CB831	3.88
CC563	QUS255BR	11	x	16	x	8	28.70	CB833	7.71
CC564	QUS260BR	11	x	18	x	10	43.10	CB834	3.97
CC565	QUS265BR	8 1/4	x	18	x	9	31.60	CC298	6.96
CC566	QUS270BR	16 1/2	x	18	x	11	47.70	CB835	7.71

## RECYCLED SHELF BINS

- Manufactured from recycled 100% post consumer, high density polypropylene
- Available in black only



Model No.	Mfg. No.	Outside Dimensions			Price /Each	Dividers Model No.	Price /Each		
		W"	x	D"	x	H"			
CB850	QSB 101 BR	4 1/8	x	11 5/8	x	4	2.68	CB861	0.67
CB851	QSB 102 BR	6 5/8	x	11 5/8	x	4	4.24	CB862	0.73
CB954	QSB 104 BR	6 5/8	x	17 7/8	x	4	5.14	CB862	0.73
CB854	QSB 105 BR	4 1/8	x	23 5/8	x	4	7.33	CB861	0.67
CB855	QSB 106 BR	6 5/8	x	23 5/8	x	4	10.20	CB862	0.73
CB857	QSB 108 BR	8 3/8	x	17 7/8	x	4	7.05	CB867	1.73
CB860	QSB 114 BR	8 1/8	x	23 5/8	x	4	12.50	CB867	1.73
CC304	QSB 116B	11 1/8	x	23 5/8	x	4	15.30	CB869	2.00
CC241	QGH 700 BR	19 7/8	x	15 1/4	x	12 7/16	29.40	N/A	-

# FOOD APPROVED BOTTLES & CONTAINERS

## QUANTUM NESTING TOTES

- High-density polyethylene
- Rolled top rim for comfortable grip
- Six 1/4" position drill holes on bottom allow for drainage
- Dimensions: 24 1/2" L x 19" W x 9 1/2" H
- Injection molded high-density polypropylene
- FDA compliant materials



Model No.	Colour	Price /Each
CD244	Grey	31.50
CD434	Blue	31.50

## CROSS STACK BINS

- Ideal for production, assembly and order picking
- Injection molded from high impact polypropylene; will not crack or rust, and easy to clean
- Can be turned 90° to cross stack
- Built-in handle and bottom grooves for easy handling
- Capacity: 100 lbs.
- FDA approved
- Optional clear label holder CC360
- Drill hole pattern on bottom can be opened for drainage purposes



Model No.			Dimensions L" x W" x H	Price /Each	LIDS			Price /Each
Blue	Grey	White			Blue	Grey	White	
CD583	CD584	CD585	17 1/4 x 11 x 12	17.80	CF016	CD586	CF017	11.70
CD247	CD246	CD248	25 1/8 x 16 x 8 1/2	27.70	CF018	CD606	CF019	18.80

## GENERAL PURPOSE UTILITY BRUSHES

- Ergonomic handle with aggressive polyester fibre, 1 3/4" and 1 1/2" trim length and 10" handle
- Utility brush is ideal for counter height cleaning and longer handle is great for reaching into equipment
- Curved ergonomic handle prevents knuckle dusting
- Accepted for use in Canadian Food Processing Facilities



Model No.	Mfg. No.	Description	Length"	Price /Each
JB684	D4W	White, short handle	10	27.40

## DETAIL BRUSHES

- 9" detail brush with stiff fibres is perfect for cleaning hard to reach spaces in machinery, 5/8" trim length
- Contoured handle for ergonomic comfort
- Accepted for use in Canadian Food Processing Facilities



Model No.	Mfg. No.	Description	Length"	Price /Each
JB816	B1606B	Stiff, blue	9	6.68
JB817	B1606G	Stiff, green	9	6.68
JB818	B1606R	Stiff, red	9	6.68
JB819	B1606W	Stiff, white	9	6.68
JB820	B1606Y	Stiff, yellow	9	6.68

## TWISTED IN WIRE BRUSHES (TIW)

- Medium stiff polyester fibre trimmed to 1", 2" and 2 1/2" diameter for cleaning tubes, twisted onto stainless steel wire, cut to 12" and 15"
- These brushes make it possible to clean small diameter vessels and pipes on equipment
- Accepted for use in Canadian Food Processing Facilities

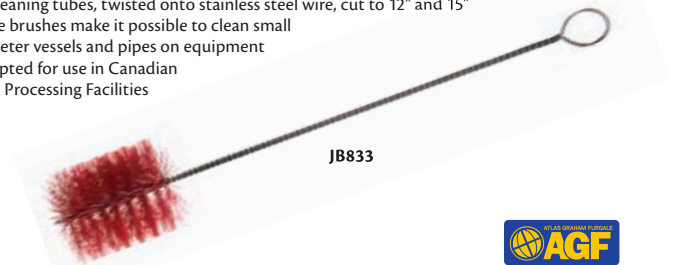

Model No.	Mfg. No.	Description	Dimensions Length" x Dia."	Price /Each
JB691	T832W	White	12 x 1	15.70
JB831	T834B	Blue	15 x 2	20.40
JB832	T834G	Green	15 x 2	20.40
JB833	T834R	Red	15 x 2	20.40
JB834	T834W	White	15 x 2	20.40
JB835	T834Y	Yellow	15 x 2	20.40
JB692	T835W	White	15 x 2 1/2	22.40

## BUS/UTILITY BOXES

- USDA Meat and Poultry Equipment Group Listed and assists in complying w/HACCP guidelines
- Made of durable, commercial grade plastic
  - Reinforced handles, bottom and ribs for added strength
  - Capacity: 17.5 L
  - 20" L x 15" W x 5" H



Model No. CD445 Grey  
Model No. CD446 White  
Price/Each 7.25

Model No. CD662  
Grey cover  
Price/Each 16.90





## CYLINDRICAL TANKS

- Easy to clean and heavy-duty cylindrical tanks
- Ideal for mixing and storage of chemicals and food products
- Molded from 100% virgin LLDPE (linear low density polyethylene)
- Can remain full of liquids at room temperature without support
- An economical alternative to stainless steel tanks
- Naturally translucent so that the product level can be viewed at a glance
- Includes a lid
- Accepted for use in Canadian food processing facilities



CF794



CF795



Model No.	Mfg. No.	Capacity Gallons	Inside Diameter"	Depth"	Wall Thickness"	Tank Weight lbs.	Lid Weight lbs.	Price /Each
CF793	1635	25	16	35	3/16	8	1	94.90
CF794	2234	45	22.5	34	3/16	17	3	219.00
CF795*	3048	125	30	48	1/4	38	-	525.00
CF796	4248	240	42	48	1/4	65	11	619.00

\* Lid not included

## GENERAL PURPOSE PAILS

- Snap on lids available: **Dry seal type** or **gasket type** for liquid handling
- Galvanized steel handles except Model **CB040**
- Lids sold separately



Model No.	Description	Dimensions Dia" x W"	Lid Type	Wt. lbs.	Price /Each
CB040	4-L pail w/plastic handle	8 1/4 x 6	-	0.5	4.79
CB043	11.4-L pail w/metal handle	11 x 9	-	1.1	8.79
CB046	20-L pail w/metal handle	11 7/8 x 15 3/8	-	2.0	14.00

### LIDS

Model No.	Description	Dimensions Dia" x W"	Lid Type	Wt. lbs.	Price /Each
CB039	Lid for pails 4, 5, 6 L w/static joint	8 1/2 x 1/2	Gasket	0.2	2.12
CB041	Lid for pails 11.4 L w/o static joint	11 3/8 x 5/8	Dry Seal	0.3	3.40
CC426	Lid for 20-L pail	12 1/2 x 5/8	Dry Seal	0.4	4.38
CB045	Heavy-duty lid for 20 and 23-L pails w/pouring spout	12 1/8 x 3/4	Gasket	0.6	6.10

## ROUND STORAGE CONTAINERS

- Large ergonomic pull-tab lids makes for easy opening
- Double seal lids help minimize leaking, spoilage and spills
- Dishwasher safe, durable plastic construction
- Ergonomic, easy-grip handles for comfort and control
- Lids sold separately



### CONTAINERS

Model No.	White	Clear	Description	Capacity	Wt. lbs.	Price /Each
CB583	CB584		Round storage container	2 qt/1.89 L	0.35	5.48
CB585	CB586		Round storage container	4 qt/3.79 L	0.58	7.64
CB587	CB588		Round storage container	6 qt/5.68 L	0.73	9.54
CB589	CB590		Round storage container	8 qt/7.57 L	0.85	10.90
CB591	CB592		Round storage container	12 qt/11.36 L	1.25	19.30
CB593	CB594		Round storage container	18 qt/17.03 L	1.8	24.00
CB599	CB600		Round storage container	22 qt/20.82 L	2.4	30.50

### LIDS

Model No.	Description	Wt. lbs.	Price /Each
CB595	Bright yellow lid, fits CB583, CB584, CB585, CB586	0.22	3.50
CB596	Bright yellow lid, fits CB587, CB588, CB589, CB590	0.28	4.16
CB597	Bright yellow lid, fits all other containers	1	10.02

# FOOD APPROVED BOTTLES & CONTAINERS

## NARROW-MOUTH BOTTLES

**NALGENE®**

- These sturdy all-purpose bottles offer a large variety of uses
- Guaranteed leakproof
- Max temp.: 120°C/248°F
- Min.Temp.: -100°C/-148°F



Model No.	Size	Price /Each
HA887	1/4 oz.	0.87
HA888	1/2 oz.	0.99
HA881	1 oz.	1.33
HA882	2 oz.	1.43
HA883	4 oz.	1.82
HA884	8 oz.	2.56
HA885	16 oz.	3.70
HA886	32 oz.	6.05

### DROP DISPENSERS

HB233	1/2 oz.	2.70
HB234	1 oz.	3.75
HB235	2 oz.	4.27

## WIDE-MOUTH BOTTLES

- The larger Nalgene® wide-mouth bottles are great for almost anything
- Guaranteed leakproof
- Max. temp.: 120°C/248°F



**NALGENE®**

Model No.	Size	Price /Each
HB005	1 oz.	2.10
HB006	2 oz.	2.20
HB007	4 oz.	2.65
HB008	8 oz.	3.70
HC678	16 oz.	4.95
HC679	32 oz.	9.25
HB037	1/2 gal.	35.90
HB038	1 gal.	44.30

## ONE GALLON SQUARE BOTTLES

- Heavy-duty walls will not puncture or split under rough conditions
- This 1 gallon leakproof bottle is perfect for solids, powders or liquids
- The convenient wide mouth and handgrips make it easy to fill and pour contents

Model No. HB039  
Price/Each \$54.70



**NALGENE®**

## STRAIGHT-SIDED JARS

- These attractive canister-style jars are ideal for a wide variety of uses
- These jars lock out moisture to help preserve freshness
- Stackable and impact resistant
- Not recommended for liquid storage
- Max temp.: 135°C/275°F
- Min. temp.: -135°C/-211°F



**NALGENE®**

Model No.	Size	Price /Each
HB025	1 oz.	2.50
HB026	2 oz.	2.43
HB027	4 oz.	3.75
HB028	8 oz.	5.65
HB029	16 oz.	6.53
HB030	32 oz.	24.70

## EASY-GRIP SPACE-SAVER BOTTLES RECTANGULAR & SQUARE

### PERFECT FOR SOLIDS, POWDERS OR LIQUIDS!

- Heavy-duty walls will not puncture or split under rough conditions
- Perfect for solids, powders or liquids
- Guaranteed leakproof
- Max Temp.: 120°C/248°F
- Min. Temp.: -100°C/-148°F



**NALGENE®**

Model No.	Size	Price /Each
<b>RECTANGULAR</b>		
HA902	4 oz.	2.15
HA903	8 oz.	2.94
HA904	16 oz.	4.70
HA905	32 oz.	9.60
HA906	64 oz.	20.60
<b>SQUARE</b>		
HB014	2 oz.	2.33
HB015	6 oz.	3.55
HB016	8 oz.	4.68
HB017	16 oz.	6.25
HB018	32 oz.	10.75

## SAMPLE JARS

- Excellent for storing dry materials, medicines, first aid supplies and spare parts for equipment
- Friction fit snap caps



**NALGENE®**

Model No.	Size"	Price /Each
HD015	1 x 1 1/3	0.99

## ROTABIN STORAGE UNITS

- Revolving units allow for greater accessibility and visibility
- Shelves sit securely on ball bearings held with a solid steel pin
- Each shelf rotates smoothly and independently

### 28" DIAMETER

- 6 permanent 14 1/2" wide compartments per shelf
- Model CA221 dividers can be inserted on 1" centres
- Capacity: 500 lbs. per shelf

### 34" DIAMETER

- 5 permanent 21" wide compartments per shelf
- Optional removable pans for 34" diameter units allow for easy parts inventory, restocking, transporting to work area or to get weighted
- Capacity: 500 lbs. per shelf

Model No.	No. of Shelves	No of Pans*	Unit Height"	Wt. lbs.	Price /Each
<b>UNIT ONLY 28" (PANS NOT AVAILABLE)</b>					
CA193	5	-	38	125	1195.00
CA194	6	-	41	144	1356.00
CA195	7	-	47	163	1521.00
CA196	8	-	53	182	1680.00
CA197	9	-	60	201	1844.00
CA198	10	-	66	220	1990.00
<b>UNIT ONLY 34" (PANS NOT INCLUDED)</b>					
CA225	4	60	35	135	1229.00
CA226	5	75	43	162	1440.00
CA227	6	90	50	188	1649.00
CA228	7	105	66	215	1859.00
CA229	8	120	66	240	2069.00
<b>GREY PANS FOR 34" UNIT</b>					
CA258	-	-	-	-	10.40

\*Max number of Pans (Pans Not included)

**DURHAM MFG®**  
Est. 1922



### 44" & 58" DIAMETER

- Designed for storage of larger quantities of small parts or fasteners, or heavier parts
- Scoop compartment design is manufactured from one piece of heavy gauge steel, with dividers welded in place
- 44" diameter units have 5 compartments per shelf, with a 625-lb. capacity each shelf
- 58" diameter units have 10 compartments per shelf, with a 2000 lbs. capacity each shelf
- Grey enamel finish



CA273

Model No.	No. of Shelves	Unit Height"	Wt. lbs.	Price /Each
<b>44" DIAMETER</b>				
CA262	3	34	154	1839.00
CA263	4	45	196	2322.00
CA264	5	56	238	2805.00
CA265	6	67	284	3582.00
<b>58" DIAMETER</b>				
CA273	5	66	563	6479.00

### 17" DIAMETER

- Can be used on counter tops or workbenches
- Each shelf has 4 permanent compartments
- Can have up to 16 compartments per shelf using model CA192 adjustable dividers
- Curved bottom facilitates removal of small parts

Model No.	No. of Shelves	Unit Height"	Wt. Capacity per Shelf lbs.	Wt. lbs.	Price /Each
CA188	4	18 1/2	60	25	302.00
CA189	6	26 1/8	60	34	427.00
CA190	8	34 1/2	60	43	680.00
CA191	10	42 1/8	60	52	682.00

Model No.	Description	Wt. lbs.	Price /Each
CA192	Adjustable Divider	0.02	1.85



CA188



# SMALL PARTS STORAGE

## STEEL PARTS CABINETS

- New design allows 98% use of drawer space to store larger tools or materials
- Housed in all-welded galvanised steel cabinet
- Label with clear plastic cover and divider included with every drawer
- Plastic tabs (except model CF323) and drawer stoppers allow for full extension without risk of spilling
- Grey enamel finish

### KPC-HD HEAVY-DUTY PARTS CABINETS

- Drawer size: 6.5" W x 14.8" D x 4.1" H
- Heavy-duty ABS beige drawers
- Heavy-duty steel shelves provide extra durability



Model No.	No. of Drawers	Dimensions W" x D" x H"	Wt. lbs.	Price /Each
CF323	30	34.6 x 15.7 x 34.6	119	730.00

#### REPLACEMENT PARTS

Model No.	Description	Price /Each
CF324	Drawer	35.65
CF546	Black Divider	2.40
CF343	Label Cover	0.85
CF344	Label	0.40



CF323

### KPC-100 PARTS CABINETS

- Drawer size: 6.4" W x 11.3" D x 2.7" H
- Heavy-duty ABS beige drawers



Model No.	No. of Drawers	Dimensions W" x D" x H"	Wt. lbs.	Price /Each
CF283	12	23 x 11.4 x 13.8	28	252.00
CF284	24	23 x 11.4 x 25.2	47	365.00
CF285	36	23 x 11.4 x 36.9	60	435.00

#### REPLACEMENT PARTS

Model No.	Description	Price /Each
CF286	Drawer	18.95
CF545	Black Divider	1.70
CF287	Clear Divider	1.55
CF338	Label Cover	0.20
CF339	Label	0.30



CF285

CF284

CF283

### KPC-200 PARTS CABINETS

- Drawer size: 5.9" W x 9.8" D x 3.3" H
- Heavy-duty ABS beige drawers



Model No.	No. of Drawers	Dimensions W" x D" x H"	Wt. lbs.	Price /Each
CA889	30	21.3 x 10.4 x 36.9	58	408.00

#### REPLACEMENT PARTS

Model No.	Description	Price /Each
CF481	Drawer	7.70
CF548	Black Divider	0.90
CF522	Label Cover	1.00
CF521	Label	0.40



CA889

## STEEL PARTS CABINETS

- New design allows 98% use of drawer space to store larger tools or materials
- Housed in all-welded galvanised steel cabinet
- Label with clear plastic cover and divider included with every drawer
- Plastic tabs (except model CF323) and drawer stoppers allow for full extension without risk of spilling
- Grey enamel finish

### KPC-300 PARTS CABINETS

- Drawer size: 5.9" W x 9.8" D x 1.6" H
- Clear polystyrene drawers



Model No.	No. of Drawers	Dimensions W" x D" x H"	Wt. lbs.	Price /Each
CF293	18	21.3 x 10.4 x 12.2	25	197.00
CF289	24	14.3 x 10.4 x 22.5	32	262.00
CA890	60	21.3 x 10.4 x 36.9	60	530.00

### REPLACEMENT PARTS

Model No.	Description	Price /Each
CB984	Drawer	6.50
CF549	Black Divider	2.45
CF194	Clear Divider	4.50
CF024	Label Cover	0.60
CF340	Label	0.30

### KPC-400 PARTS CABINETS

- Drawer size: 4.7" W x 8.6" D x 2.7" H
- Heavy-duty ABS beige drawers



Model No.	No. of Drawers	Dimensions W" x D" x H"	Wt. lbs.	Price /Each
CF298	16	23.1 x 8.7 x 13.8	24	210.00
CA891	24	17.3 x 8.7 x 25.6	33	255.00
CA892	48	22.6 x 8.7 x 36.9	58	410.00
CD440*	48	22.6 x 10.8 x 36.9	66.8	566.00

\* Comes with locking door

### REPLACEMENT PARTS

Model No.	Description	Price /Each
CF025	Lock with 2 numbered keys for CD440	2.95
CB985	Drawer	6.25
CF550	Black Divider	0.60
CC309	Clear Divider	0.60
CF341	Label Cover	0.40
CC310	Label	0.25

### KPC-500 PARTS CABINETS

- Drawer size: 3.5" W x 8.6" D x 2.7" H
- Clear polystyrene drawers



Model No.	No. of Drawers	Dimensions W" x D" x H"	Wt. lbs.	Price /Each
CF305	16	18.3 x 8.7 x 13.8	21	197.00
CF304	15	13.9 x 8.7 x 16.3	22	150.00
CF306	20	23.1 x 8.7 x 13.8	27	235.00
CC453	32	18.1 x 8.7 x 25.6	31	270.00
CC454	60	22.6 x 8.7 x 36.9	68	472.00

### REPLACEMENT PARTS

Model No.	Description	Price /Each
CC455	Drawer	5.75
CF551	Black Divider	0.35
CF342	Label Cover	0.40
CD239	Label	0.40



# SMALL PARTS STORAGE

## STEEL PARTS CABINETS

- New design allows 98% use of drawer space to store larger tools or materials
- Housed in all-welded galvanised steel cabinet
- Label with clear plastic cover and divider included with every drawer

- Plastic tabs and drawer stoppers allow for full extension without risk of spilling
- Grey enamel finish

### KPC-600 PARTS CABINETS

- Drawer size: 3.5" W x 8.6" D x 2.2" H
- Clear polystyrene drawers



Model No.	No. of Drawers	Dimensions W" x D" x H"	Wt. lbs.	Price /Each
CF311	18	13.9 x 8.7 x 16.3	19	150.00
CF312	20	18.3 x 8.7 x 13.8	21	198.00
CF313	25	23.1 x 8.7 x 13.8	27	232.00
CF314	40	18.3 x 8.7 x 25.3	40	298.00
CF315	75	23.1 x 8.7 x 36.9	66	523.00

### REPLACEMENT PARTS

Model No.	Description	Price /Each
CF316	Drawer	4.20
CF552	Black Divider	0.80
CF317	Clear Divider	0.75
CF345	Label Cover	0.30
CF346	Label	0.30

### KPC-700 PARTS CABINETS

- Drawer size: 4.7" W x 8.6" D x 2.2" H
- Clear polystyrene drawers



Model No.	No. of Drawers	Dimensions W" x D" x H"	Wt. lbs.	Price /Each
CF318	20	23.1 x 8.7 x 13.6	25	220.00
CF319	30	17.5 x 8.7 x 25.3	40	291.00
CF320	60	23.1 x 8.7 x 36.9	71	466.00

### REPLACEMENT PARTS

Model No.	Description	Price /Each
CF321	Drawer	7.45
CF553	Black Divider	0.80
CF322	Clear Divider	0.75
CF347	Label Cover	0.30
CF348	Label	0.30



## HEAVY-DUTY INDUSTRIAL CAROUSEL DRAWER CABINETS

- Create your customised carousel cabinet
- Each level accommodates 4 parts cabinets with same height
- For a multiple tier cabinet (maximum 3 tiers), you require add-on-shelves and threaded rods as per the following: 1 add-on-shelf model **CF402** for each level of cabinets 14" rod required for each level of **CF312** or **CF305** cabinets 25" rod required for each level of **CC453** or **CF314** cabinets
- Rotational base allows for 800-lb. capacity
- All-welded 11-gauge steel base
- Durable Kleton grey enamel finish



Model No.	Description	Dimensions W" x D" x H"	Wt. lbs.	Price /Each
<b>3 TIER CABINETS KITS</b>				
CF405	192 Drawers	18.3 x 8.7 x 48	392	2497.00
CF406	240 Drawers	18.3 x 8.7 x 48	407	2393.00
CF407	384 Drawers	18.3 x 8.7 x 80	497	3216.00
CF408	480 Drawers	18.3 x 8.7 x 80	600	3116.00

### COMPONENTS

Model No.	Description	Dimensions W" x D" x H"	Wt. lbs.	Price /Each
CF401	Base and Top Cover	27.5 x 27.5 x 4	80	377.00
CF402	Add-on Shelf	27.5 x 27.5 x 1	18	51.20
CF403	Threaded Rod - 14"	0.375 x - x 14	1	19.50
CF404	Threaded Rod - 25"	0.375 x - x 25	1.5	22.30
CF305	Parts Cabinet - 16 Drawers	18.3 x 8.7 x 14	21	197.00
CF312	Parts Cabinet - 20 Drawers	18.3 x 8.7 x 14	21	198.00
CC453	Parts Cabinet - 32 Drawers	18.3 x 8.7 x 25	31	270.00
CF314	Parts Cabinet - 40 Drawers	18.3 x 8.7 x 25	40	298.00

CF408



### Includes:

- Qty: 12 - **CF314** - Cabinet - 40 drawers
- Qty: 1 - **CF401** - Base and Top Cover
- Qty: 2 - **CF404** - Threaded Rod 25"
- Qty: 2 - **CF402** - Add-on Shelf



## CAROUSEL DRAWER CABINETS

- Designed to utilise open and often unused areas such as corners
- Optional turntable can be used to create a rotary carousel unit providing convenience for accessing small parts storage
- All-welded cabinets include clear drawers, dividers and labels
- Cabinet overall dimension: 12" W x 5 3/4" D x 22" H
- Blue enamel finish
- Turntable **CA912** may be set up with up to 3 levels of 4 cabinets per level



CA868



CA867



CA870



CA869

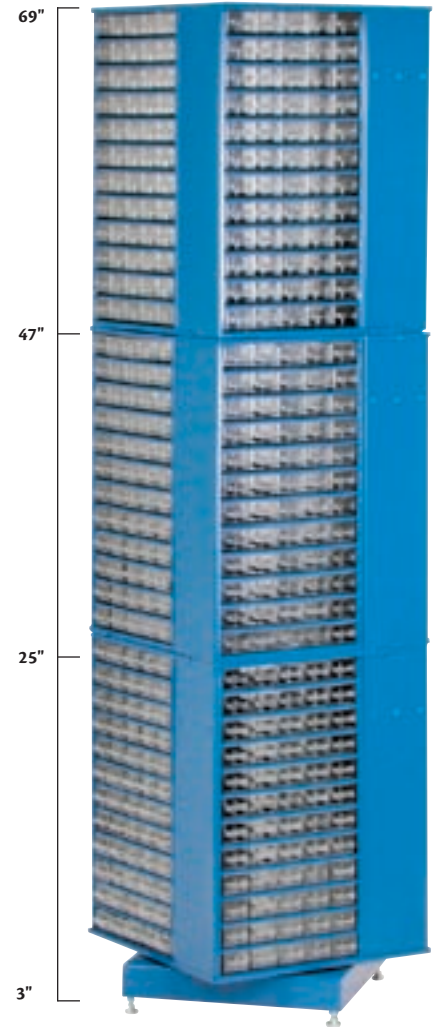

CA912 - Turntable Base  
Turntable unit shown with 12  
CA870 cabinets (sold separately)

Model No.	No. of Drawers	Drawer Model No.	Drawer Dimensions					Wt. lbs.	Price /Each
			W"	x	D"	x	H"		
CA870	60	CD441	2	x	5 5/16	x	13/8	10.7	48.40
CA869	48	CD442	2 1/2	x	5 5/16	x	13/8	10.7	48.40
CA868	30	24 x CD442	2 1/2	x	5 5/16	x	13/8	10.7	48.40
		4 x CD443	5 5/16	x	5 5/16	x	2 1/4		
CA867	16	2 x CD444	11	x	5 5/16	x	2 1/4	10.3	48.40
		CD443	5 5/16	x	5 5/16	x	2 1/4		
CA912	-	3 Tier Turntable Unit Only					40.0	220.00	

## HEAVY-DUTY DRAWER CABINETS

- Heavy-duty parts cabinets feature break resistant high impact clear plastic "scoop" drawers for easy removal of small parts, with two adjustable compartment dividers
- Drawers measure 2 7/8" W x 5 1/2" D x 1 7/8" H each
- Welded steel cabinets are finished in grey powder coat



CA898

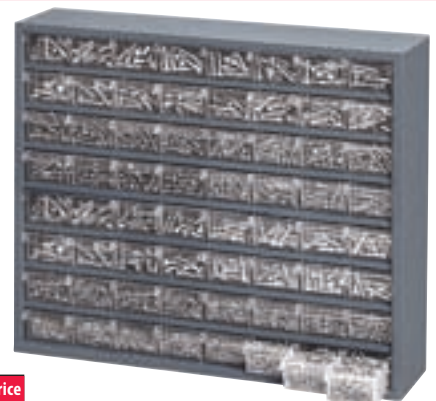

CA899

**DURHAM MFG®**  
Est. 1922

Model No.	No. of Drawers	Cabinet Dimensions					Wt. lbs.	Price /Each
		W"	x	D"	x	H"		
CA899	64	25 1/2	x	6 1/2	x	21 3/4	34	424.00
CA898	20	16 1/2	x	6 1/2	x	11 1/4	12	201.00

# SMALL PARTS STORAGE

## ADD-A-DRAWER®

- Grey plastic drawer modules with clear windows simply slide and lock onto each other
- Can be stacked both horizontally and vertically
- Allows you to create a customised drawer cabinet
- Add on one or more units as more storage capacity is required
- Dividers and labels included



Customize Your Drawer Cabinet!



CA841  
Shown with 2 units



CA877



CD234



CA844  
Shown with 2 units



CA842  
Shown with 2 units



CD235

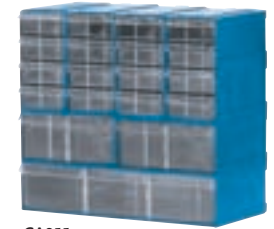

CA855

Model No.	Colour	No. of Drawers	Dimensions			Wt. lbs.	Price /Each
			W"	x	D" x H"		
<b>DRAWER MODULES</b>							
CA840	Grey	2	5	x	5 x 2	0.88	3.87
CA841	Grey	1	2 1/2	x	5 x 2	0.20	2.09
CA842	Grey	1	4 1/2	x	10 x 2 1/2	1.00	7.10
CA844	Grey	1	5	x	5 x 2	0.20	3.14
CA843	Blue	4	3	x	6 x 5 3/4	1.0	3.97
CA845	Blue	2	6	x	6 x 3	1.0	3.97
CA846	Blue	1	6	x	6 x 3	1.0	4.49
CA847	Blue	1	12	x	6 x 3	1.6	6.79
<b>CABINET KITS</b>							
CA877	Blue	32	12	x	6 x 10 1/2	8.0	30.60
CA874	Blue	27	12	x	6 x 17 3/4	11.6	45.70
CA855	Blue	19	12	x	6 x 11 3/4	7.6	30.50
CD234	Grey	4	4 1/2	x	10 1/2 x 10	4	27.10
CD235	Grey	42	15	x	5 x 16	15.5	130.00

## MODULAR PARTS CABINETS

- Organise and control small parts inventory
- Standard cabinets come with light grey polystyrene drawers
- Transparent windows on drawer fronts
- Label holder on drawer pull allows for instant identification
- Comes with two removable dividers per drawer
- Stackable steel cabinet frames finished in grey baked enamel
- Dimensions: 17" W x 11" D x 11" H



CA854

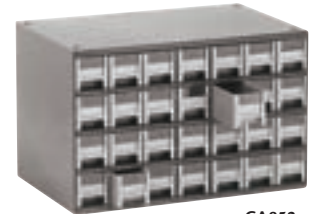

CA853

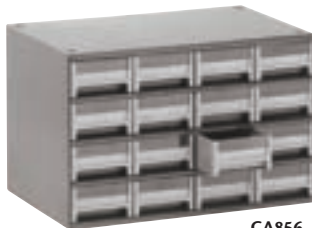

CA856



CA857



CA858

Model No.	Mfg. No.	No. of Drawers	Drawer Dimensions			Wt. lbs.	Price /Each	Dividers Model No.	Price /Each	Replacement Drawers Model No.	Price /Each
			W"	x	D" x H"						
CA853	19228	28	2 3/16	x	10 9/16 x 2 1/16	24	201.00	CB126	1.20	CA859	8.69
CA854	19320	20	3 3/16	x	10 9/16 x 2 1/16	21	201.00	N/A	N/A	CC143	9.60
CA856	19416	16	4	x	10 9/16 x 2 1/8	20	201.00	CA878	1.03	CA860	11.40
CA857	19715	15	3 3/16	x	10 9/16 x 3 1/16	20	201.00	CA880	1.14	CA863	18.80
CA858	19909	9	5 3/16	x	10 9/16 x 3 1/16	18	201.00	CA882	1.43	CA865	19.90



## INTERLOCKING STORAGE CABINETS

- Organise and control small parts inventory
- Clear window allows for easy identification of parts
- Cabinets interlock horizontally and vertically
- Cabinets are made of high impact polystyrene
- Drawer features: removable, recessed handle, label slot, and 7 divider slots
- Complete units available in grey only
- Overall cabinet size: 11 3/4" W x 11 3/4" D x 11" H
- Weight: 10 lbs.
- Units come complete with drawers, clear windows and two dividers per drawer
- Additional drawers can be purchased separately in red, grey, blue & ivory



Model No.	Mfg. No.	No. of Drawers	Price /Each
CD627	QIC161	16 CD608	144.00
CD628	QIC122	12 CD612	147.00
CD629	QIC83	8 CD616	130.00
CD630	QIC64	6 CD620	119.00
CD631	QIC161 & QIC83	8 CD608 & 4 CD616	143.00
CD632	QIC161 & QIC83	12 CD608 & 2 CD616	161.00
CD633	QIC161 & QIC83	4 CD608 & 6 CD616	143.00
CD634	QIC122 & QIC64	8 CD612 & 2 CD620	141.00
CD635	QIC122 & QIC64	4 CD612 & 4 CD620	130.00

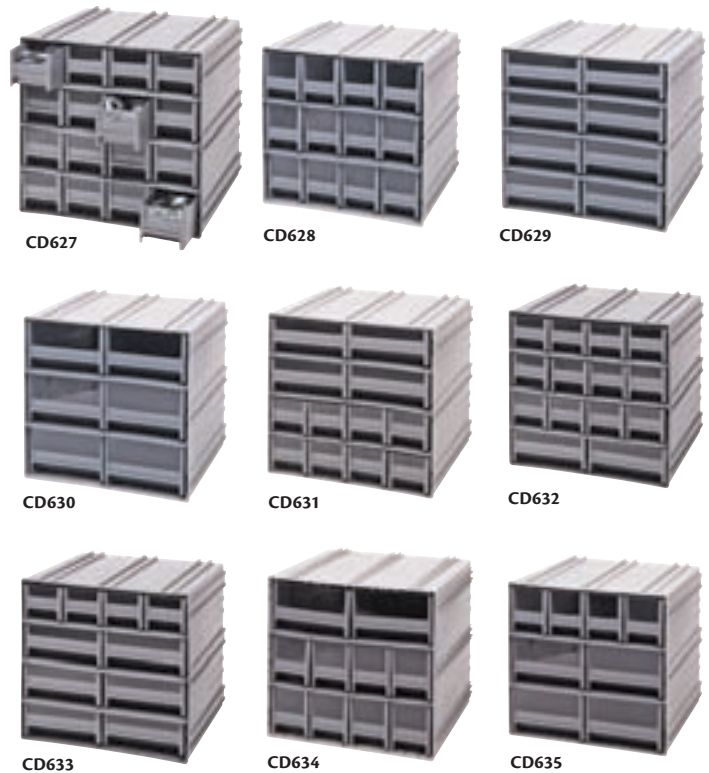

## INTERLOCKING STORAGE CABINET FLOOR STANDS

- Fabricated of heavy-duty 14 gauge steel with a powder coated finish
- Available in three heights: 24", 48" and 70"
- Units can be single sided or double sided
- Double sided units only can be made mobile with CD660 mobilising kit, includes casters and handle
- All single and double sided units must be securely fastened to the floor to ensure stability
- Units include polystyrene drawers, clear windows and two dividers per drawer
- Colour: Grey



Single Model No.	Mfg. No.	No. of Cabinets Single	Price /Each	Double Model No.	No. of Cabinets Double	Price /Each
<b>24" H</b>						
CD636	QIC-124-161	4 CD627	862.00	CD648	8 CD627	1627.00
CD637	QIC-124-122	4 CD628	782.00	CD649	8 CD628	1467.00
CD638	QIC-124-83	4 CD629	721.00	CD650	8 CD629	1345.00
CD639	QIC-124-64	4 CD630	684.00	CD651	8 CD630	1272.00
<b>48" H</b>						
CD640	QIC-148-161	8 CD627	1463.00	CD652	16 CD627	2284.00
CD641	QIC-148-122	8 CD628	1303.00	CD653	16 CD628	2043.00
CD642	QIC-148-83	8 CD629	1181.00	CD654	16 CD629	1862.00
CD643	QIC-148-64	8 CD630	1109.00	CD655	16 CD630	1751.00
<b>70" H</b>						
CD644	QIC-170-161	12 CD627	2108.00	CD656	24 CD627	3387.00
CD645	QIC-170-122	12 CD628	1869.00	CD657	24 CD628	3602.00
CD646	QIC-170-83	12 CD629	1687.00	CD658	24 CD629	3241.00
CD647	QIC-170-64	12 CD630	1578.00	CD659	24 CD630	3020.00



### MOBILISING KIT

Model No. CD660  
Includes casters and handle  
Price/Each \$211.00



# SMALL PARTS STORAGE

## COMPACT POLYPROPYLENE COMPARTMENT BOXES

- High strength, oil resistant polypropylene, boxes with covers fitted with heavy-duty reinforced hinges
- Hinges have a special "stop" feature which allows the cover to remain in open position
- Covers overlap on all sides of the bottom tray
- Two snap latches assure secure closure
- Stackable



### COMPARTMENT BOX CABINETS

- All steel grey powder coat cabinet holds five plastic compartment boxes
- Bolt holes permit stacking and keyhole slots are furnished for wall mounting

**DURHAM MFG**  
Est. 1922



Model No.	Overall Dimensions					No. of Compartments	Compartment Dimensions					Wt. lbs.	Price /Each
	W"	x	D"	x	H"		W"	x	D"	x	H"		
CB513	11	x	6 3/4	x	1 3/4	6	1 3/4	x	6 1/4	x	1 9/16	0.7	6.36
CB509	11	x	6 3/4	x	1 3/4	12	1 3/4	x	3 1/8	x	1 9/16	0.7	6.36
CB511	11	x	6 3/4	x	1 3/4	18	1 3/4	x	2 1/16	x	1 9/16	0.7	6.36
CB507	13 1/8	x	9	x	2 5/16	6	2	x	8 1/2	x	2	0.8	11.30
CB501	13 1/8	x	9	x	2 5/16	12	2	x	4 3/32	x	2	0.8	11.30
CB503	13 1/8	x	9	x	2 5/16	18	2	x	(6) 4 3/4 (12) 2	x	2	0.8	11.30
CB505	13 1/8	x	9	x	2 5/16	24	2	x	2	x	2	0.8	11.30

### COMPARTMENT BOX RACKS

Model No.	Description	Dimensions					Wt. lbs.	Price /Each
		W"	x	D"	x	H"		
CB631	Small Box Rack	11 1/4	x	6 3/4	x	10 3/4	7	68.20
CB632	Large Box Rack	13 1/2	x	9 1/8	x	13 1/4	11	83.80

## COMPARTMENT CASE

- High strength, high quality polypropylene case
- Translucent lid allows for quick view of contents
- Snap latch ensures a secure closure
- Removable dividers allow for different configurations

TLZ117



CF333

**aurora tools**

Model No.	Overall Dimensions			No. of Compartments	Wt. lbs.	Price /Each
	W"	x	D" x H"			
CF333	10 3/4	x	5 3/8 x 1 1/2	Variable up to 17	0.7	5.90
TLZ117	5 3/8	x	5 3/8 x 1 3/8	Variable up to 9	0.3	4.25

## LARGE CASES

### 18 1/2" L X 13" W

- Large "Super Satchel" organise tool cribs, maintenance departments, shop floors and allow complete portability
- See-through lids allow quick identification of contents
- Brass pinned hinges provide strength and durability
- Molded integral feet, making ideal presentation cases

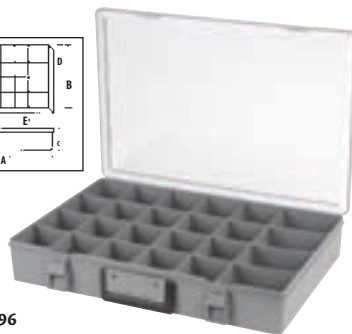
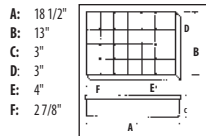

Model No. CB496  
24 compartments  
Weight: 3.5 lbs.  
Price/Each \$51.70

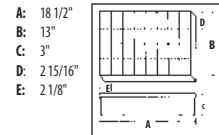

Model No. CB497  
8 to 32 compartments  
24 partitions provided  
Weight: 3.5 lbs.  
Price/Each \$51.70

**F Flambeau**

## SMALL CASES

### 15" L X 11 3/4" W

- Small "Satchel" store and organise large, medium, small and flat parts, removable partitions
- See-through lids allow quick identification of contents
- Brass pinned hinges provide strength and durability
- Divided style (CB499) or double case (CB500) with two cases sonically welded back to back
- Can be stored flat or upright

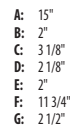

Model No. CB499  
9 to 24 compartments  
Weight: 2.9 lbs.  
Price/Each \$36.30

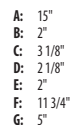

Model No. CB500  
18 to 48 compartments  
Weight: 5.8 lbs.  
Price/Each \$74.00

**F Flambeau**

## COMPARTMENT STEEL SCOOP BOXES

- Manufactured of prime cold rolled steel
- Choose from between 8 to 32 fixed compartment boxes
- Small box dimension: 13 3/8" x 9 1/4" x 2"
- Large box dimension: 18" x 12" x 3"
- High impact plastic dividers have rounded scoops, making it easy to remove small parts
- Finished in rust and acid resistant grey powder coat
- All models have covers designed to stay open
- See chart below for drawer configurations



**DURHAM MFG**  
Est. 1922

### FIXED COMPARTMENT CONFIGURATIONS, ORDER BY NUMBER OF COMPARTMENTS



Number of Compartments	LARGE BOXES 18" X 12" X 3"			SMALL BOXES 13 1/4" X 9 1/4" X 2"		
	Model No.	Wt. lbs.	Price /Each	Model No.	Wt. lbs.	Price /Each
8	-	-	-	CB032	4	27.70
12	CA986	8	41.80	CB015	4	30.70
16	CA989	8	41.80	CB017	4	30.70
20	CA992	8	41.80	CB023	4	30.70
21	CA995	8	41.80	CB026	4	29.70
24	CA997	8	41.80	CB029	4	30.70
32	CB002	8	41.80	-	-	-

## COMPARTMENT BOX CABINETS

- Carriages extend 100% of the boxes depth for easy access to parts
- May be mounted on a raised base
- Available for both small and large box sizes
- Boxes and cabinet are sold separately
- Optional locking hinge prevents boxes from sliding out during transport
- Stackable up to three units high

**DURHAM MFG**  
Est. 1922

Model No.	Dimensions			For Box	Box Capacity	Cradle Cap. lbs.	Price /Each
	W" x D" x H"						
CA963	20 x 15 3/4 x 8 1/8			Large	2	40	126.00
CA965	20 x 15 3/4 x 15			Large	4	40	198.00
FI361*	20 x 15 3/4 x 15			Large	4	75	245.00
CA972	15 1/4 x 11 3/4 x 11 1/4			Small	4	30	155.00
CA975	15 1/4 x 11 3/4 x 16 3/8			Small	6	30	214.00
CB037	Optional Locking Hinge for CA972			-	-	-	13.80
CB038	Optional Locking Hinge for CA965, FI361 and CA975			-	-	-	15.60

\*Heavy-duty



CA965  
Cabinet and boxes sold separately

## ADJUSTABLE COMPARTMENT BOXES

- Adjustable compartments provide the added flexibility of arranging your boxes according to your changing needs
- Removable dividers can be "slotted" into place or removed altogether



**DURHAM MFG**  
Est. 1922

Model No.	Dimensions			Description	Wt. lbs.	Price /Each
	W" x D" x H"					
CA977	18 x 12 x 3			Large	8	42.90
CA979	13 3/8 x 9 1/4 x 2			Small	4	31.70

## CABINET BASES

- Cabinet bases raise your cabinet/box combination 12" off of the floor or workbench
- Models are available to adapt to both small and large box size cabinets



**DURHAM MFG**  
Est. 1922

Model No.	Overall Dimensions			For Box	Wt. lbs.	Price /Each
	W" x D" x H"					
CA980	20 3/8 x 16 x 15 1/8			Large	13	75.20
CA983	15 1/2 x 12 1/8 x 15 1/8			Small	12	67.80

# SMALL PARTS STORAGE

## HEAVY-DUTY TILT BINS

- Extremely durable ABS plastic housing and drawer body
- Transparent polystyrene front window for easy viewing
- Conveniently connects to each other with grooved channels on top, bottom and sides
- Shake resistant design prevents drawers from opening on their own
- Keyholes on back for wall mounting applications
- Colour: Black and Grey



Model No.	No. of Drawers	Bin Dimensions					Cabinet Dimensions					Price /Each
		W"	x	D"	x	H"	W"	x	D"	x	H"	
CF471	8	2 3/4	x	3 1/4	x	3 5/8	11 3/4	x	2 3/4	x	7 7/8	26.70
CF472	6	3 11/16	x	4	x	4 5/8	11 3/4	x	3 1/2	x	9 3/4	24.60
CF473	5	4 1/2	x	4 7/8	x	5 1/2	23 1/2	x	4	x	5 7/8	28.90
CF474	4	5 5/8	x	6 3/8	x	7 1/2	23 1/2	x	5 1/2	x	7 7/8	46.95

## MOBILE TILT BIN RACKS

- Heavy-duty steel frame
- Durable powder coat paint finish on galvanized steel
- 3" swivel casters with brake
- Single or double sided use
- Overall dimensions: 26 1/4" W x 22" D x 57 1/2" H
- Colour: Grey

### MOUNTING CHANNEL CF476 FOR MOBILE TILT BIN RACK

- Takes up to six mounting channels per side
- CF473 tilt bins take up to eight mounting channels per side
- CF471 and CF472 take 2 bin units per level per side



SEE PLASTIC BINS FOR CF502 MOUNTING CHANNEL ON PAGES 5-6

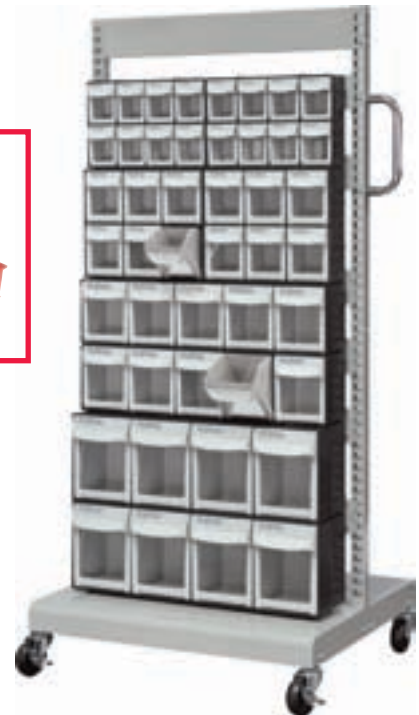

Model No.	Description	Bin Units Included	Price/Each
CF477	Single Sided	2 of each CF471, CF472, CF473, CF474	550.00
CF478	Double Sided	4 of each CF471, CF472, CF473, CF474	845.00
CF475	Cart Only*	-	260.00
CF476	Mounting Channel for Heavy-Duty Tilt Bins	-	12.95
CF502	Mounting Channel for Plastic Bins	-	13.55

\* Mounting channels and bins not included

# GET CLEAN

Industrial handsoap with scrubbing particles for stubborn grease and grime

TRY SOME TODAY!

Model JG223  
See page 327





## TIP-OUT™ BIN MODULAR STORAGE SYSTEMS

- Each bin has a slot for labeling
- Bins can be completely removed for replenishing or cleaning
- Uniform widths of 23.6" (for units of 2 to 9 bins)
- Can be used free-standing or with stands and pedestals
- Transparent compartments tip out for easy access and viewing
- Colour: Beige or Grey



### TILT BINS

Beige	Model No.		Bin Dimensions				Cabinet Dimensions				Wt. lbs.	Price /Each		
	Grey	Mfg. No.	W"	x	D"	x	H"	W"	x	D"			x	H"
CB552	CB553	QTB309	23 1/16	x	13 1/4	x	2 1/2	23 5/8	x	2 1/2	x	3 1/8	2.0	24.30
CB549	CB550	QTB306	3 1/2	x	2 5/8	x	3 3/4	23 5/8	x	3 5/8	x	4 1/2	3.0	28.80
CB546	CB547	QTB305	4 1/4	x	3 3/4	x	5 3/4	23 5/8	x	5 1/4	x	6 1/2	5.0	47.80
CB543	CB544	QTB304	5 5/8	x	5	x	7 1/2	23 5/8	x	6 5/8	x	8 1/8	7.0	67.20
CB540	CB541	QTB303	7 3/8	x	5 7/8	x	8 5/8	23 5/8	x	7 3/4	x	9 1/2	9.0	73.90
CB977	CB978	QTB302	11 1/16	x	8 7/8	x	13 5/8	23 5/8	x	11 7/8	x	13 7/8	14	165.00
CB975	CB976	QTB301	11 1/16	x	8 7/8	x	13 5/8	11 3/16	x	11 7/8	x	13 7/8	7	115.00
CB573	Disc and screw set (2 needed for each bin case)											4.54		

## TIP OUT™ FRAMES



Assembly Required



**FRAME ONLY: BINS NOT INCLUDED**

Model No.	Description	Dimensions				Bin Quantity Table QTB Series Bins						Price /Each	
		W"	x	D"	x	H"	302	303	304	305	306		309
<b>FLOOR STANDS</b>													
CB562	48" 1 Sided	23 5/8	x	8	x	52	3	5	6	7	11	16	337.00
CB563	70" 1 Sided	23 5/8	x	8	x	75	5	7	8	10	15	23	409.00
CB565	48" 2 Sided	23 5/8	x	16	x	52	6	10	12	14	22	32	606.00
CB568	70" 2 Sided	23 5/8	x	16	x	75	10	14	16	20	30	46	671.00
<b>MOBILE FLOOR STANDS</b>													
CB952	48" 2 Sided	23 5/8	x	16	x	52	6	10	12	14	22	32	793.00
CB953	70" 2 Sided	23 5/8	x	16	x	75	10	14	16	20	30	46	859.00
<b>WALL FRAMES</b>													
CB559	48"						3	5	6	7	11	16	119.00
CB561	70"						5	7	8	10	15	23	162.00
CB573*	Disc & Screw Set (2 disks/2 screws)											4.54	

\*Disc & screw set required for each bin cabinet to be mounted on a frame

# SMALL PARTS STORAGE

## SECTIONAL STACKBINS®

### A. SECTIONAL STACKBIN® UNITS

An economical alternative to standard Stackbins®, as individual compartments are created from a standard 37" wide unit divided by welded steel partitions. Each unit may be stacked on a larger, or similar sized unit, with covers, bases, and filler strips available to complete the unit (as shown).

### B. TRUCKS

Available to mobilise your sectional Stackbin® units. Standard blue baked enamel finish for all component

A. Shown with base (sold separately)

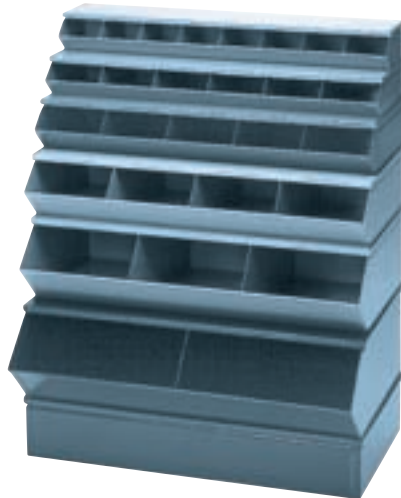

B. Shown with stack bins (not included)



## STACKBIN

Model No.	Dimensions				Bins in Section	Wt. lbs.	Price /Each	
	W"	x	D"	x				H"
<b>A. SECTIONAL STACKBINS®</b>								
CA786*	37	x	8	x	4 1/2	8	11.0	137.00
CA787*	37	x	12	x	4 1/2	6	13.8	143.00
CA788	37	x	15 1/2	x	6	5	20.0	160.00
CA789	37	x	18 3/4	x	7 1/2	4	29.0	186.00
CA790	37	x	20 1/2	x	9 1/2	3	35.0	220.00
CA791	37	x	24	x	11	2	40.0	226.00
<b>B. SECTIONAL TRUCKS (BINS NOT INCLUDED)</b>								
CA809	Fits CA789						39.0	368.00
CA810	Fits CA790						39.0	387.00
CA811	Fits CA791						39.0	387.00

Model No.	Description	Price /Each
<b>SECTIONAL BASES</b>		
CA793	Base for CA788	140.00
CA794	Base for CA789	145.00
CA795	Base for CA790	153.00
CA796	Base for CA791	156.00
<b>SECTIONAL COVERS</b>		
CA797	Cover for CA786	27.00
CA798	Cover for CA787	31.80
CA799	Cover for CA788	35.70
CA800	Cover for CA789	41.70
CA801	Cover for CA790	45.10
CA802	Cover for CA791	52.40

\* No bases available

## PRE-ENGINEERED SECTIONAL SYSTEMS

- Complete with Sectional Stackbin® 6" high base and top cover
- 5000-lb stocking capacity

## STACKBIN

Model No.	Description	Wt. lbs.	Price /Each
<b>USING CA788 SECTIONAL STACKBINS®</b>			
CD354	7 row unit w/35 Comp.	136.5	1297.00
CD355	8 row unit w/40 Comp.	156	1457.00
<b>USING CA789 SECTIONAL STACKBINS®</b>			
CD356	6 row unit w/24 Comp.	174	1303.00
CD357	7 row unit w/28 Comp.	226.5	1488.00
<b>USING CA790 SECTIONAL STACKBINS®</b>			
CD358	5 row unit w/15 Comp.	200	1298.00
CD359	6 row unit w/18 Comp.	235	1518.00
<b>USING CA791 SECTIONAL STACKBINS®</b>			
CD360	4 row unit w/8 Comp.	183.5	1111.00
CD361	5 row unit w/10 Comp.	222.5	1338.00



## STEEL STACKBINS®

- Hopper-front steel Stackbins® are available with capacities from 70 cubic inches up to 5100 cubic inches
- They may be easily stacked one on top of another, or housed in steel Stackracks®, together with Stackracks® base allowing lower units to be removed without disturbing units stacked above them
- Standard blue baked enamel finish



Stackbins®



Covers

Model No.	Capacity Cu. in.	Dimensions W" x D" x H"	Wt. lbs.	Price /Each	Top Cover Model No.	Price /Each	Front Cover Model No.	Price /Each
CA765	70	4 1/2 x 8 x 4 1/2	1.8	27.40	-	-	-	-
CA766	200	5 1/2 x 12 x 4 1/2	3	32.30	CD369	17.80	CA368	14.30
CA767	500	7 1/2 x 15 1/2 x 6	5.5	36.70	CD370	17.80	CA734	14.30
CA768	900	9 x 18 3/4 x 7 1/2	9	46.20	CA706	17.80	CA735	14.30
CA772	1400	10 x 24 x 8	12	58.60	CA710	22.40	CA739	15.50
CA769	1600	12 x 20 1/2 x 9 1/2	12.5	60.50	CA707	21.60	CA736	15.80
CA770	2800	15 x 24 x 11	20.5	84.90	CA708	26.20	CA737	20.40
CA771	5100	18 x 30 x 12	30	149.00	CA709	36.60	CA738	24.60

## PLASTIC STACKBINS®

- Molded polyethylene
- Capacity of 1600 cubic inches
- The exclusive interlocking front bar prevents the bins from spreading under heavy loads
- 12" W x 20 1/2" D x 9 1/2" H



## STACKBIN

Model No.	Wt. lbs.	Cap. lbs.	Price /Each
Blue			
Grey			
CB314	4	50	42.80
CB315			

## STACKRACKS®

- Stackracks® are designed to be teamed up with Stackbins® to create a heavy-duty storage system
- Stackracks® allow for bins to be removed easily from a setup
- Can support any weight that fits within the cube of the coinciding container
- Easily stack together without tools or fasteners and feature Stackbins® patented locking system
- Can be reconfigured or added to at any time



Shown with 10 - CA769 bins, 10 - CA776 single Stackracks and 1 - CA693 Base 2 bins wide



### STACKRACKS®

Model No.	Description	Wt. lbs.	Price /Each
CD447	Stackrack for Bin CA765	3.5	38.00
CA773	Stackrack for Bin CA766	4	39.90
CA774	Stackrack for Bin CA767	5.5	39.90
CA775	Stackrack for Bin CA768	8.5	42.30
CA780	Stackrack for Bin CA772	9	42.30
CA776	Stackrack for Bin CA769	10	50.20
CA778	Stackrack for Bin CA770	12	57.00
CA779	Stackrack for Bin CA771	14	73.80

### STACKRACKS® COVERS

Model No.	Description	Price /Each
CA715	Stackrack Cover for CA775	38.10
CA730	Stackrack Cover for CA780	51.80
CA720	Stackrack Cover for CA776	38.10
CA724	Stackrack Cover for CA778	64.80
CA727	Stackrack Cover for CA779	67.40

## STACKBIN

### 12" HIGH BASES

- Can be butt-up to each other to make continuous rows of storage bins
- Bases are made specifically for each size steel container
- 14-gauge legs and supports
- Spot welded
- Capacity: 1000 lbs.

Model No.	Description	Price /Each
<b>1-BIN WIDE</b>		
CA687	Base for Stackrack CA775	139.00
CA692	Base for Stackrack CA776	151.00
CA696	Base for Stackrack CA778	156.00
CA699	Base for Stackrack CA779	160.00
<b>2-BIN WIDE</b>		
CD448	Base for Stackrack CA774	133.00
CA688	Base for Stackrack CA775	139.00
CA703	Base for Stackrack CA780	151.00
CA693	Base for Stackrack CA776	151.00
CA697	Base for Stackrack CA778	156.00
CA700	Base for Stackrack CA779	160.00
<b>3-BIN WIDE</b>		
CD449	Base for Stackrack CA774	143.00
CA689	Base for Stackrack CA775	155.00
CA704	Base for Stackrack CA780	162.00
CA694	Base for Stackrack CA776	169.00

## PRE-ENGINEERED BIN COMBINATIONS

### 17-COMPARTMENT SYSTEM INCLUDES:

- 1 row of CA770 bins (2 wide)
- 3 rows of CA768 bins (3 wide)
- 2 rows of CA767 bins (3 wide)
- All corresponding Stackracks®, adapter covers-which allow bins to stack and 12" base

Model No. CD378  
Price/Each \$1918.00

### 31-COMPARTMENT SYSTEM INCLUDES:

- 1 row of CA770 bins (4 wide)
- 1 row of CA769 bins (5 wide)
- 1 row of CA768 bins (6 wide)
- 1 row of CA767 bins (7 wide)
- 1 row of CA766 bins (9 wide)
- All corresponding Stackracks®, adapter covers-which allow bins to stack and 12" base

Model No. CD379  
Price/Each \$4124.00

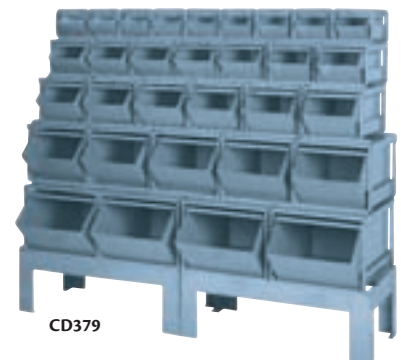

CD379

## STACKBIN

OFFICE PRODUCTS

INSTRUMENTS, SCALES & ELECTRICAL

SHIPPING & PACKAGING

TOOLS & EQUIPMENT

WELDING & METALWORKING

SAFETY EQUIPMENT & SUPPLIES

JANITORIAL & MAINTENANCE

MATERIAL HANDLING & STORAGE



# SMALL PARTS STORAGE

## INDUSTRIAL DRAWER CABINETS

- Provide a rugged modular storage system for small parts
- Select from a range of drawer capacities from 9 to 96 drawers per cabinet
- Various drawer sizes are available including drawer heights of 2 3/4" and 3 1/2", and drawer depths of 11 1/8" and 17"
- Each drawer includes 2 adjustable dividers and full width handles
- Drawer sides are slotted to hold dividers



A. Drawer Cabinets, Base included



B. 18-Drawer Cabinets



C. 24-Drawer Cabinets



D. 9-Drawer Cabinets



E. 30-Drawer Cabinets

**DURHAM MFG®**  
Est. 1922



Type	Model No.	No. of Drawers	Drawer Size				Cabinet Height"	Wt. lbs.	Price /Each	Replacement Drawers	Price /Each	
			W"	x	D"	x						H"
A	FI356	30	5 3/8	x	11 1/4	x	3 1/2	26 7/8	107	946.00	CD661	16.70
A	CA936	48	5 3/8	x	11 1/8	x	2 3/4	33 3/4	176	940.00	CA921	6.22
A	FI357	60	5 3/8	x	11 1/4	x	3 1/2	48	194	1419.00	CD661	16.70
A	CA939	72	5 3/8	x	11 1/8	x	2 3/4	48 1/8	238	1193.00	CA921	6.22
A	FI358	90	5 3/8	x	11 1/4	x	3 1/2	69 1/8	281	1891.00	CD661	16.70
A	CA941	96	5 3/8	x	11 1/8	x	2 3/4	62 1/2	300	1433.00	CA921	6.22
B	CA924	18	5 3/8	x	11 1/4	x	2 3/4	10 7/8	50	236.00	CA921	6.22
B	CA925	18	5 3/8	x	11 1/4	x	3 1/2	12 7/8	87	268.00	CD661	16.70
B	CA926	18	5 3/8	x	17	x	3 1/2	12 7/8	75	363.00	CA923	26.30
C	CA930	24	5 3/8	x	11 1/4	x	2 3/4	14 3/8	60	283.00	CA921	6.22
C	CA932	24	5 3/8	x	17	x	3 1/2	17	96	471.00	CA923	26.30
D	CA942	9	5 3/8	x	11 1/4	x	2 3/4	10 7/8	28	145.00	CA921	6.22
E	CA934	30	5 3/8	x	11 1/4	x	3 1/2	21 1/8	87	475.00	CD661	16.70
E	CA935	30	5 3/8	x	17	x	3 1/2	21 1/8	118	588.00	CA923	26.30
-	CA946		Extra Divider for 2 3/4" H Drawer					0.1	1.23	-	-	
-	CA947		Extra Divider for 3 1/2" H Drawer					0.1	1.30	-	-	

## HEAVY-DUTY 2-SIDED MOBILE CARTS/WORK STATIONS

- Two rigid and two swivel casters with locking brakes
- Sturdy tubular handle allows ease of mobility
- Rubber tray mat provides safe, secure, non-skid work surface
- Finished in rust and acid resistant grey powder coat
- Heavy-duty casters, capacity of 1000 lbs.
- Shipped fully welded

**DURHAM MFG®**  
Est. 1922



- Two 12-compartment bins back-to-back
- Overall dimensions: 34" W x 24" D x 32" H
- Ship weight: 139 lbs.

Model No. CD330  
Price/Each \$857.00



- Two 40-compartment bins back-to-back
- Overall dimensions: 34" W x 24" D x 32" H
- Ship weight: 159 lbs.

Model No. CD349  
Price/Each \$873.00



Front



Back

- One lockable 4-compartment storage cabinet
- One storage bin with 12 compartments
- 12 easily dividable pull out storage drawers, six on each side
- Overall dimensions: 34" W x 24" D x 36" H
- Ship weight: 180 lbs.

Model No. MO070  
Price/Each \$1059.00

## STEEL STORAGE BINS

- Pigeonhole type steel storage bin units organise small parts
- Best suited where space is limited and organization is crucial
- Produced of prime cold rolled steel
- Fully welded, will not warp, twist or sag
- Fully hemmed label holders provide adequate space for content identification
- Each divider is hemmed in a tear drop design to avoid sharp edges
- Doors with padlock attachment and bases to raise units are available with most models
- All units are 33 3/4" wide and are available in depths of 12" or 8 1/2"
- 12" deep units feature a 45° slope front for easy removal of parts
- Finished in grey powder coat

**DURHAM MFG<sup>®</sup>**  
Est. 1922

Perfect for organising your shop - can be filled with just about anything!



CA151



CA152



CA154

Base for storage bins

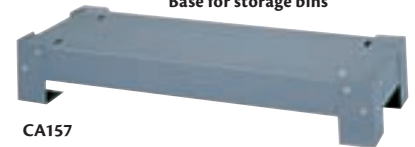

CA157

Door for storage bins



CA142



CA136



CA133



CA149

Model No.	Dimensions				No. of Bins	Bin Dimensions				Wt. lbs.	Price /Each	Base Model No.	Price /Each	Door Model No.	Price /Each		
	W"	x	D"	x	H"	W"	x	D"	x	H"							
<b>12" DEEP STORAGE BINS</b>																	
CA133	33 3/4	x	12	x	11 1/2	16	4	x	11 7/8	x	5 1/8	25	148.00	CA157	74.90	-	-
CA134	33 3/4	x	12	x	19 1/4	18	5 3/8	x	11 7/8	x	6 3/8	38	216.00	CA157	74.90	-	-
CA136	33 3/4	x	12	x	23 7/8	24	5 3/8	x	11 7/8	x	5 1/2	44	223.00	CA157	74.90	CA142	78.30
CA149	33 3/4	x	12	x	23 7/8	40	4	x	11 7/8	x	4 1/2	50	244.00	CA157	74.90	CA142	78.30
CA151	33 3/4	x	12	x	42	42	5 3/8	x	11 7/8	x	5 1/2	71	353.00	CA157	74.90	CA141	114.00
CA152	33 3/4	x	12	x	42	56	4 7/8	x	11 7/8	x	5 1/8	75	377.00	CA157	74.90	CA141	114.00
CA154	33 3/4	x	12	x	42	72	4	x	11 7/8	x	4 1/2	80	380.00	CA157	74.90	CA141	114.00
<b>8 1/2" DEEP STORAGE BINS</b>																	
CA150	33 3/4	x	8 1/2	x	22 1/4	40	4	x	8 3/8	x	4 1/2	50	222.00	CA158	91.80	-	-
CA155	33 3/4	x	8 1/2	x	42	72	4	x	8 3/8	x	4 1/2	85	354.00	CA158	91.80	CA141	114.00

# BULK CONTAINERS

## BULK STACKING CONTAINERS

- Heavy-duty all-welded construction
- Mesh containers use 2" x 2" x 10 gauge wire mesh
- All containers use a 13-gauge corrugated sheet steel base
- 2" x 2" x 3/16" angle posts
- 4-way fork truck entry with 4" under-clearance
- Available with one drop gate or fully enclosed sides
- Height: 24" inside, 30" overall
- Stackable up to 5 high
- Other sizes are available
- Painted durable Kleton blue



CF449



CF453



CF457



CF450



Model No.	Mfg. No.	Description	Capacity lbs.	Width"	Length"	Weight lbs.	Price /Each
<b>MESH CONTAINERS</b>							
CF449	KSMC-3440-0	Fully Enclosed	3000	34.5	40.5	125	355.00
CF450	KSMC-3440-1	One Drop Gate	3000	34.5	40.5	130	423.00
CF451	KSMC-4048-0	Fully Enclosed	3000	40.5	48.5	150	409.00
CF452	KSMC-4048-1	One Drop Gate	3000	40.5	48.5	160	479.00
<b>SHEET CONTAINERS</b>							
CF453	KSSC-3440-0	Fully Enclosed	3500	34.5	40.5	150	539.00
CF454	KSSC-3440-1	One Drop Gate	3500	34.5	40.5	150	620.00
CF455	KSSC-4048-0	Fully Enclosed	3500	40.5	48.5	185	629.00
CF456	KSSC-4048-1	One Drop Gate	3500	40.5	48.5	185	699.00
<b>CORRUGATED CONTAINERS</b>							
CF457	KSCC-3440-0	Fully Enclosed	4500	34.5	40.5	160	552.00
CF458	KSCC-3440-1	One Drop Gate	4500	34.5	40.5	160	655.00
CF459	KSCC-4048-0	Fully Enclosed	4500	40.5	48.5	195	699.00
CF460	KSCC-4048-1	One Drop Gate	4500	40.5	48.5	195	790.00

## OPEN MESH CONTAINERS

- Rugged construction ensures long lasting, trouble free service
- 3/4" - 13 gauge expanded metal mesh panels
- 2 half drop gates
- Four-way fork truck access
- 4 1/4" underclearance
- Overall dimensions: 34 1/2" x 40 1/2" x 32 1/4"
- Stackable up to 5 high
- 15 cu.ft. capacity
- Deck capacity: 2500 lbs. mesh deck, 3000 lbs. sheet metal deck
- Blue enamel finish

Model No.	Style	Wt. lbs.	Price /Each
CA397	Mesh deck	105	239.00
CA398	Sheet metal deck	114	251.00
CA368	Replacement foot	0.72	2.86



## COLLAPSIBLE WIRE CONTAINERS

- Welded, square mesh wire allows full visibility and excellent ventilation
- Foldable and constructed of durable 3-gauge wire
- 4-way entry for easy use with lift trucks
- Convenient drop gate design for easy access to products
- Safety rating plates with static load capacity and static load height
- Stack up to 4 high
- 4" under clearance

Model No.	Mfg. No.	Weight Cap. Lbs.	Dimensions* W x D x H	Usable Height**	Drop Gate	Wt. Lbs.	Mesh Size"	Price /Each
CF462	JR1	1,000	20 x 32 x 21	16	32" side	43	1x1	205.00
CF463	JR5	1,000	20 x 32 x 21	16	32" side	55	1/2 x 1/2	245.00
CF464	C324048S4	4,000	32 x 40 x 34	28	40" side	122	2 x 2	355.00
CF465	C404824S4	4,000	40 x 48 x 30	24	48" side	150	2 x 2	425.00
CF466	C404830S4	4,000	40 x 48 x 36	30	48" side	163	2 x 2	465.00
CF467	C404830E4	4,000	40 x 48 x 36	30	40" end	163	2 x 2	592.00
CF468	C404836S4	4,000	40 x 48 x 42	36	48" side	176	2 x 2	497.00



Shows 2 units stacked



CF468



## THREADED ROD RACKS

- Eighteen 2 1/8" dia. openings
- Overall dimensions: 24 1/8" W x 6 7/8" D x 24" H
- Weight: 16 lbs.
- Powder coat grey finish
- Shipped knocked down

Model No. CB578  
Price/Each \$112.00

**DURHAM MFG**  
Est. 1922



## MULTI-PURPOSE BINS

- Removable vertical dividers allow creation of multi-width compartments
- Scoop shelves allow contents to be removed easily
- Keyhole slots provide for wall mounting
- 36 bins (3 7/8" W x 4 5/8" D x 3 3/4" H)
- 23 3/4" W x 4 3/4" D x 23 3/4" H
- Weight: 25 lbs.
- Powder coat grey finish

Model No. CA161  
Price/Each \$157.00

**DURHAM MFG**  
Est. 1922



## MEDIUM-DUTY COLLAPSIBLE BULKPAK CONTAINERS

- Sturdy and quick to erect or knock down, fully recyclable Orbis containers replace tons of corrugated paper and wood packaging waste
- They can be collapsed to one-third their height for space-saving return shipment
- They stack safely, full or folded to create warehouse space without racking
- Weight capacity: 1500 lbs.
- Colour: Black (CF492 is blue)

**ORBIS**



### COVERS

	Model No.	Price/Each
A	CF493	175.00
B	CF489	158.00
C	CF486	137.00

Model No.	Description	Ext. Dimensions L" x W" x H"	Cap. Cu. Ft.	Wt. lbs.	Covers	Price /Each
CF490	Collapsible Container, 2 Drop Gate	48 x 45 x 25	19.3	115	A	720.00
CF491	Collapsible Container, 2 Drop Gate	48 x 45 x 34	28.5	140	A	752.00
CF492	Collapsible Container, 2 Drop Gate, Blue	48 x 45 x 34	28.5	140	A	966.00
CF487	Collapsible Container, 2 Drop Gate	48 x 40 x 34	27.9	150	B	764.00
CF488	Collapsible Container, 2 Drop Gate	48 x 40 x 39	32.8	160	B	794.00
CF483	Collapsible Container, 2 Drop Gate	30 x 32 x 25	8.4	60	C	511.00
CF484	Collapsible Container, 2 Drop Gate	30 x 32 x 34	12.5	80	C	567.00

Prices F.O.B. Mississauga, Ont.

## COLLAPSIBLE STRUCTURAL POLYETHYLENE CONTAINERS

Sturdy, long-lived and quick to erect or knock down, fully recyclable Orbis containers replace tons of corrugated paper and wood packaging waste. With as many as four sidewall heights, these space-efficient collapsibles cube out trailers and ISO containers. They can be collapsed to one-third their height for space-saving return shipment. And they stack safely, full or folded to create warehouse space without racking. **Models featured below include standard 2 drop gates (1 drop and no drop also available per special request). Models below have a 2000 lbs. capacity and 4-way entry. They can be used with pallet trucks and forklifts.**



### COVERS

	Model No.	Price/Each
A	CC169	166.00
B	CC170	188.00
C	CC171	195.00

**ORBIS**

Model No.	Description	Ext. Dimensions L" x W" x H"	Cap. Cu. Ft.	Wt. lbs.	Covers	Price /Each
CF447	Collapsible Container, 2 drop gate	48 x 45 x 25	19.7	115	C	753.00
CF448	Collapsible Container, 2 drop gate	48 x 45 x 34	29.4	140	C	841.00
CF445	Collapsible Container, 2 drop gate	48 x 40 x 34	24.9	150	B	888.00
CF446	Collapsible Container, 2 drop gate	48 x 40 x 39	29.8	160	B	930.00
CF443	Collapsible Container, 2 drop gate	30 x 32 x 25	8.7	60	A	586.00
CF444	Collapsible Container, 2 drop gate	30 x 32 x 34	12.9	80	A	626.00

Prices F.O.B. Mississauga, Ont.

## MATERIAL HANDLING BASKET

- All welded 3/16" steel material basket
- Can be moved by pallet trucks and by overhead lifts
- Dimensions: 48" L x 48" W x 24" H
- Fork pocket size: 3.5" x 7.5"
- Outside distance between fork pockets: 27"
- Thickness of steel: 3/16"
- Diameter of lifting eyes: 1-1/16"
- Customizable dimensions and capacities available

F.O.B. Vaudreuil, Qc

**MuscleMate**

Model No.	Capacity lbs.	Price /Each
MN664	1000	2662.00
MN665	2000	3412.00
MN666	4000	3917.00



# PALLETS

## LIGHT DUTY EXPORT PALLETS

- Low cost lightweight alternative to wood pallets.
- Made of 100% recycled plastics and completely recyclable
- These low cost, single use pallets are designed for export oriented companies.
- Pallets are nestable for easy storing and space saving.
- 4-way entry for both forklift and pallet truck
- Streamlines customs process and reduces shipping delays
- ISPM 15 exempt

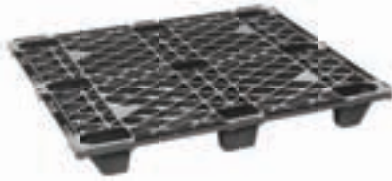

Model No.	Dimensions				Capacity lbs.		Wt. lbs.	Price /Each	
	L"	x	W"	x	Static	Dynamic			
MN457	40	x	48	x	5.2	3500	1500	12.5	45.00

## NESTABLE EXPORT PALLET

- Economic, environmental and efficient alternative to wood pallets
- 100% recyclable export pallet
- Low cost lightweight pallet ideal for export and one way shipments
- Flow thru design allows for easy cleaning
- Pallet Entry: 4-Way
- ISPM 15 exempt



**ORBIS**

Model No.	Dimensions				Capacity lbs.		Wt. lbs.	Price /Each	
	L"	x	W"	x	Static	Dynamic			
MN725	48.2	x	40.2	x	5.75	15 000	2000	23.2	62.00

## NESTABLE LIGHTWEIGHT PALLETS WITH LIP

- 5/8" raised edge surrounding the deck prevents loads from sliding off
- Single faced, one-piece high-density polyethylene construction
- Cleans easily with efficient drainage design
- Nestable
- 4-way fork lift and 2-way pallet truck entry
- ISPM 15 exempt

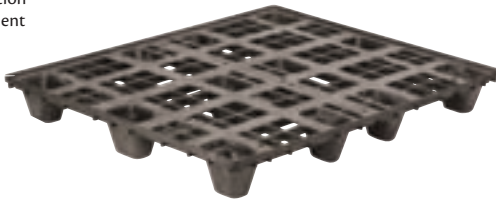

**ORBIS**

Model No.	Dimensions				Capacity lbs.		Wt. lbs.	Price /Each	
	L"	x	W"	x	Static	Dynamic			
CB521	48	x	40	x	5 1/2	10 000	2500	21	142.00

Also available in USDA/FDA approved material for non-direct food contact.

## NESTABLE SINGLE-FACED PALLETS

- One piece structural foam pallets are lightweight, nestable and recyclable
- High density polyethylene construction
- Large rectangular legs make it an excellent choice for most conveyor systems
- Stacks 15 high in only 48" for cost effective transport
- Fork lift: 4-ways
- Pallet truck: 4-ways
- Colour: Black
- ISPM 15 exempt

**ORBIS**



Model No.	Dimensions				Capacity lbs.		Wt. lbs.	Price /Each	
	L"	x	W"	x	Static	Dynamic			
CB524	48	x	48	x	5 3/4	30 000	4000	45.5	251.00

## PLASTIC PALLETS

**VALLEYCRAFT**  
ALL ABOUT WORK

Sturdy, lightweight pallets with rigid centre supports offer versatile, damage-free storage and movement for a wide range of materials. Suitable for the handling of all materials in paper, plastic or burlap bags; as well as tires, construction materials and items under assembly.

- Injection-molded plastic is easy to clean and resistant to both chemicals and weather
- Nestable (each adds only 5/8" to the height of a stack)
- 1 1/2" deep stringers can also be handled by a standard forklift
- ISPM 15 exempt

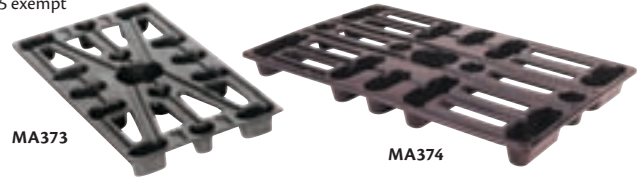

Model No.	Deck Size L" x W"	Stringer Height"	Construction	Capacity lbs.		Wt. lbs.	Price /Each
				Static	Dynamic		
MA373	24 x 12	1 1/2	Black Plastic	800		1	7.63
MA374	24 x 15	1 1/2	Black Plastic	800		1 1/4	11.00

## STACK'R LD PALLETS

**ORBIS**

- Open deck with stringer
- Designed specifically for stacking applications
- Made of 100% recycled content
- Lower per-trip cost than alternative pallets
- Versatile handling with 4-way hand and fork truck entry
- Lighter weight for better ergonomics
- ISPM 15 exempt



Model No.	Dimensions				Capacity lbs.		Wt. lbs.	Price /Each	
	L"	x	W"	x	Static	Dynamic			
MN714	48	x	40	x	5.9	30 000	4000	44.4	186.00

## SMOOTH-DECK NESTABLE PALLETS

- Manufactured in HDPE Structural Foam
- Empty pallets nest for a cost-efficient return trip or warehouse storage.
- Lightweight and easy to manually handle, with no nails, splinters or broken boards to risk employee injury
- 4-way entry using both Fork Truck or Hand Trucks
- An economic and environmental alternative to wood pallets or skids.
- Exempt from ISPM 15



**ORBIS**

Model No.	Dimensions				Capacity lbs.		Wt. lbs.	Price /Each	
	L"	x	W"	x	Static	Dynamic			
MN171	48	x	40	x	6	30 000	4000	37	165.00

## RETAIL DISPLAY PALLETS

- Modular
- This pallet offers marketers an attractive display solution with efficient material handling
- Easily creates in-aisle or end-of-aisle displays
- The flat, smooth surface allows for easy set up in a warehouse or co-packing facility
- Can be moved directly to sales floor to reduce labor costs and maximize storage space
- Decreases safety liabilities and product shrink by eliminating sharp edges, splinters and nails found in wood alternatives
- Pallet Entry: 4-Way
- ISPM 15 exempt

**ORBIS**



Model No.	Dimensions				Capacity lbs.		Wt. lbs.	Price /Each	
	L"	x	W"	x	Static	Dynamic			
MN709	24	x	24	x	5.5	8000	1000	9	42.30
MN713	48	x	24	x	5.5	15 000	2000	19	79.20
MN710	48	x	48	x	5.5	20 000	4000	38	146.00
MN712	48	x	40	x	5.5	30 000	4000	39.3	166.00

## ONE PIECE RACKABLE PALLETS

- Ideal for use in food industry and in situations where higher capacity racking capabilities are important
- Double-deck, one piece construction with an open grid and large corner for easy cleaning
- Standard high density polyethylene or FDA compliant HDPE virgin material for direct food contact
- In an edge-supported rack, pallet can hold up to a 2000 lbs. evenly distributed load
- 4 way fork lift or pallet truck entry
- Colour: Standard-Black, FDA compliant material-Blue
- ISPM 15 exempt

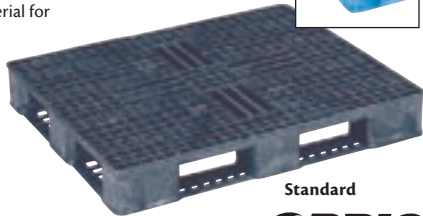

FDA Compliant Material

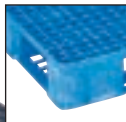

Standard

**ORBIS**

Model No.	Dimensions L" x W" x H"	Description	Capacity lbs.		Wt. lbs.	Price /Each
			Static	Dynamic		
CB536	48 x 40 x 6 5/8	Standard	30 000	5000	45	313.00
CB537	48 x 40 x 6 5/8	USDA/FDA	30 000	5000	45	321.00

Note: Test for pallet deflection on loads over 2000 lbs. when used with unsupported (edge-supported) pallet rack.

## STACK'R MD PALLETS

- Open Deck With Stringer
- Designed specifically for stacking and racking applications
- Made of 100% HDPE
- The smooth, non-porous construction protects product and does not absorb moisture or odor
- Pallet Entry: 4-Way
- ISPM 15 exempt



**ORBIS**

Model No.	Dimensions L" x W" x H"	Capacity lbs.		Wt. lbs.	Price /Each
		Static	Dynamic		
MN726	48 x 40 x 5.9	30 000	4000	44.4	269.00

## DOUBLE DECK STACKABLE PALLETS

- Designed for handling and shipping heavy products
- Manufactured in HDPE structural foam
- An economic, environmental and efficient alternative to wood pallets or skids
- Double deck design, ideal for stack loading, conveying systems, distribution and static storage
- 4-way entry for fork and hand trucks
- ISPM 15 exempt

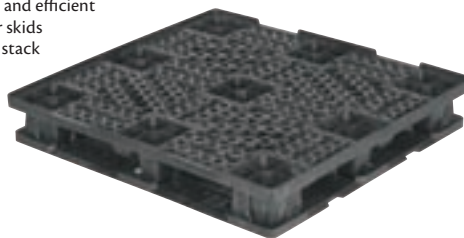

**ORBIS**

Model No.	Dimensions L" x W" x H"	Capacity lbs.		Wt. lbs.	Price /Each
		Static	Dynamic		
MN168	48.7 x 45.7 x 7.5	30 000	4000	62	399.00

## MEDIUM-DUTY FOOD GRADE PALLETS

- Typically used in the food industry
- 1-piece construction with an open grid for easy cleaning
- Made of FDA compliant HDPE virgin material for direct food contact
- Edge-supported pallet on a rack can hold up to a 2200-lb evenly distributed load
- 4-way fork lift or pallet truck entry
- ISPM 15 exempt



Model No.	Dimensions L" x W" x H"	Capacity lbs.		Wt. lbs.	Price /Each
		Static	Dynamic		
MN490	48 x 40 x 6 5/8	25 000	5000	35	171.00

## RACKSTAR II™ PALLET

- Highly impact resistant design
- Internal reinforcements meet aggressive application requirements
- 100% recyclable with fully removable reinforcement structure
- Solid wall design for increased durability
- 4-way forklift accessible
- Easy to sanitize
- Removable/repairable stringers or full frame bottom, with easy-to-replace fasteners, are available for added capacity in forklift and conveyor use
- Perimeter molded-in lip options offer secure product loading and stacking
- Rackable
- ISPM 15 exempt

Rackstar II™ Pallet

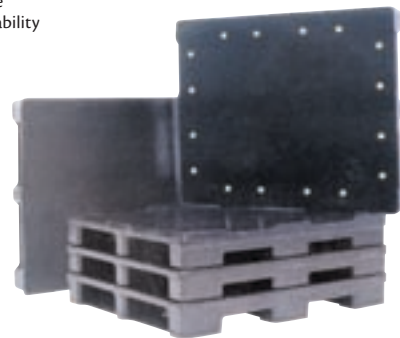

**ORBIS**

Model No.	Dimensions L" x W"	Description	Capacity lbs.		Capacity lbs.			Wt. lbs.	Price /Each
			Static	Dynamic	Decking	Centre Supports	Edge Supported		
CC163	48 x 40 x 6"	without lip (includes 16 deck grommets)	30 000	6000	6000	6000	3000	56.6	377.00

## EXTRA-LONG STACKABLE PALLETS

- Pallet is fully reversible for double stacking of loads
- Manufactured in HDPE structural foam
- Designed for handling and shipping heavy product loads
- Ideal for stack loading, conveying systems, distribution and static storage
- 4-way entry for fork trucks
- ISPM 15 exempt



**ORBIS**

Model No.	Dimensions L" x W" x H"	Capacity lbs.		Wt. lbs.	Price /Each
		Static	Dynamic		
MN170	72 x 48 x 5.8	30 000	4000	110	619.00

## MEDIUM-DUTY RACKABLE PLASTIC PALLETS

- Unique rib design for easy cleaning and sanitary applications
- Edge-supported racking application, maximum capacity of 1400 lbs.
- Bottom design of pallet ideal for automated conveying
- Anti-skid grommets on both top and bottom
- High pressure injection molded plastic pallets made with recyclable materials
- Grey
- ISPM 15 exempt

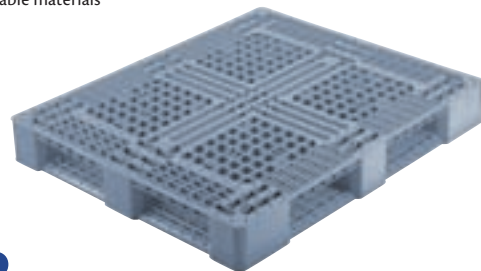

**MONOFLO**  
INTERNATIONAL, INC.

Model No.	Dimensions L" x W" x H"	Capacity lbs.		Wt. lbs.	Price /Each
		Static	Dynamic		
MN172	48 x 40 x 6	30 000	3000	42	218.00



# PALLETS

## ALUMINUM PALLETS

- Welded aluminum construction provides superb weight-to-load ratio
- Ideal for heavy industrial, food, electronics, telecommunications, pharmaceuticals and consumer goods
- Long service life indoors and outdoors, lightweight and low maintenance
- Resists fire, freezing temperatures, chemicals, rust and insects
- Always looks clean, easy to wash and sterilize
- Works seamlessly with automated and mechanized material handling equipment
- 2-way fork entry, ridged deck boards provide grip to reduce load shifting
- ISPM 15 exempt

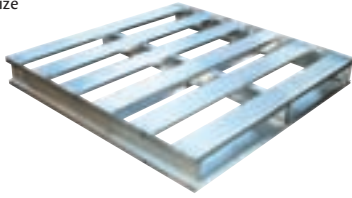

Model No.	Dimensions				Capacity lbs.		Wt. lbs.	Price /Each	
	L"	x	W"	x	H"	Static			Dynamic
CF416	48	x	42	x	6	6000	4000	40	604.00
CF417	48	x	48	x	6	6000	4000	50	629.00

## PALLET NO STACK® CONES

- Prevent damage to your shipment with No Stack® signs - warns against double stacking your shipment, ensuring your shipment remains on top
- 3 dimensional anti-stack warning devices, that easily crushes if stacked on, proof that your shipment was mishandled
- Strap easily to the top of your pallet, or attach with packaging tape
- 100/package



Model No. PC616  
Price/Each \$348.00

## LABEL HOLDERS

- Clearly identify your shelf/bin contents with the efficient and time-saving Aigner holders
- Versatile, highly protective, easy to read, and even custom designed with a special matte finish making bar code applications easy
- Ideal for all types of racking, shelving and bin/drawer storage systems
- Labels provided
- Sold in packages of 12



### HOL-DEX®

- Can be custom cut to your specific size specifications
- Colour: Clear



Model No.	Dim. W" x L"	Price /Package
<b>SELF-ADHESIVE</b>		
OA340	1/2 x 6	18.80
OA339	3/4 x 6	21.00
OA341	1 x 6	23.95
OA338	2 x 6	32.30
<b>MAGNETIC</b>		
RG650	1/2 x 6	20.30
OA389	3/4 x 6	22.50
OA336	1 x 6	26.30
<b>HOOK &amp; LOOP</b>		
RG660	1 x 6	33.80
RG665	2 x 6	55.60

### SUPERSCAN®

- Available in 4 extra large sizes for pallet racking installation
- Clear plastic matte finish assures precise bar code reading everytime
- Inserts are laser ink jet printer compatible for easy labeling
- Colour: Clear



### SUPERSCAN® (CLEAR ONLY)

Model No.	Dimensions W" x L"	Qty /Box	Price /Box
<b>SELF-ADHESIVE</b>			
OG356	2 x 3.5	50	39.80
RG670	3 x 5	50	48.10
RG671	4 x 6	50	56.30
RG681	5 x 7	25	49.60

Model No.	Dimensions W" x L"	Qty /Box	Price /Box
<b>MAGNETIC</b>			
OG357	2 x 3.5	50	63.80
RG672	3 x 5	50	66.10
RG673	4 x 6	50	82.60
RG683	5 x 7	25	63.80

## ROLL PALLETS

- Rotationally molded of durable polyethylene
- Lightweight pallets handle rolls up to a maximum diameter of 42"
- Molded construction eliminates product damage due to splinters and nails
- 2-way forklift entry
- ISPM 15 exempt



Model No.	Dimensions				Capacity lbs.	Wt. lbs.	Price /Each	
	L"	x	W"	x				H"
CB535	21	x	38 1/2	x	8 1/2	1500	24	134.00

## DRUM PALLETS

The 48" x 48" one-piece drum pallet features four molded-in rings to secure the drums during transportation, underside rings for secure double stacking and complete flow through design.

- Structural foam
- Pallets fit side by side in regular trailers
- Standard colour: Black
- Fork truck entry: 4-ways
- Hand truck entry: 4-ways
- ISPM 15 exempt



Model No.	Dimensions			Capacity lbs.		Wt. lbs.	Price /Each		
	L"	x	W"	x	H"			Static	Dynamic
CC153	48.8	x	48.8	x	5.5	30 000	4000	42	456.00

## EDGEBOARD CORNER PROTECTORS

Improves stocking strength and cushions package edges against hard knocks.

Also helps improve the flow of strapping and stretch film around the product.

20/package.

Pallet quantities are available. Other thicknesses & lengths available upon request.

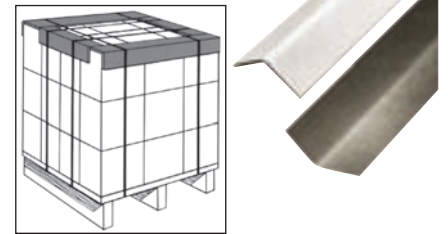

## PRE-BUNDLED PACKS

Model No.	Leg"	Thickness"	Length"	Price /Each
PB264	2.5 x 2.5	0.200	36	24.30
PB265	2.5 x 2.5	0.200	42	28.30
PB266	2.5 x 2.5	0.200	48	32.40
PB267	3 x 3	0.200	36	26.70
PB268	3 x 3	0.200	42	31.10
PB269	3 x 3	0.200	48	35.60

## SLIP 'N STICK™ AISLE SIGNS

- Create your own customised warehouse signs
- Built-in flexible hinge prevents breakage
- Included: 10 sign holders (11" x 8 1/2"), 12 yellow laser/ink jet sheets and instructions



### SNAP-ON

- Snaps into pallet rack assembly holes, can snap out to relocate

Model No. OE798  
Price/Each \$46.60

### SELF-ADHESIVE

- Adheres to flat surfaces, for more permanent applications

Model No. OJ943  
Price/Each \$46.60

## PALLET RACKING SYSTEMS

### MOST COMMON PALLET RACKING COMPONENTS

- Provides the widest range of flexibility for pallet and bulk storage needs with excellent storage density
- Stocking vertically and horizontally maximizes available space with the ability to access each individual load
- Installs quickly without special tools and adjust easily to your specific needs
- Typical applications include: warehouses, distribution centres and manufacturing plants
- Only two basic components are required: beams and frames

**Note:** Pallet racking products are FOB the manufacturer.



Box Beam



Step Beam



Upright End Frames

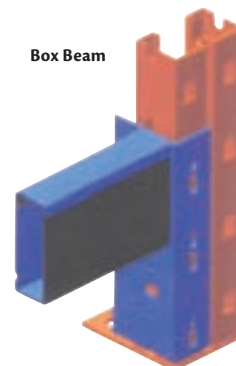

Box Beam

## CENTENNIAL PROFILES\*

### UPRIGHT END FRAMES

Priced per Each

Model No.	Dimensions D" x H"	Wt. Cap. lbs.	Price /Each
RB819	42 x 96	20 000	107.00
RB747	42 x 120	20 000	127.00
RB763	42 x 144	20 000	156.00
RB779	42 x 168	20 000	183.00
RB795	42 x 192	20 000	206.00

### STEP BEAMS

Priced per Pair

Model No.	Dimensions H" x L"	Wt. Cap. Pair/lbs.	Price /Pair
RB491	4 x 96	6804	129.00
RB465	4 x 108	5652	145.00
RB469	4 x 120	4578	160.00
RB517	4 1/2 x 96	8039	138.00
RB495	4 1/2 x 108	7106	153.00
RB499	4 1/2 x 144	6140	169.00

### BOX BEAMS

Priced per Pair

Model No.	Dimensions H" x L"	Wt. Cap. Pair/lbs.	Price /Pair
RB275	4 x 96	6886	128.00
RB263	4 x 108	5775	139.00
RB269	4 x 144	3249	178.00
RB288	4 1/2 x 96	8105	134.00
RB277	4 1/2 x 108	7204	148.00
RB283	4 1/2 x 144	4310	190.00

\*See page 50 for complete listing of sizes

## REDIRACK PROFILES\*\*

### UPRIGHT END FRAMES

Priced per Each

Model No.	Dimensions D" x H"	Wt. Cap. lbs.	Price /Each
RL022	42 x 144	25 000	200.00
RL023	42 x 168	25 000	230.00
RL024	42 x 192	25 000	271.00
RL025	42 x 216	25 000	304.00

### STEP BEAMS

Priced per Each

Model No.	Dimensions H" x L"	Wt. Cap. Pair/lbs.	Price /Each
RL026	4 x 96	5400	66.80
RL903	4 1/2 x 96	6470	71.40
RL904	4 x 102	5000	71.10
RL905	4 x 108	4480	75.60
RL027	4 1/2 x 108	5750	80.90
RL906	6 x 144	6390	123.00

### BOX BEAMS

Priced per Each

Model No.	Dimensions H" x L"	Wt. Cap. Pair/lbs.	Price /Each
RL032	4 x 96	7010	77.50
RL033	4 x 108	6080	85.70
RL902	6 x 144	5230	133.00

\*\* Redirack uprights and beams are standard in orange, blue available upon request.

Other dimensions available.

Call your Material Handling Specialist today!

# RACKING/SHELVING

## CENTENIAL UPRIGHTS & STRINGERS

Make every inch of your storage space count by combining standard sized uprights and stringers (box type or recessed type) to create a racking system that is customized to your needs.

- Feature a 50 k.s.i. minimum yield to achieve higher load capacities
- Centennial blue
- All racking is FOB Concord, Ontario

Contact our sales department for further technical assistance.



### MEDIUM DUTY UPRIGHTS 20000-LB. CAPACITY

Depth	24"	30"	36"	42"	48"	60"
6'	RB798	RB800	RB802	RB803	RB804	RB805
7'	RB806	RB808	RB810	RB811	RB812	RB813
8'	RB814	RB816	RB818	RB819	RB820	RB821
9'	RB822	RB824	RB826	RB827	RB828	RB829
10'	RB742	RB744	RB746	RB747	RB748	RB749
11'	RB750	RB752	RB754	RB755	RB756	RB757
12'	RB758	RB760	RB762	RB763	RB764	RB765
13'	RB766	RB768	RB770	RB771	RB772	RB773
14'	RB774	RB776	RB778	RB779	RB780	RB781
15'	RB782	RB784	RB786	RB787	RB788	RB789
16'	RB790	RB792	RB794	RB795	RB796	RB797

### HEAVY-DUTY UPRIGHTS 27000-LB. CAPACITY

Depth	24"	30"	36"	42"	48"	60"
6'	RB714	RB715	RB716	RB717	RB718	RB719
7'	RB720	RB721	RB722	RB723	RB724	RB725
8'	RB726	RB728	RB730	RB731	RB732	RB733
9'	RB734	RB736	RB738	RB739	RB740	RB741
10'	RB608	RB610	RB612	RB613	RB614	RB615
11'	RB616	RB618	RB620	RB621	RB622	RB623
12'	RB624	RB626	RB628	RB629	RB630	RB631
13'	RB632	RB634	RB636	RB637	RB638	RB639
14'	RB640	RB642	RB644	RB645	RB646	RB647
15'	RB648	RB650	RB652	RB653	RB654	RB655
16'	RB656	RB658	RB660	RB661	RB662	RB663
18'	RB664	RB666	RB668	RB669	RB670	RB671
20'	RB672	RB674	RB676	RB677	RB678	RB679
22'	RB680	RB682	RB684	RB685	RB686	RB687
24'	RB688	RB690	RB692	RB693	RB694	RB695
26'	RB696	RB697	RB698	RB699	RB700	RB701
28'	RB702	RB703	RB704	RB705	RB706	RB707
30'	RB708	RB709	RB710	RB711	RB712	RB713

Box Type Stringer

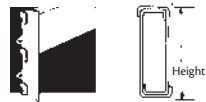

Recessed Type Stringer

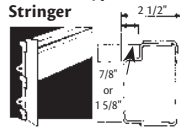

### BOX TYPE STRINGERS CAP. LBS. PER PAIR

LGTH	48"		54"		60"		66"		72"		78"		84"		90"		96"		102"		108"		114"		120"		126"		132"		138"		144"	
Height	Model No.	Cap. lbs.	Model No.	Cap. lbs.	Model No.	Cap. lbs.	Model No.	Cap. lbs.	Model No.	Cap. lbs.	Model No.	Cap. lbs.	Model No.	Cap. lbs.	Model No.	Cap. lbs.	Model No.	Cap. lbs.	Model No.	Cap. lbs.	Model No.	Cap. lbs.	Model No.	Cap. lbs.	Model No.	Cap. lbs.	Model No.	Cap. lbs.	Model No.	Cap. lbs.	Model No.	Cap. lbs.		
2"	RB203	5340	RB204	4385	RB205	3551	RB206	2936	RB207	2466	RB208	2101	RB209	1578	RB210	1812	RB211	1388	RB195	1229	RB196	1096	RB197	984	RB198	888	RB199	805	RB200	733	RB201	671	RB202	616
2 1/2"	RB220	7821	RB221	6952	RB222	6078	RB223	5024	RB224	4221	RB225	3596	RB226	3102	RB227	2702	RB228	2374	RB212	2103	RB213	1876	RB214	1684	RB215	1520	RB216	1378	RB217	1255	RB218	1149	RB219	1055
3"	RB237	9397	RB238	8350	RB239	7518	RB240	6839	RB241	6265	RB242	5630	RB243	4855	RB244	4229	RB245	3716	RB229	3293	RB230	2937	RB231	2636	RB232	2379	RB233	2158	RB234	1966	RB235	1799	RB236	1650
3 1/2"		RB254	10032	RB255	9389	RB256	8536	RB257	7824	RB258	7222	RB259	6706	RB260	6187	RB261	5438	RB246	4817	RB247	4296	RB248	3856	RB249	3481	RB250	3157	RB251	2876	RB252	2632	RB253	2417	
4"				RB270	10016	RB271	9181	RB272	8475	RB273	7870	RB274	7345	RB275	6886	RB262	6476	RB263	5775	RB264	5184	RB265	4670	RB266	4243	RB267	3866	RB268	3538	RB269	3249			
4 1/2"						RB284	10806	RB285	9975	RB286	9262	RB287	8645	RB288	8105	RB276	7628	RB277	7204	RB278	6825	RB279	6507	RB280	5630	RB281	5130	RB282	4694	RB283	4310			
5"								RB297	10727	RB298	10012	RB299	9366	RB289	8834	RB290	8344	RB291	7904	RB292	7509	RB293	7152	RB294	6312	RB295	6050	RB296	5557	RB297	5175	RB298	4815	
5 1/2"										RB300	10100	RB301	9540	RB302	9037	RB303	8585	RB304	8176	RB305	7805	RB306	7466	RB307	6998	RB308	6557	RB309	6130	RB310	5715	RB311	5310	
6"										RB308	10400	RB309	10338	RB310	9794	RB311	9304	RB312	8861	RB313	8458	RB314	8091	RB315	7754	RB316	7430	RB317	7110	RB318	6800	RB319	6500	
6 1/2"																					RB316	10200	RB317	10372	RB318	9901	RB319	9470	RB320	9076	RB321	8700	RB322	8330

### 7/8" RECESSED TYPE STRINGERS CAP. LBS. PER PAIR

LGTH	48"		54"		60"		66"		72"		78"		84"		90"		96"		102"		108"		114"		120"		126"		132"		138"		144"	
Height	Model No.	Cap. lbs.	Model No.	Cap. lbs.	Model No.	Cap. lbs.	Model No.	Cap. lbs.	Model No.	Cap. lbs.	Model No.	Cap. lbs.	Model No.	Cap. lbs.	Model No.	Cap. lbs.	Model No.	Cap. lbs.	Model No.	Cap. lbs.	Model No.	Cap. lbs.	Model No.	Cap. lbs.	Model No.	Cap. lbs.	Model No.	Cap. lbs.	Model No.	Cap. lbs.	Model No.	Cap. lbs.		
2 1/2"	RB379	7143	RB381	6349	RB383	5714	RB385	4800	RB387	4041	RB389	3443	RB391	2970	RB393	2586	RB395	2273	RB363	2014	RB365	1796	RB367	1612	RB369	1455	RB371	1320	RB373	1206	RB375	1100	RB377	1010
3"	RB413	9115	RB415	8102	RB417	7292	RB419	6629	RB421	6077	RB423	5364	RB425	4625	RB427	4030	RB429	3540	RB397	3137	RB399	2798	RB401	2511	RB403	2266	RB405	2055	RB407	1873	RB409	1719	RB411	1574
3 1/2"			RB447	10334	RB449	9310	RB451	8463	RB453	7758	RB455	7161	RB457	6650	RB459	6068	RB461	5333	RB431	4725	RB433	4214	RB435	3782	RB437	3414	RB439	3096	RB441	2821	RB443	2582	RB445	2371
4"				RB479	10886	RB481	9897	RB483	9272	RB485	8374	RB487	7776	RB489	7258	RB491	6804	RB463	6337	RB465	5652	RB467	5072	RB469	4578	RB471	4153	RB473	3783	RB475	3462	RB477	3179	
4 1/2"						RB509	10718	RB511	9894	RB513	9187	RB515	8575	RB517	8039	RB493	7565	RB495	7106	RB497	6769	RB499	6140	RB501	5569	RB503	5074	RB505	4642	RB507	4264	RB509	3927	
5"								RB535	10325	RB537	9637	RB539	9035	RB541	8435	RB543	7895	RB545	7410	RB547	6980	RB549	6140	RB551	5569	RB553	5074	RB555	4642	RB557	4264	RB559	3927	
5 1/2"										RB557	10382	RB559	9722	RB561	9122	RB563	8583	RB565	8100	RB567	7678	RB569	7297	RB571	6884	RB573	6507	RB575	6150	RB577	5819	RB579	5500	
6"												RB558	10382	RB560	9722	RB562	9122	RB564	8583	RB566	8100	RB568	7678	RB570	7297	RB572	6930	RB574	6584	RB576	6250	RB578	5920	
6 1/2"																					RB563	1612	RB370	1455	RB372	1320	RB374	1206	RB376	1100	RB378	1010	RB380	920

### 1 5/8" RECESSED TYPE STRINGERS CAP. LBS. PER PAIR

LGTH	48"		54"		60"		66"		72"		78"		84"		90"		96"		102"		108"		114"		120"		126"		132"		138"		144"	
Height	Model No.	Cap. lbs.	Model No.	Cap. lbs.	Model No.	Cap. lbs.	Model No.	Cap. lbs.	Model No.	Cap. lbs.	Model No.	Cap. lbs.	Model No.	Cap. lbs.	Model No.	Cap. lbs.	Model No.	Cap. lbs.	Model No.	Cap. lbs.	Model No.	Cap. lbs.	Model No.	Cap. lbs.	Model No.	Cap. lbs.	Model No.	Cap. lbs.	Model No.	Cap. lbs.	Model No.	Cap. lbs.		
2 1/2"	RB380	7143	RB382	6349	RB384	5714	RB386	4800	RB388	4041	RB390	3443	RB392	2970	RB394	2586	RB396	2273	RB364	2014	RB366	1796	RB368	1612	RB370	1455	RB372	1320	RB374	1206	RB376	1100	RB378	1010
3"	RB414	9115	RB416	8102	RB418	7292	RB420	6629	RB422	6077	RB424	5364	RB426	4625	RB428	4030	RB430	3540	RB398	3137	RB399	2798	RB402	2511	RB404	2266	RB406	2055	RB408	1873	RB410	1719	RB412	1574
3 1/2"			RB448	10334	RB450	9310	RB452	8463	RB454	7758	RB456	7161	RB458	6650	RB460	6068	RB462	5333	RB432	4725	RB434	4214	RB436	3782	RB438	3414	RB440	3096	RB442	2821	RB444	2582	RB446	2371
4"				RB480	10886	RB482	9897	RB484	9272	RB486	8374	RB488	7776	RB490	7258	RB492	6804	RB464	6337	RB466	5652	RB468	5072	RB470	4578	RB472	4153	RB474	3783	RB476	3462	RB478	3179	
4 1/2"						RB510	10718	RB512	9894	RB514	9187	RB516	8575	RB518	8039	RB494	7565	RB496	7106	RB498	6769	RB500	6140	RB502	5569	RB504	5074	RB506	4642	RB508	4264	RB510	3927	
5"								RB536	10325	RB538	9637	RB540	9035	RB542	8435	RB544	7895	RB546	7410	RB548	6980	RB550	6140	RB552	5569	RB554	5074	RB556	4642	RB558	4264	RB560	3927	
5 1/2"										RB558	10382	RB560	9722	RB562	9122	RB564	8583	RB566	8100	RB568	7678	RB570	7297	RB572	6930	RB574	6584	RB576	6250	RB578	5920	RB580	5580	
6"												RB559	9722	RB561	9122	RB563	8583	RB565	8100	RB567	7678	RB569	7297	RB571	6930	RB573	6584	RB575	6					



## CENTENNIAL PROFILE ACCESSORIES

### FLUSH SAFETY BAR FOR BOX BEAMS

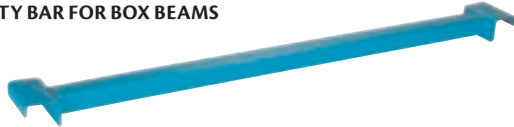

Model No.	Dimensions W" x L"	Wt. Cap. lbs.	Price /Each
RB878	2 x 42	1100	18.10
RB884	6 x 42	1200	25.10
RB872	12 x 42	1200	33.20

### DRUM CRADLE

- For positive positioning of cylindrical containers
- Unit fits onto cross bars and provides wedge type security



Model No.	Description	Price /Each
RB848	Drum cradle (Type II - 42")	55.30

### SKID CHANNELS

- For use with legged skids
- Fits across beams, from front to rear
- Recessed channel provides support for skid legs

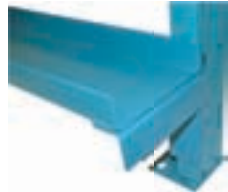

Model No.	Dimensions W" x L"	Price /Each
RB923	6 x 42	31.20

### WALL CONNECTORS

- Wall connectors are used to provide a tie between racking and the wall
- Plate is punched to allow lagging



Model No.	Size"	Price /Each
RB835	6	16.10
RB830	12	16.10

### ROW CONNECTORS

- Row connectors are used on back to back racking layouts to maintain spacing between rows
- May be located at any level other than where a stringer is located



Model No.	Size"	Price /Each
RB327	6	16.10
RB328	8	16.10
RB322	12	16.10

## WIRE DECKING

- Easy to install
- Step/Waterfall style
- Three channels sit on the beam to carry the load
- 2500-lb. capacity
- Colour: Grey

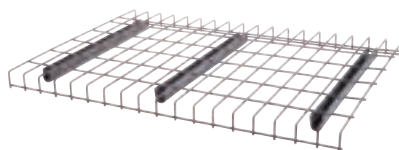

Model No.	Dimensions W" x D"	Price /Each
RL379	46 x 42	43.90
RL380	52 x 42	50.70
RL377	46 x 36	46.90
RL378	52 x 36	51.90

## REDIRACK PROFILE ACCESSORIES

### HOOKOVER SAFETY BAR FOR BOX BEAMS



Model No.	Dimensions W" x L" x H"	Wt. Cap. lbs.	Price /Each
RL034	2 x 42 x 4	1000	19.50

### SAFETY BAR FOR STEP BEAMS

- Sits in pre-slitted Redirack beams
- Prevents pallets from falling between beams
- Galvanized
- Fits 42" frame

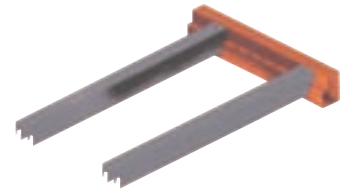

Model No.	Dimensions W" x L"	Wt. Cap. lbs.	Price /Each
RL029	2 x 38	1000	11.10

### WALL TIES

- Designed to protect racking by tying to walls or columns

- Model No. RL843 6"  
Price/Each \$11.60
- Model No. RL844 8"  
Price/Each \$12.60
- Model No. RL845 12"  
Price/Each \$14.20

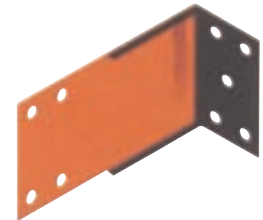

## PALLET RACK BACK GUARDS

Back guards help prevent accidents by keeping pallets and their contents from falling off the back of the rack. These guards increase safety where pedestrian pathways are behind the rack.

- Constructed using a 10-gauge frame, and 2" x 2", 10-gauge wire mesh with stiffeners
- Available in a variety of sizes to fit most pallet rack configurations
- Guard brackets are designed to fit almost any style of rack
- Durable safety yellow finish
- Hardware not included



KH131

ML231

Create a pallet rack back guard designed for your application

1. Choose one or a combination of back guard panels to create the required width and length

Model No.	Dimensions'	Weight lbs.	Price /Each
KH926	1 x 4	10	59.30
KH914	2 x 4	12	70.35
KH930	3 x 4	20	96.60
KD130	4 x 4	23	97.85
KD131	8 x 4	45	130.00

2. Choose a mounting bracket that provides the required depth
  - Minimum of four brackets required

Model No.	Dimensions"	Weight lbs.	Price /Each
ML231	4 x 6	2	11.60
ML232	4 x 9	2	13.85
ML233	4 x 12	3	13.85

3. Hardware required

For each additional panel, add: 2 x MMB721 and 2 x MMH254  
For each mounting bracket, add: 3 x MMP624 and 3 x MMB721

# RACKING/SHELVING

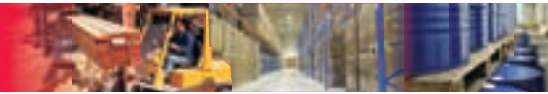

## CANTILEVER BAR-STOCK RACKING

### LIGHT-DUTY

- All-welded components assemble easily
- Seven 12" adjustable arms per column side
- Capacity per level: 1000 lbs.
- Dim.: 36" W x 18 1/4" D x 75" H
- Shipped knocked down
- **FOB Concord, ONT**

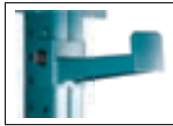

### REGULAR-DUTY

- Ideal for storing of steel, iron, aluminum, wood or plastic pipe
- All-welded components assemble easily
- Seven 14" adjustable arms per column side
- Capacity per level: 2000 lbs.
- Dim.: 36" W or 72" W x 21" D x 84" H
- Shipped knocked down
- **FOB Concord, ONT**



### LIGHT-DUTY

Model No.	Description	Capacity lbs./column	Wt. lbs.	Price /Each
RL730	Single Sided	7000	306	814.00
RL731	Double Sided	14 000	434	1155.00

### REGULAR-DUTY

Model No.	Description	Width"	Capacity lbs./column	Wt. lbs.	Price /Each
<b>STARTER</b>					
RL732	Single-Sided	36	14 000	315	837.00
RL734	Double-Sided	36	28 000	452	1202.00
RL736	Single-Sided	72	14 000	329	875.00
RL738	Double-Sided	72	28 000	466	1239.00

### ADD-ON

RL733	Single-Sided	36	7000	168	445.00
RL735	Double-Sided	36	14 000	236	628.00
RL737	Single-Sided	72	7000	182	482.00
RL739	Double-Sided	72	14 000	250	666.00

## HEAVY-DUTY ADJUSTABLE CANTILEVER RACKING



- Pre-designed and engineered free-standing systems
- Each kit consist of 3 basic components: single or double sided columns, arms and braces
- Column centres are set at 51"
- 3 arms per column for single sided units and 6 arms per column double sided units
- All welded components that are easily assembled
- Tapered columns eliminate deflection of rack into the aisles
- Tapered arms never deflect below horizontal
- Arms easily adjust to any vertical height on 3" centres
- **FOB Concord, Ontario**



Column Height'	Number of Columns	Arm Length"	Length of Material Stored'	Capacity Per /Level	Single Sided Unit Model No.	Price /Each	Double Sided Unit Model No.	Price /Each
8	2	24	5 to 8	4500	RL676	1134.00	RL703	1600.00
8	3	24	9 to 12	5500	RL677	1771.00	RL704	2468.00
8	4	24	13 to 16	8000	RL678	2406.00	RL705	3337.00
8	2	36	5 to 8	4000	RL685	1350.00	RL712	2034.00
8	3	36	9 to 12	4500	RL686	2092.00	RL713	3119.00
8	4	36	13 to 16	6500	RL687	2839.00	RL714	4204.00
8	2	48	5 to 8	3000	RL694	1603.00	RL721	2501.00
8	3	48	9 to 12	3500	RL695	2474.00	RL722	3820.00
8	4	48	13 to 16	5000	RL696	3344.00	RL723	5139.00
10	2	24	5 to 8	4500	RL679	1289.00	RL706	1755.00
10	3	24	9 to 12	5500	RL680	2003.00	RL707	2702.00
10	4	24	13 to 16	8000	RL681	2717.00	RL708	3648.00
10	2	36	5 to 8	4000	RL688	1508.00	RL715	2189.00
10	3	36	9 to 12	4500	RL689	2330.00	RL716	3352.00
10	4	36	13 to 16	6500	RL690	3152.00	RL717	4516.00
10	2	48	5 to 8	3000	RL697	1762.00	RL724	2716.00
10	3	48	9 to 12	3500	RL698	2711.00	RL725	4143.00
10	4	48	13 to 16	5000	RL699	3661.00	RL726	5569.00
12	2	24	5 to 8	4500	RL682	1415.00	RL709	1913.00
12	3	24	9 to 12	5500	RL683	2190.00	RL710	2937.00
12	4	24	13 to 16	8000	RL684	2966.00	RL711	3962.00
12	2	36	5 to 8	4000	RL691	1648.00	RL718	2342.00
12	3	36	9 to 12	4500	RL692	2541.00	RL719	3582.00
12	4	36	13 to 16	6500	RL693	3433.00	RL720	4823.00
12	2	48	5 to 8	3000	RL700	1919.00	RL727	2898.00
12	3	48	9 to 12	3500	RL701	2947.00	RL728	4416.00
12	4	48	13 to 16	5000	RL702	3974.00	RL729	5932.00

Single Side

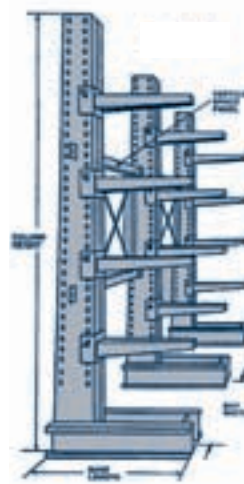

Double Side

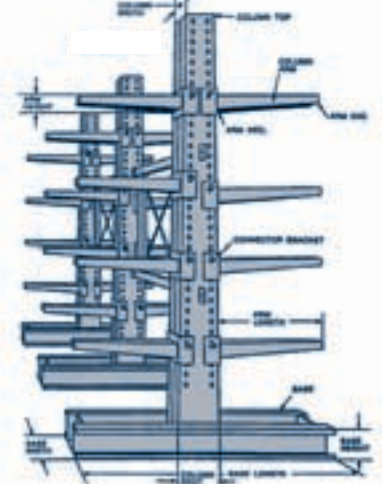

### OTHER OPTIONAL ARMS

#### Lip Stop



Flat plate front end lip stops prevent loose materials from rolling off.

#### Removable Pipes & Sockets



Safely contain broken bundles for elevations that are safely reached from the ground only.

#### Reel Adapters



- Available for reels with diameters of up to 80" and 15 000 lbs.
- Allows easy access to load and unload the coils
- Can be used with automated wire/cable puller equipment

**Custom sizes available. Contact your Material Handling Specialist today for the most efficient and economical rack design and layout with thousands of possible column and arm combinations to suit your specific application.**



## BAR STORAGE RACKS

All-steel vertical and horizontal racks are ideal for storing bars, tube, pipe and angle.

### HORIZONTAL BAR RACKS

- Horizontally stores bars up to 10' long 9" deep arms with 9 storage levels at 6" intervals
- O.A. Dim.: 18" W x 40" D x 84" H
- Capacity: 1800 lbs.
- Weight: 68 lbs.
- Durable Kleton blue enamel finish
- Shipped knocked down

**Model No. RB958**  
**Price/Each \$555.00**



**KLETON**

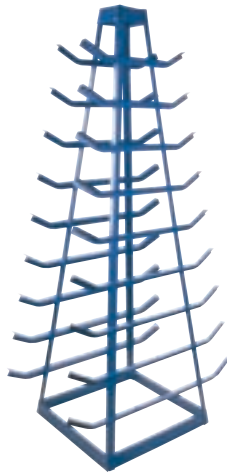

### COMBINATION VERTICAL RACKS

- Vertically stores bars up to 12' long
- 3 shelves for extra storage of small parts
- 8" deep arms divided into 3 sections
- O.A. Dim.: 36" W x 24" D x 84" H
- Capacity: 3000 lbs.
- Weight: 128 lbs.
- Durable Kleton blue enamel finish
- Shipped knocked down

**Model No. RL922**  
**Price/Each \$355.00**



**KLETON**



### VERTICAL BAR RACKS

- All-welded steel construction
- Vertically stores bars up to 10' long
- Four - 24" deep dividers
- O.A. Dim.: 48" W x 24" D x 60" H
- 3000 lbs. capacity
- Weight: 100 lbs.
- Durable Kleton blue enamel finish

**Model No. RL383**  
**Price/Each \$590.00**



**KLETON**



### MOBILE PIPE & BAR RACKS

- Safely stores up to 1000 lbs. of material
- Folds to compact size of 61" x 34" x 15 1/2"
- Features 4 rack levels with curved edges to prevent pipe from rolling off
- Constructed of structural square tubing
- 2 swivel and 2 rigid, 6" hard rubber casters
- O.A. Dim.: 58 1/2" W x 34" D x 58" H
- Weight: 100 lbs.
- Blue enamel finish

**Model No. RB951**  
**Price/Each \$1549.00**

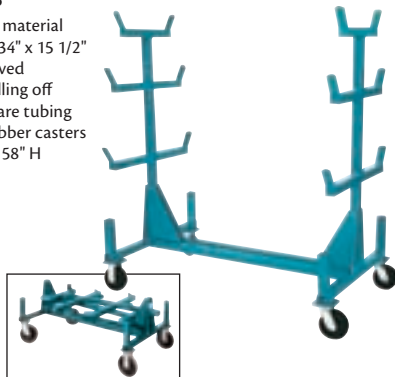

## STANDARD VERTICAL SHEET RACKS

- All-welded steel construction
- Designed for vertically storing sheet goods
- Constructed of heavy gauge steel 1 1/4" tube for bays and a heavy gauge steel 1" x 2" rectangular tube for the frame
- Each bay can hold up to 1000 lbs.
- O.A. Dim.: 84" W x 50" L x 36 3/4" H
- Number of bays: 4
- Distance between bays: 10"
- Weight: 200 lbs.
- Durable Kleton blue enamel finish

**Model No. RL384**  
**Price/Each \$1641.00**

**KLETON**

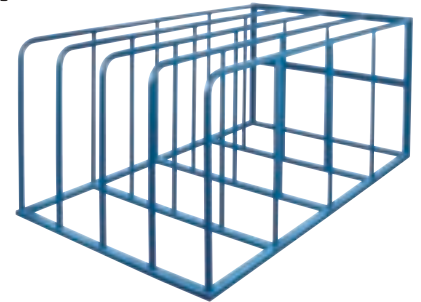

## VERTICAL SHEET STORAGE RACKS

- Accommodates multiple sheet sizes
- All-welded steel construction, 1 1/4" OD round tube dividers
- Two 27" H uprights, two 36" H uprights and one 42" H upright
- Four equal size openings of 7 1/2" clear
- Holes for anchoring to the floor recommended
- Overall dimensions: 36" x 48" x 43 1/2"
- Capacity: 750 lbs. per bay; total of 3000 lbs.
- Shipping weight: 72 lbs.
- Durable Kleton blue enamel finish

**Model No. RN014**  
**Price/Each \$492.00**

**KLETON**



## HORIZONTAL SHEET RACKS

- Designed for storage of sheet materials
- Flat storage fully supports materials and reduces warping
- Sheets are accessible from all four sides
- All-welded construction and the frame is made of 2" square tubing
- Five shelf design creates four storage bays spaced 9 1/2" apart and a open top bay
- Bay Capacity: 2000 lbs. evenly distributed
- Maximum rack capacity: 8000 lbs.

**KLETON**



Model No.	Overall Dim.			Number of Shelves	Net Wt. lbs.	Price /Each		
	L"	W"	H"					
RL923	103	x	55	x	48	5	575	2379.00



## BUILT TO YOUR SPECIFIC DIMENSIONS

**Kleton** specializes in custom requests, be it a small modification to existing designs or a unique requirement. Our team of design specialists can help you get from concept, to drawings, to a finished product. From quantities of one to one thousand, Kleton treats your request with the same attention to detail that has become synonymous with the Kleton name.



# RACKING/SHELVING

## STACKING RACKS

- Rugged all-welded 2" sq. tubing steel construction
- Utilize warehouse airspace and lower the chances of damage that is associated with bulk stacking
- Designed for storage of loose and palletized goods
- Holds 4000 lbs. per rack and can be stacked 4 high
- Durable Kleton blue enamel finish
- Posts and bases are sold separately

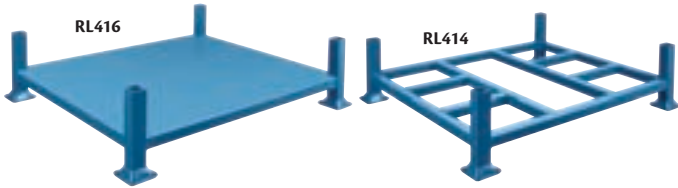

Model RL414  
w/2 Model RL419

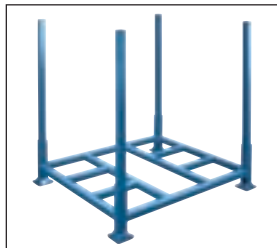

Model RL414  
w/4 Model RL421

Model No.	Inside Dimensions W" x D"	O.A. Dimensions W" x D"	Wt. lbs.	Price /Each
<b>OPEN BASE FRAME</b>				
RL414	44 x 38	48 x 42	85	409.00
RL415	44 x 44	48 x 48	90	454.00
<b>CLOSED BASE FRAME</b>				
RL416	44 x 38	48 x 42	110	486.00
RL417	44 x 44	48 x 48	115	539.00

### ACCESSORIES

Model No.	Description	O.A. Dimensions W" x H"	Wt. lbs.	Price /Each
RL418	42" Side Rail	42 x 48	30	99.50
RL419	48" Side Rail	48 x 48	32	120.00
RL420	42" Upright Post-Pack of 4	2 x 42	35	118.00
RL421	48" Upright Post-Pack of 4	2 x 48	40	141.00
RL422	60" Upright Post-Pack of 4	2 x 60	50	172.00

## RACKING AISLE PROTECTORS

- Prevent collision damage to shelving/racking from fork lifts, pallet trucks or other in-plant vehicle accidents
- Corner wraps are 12" high with an angle of 5" H x 3" W x 1/4" D with holes for anchoring to the floor
- Protectors can be customized to any other lengths and/or depths required
- Floor anchors not included
- Colour: Safety yellow
- Material: Steel



Model No.	Description	O.A. Dimensions L" x W" x H"	Fits Upright	Wt. lbs.	Price /Each
RN059	Single Wrap - Left	46 1/2 x 3 x 12	42 W	38	150.00
RN060	Single Wrap - Right	46 1/2 x 3 x 12	42 W	38	150.00
RN061	Single Wrap - Left	52 1/2 x 3 x 12	48 W	41	159.00
RN062	Single Wrap - Right	52 1/2 x 3 x 12	48 W	41	159.00
RN063	Double Wrap	50 1/4 x 3 x 12	42 W	46	230.00
RN064	Double Wrap	56 1/4 x 3 x 12	48 W	46	258.00

## FLOOR ANGLE GUARD RAILS

- Floor angle guide rail helps keep traffic away from racking and shelving, walls, storage areas, offices, and other work areas
- The sturdy 5" H x 3" W x 1/4" D angle iron comes with holes to anchor to the floor
- Protectors can be customized to any other lengths and/or depths required
- Floor anchors not included
- Colour: Safety yellow
- Material: Steel



Model No.	O.A. Dimensions L" x W" x H"	Wt. lbs.	Price /Each
RN065	48 x 3 x 5	26	70.40
RN066	60 x 3 x 5	33	82.60
RN067	120 x 3 x 5	66	164.00

## SAFETY GUARDS

- Protect your equipment and personnel from accidental damage and injury with these low profile safety guards
- 4" x 4" square tube welded to an 8" x 8" x 1/2" base, complete with four 3/4" diameter holes for anchoring to floor
- Colour: Safety yellow powder coat finish

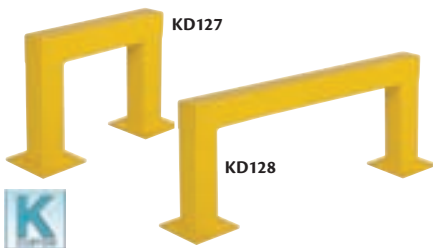

Model No.	Dimensions L" x H"	Wt. lbs.	Price /Each
KD127	24 x 18	65	272.00
KH855	36 x 18	75	325.00
KD128	48 x 18	85	329.00
KD136	24 x 42	95	362.00
KD139	48 x 42	115	408.00

## UPRIGHT PROTECTORS

- Protects industrial racking from damaging impacts that cause unsafe conditions
- Made from 1/4" thick steel
- 4 pre-drilled holes made for 1/2" anchors (not included)
- Safety yellow powder coated finish



Model No.	O.A. Dimensions W" x D" x H"	Wt. lbs.	Price /Each
KH858	7 x 7 x 12	12	37.45
RB925	7 x 7 x 18 1/4	15	49.90

## HEAVY-DUTY STEEL BOLLARDS

- Protect your warehouse equipment, as well as high traffic areas with these heavy-duty steel bollards
- 4" x 4" square tube welded to an 8" x 8" x 1/2" steel base complete with four 3/4" diameter holes for anchoring to floor
- Safety yellow powder coated finish

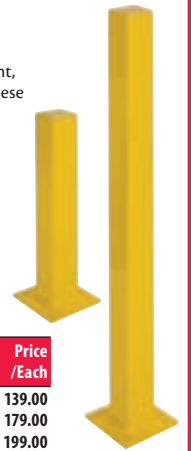

Model No.	Height"	Wt. lbs.	Price /Each
KD125	24	30	139.00
KH857	36	40	179.00
KD126	48	50	199.00



## EXTRA HEAVY-DUTY SHELVING

### DESIGNED TO HOLD THE HEAVIEST LOADS

- Clear access on all four sides
- Excellent for storage of dies, fixtures, jigs or any heavy material
- Formed angle 2" x 2" uprights are constructed of 13 gauge steel, punched on 1" centres for quick and easy shelf adjustment
- Grey powder coat finish
- Shelf capacities are based on loads that are evenly distributed
- Extra shelves and 96" high units are available
- Each unit includes 5 shelves

Model No.	Dimensions W" x D" x H"	Cap /Shelf lbs.	Wt. lbs.	Price /Each
RC524	36 x 18 x 72	3000	167	616.00
RC525	48 x 18 x 72	3000	212	828.00
RC526	60 x 18 x 72	3000	252	932.00
RC527	36 x 24 x 72	3000	197	763.00
RC528	48 x 24 x 72	3000	242	858.00
RC529	60 x 24 x 72	3000	292	1142.00

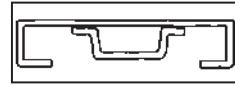

#### Shelves:

14-gauge, 2" deep channels on all four sides  
An extra channel welded to the bottom of shelf to prevent flexing under heavy loads.



## HEAVY-DUTY BULK STORAGE RACKS

- These racks bridge the gap between pallet racking and conventional industrial racking
- Engineered for hand loading of intermediate weight bulky items
- Constructed of all welded 14-gauge steel upright frames punched on 2" centres
- 14-gauge "Z" step beam design provides maximum weight capacity
- Comes with 5/8" thick particle board decking (steel decking also available)
- Additional shelves include 2 beams and a deck
- Other dimensions also available



Innovative "Z" Beam Design

Rack Height'	Rack Width"	Cap. lbs. per shelf	Starter Model No.	Wt. lbs.	Price /Each	Add-on Model No.	Wt. lbs.	Price /Each
<b>STANDARD 3 SHELF UNITS - 24" DEEP UNIT</b>								
6	60	4000	RK028	181	606.00	RK046	158	525.00
	72	3500	RK029	205	683.00	RK047	182	603.00
	96	2800	RK030	253	798.00	RK048	230	720.00
8	60	4000	RK031	199	645.00	RK049	167	546.00
	72	3500	RK032	223	723.00	RK050	191	609.00
	96	2800	RK033	271	837.00	RK051	239	724.00
<b>STANDARD 3 SHELF UNITS - 36" DEEP UNIT</b>								
6	60	4000	RK040	221	679.00	RK052	196	594.00
	72	3500	RK041	254	796.00	RK053	229	694.00
	96	2800	RK042	317	945.00	RK054	292	843.00
8	60	4000	RK043	243	735.00	RK055	207	612.00
	72	3500	RK044	276	834.00	RK056	240	715.00
	96	2800	RK045	339	983.00	RK057	303	864.00

#### ADDITIONAL SHELVES

Rack Width"	24" Deep unit	Wt. lbs.	Price /Each	36" Deep unit	Wt. lbs.	Price /Each
60	RK058	45	144.00	RK061	57	165.00
72	RK059	53	169.00	RK062	68	199.00
96	RK060	69	208.00	RK063	89	249.00

## ULTRARACK HEAVY-DUTY BOLTLESS SHELVING

- Modular Design; use as storage shelving, a work centre or assemble as a workbench
- Heavy-duty 16-gauge steel construction provides maximum weight carrying capacity
- Each shelf supports 600 - 1800 lbs. based on evenly distributed loads
- Double riveted beams lock into heavy-duty corner post to form a structurally secure unit
- Includes five particleboard shelves that adjust easily on 1 1/2" centres
- Convenient access from all four sides
- Tough baked enamel finish



Model No.	Mfg. No.	Dimensions W" x D" x H"	Cap/Shelf lbs.	Price /Each
RL894	UR1836	36 x 18 x 72	1200	215.00
RL895	UR2436	36 x 24 x 72	1800	239.00
RL896	UR1848	48 x 18 x 72	1000	245.00
RL897	UR2448	48 x 24 x 72	1400	275.00

## ECONOMICAL COMMERCIAL SHELVING

- For light duty applications, this is the perfect shelving for your office, storeroom, garage or shop
- Capacity: 300 lbs. per shelf evenly distributed
- Shelves can be adjusted on 1" centres without disturbing shelves in each adjoining unit
- The use of a Kwik Klip system will allow for a quick and easy shelf installation
- All steel construction with a baked enamel tan finish
- Available in an open or closed style
- Each unit includes 5 shelves
- Also available with 6 or 8 shelves



Model No.	Size W" x D" x H"	Wt. lbs.	Price /Each
<b>OPEN STYLE</b>			
RB971	36 x 12 x 75	47	169.00
RB973	36 x 15 x 75	54	189.00
RB975	36 x 18 x 75	60	215.00
RB977	36 x 24 x 75	66	269.00
<b>CLOSED STYLE</b>			
RB972	36 x 12 x 75	84	299.00
RB974	36 x 15 x 75	95	329.00
RB976	36 x 18 x 75	105	389.00
RB978	36 x 24 x 75	120	455.00

# RACKING/SHELVING

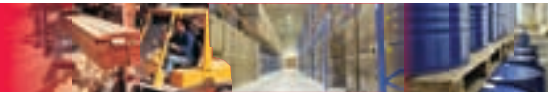

## PRONTO BULK STORAGE RACKS

- Shelving units are ideal for storage of heavy/bulk merchandise
- Feature a maximum capacity of 8000 lbs./section and 2000 lbs./shelf
- Easy and quick installation, only 4 components involved: beams, frames, shelving and safety bars
- Vertical adjustability of beams in 4" increments provides the flexibility to suit your changing warehousing needs
- Frames and beams lock easily and securely
- Each Pronto bulk storage rack starter unit is comprised of two all-welded end frames, and three 5/8" presswood shelves flush-fitted into positive locking steel shelf beams (2 per shelf)
- Add-on units include only one end frame
- Additional shelves may be added into any unit at 4" vertical centres
- Order one starter unit, and multiple add-ons for a continuous racking set-up
- For extra stability and rigidity all units feature 3 safety bars per shelf
- Various other dimensions are available in Pronto racking
- Rack only units (no wood shelves) are available upon inquiry
- Centennial blue enamel finish

**Note:** Not recommended for powered lift truck applications.

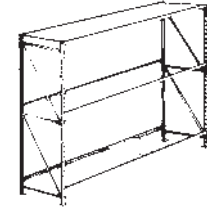
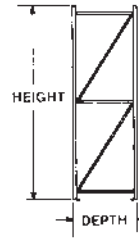
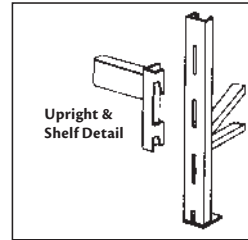
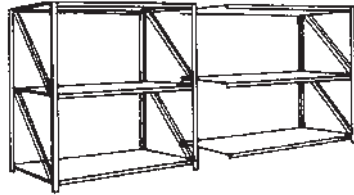

24" SHELF DEPTH

36" SHELF DEPTH

48" SHELF DEPTH

Size W' x H'	Description	Cap. per level lbs.	Model No.	Wt. lbs.	Price /Each	Model No.	Wt. lbs.	Price /Each	Model No.	Wt. lbs.	Price /Each
7 x 8	Starter	1400	RA443	245	652.00	RA475	288	758.00	RA507	331	830.00
7 x 8	Add-on	1400	RA441	217	564.00	RA473	258	663.00	RA505	299	732.00
7	Add'l shelf	1400	RA470	63	158.00	RA502	76	190.00	RA534	89	211.00
8 x 10	Starter	2000	RA453	302	790.00	RA485	351	904.00	RA517	400	961.00
8 x 10	Add-on	2000	RA451	268	677.00	RA483	315	786.00	RA515	362	840.00
8	Add'l shelf	2000	RA471	78	188.00	RA503	93	223.00	RA535	108	240.00
8 x 12	Starter	2000	RA463	316	810.00	RA495	365	924.00	RA527	414	983.00
8 x 12	Add-on	2000	RA461	275	687.00	RA493	322	796.00	RA525	369	851.00
8	Add'l shelf	2000	RA471	78	188.00	RA503	93	223.00	RA535	108	240.00

22-GA. GALVANIZED SHELF PANELS

7/8" Model No.	1 3/8" Model No.	Size"	Cap. lbs.	Price /Each
RB889	RB020	6 x 24	258	6.12
RB890	RB021	6 x 30	200	9.18
RB891	RB022	6 x 36	165	10.20
RB892	RB023	6 x 42	139	10.20
RB893	RB024	6 x 48	120	15.30

## BULK STORAGE RACKS

- Ideal solution for storage of large and bulky items
- Designed to work without nuts and bolts allows for assembly in minutes
- Shelves are adjustable in 1 1/2" increments
- Optional particle board deck panels combine economy and strength and are easy to install
- Units come standard with sturdy 84" high, 14-gauge posts and left to right beams as well as 16-gauge front to back beams
- Double riveted beams lock into corner posts to eliminate back and side sway
- Durable baked gray enamel finish to resist rust and corrosion
- Shipped knocked down

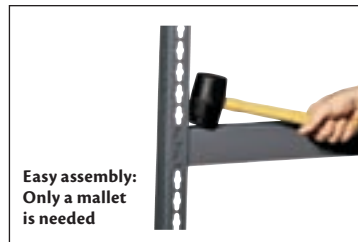

Easy assembly:  
Only a mallet  
is needed



3 LEVELS

4 LEVELS

PARTICLE BOARD DECK

Dimensions W" x D" x H"	Shelf cap lbs.	Model No.	Wt. lbs.	Price /Each	Model No.	Wt. lbs.	Price /Each	Model No.	Wt. lbs.	Price /Each
48 x 24 x 84	1200	RL124	62	250.00	RL139	74	302.00	RL154	20	29.90
48 x 36 x 84	1200	RL125	68	279.00	RL140	82	343.00	RL155	29	44.50
48 x 48 x 84	1200	RL126	74	306.00	RL141	90	379.00	RL156	39	59.10
60 x 24 x 84	1000	RL127	72	265.00	RL142	88	324.00	RK016	25	36.90
60 x 36 x 84	1000	RL128	78	295.00	RL143	96	365.00	RK019	37	55.50
60 x 48 x 84	1000	RL129	84	323.00	RL144	104	401.00	RL157	49	73.90
72 x 24 x 84	750	RL130	74	286.00	RL145	90	351.00	RK017	29	46.50
72 x 36 x 84	750	RL131	80	316.00	RL146	98	391.00	RK020	44	69.90
72 x 48 x 84	750	RL132	86	344.00	RL147	106	427.00	RL158	59	88.90
96 x 24 x 84	600	RL133	86	381.00	RL148	106	478.00	RK018	39	61.50
96 x 36 x 84	600	RL134	92	434.00	RL149	114	549.00	RK021	59	92.90
96 x 48 x 84	600	RL135	98	483.00	RL150	122	613.00	RL159	78	119.00
96 x 24 x 84	800	RL136	98	422.00	RL151	122	532.00	RK018	3	61.50
96 x 36 x 84	800	RL137	104	475.00	RL152	130	603.00	RK021	59	92.90
96 x 48 x 84	800	RL138	110	569.00	RL153	138	667.00	RL159	78	119.00



## WIDE SPAN RECORD STORAGE SHELVING

- Efficiently organize and store all records in a single information retrieval center
- Record management is facilitated with easy to identify printed storage boxes
- 12-gauge steel posts and beams and warp free particle board decks provides maximum strength
- Easy to install with snap together shelf beams, no nuts and bolts
- Storage boxes constructed of white corrugated fibreboard, with handles, making it a durable and easily maneuverable box, a perfect choice for economical storage
- Order complete units, including shelving, deck and boxes, or shelving with deck only
- Colour: Grey



Model No.	No. of Shelves	Size			No. of Boxes	Capacity lbs.	Price /Each
		L" x D" x H"					
<b>SHELVING &amp; DECK ONLY (WITHOUT BOXES)</b>							
RL997	3	72 x 18 x 60			-	800	246.00
RL998	3	72 x 32 x 60			-	800	348.00
RL999	4	72 x 18 x 84			-	800	325.00
RN001	4	72 x 32 x 84			-	800	451.00
RN002	3	42 x 18 x 60			-	1340	179.00
RN003	3	42 x 32 x 60			-	1340	263.00
RN004	4	42 x 18 x 84			-	1340	235.00
RN005	4	42 x 32 x 84			-	1340	338.00

Model No.	No. of Shelves	Size			No. of Boxes	Capacity lbs.	Price /Each
		L" x D" x H"					
<b>COMPLETE UNITS (INCLUDES SHELVING, DECK &amp; BOXES)</b>							
RN006	3	72 x 18 x 60			30	800	474.00
RN007	3	72 x 32 x 60			60	800	804.00
RN008	4	72 x 18 x 84			40	800	629.00
RN009	4	72 x 32 x 84			80	800	1059.00
RN010	3	42 x 18 x 60			18	1340	315.00
RN011	3	42 x 32 x 60			36	1340	537.00
RN012	4	42 x 18 x 84			24	1340	417.00
RN013	4	42 x 32 x 84			48	1340	703.00

## EASY-UP 5000 SHELVING

- Offers the look of office shelving, the strength of industrial shelving and the economy of commercial shelving
- All shelving features 14 gauge beams front and back that adjust on 1" centres
- No cross braces required
- Loads can be accessed from all sides
- Designed for easy, trouble-free installation
- Beam and side braces hook into post slots to form a rigid frame
- No nuts, bolts nor clips required, thereby saving installation time and cost
- Shelves can easily be adjusted or added to your system at any time

### COMPONENTS:

- End frames have slots on 1" centres, covering 3 sides with a clean front view
- Marked on 6" centres for quick beam installation. Half slots on top for flush mounted top shelf
- Frame connectors designed with a patented locking tab to be turned into the upright for safety and rigidity
- Beams have a double locking clip V-type design to support the particle board shelf
- Finished with a baked-on alkyd enamel over corrosion resistant phosphate undercoat
- Colour: Almond beige

Model No. RH907 Foot plate  
Price/Each \$2.84



### 5-SHELF UNITS

Shelf Size D" x W"	Cap. per shelf lbs.	74" H		86" H		98" H	
		Model No.	Price /Each	Model No.	Price /Each	Model No.	Price /Each
<b>STARTER UNITS</b>							
12 x 36	400	RH798	247.00	RH807	267.00	RH816	279.00
12 x 48	300	RH799	272.00	RH808	293.00	RH817	305.00
18 x 36	400	RH801	269.00	RH810	290.00	RH819	303.00
18 x 48	300	RH802	300.00	RH811	319.00	RH820	333.00
24 x 36	400	RH804	292.00	RH813	312.00	RH822	325.00
24 x 48	300	RH805	325.00	RH814	349.00	RH823	362.00
<b>ADD-ON UNITS</b>							
12 x 36	400	RH825	175.00	RH834	186.00	RH843	192.00
12 x 48	300	RH826	201.00	RH835	211.00	RH844	217.00
18 x 36	400	RH828	196.00	RH837	206.00	RH846	212.00
18 x 48	300	RH829	225.00	RH838	236.00	RH847	242.00
24 x 36	400	RH831	214.00	RH840	224.00	RH849	232.00
24 x 48	300	RH832	251.00	RH841	261.00	RH850	268.00

### 6-SHELF UNITS

Shelf Size D" x W"	Cap. per shelf lbs.	74" H		86" H		98" H	
		Model No.	Price /Each	Model No.	Price /Each	Model No.	Price /Each
<b>STARTER UNITS</b>							
12 x 36	400	RH852	267.00	RH861	288.00	RH870	301.00
12 x 48	300	RH853	298.00	RH862	318.00	RH871	332.00
18 x 36	400	RH855	294.00	RH864	314.00	RH873	327.00
18 x 48	300	RH856	329.00	RH865	350.00	RH874	363.00
24 x 36	400	RH858	319.00	RH867	340.00	RH876	353.00
24 x 48	300	RH859	363.00	RH868	384.00	RH877	397.00
<b>ADD-ON UNITS</b>							
12 x 36	400	RH879	197.00	RH888	207.00	RH897	213.00
12 x 48	300	RH880	227.00	RH889	238.00	RH898	244.00
18 x 36	400	RH882	220.00	RH891	231.00	RH900	237.00
18 x 48	300	RH883	256.00	RH892	266.00	RH901	272.00
24 x 36	400	RH885	242.00	RH894	252.00	RH903	259.00
24 x 48	300	RH886	287.00	RH895	297.00	RH904	303.00

# RACKING/SHELVING

## HEAVY-DUTY ULTRACAP™ STEEL SHELVING

- Industrial-grade shelving made from 20-gauge steel is available in starter and add-on units for a wide variety of storage solutions
- Six 20-gauge welded tubular box shelves with lapped and welded corners provide for total capacity from 650 to 1100 lbs. per shelf based on evenly distributed loads
- 14-gauge box formed front posts provide full shelf access and assembly time when joining multiple units
- Posts are punched on 1" centres for easy shelf adjustment and a variety of configurations
- Powder coat grey finish provides added protection from chipping and rust
- Shipped knocked down



### EXTRA SHELVES

Model No	Dimensions Width" Depth"	Wt. lbs.	Price /Each
RL244	36 12	8	26.50
RL245	36 18	10	27.90
RL246	36 24	13	34.50
RL247	48 12	10	34.90
RL248	48 18	13	43.90
RL308	48 24	15	135.00

### SHELVING UNITS

Model No	Unit Type	Dimensions Width" Depth" Height"	Shelf Capacity lbs.	Wt. lbs.	Price /Each
RL220	Starter Open	36 12 85	1000	89	235.00
RL221	Starter Open	36 18 85	1050	102	242.00
RL222	Starter Open	36 24 85	1100	124	279.00
RL223	Starter Open	48 12 85	650	102	283.00
RL224	Starter Open	48 18 85	675	124	329.00
RL225	Starter Open	48 24 85	750	149	337.00
RL226	Add-on Open	36 12 85	1000	76	211.00
RL227	Add-on Open	36 18 85	1050	89	216.00
RL228	Add-on Open	36 24 85	1100	110	253.00
RL229	Add-on Open	48 12 85	650	89	257.00
RL230	Add-on Open	48 18 85	675	110	304.00
RL231	Add-on Open	48 24 85	750	135	310.00

Model No	Unit Type	Dimensions Width" Depth" Height"	Shelf Capacity lbs.	Wt. lbs.	Price /Each
RL232	Starter Closed	36 12 85	1000	126	330.00
RL233	Starter Closed	36 18 85	1050	147	351.00
RL234	Starter Closed	36 24 85	1100	178	402.00
RL235	Starter Closed	48 12 85	650	147	404.00
RL236	Starter Closed	48 18 85	675	177	471.00
RL237	Starter Closed	48 24 85	750	211	743.00
RL238	Add-on Closed	36 12 85	1000	107	294.00
RL239	Add-on Closed	36 18 85	1050	124	315.00
RL240	Add-on Closed	36 24 85	1100	150	360.00
RL241	Add-on Closed	48 12 85	650	128	370.00
RL242	Add-on Closed	48 18 85	675	153	429.00
RL243	Add-on Closed	48 24 85	750	182	448.00

## COUNTER SHELVING

- Features a rugged 14-gauge steel countertop to provide a practical, useful work surface
- Each section is 36" wide, 18" or 24" deep and 39" high
- Available in 3 shelf open or closed and 4 shelf closed
- All shelves are adjustable up or down on 1 1/2" centres
- Shelf capacity, 900 lbs evenly distributed
- Tops are 21 7/16" deep for 18" counters, and 27 7/16" deep for 24" counters
- Open counter shelving is ideal for packing, assembly and inspection work, where bin openings are not required
- Closed-counter design offers barrier-separations for partitioning off areas, plus concealed storage under top
- Ideal for toolrooms, repair shops, auto parts stores, warehouses etc.
- Colour: Dove grey, other colours available
- Shipped knocked down



Open Shelf Unit



Closed Shelf Unit



### 18" DEEP

### 24" DEEP

SHELF TYPE	Steel Gauge	Starter Model No.	Price /Each	Add-on Model No.	Price /Each	Starter Model No.	Price /Each	Add-on Model No.	Price /Each
<b>3 SHELF OPEN</b>									
Heavy Duty	20	RG597	589.00	RG598	498.00	RG601	640.00	RG602	518.00
Standard	18	RG599	601.00	RG600	508.00	RG603	645.00	RG604	550.00
<b>3 SHELF CLOSED</b>									
Heavy Duty	20	RG605	692.00	RG606	581.00	RG609	748.00	RG610	633.00
Standard	18	RG607	701.00	RG608	592.00	RG611	757.00	RG612	640.00
<b>4 SHELF CLOSED</b>									
Heavy Duty	20	RG613	745.00	RG614	637.00	RG617	820.00	RG618	704.00
Standard	18	RG615	764.00	RG616	652.00	RG619	830.00	RG620	713.00

## MAGNUM BIN SHELVING UNITS

- Dimensions: 42" W x 18" D x 76" H
- Capacity: 480 lbs. per shelf
- Shipped knocked down

### SERIES QMS531

- 27 QMS531 open hopper bins  
19 3/4" L x 12 3/8" W x 5 7/8" H
- 10 heavy-duty grey enamel shelves

### SERIES QMS532

- 21 QMS532 open hopper bins,  
19 3/4" L x 12 3/8" W x 7 7/8" H
- 8 heavy-duty grey enamel shelves

Model No.				Description	Price /Each
Red	Blue	Yellow	Green		
<b>QMS532 SERIES BIN SHELF UNIT</b>					
CF072	CF073	CF074	CF075	Starter	876.00
CF089	CF090	CF091	CF092	Add-on	836.00
<b>QMS531 SERIES BIN SHELF UNIT</b>					
CF188	CF185	CF186	CF187	Starter	1001.00
CF784	CF785	CF786	CF787	Add-on	941.00



CF187



CF074

## MAGNUM BIN SHELVING UNITS

- Dimensions: 42" W x 18" D x 76" H
- Capacity: 480 lbs. per shelf
- Shipped knocked down

### SERIES QMS516

- 4 QMS543 red, 3 QMS533 blue,  
6 QMS532 yellow and  
3 QMS531 blue open hopper bins
- 7 heavy-duty grey enamel shelves

### SERIES QMS533

- 15 QMS533 open hopper bins  
19 3/4" W x 12 3/8" D x 11 7/8" H
- 6 heavy-duty grey enamel shelves

Model No.				Description	Price /Each
Red	Blue	Yellow	Green		
<b>QMS533 SERIES BIN SHELF UNIT</b>					
CF080	CF081	CF082	CF083	Starter	745.00
CF097	CF098	CF099	CF100	Add-on	705.00
<b>QMS516 SERIES BIN SHELF UNIT</b>					
CF189*	-	-	-	Starter	758.00
CF788*	-	-	-	Add-on	734.00

\* Mixed colours



CF189



CF081

## OPEN HOPPER STORAGE SHELF UNITS

### QUS239 SERIES

- 28 QUS239 Series bins  
11" L x 8 1/4" W x 7" H
- 8 heavy-duty grey enamel shelves
- 36" W x 12" D x 76" H
- Cap.: 630 lbs. per shelf
- Shipped knocked down

### QUS240 SERIES

- 28 QUS240 Series bins  
14 3/4" L x 8 1/4" W x 7" H
- 8 heavy-duty grey enamel shelves
- 36" W x 12" D x 76" H
- Cap.: 630 lbs. per shelf
- Shipped knocked down

Model No.						Description	No. of Shelves	Price /Each
Black	Blue	Yellow	Red	Ivory	Green			
<b>QUS239 SERIES BINS SHELF UNIT</b>								
CF176	CF118	CF119	CF120	CF121	CF122	Starter	8	589.00
CF180	CF140	CF141	CF142	CF143	CF144	Add-On	8	549.00
<b>QUS240 SERIES BINS SHELF UNIT</b>								
CF178	CF123	CF124	CF125	CF126	CF127	Starter	8	658.00
CF182	CF150	CF151	CF152	CF153	CF154	Add-On	8	618.00



CF118



CF126



# RACKING/SHELVING

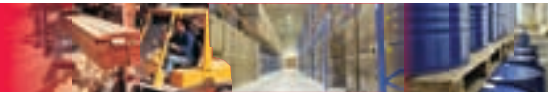

## WIDE SPAN SHELVING WITH JUMBO PLASTIC BINS

- Ideal for storing supplies in warehouses or shops
- No bolt shelving system can be built quickly and easily
- 12-gauge steel posts and 13-gauge beams
- Shelf levels include 5/8" particleboard decking and required tie bars
- Capacity is 800 lbs. per shelf evenly distributed
- Offered configurations include three levels with 12 bins and four levels with 16 bins
- Plastic bin dimensions: 15 1/2" W x 25" D x 13" H
- Assembly required



RL984

KLETON



RL989



Model No.	Shelving Size			No. of Shelves	No. of Bins	Colour	Price /Each
	W" x D" x H"	x	x				
RL984	66 x 18 x 60	x	60	3	12	Red	633.00
RL985	66 x 18 x 60	x	60	3	12	Blue	633.00
RL986	66 x 18 x 60	x	60	3	12	Green	633.00
RL987	66 x 18 x 60	x	60	3	12	Yellow	633.00
RL988	66 x 18 x 60	x	60	3	12	Red, Blue, Yellow	633.00
RL980	66 x 18 x 72	x	72	4	16	Red	835.00
RL981	66 x 18 x 72	x	72	4	16	Blue	835.00
RL982	66 x 18 x 72	x	72	4	16	Green	835.00
RL983	66 x 18 x 72	x	72	4	16	Yellow	835.00
RL989	66 x 18 x 72	x	72	4	16	Red, Blue, Yellow, Green	835.00

## GIANT STACK CONTAINER SHELF UNITS

- Includes 10 QGH700 storage bins and heavy-duty grey enamel shelves
- 42" W x 18" D x 76" H
- Capacity: 500 lbs. per shelf
- Shipped knocked down



Grey	Model No.				Description	No. of Shelves	Price /Each
	Blue	Ivory	Black	Red			
CF056	CF057	CF059	CF060	CF066	Starter	6	519.00
CF061	CF062	CF064	CF065	CF067	Add-On	6	479.00

## OPEN HOPPER STORAGE SHELF UNITS

### QUS 250 SERIES

- 14 QUS 250 Series bins 14 3/4" L x 16 1/2" W x 7" H
- 8 heavy-duty grey enamel shelves
- 36" W x 12" D x 76" H
- Cap.: 630 lbs. per shelf
- Shipped knocked down

### QUS 240 & 230 SERIES

- 8 QUS 240 Series bins 14 3/4" L x 8 1/4" W x 7" H
- 36 QUS 230 Series bins 11" L x 5 1/2" W x 5" H
- 9 heavy-duty grey enamel shelves
- 36" L x 12" D x 76" H
- Cap.: 630 lbs. per shelf
- Shipped knocked down

Model No.						Description	No. of Shelves	Price /Each
Black	Blue	Yellow	Red	Ivory	Green			
QUS 250 SERIES BINS SHELF UNIT								
CF177	CF128	CF129	CF130	CF131	CF132	Starter	8	559.00
CF181	CF145	CF146	CF147	CF148	CF149	Add-On	8	519.00
QUS 240 & 230 SERIES BINS SHELF UNIT								
CF179	CF133	CF134	CF135	CF136	CF137	Starter	9	677.00
CF183	CF175	CF155	CF156	CF157	CF158	Add-On	9	637.00



CF132



CF135

## SLOTTED ANGLE SHELVING

- Ideal for shelving and storage systems, workbenches, tubing storage, protective framing around machinery, platforms around assembly projects, etc.
- Choose from the various components available, or pre-configured shelf units
- Unique boltless clip design allows for adjustability of shelves easily and effortlessly
- To ensure stability, it is recommended that three shelf levels are bolted when using boltless clips
- All shelving units include four steel posts (1 3/8" x 1 3/8" slotted angle), galvanised shelves, galvanised panels (for closed units), plastic feet and all necessary hardware
- Assembly required



RH701



RH774

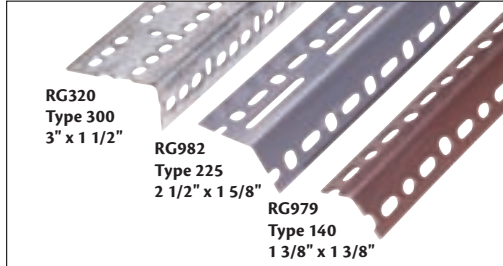

Steel slotted angle allows you to design and build anything to your own specifications:

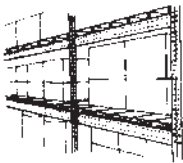

Metal Decking

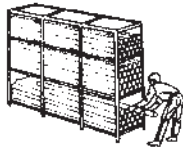

Tubing Storage

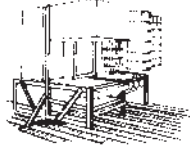

Overhead Storage

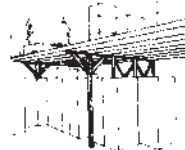

Overhead Storage

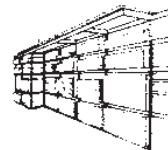

Wide Storage

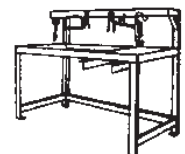

Special Work Benches

6 SHELVES/72" POST      7 SHELVES/84" POST      8 SHELVES/96" POST

Size W" x L"	OPEN		CLOSED		OPEN		CLOSED		OPEN		CLOSED	
	Model No.	Price /Each	Model No.	Price /Each	Model No.	Price /Each	Model No.	Price /Each	Model No.	Price /Each	Model No.	Price /Each
12 x 36	RH701	225.00	RH774	543.00	RH707	260.00	RH780	567.00	RH713	294.00	RH786	672.00
18 x 36	RH702	264.00	RH775	599.00	RH708	306.00	RH781	723.00	RH714	347.00	RH787	727.00
24 x 36	RH703	304.00	RH776	638.00	RH709	352.00	RH782	791.00	RH715	399.00	RH788	856.00
12 x 48	RH704	258.00	RH777	594.00	RH710	298.00	RH783	662.00	RH716	339.00	RH789	763.00
18 x 48	RH705	310.00	RH778	663.00	RH711	359.00	RH784	833.00	RH717	408.00	RH790	835.00
24 x 48	RH706	361.00	RH779	715.00	RH712	419.00	RH785	915.00	RH718	476.00	RH791	980.00

Model No.	Dimensions W" x D"	Angle Length'	Steel Gauge	Type	UDL*	Wt. lbs.	Price /Each
-----------	-----------------------	------------------	----------------	------	------	-------------	----------------

### SLOTTED ANGLE POSTS

RG979	1 3/8" x 1 3/8"	8	14	140	-	6	21.20
RG980	1 3/8" x 1 3/8"	10	14	140	-	7	26.50
RG981	1 3/8" x 1 3/8"	12	14	140	-	8.5	31.80
RG982	2 1/2" x 1 5/8"	8	14	225	-	9	27.30
RG983	2 1/2" x 1 5/8"	10	14	225	-	11	37.70
RG984	2 1/2" x 1 5/8"	12	14	225	-	13	45.00
RG320**	3" x 1 1/2"	10	12	300	-	14	68.40
RG321**	3" x 1 1/2"	12	12	300	-	17	81.00

### GALVANISED SHELVES

RG985	12" x 36"	-	20	-	450	7	25.20
RG986	15" x 36"	-	20	-	450	8.3	38.80
RG987	18" x 36"	-	20	-	450	9.6	32.60
RG988	24" x 36"	-	20	-	450	12.2	39.90
RG989	32" x 42"	-	18	-	300	23.7	76.80
RG990	12" x 48"	-	20	-	350	9.2	31.40
RG991	15" x 48"	-	20	-	350	10.9	42.00
RG992	18" x 48"	-	20	-	350	12.6	41.10
RG993	24" x 48"	-	19	-	400	18.5	47.60

\*UDL: Maximum uniformly distributed load allowance where maximum shelf deflection is fully recovered when load is removed.

\*\*Galvanised steel

Model No.	Dim. W" x H"	Steel Gauge	Wt. lbs.	Price /Each
-----------	-----------------	----------------	-------------	----------------

### GALVANISED SIDE PANELS

RH759	12" x 72"	24	7	83.20
RH760	18" x 72"	24	11	77.90
RH761	24" x 72"	24	15	92.80
RH762	12" x 84"	24	8	74.60
RH763	18" x 84"	24	13	134.00
RH764	24" x 84"	24	17	150.00
RH765	12" x 96"	24	10	110.00
RH766	18" x 96"	24	14	111.00
RH767	24" x 96"	24	19	149.00

Model No.	Dim. W" x H"	Steel Gauge	Wt. lbs.	Price /Each
-----------	-----------------	----------------	-------------	----------------

### GALVANISED BACK PANELS

RH768	36" x 72"	24	22	151.00
RH769	48" x 72"	24	29	159.00
RH770	36" x 84"	24	25	161.00
RH771	48" x 84"	24	34	227.00
RH772	36" x 96"	24	29	176.00
RH773	48" x 96"	24	38	227.00

### GALVANISED KICK PANELS

RH792	36" x 3"	20	1.3	32.50
RH793	48" x 3"	20	1.7	35.00

## SLOTTED ANGLE ACCESSORIES

### CORNER GUSSET PLATES

- Add strength and rigidity to your slotted angle assembly
- 3" W x 3" L

### PLASTIC FEET

- 1 3/8" x 1 3/8" angle posts



### ACCESSORIES

Model No.	Description	Wt. lbs.	Price /Each
RG994	Corner Gusset Plate 3"	0.70	0.93
RG995	Nut and Bolt	0.05	0.30
RG996	Boltless Shelf Clip	0.60	0.70
RL344*	Plastic Foot for Single Post	0.02	2.85
RG238*	Plastic Foot for Double T-Post	0.03	5.65

\*For 1 3/8" X 1 3/8" posts

# RACKING/SHELVING

**METALWARE**  
STEEL SHELVING  
corporation

## BOLTLESS SHELVING UNITS

- Adjustable shelving system that provides high strength, yet economical storage capacity for your needs
- This system uses an innovative shelf clip, which slips into a slotted "T" post and is immediate ready to receive a shelf
- No-Bolt design reduces up to 80% of installation time
- Colour: Grey
- Ships knocked down



**RK550**  
"T" Post

**RK565**  
**RK474**  
Side and back braces



**RK521**  
End Panels

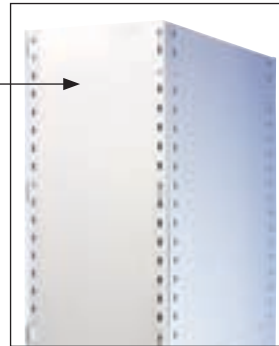

**RK483**  
Base Plate

## "T" POSTS

- For open style shelving includes slots every 1" for shelf or brace installation
- 1 1/2" x 2" x 1/8" double-formed steel in a "T" style with a smooth unperforated face
- Capacity 11000 lbs.

Model No.	Height	Wt. lbs.	Price /Each
RK549	3'4"	4	12.50
RK550	6'4"	8	20.60
RK551	7'4"	9	22.60
RK548	8'4"	10	26.70
RK544	9'4"	11	34.10

## SHELVES

- Shelves are easily installed using four clips
- Constructed from 18-gauge steel
- 4 clips included with each shelf

Model No.	Dimensions W" x D"	Capacity lbs.	Wt. lbs.	Price /Each
RK552	36 x 12	630	8	18.50
RK553	42 x 12	480	9	23.50
RK554	48 x 12	315	10.5	27.70
RK555	36 x 15	630	9.75	23.00
RK556	42 x 15	480	11.5	28.00
RK557	48 x 15	315	12.5	32.90
RK558	36 x 18	630	11.5	25.40
RK559	42 x 18	480	13	31.20
RK560	48 x 18	315	15	36.40
RK561	36 x 24	630	14.75	32.90
RK562	42 x 24	480	16.5	39.60
RK563	48 x 24	315	19	46.20
RK564	36 x 30	560	18	43.60



**RK552**  
Shelves



**RK470**  
Back panel

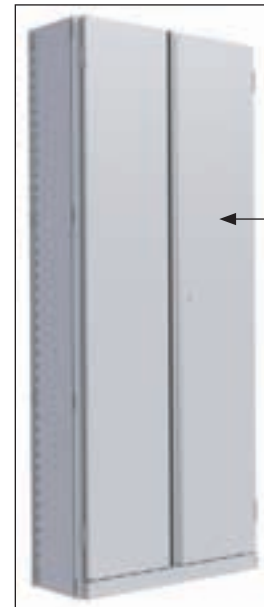

**RN028**  
Doors

## DOORS

- Lockable swinging doors installs easily on closed style shelving
- Includes RN032 base plate

Model No.	Dimensions W x H	Wt. lbs	Price /Each
RN028	36" x 6'4"	43	460.00
RN029	36" x 7'4"	50	465.00
RN032*	Replacement Base Plate	2	7.71

\*Only for units with doors

## BASE PLATES

- Install at floor level to close openings
- Not compatible when installing doors

Model No.	Dimensions W x H	Wt. lbs	Price /Each
RK483	36 x 3	2	7.60
RK484	42 x 3	2.25	8.79
RK485	48 x 3	2.5	9.34

## END PANELS

- For closed style shelving
- Each panel incorporates two slotted post

Model No.	Dimensions D x H	Wt. lbs	Price /Each
RK521	12" x 3'4"	10.5	36.20
RK522	12" x 6'4"	20.75	63.80
RK523	12" x 7'4"	23.5	66.40
RK520	12" x 8'4"	26.25	75.60
RK525	15" x 3'4"	11.5	41.40
RK526	15" x 6'4"	22.5	73.30
RK527	15" x 7'4"	25.5	75.60
RK524	15" x 8'4"	28.5	88.80
RK537	18" x 6'4"	24	75.60
RK538	18" x 7'4"	27	79.30
RK519	18" x 8'4"	30.5	91.90
RK529	24" x 3'4"	14	49.70
RK530	24" x 6'4"	27	87.40
RK531	24" x 7'4"	31	91.50
RK528	24" x 8'4"	34.5	105.00
RK532	30" x 8'4"	38.75	121.00

## BACK PANELS

- For closed style shelving
- Attach easily to end panels using back brackets provided

Model No.	Dimensions W x H	Wt. lbs	Price /Each
RK470	36" x 6'4"	19	58.70
RK471	36" x 7'4"	22	63.70
RK460	36" x 8'4"	25	68.60
RK465	42" x 7'4"	25.5	88.30
RK462	42" x 8'4"	29	86.80
RK947	48" x 3'4"	13.5	41.30
RK468	48" x 6'4"	25.5	82.60
RK469	48" x 7'4"	29.5	95.20
RK466	48" x 8'4"	33.5	106.00

## SIDE & BACK BRACES

- Provide stability to open style shelving units
- Sold in pairs

Model No.	Description	Wt. lbs	Price /Each
RK472	Back Brace	4	17.40
RK565	Side Brace	2	11.00





**RK503**  
Dividers



**RK540**  
Label Holders

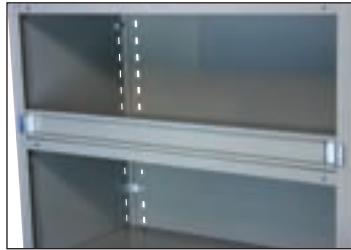
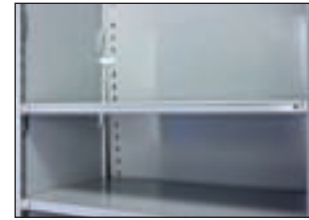

**RK475**  
Bin Front



**RK566**  
Shelf Boxes



**RC453**  
Gusset



**RL756**  
48" Hanger Bar



**RK949**  
Foot Plate

## DIVIDERS

- Separate shelves into bin compartments
- Constructed of 20 gauge steel

Model No.	Dimensions			Wt. lbs	Price /Each
	D"	x	H"		
RK503	12	x	6	0.5	6.01
RK504	15	x	6	0.75	6.13
RK505	18	x	6	1	6.39
RK506	24	x	6	1.5	7.60
RK507	12	x	8	0.75	6.39
RK508	15	x	8	1	6.80
RK509	18	x	8	1.5	7.22
RK510	24	x	8	2	9.48
RK487	12	x	10	1	7.22
RK488	15	x	10	1.25	7.60
RK489	18	x	10	1.75	8.54
RK490	24	x	10	2.25	10.50
RK491	12	x	12	1.25	7.87
RK492	15	x	12	1.75	8.54
RK493	18	x	12	2	9.48
RK494	24	x	12	2.75	12.20
RK495	12	x	14	1.5	8.54
RK496	15	x	14	2	9.61
RK497	18	x	14	2.25	10.50
RK498	24	x	14	3.25	13.70
RK499	18	x	16	2.5	12.80
RK500	18	x	18	2.75	17.10

## LABEL HOLDERS

- Install on shelf front to identify contents of shelves

Model No.	Width"	Wt. lbs.	Price /Each
RK540	36	0.3	4.92
RK542	48	0.3	6.26

## SHELF BOXES

- Slide onto properly spaced shelving
- Extends 100% without spills
- Constructed of 20 gauge steel

Model No.	Dimensions				Wt. lbs	Price /Each	
	W"	x	D"	x	H"		
RK566	5 5/8	x	12	x	2 3/4	2.5	26.10
RK569	5 5/8	x	18	x	2 3/4	3.5	29.20
RK570	5 5/8	x	12	x	4 3/4	3.5	27.20
RK572	5 5/8	x	15	x	4 3/4	4	25.10
RK573	5 5/8	x	18	x	4 3/4	4.5	30.60
RK574	11	x	18	x	4 3/4	5	51.80
RK571	12	x	12	x	4 3/4	5.5	46.20

## BIN FRONTS

- Used in conjunction with bin dividers

Model No.	Dimensions			Wt. lbs	Price /Each
	W"	x	H"		
RK475	36	x	1	1.75	8.27
RK477	36	x	2	2	9.21
RK479	36	x	3	2.25	10.00
RK476	42	x	1	2	9.34
RK478	42	x	2	2.25	10.40
RK480	42	x	3	2.5	11.60

## MISCELLANEOUS

Model No.	Description	Wt. lbs	Price /Each
RK949	Foot Plate	0.3	4.00
RC453	Gusset (Pairs)	1	9.48
RL756*	48" Hanger Bar	3.5	18.10
RL757	24" Hanging Bar Bracket	0.05	16.70
RC515	Shelf Clip	0.01	0.54
RC382	Back to Back Brackets	0.01	1.07
RC505	Back Panel Clip	0.2	1.05

\*Requires two brackets (RL757)

# RACKING/SHELVING

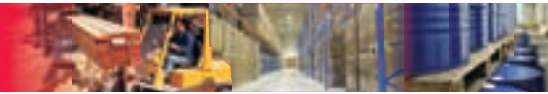

## BOLTLESS SHELVING UNITS

- Adjustable shelving system that provides high strength, yet economical storage capacity for your needs
- This system uses an innovative shelf clip, which slips into a slotted "T" post and is immediate ready to receive a shelf
- No-Bolt design reduces up to 80% of installation time
- Colour: Grey
- Ships knocked down

**METALWARE**  
STEEL SHELVING  
corporation

36" W X 6'4" H



4 SHELVES

Starter Unit	Depth"	Price /Each
RK205	12	176.00
RK207	18	201.00
RK209	24	228.00

Add-On Unit	Depth"	Price /Each
RK204	12	130.00
RK206	18	154.00
RK208	24	181.00

36" W X 6'4" H



7 SHELVES

Starter Unit	Depth"	Price /Each
RK217	12	226.00
RK219	18	269.00
RK221	24	317.00

Add-On Unit	Depth"	Price /Each
RK216	12	179.00
RK218	18	222.00
RK220	24	269.00

36" W X 6'4" H



10 SHELVES

Starter Unit	Depth"	Price /Each
RK229	12	275.00
RK231	18	338.00
RK233	24	405.00

Add-On Unit	Depth"	Price /Each
RK228	12	228.00
RK230	18	291.00
RK232	24	358.00

36" W X 6'4" H



13 SHELVES

Starter Unit	Depth"	Price /Each
RK241	12	361.00
RK243	18	406.00
RK245	24	493.00

Add-On Unit	Depth"	Price /Each
RK240	12	278.00
RK242	18	360.00
RK244	24	447.00

36" W X 7'4" H



4 SHELVES

Starter Unit	Depth"	Price /Each
RK309	12	204.00
RK311	18	231.00
RK313	24	261.00

Add-On Unit	Depth"	Price /Each
RK308	12	148.00
RK310	18	175.00
RK312	24	205.00

36" W X 7'4" H



7 SHELVES

Starter Unit	Depth"	Price /Each
RK333	12	258.00
RK335	18	308.00
RK337	24	360.00

Add-On Unit	Depth"	Price /Each
RK332	12	203.00
RK334	18	251.00
RK336	24	304.00

36" W X 7'4" H



8 SHELVES

Starter Unit	Depth"	Price /Each
RK321	12	249.00
RK323	18	299.00
RK325	24	353.00

Add-On Unit	Depth"	Price /Each
RK320	12	199.00
RK322	18	249.00
RK324	24	303.00

36" W X 7'4" H



15 SHELVES

Starter Unit	Depth"	Price /Each
RK345	12	366.00
RK347	18	459.00
RK349	24	560.00

Add-On Unit	Depth"	Price /Each
RK344	12	315.00
RK346	18	409.00
RK348	24	510.00

48" W X 7'4" H



4 SHELVES

Starter Unit	Depth"	Price /Each
RK285	12	241.00
RK287	18	276.00
RK289	24	315.00

Add-On Unit	Depth"	Price /Each
RK284	12	185.00
RK286	18	220.00
RK288	24	258.00

48" W X 7'4" H



7 SHELVES

Starter Unit	Depth"	Price /Each
RK297	12	324.00
RK299	18	387.00
RK301	24	453.00

Add-On Unit	Depth"	Price /Each
RK296	12	268.00
RK298	18	331.00
RK300	24	397.00

36" W X 8'4" H



5 SHELVES

Starter Unit	Depth"	Price /Each
RK425	12	215.00
RK427	18	246.00
RK429	24	279.00

Add-On Unit	Depth"	Price /Each
RK424	12	157.00
RK426	18	188.00
RK428	24	222.00

36" W X 8'4" H



9 SHELVES

Starter Unit	Depth"	Price /Each
RK401	12	281.00
RK403	18	337.00
RK405	24	398.00

Add-On Unit	Depth"	Price /Each
RK400	12	229.00
RK402	18	273.00
RK404	24	340.00

## BOLTLESS SHELVING UNITS

- Adjustable shelving system that provides high strength, yet economical storage capacity for your needs
- This system uses an innovative shelf clip, which slips into a slotted "T" post and is immediate ready to receive a shelf
- No-Bolt design reduces up to 80% of installation time
- Colour: Grey
- Ships knocked down



36" W X 6'4" H



4 SHELVES

Starter Unit	Depth"	Price /Each
RK211	12	246.00
RK213	18	292.00
RK215	24	341.00

Add-On Unit	Depth"	Price /Each
RK210	12	189.00
RK212	18	225.00
RK214	24	262.00

36" W X 6'4" H



7 SHELVES

Starter Unit	Depth"	Price /Each
RK223	12	296.00
RK225	18	361.00
RK227	24	429.00

Add-On Unit	Depth"	Price /Each
RK222	12	239.00
RK224	18	293.00
RK226	24	351.00

36" W X 6'4" H



10 SHELVES

Starter Unit	Depth"	Price /Each
RK235	12	346.00
RK237	18	429.00
RK239	24	518.00

Add-On Unit	Depth"	Price /Each
RK234	12	288.00
RK236	18	362.00
RK238	24	439.00

36" W X 7'4" H



4 SHELVES

Starter Unit	Depth"	Price /Each
RK315	12	286.00
RK317	18	340.00
RK319	24	394.00

Add-On Unit	Depth"	Price /Each
RK314	12	220.00
RK316	18	260.00
RK318	24	303.00

36" W X 7'4" H



7 SHELVES

Starter Unit	Depth"	Price /Each
RK339	12	342.00
RK341	18	416.00
RK343	24	492.00

Add-On Unit	Depth"	Price /Each
RK338	12	275.00
RK340	18	337.00
RK342	24	401.00

36" W X 7'4" H



8 SHELVES

Starter Unit	Depth"	Price /Each
RK327	12	324.00
RK329	18	397.00
RK331	24	472.00

Add-On Unit	Depth"	Price /Each
RK326	12	264.00
RK328	18	326.00
RK330	24	390.00

36" W X 7'4" H



15 SHELVES

Starter Unit	Depth"	Price /Each
RK351	12	440.00
RK353	18	557.00
RK355	24	679.00

Add-On Unit	Depth"	Price /Each
RK350	12	380.00
RK352	18	485.00
RK354	24	597.00

48" W X 7'4" H



4 SHELVES

Starter Unit	Depth"	Price /Each
RK291	12	354.00
RK293	18	415.00
RK295	24	477.00

Add-On Unit	Depth"	Price /Each
RK290	12	287.00
RK292	18	336.00
RK294	24	386.00

48" W X 7'4" H



7 SHELVES

Starter Unit	Depth"	Price /Each
RK303	12	437.00
RK305	18	525.00
RK307	24	616.00

Add-On Unit	Depth"	Price /Each
RK302	12	371.00
RK304	18	446.00
RK306	24	525.00

36" W X 8'4" H



5 SHELVES

Starter Unit	Depth"	Price /Each
RK431	12	294.00
RK433	18	356.00
RK435	24	410.00

Add-On Unit	Depth"	Price /Each
RK430	12	227.00
RK432	18	272.00
RK434	24	317.00

36" W X 8'4" H



9 SHELVES

Starter Unit	Depth"	Price /Each
RK407	12	361.00
RK409	18	446.00
RK411	24	529.00

Add-On Unit	Depth"	Price /Each
RK406	12	293.00
RK408	18	364.00
RK410	24	435.00

36" W X 8'4" H



13 SHELVES

Starter Unit	Depth"	Price /Each
RK419	12	427.00
RK421	18	538.00
RK423	24	646.00

Add-On Unit	Depth"	Price /Each
RK418	12	360.00
RK420	18	455.00
RK422	24	553.00



# RACKING/SHELVING

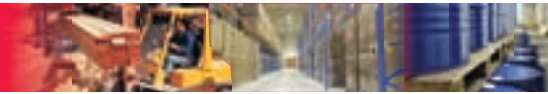

## BOLTLESS SHELVING UNITS

- Adjustable shelving system that provides high strength, yet economical storage capacity for your needs
- This system uses an innovative shelf clip, which slips into a slotted "T" post and is immediate ready to receive a shelf
- No-Bolt design reduces up to 80% of installation time
- Colour: Grey
- Ships knocked down



36" W X 6'4" H



4 SHELVES W/DOORS

Starter Unit	Depth"	Price /Each
RK849	12	654.00
RK850	18	700.00
RK851	24	749.00

Add-On Unit	Depth"	Price /Each
RK852	12	597.00
RK853	18	632.00
RK854	24	670.00

36" W X 7'4" H



4 SHELVES W/ DOORS

Starter Unit	Depth"	Price /Each
RK893	12	748.00
RK894	18	801.00
RK895	24	855.00

Add-On Unit	Depth"	Price /Each
RK896	12	681.00
RK897	18	722.00
RK898	24	764.00

36" W X 6'4" H



7 SHELVES W/DOORS

Starter Unit	Depth"	Price /Each
RK855	12	705.00
RK856	18	769.00
RK857	24	837.00

Add-On Unit	Depth"	Price /Each
RK858	12	647.00
RL013	18	701.00
RL015	24	761.00

36" W X 7'4" H



7 SHELVES W/DOORS

Starter Unit	Depth"	Price /Each
RK899	12	803.00
RK900	18	877.00
RK989	24	954.00

Add-On Unit	Depth"	Price /Each
RK902	12	737.00
RK903	18	798.00
RK904	24	862.00

36" W X 7'4" H



10 COMPARTMENTS W/DOORS

Starter Unit	Depth"	Price /Each
RK911	12	735.00
RK912	18	795.00
RK913	24	865.00

Add-On Unit	Depth"	Price /Each
RK914	12	674.00
RK915	18	724.00
RK916	24	784.00

36" W X 7'4" H



21 COMPARTMENTS W/DOORS

Starter Unit	Depth"	Price /Each
RK921	12	838.00
RK922	18	932.00
RK923	24	1041.00

Add-On Unit	Depth"	Price /Each
RK924	12	779.00
RK925	18	860.00
RK926	24	959.00

36" W X 6'4" H



14 COMPARTMENTS

Starter Unit	Depth"	Price /Each
RK259	12	353.00
RK261	18	429.00
RK263	24	517.00

Add-On Unit	Depth"	Price /Each
RK258	12	295.00
RK260	18	361.00
RK262	24	438.00

36" W X 6'4" H



18 COMPARTMENTS

Starter Unit	Depth"	Price /Each
RK265	12	381.00
RK267	18	463.00
RK269	24	561.00

Add-On Unit	Depth"	Price /Each
RK264	12	324.00
RK266	18	395.00
RK268	24	482.00

36" W X 6'4" H



72 COMPARTMENTS W/BIN FRONTS

Starter Unit	Depth"	Price /Each
RK271	12	793.00
RK273	18	915.00
RK275	24	1085.00

Add-On Unit	Depth"	Price /Each
RK270	12	789.00
RK272	18	846.00
RK274	24	1005.00

36" W X 7'4" H



14 COMPARTMENTS

Starter Unit	Depth"	Price /Each
RK363	12	369.00
RK365	18	449.00
RK367	24	541.00

Add-On Unit	Depth"	Price /Each
RK362	12	310.00
RK364	18	378.00
RK366	24	458.00

36" W X 7'4" H



21 COMPARTMENTS

Starter Unit	Depth"	Price /Each
RK369	12	423.00
RK371	18	506.00
RK373	24	625.00

Add-On Unit	Depth"	Price /Each
RK368	12	364.00
RK370	18	445.00
RK372	24	544.00

36" W X 7'4" H



84 COMPARTMENTS

Starter Unit	Depth"	Price /Each
RK905	12	818.00
RK906	18	960.00
RK907	24	1159.00

Add-On Unit	Depth"	Price /Each
RK908	12	759.00
RK909	18	888.00
RK910	24	1076.00

## BOLTLESS SHELVING UNITS

- Adjustable shelving system that provides high strength, yet economical storage capacity for your needs
- This system uses an innovative shelf clip, which slips into a slotted "T" post and is immediate ready to receive a shelf
- No-Bolt design reduces up to 80% of installation time
- Colour: Grey
- Ships knocked down



36" W X 7'4" H



36" W X 8'4" H



36" W X 6'4" H



36" W X 6'4" H



36" W X 6'4" H



36" W X 6'4" H

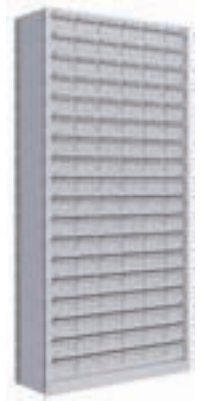

84 COMPARTMENTS  
W/BIN FRONTS

Starter Unit	Depth"	Price /Each
RK383	12	923.00
RK385	18	1064.00
RK387	24	1262.00

Add-On Unit	Depth"	Price /Each
RK382	12	862.00
RK384	18	993.00
RK386	24	1180.00

24 COMPARTMENTS

Starter Unit	Depth"	Price /Each
RK443	12	474.00
RK445	18	583.00
RK447	24	704.00

Add-On Unit	Depth"	Price /Each
RK442	12	406.00
RK444	18	500.00
RK446	24	602.00

36 BOXES

Starter Unit	Depth"	Price /Each
RK277	12	1891.00
RK886	18	2175.00

Add-On Unit	Depth"	Price /Each
RK276	12	1833.00
RK983	18	2106.00

57 BOXES

Starter Unit	Depth"	Price /Each
RK986	12	1891.00
RK890	18	2175.00

Add-On Unit	Depth"	Price /Each
RK891	12	1833.00
RK987	18	2106.00

72 BOXES

Starter Unit	Depth"	Price /Each
RK877	12	1893.00
RK878	18	2175.00

Add-On Unit	Depth"	Price /Each
RK879	12	1833.00
RK880	18	2106.00

108 BOXES

Starter Unit	Depth"	Price /Each
RK980	12	2647.00
RK982	18	3033.00

Add-On Unit	Depth"	Price /Each
RK979	12	2590.00
RK981	18	2966.00

36" W X 7'4" H



36" W X 7'4" H



36" W X 7'4" H



36" W X 7'4" H



36" W X 6'4" H



36" W X 7'4" H

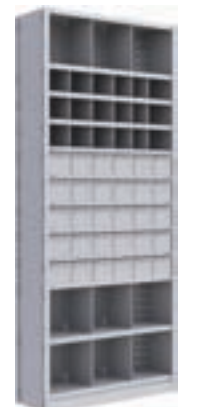

42 BOXES

Starter Unit	Depth"	Price /Each
RK935	12	2427.00
RK936	18	2792.00

Add-On Unit	Depth"	Price /Each
RK937	12	2361.00
RK938	18	2713.00

69 BOXES

Starter Unit	Depth"	Price /Each
RK939	12	2427.00
RK940	18	2792.00

Add-On Unit	Depth"	Price /Each
RK941	12	2361.00
RK942	18	2713.00

84 BOXES

Starter Unit	Depth"	Price /Each
RK927	12	2185.00
RK928	18	2513.00

Add-On Unit	Depth"	Price /Each
RK929	12	2125.00
RK930	18	2441.00

126 BOXES

Starter Unit	Depth"	Price /Each
RK931	12	3408.00
RK932	18	3905.00

Add-On Unit	Depth"	Price /Each
RK933	12	3341.00
RK934	18	3826.00

24 COMPARTMENTS  
& 30 BOXES

Starter Unit	Depth"	Price /Each
RK970	12	1136.00
RK868	18	1312.00

Add-On Unit	Depth"	Price /Each
RK969	12	1078.00
RK971	18	1244.00

27 COMPARTMENTS  
& 30 BOXES

Starter Unit	Depth"	Price /Each
RK917	12	1184.00
RK918	18	1372.00

Add-On Unit	Depth"	Price /Each
RK919	12	1125.00
RK920	18	1300.00

# RACKING/SHELVING

## INTEGRATED SHELVING DRAWER INSERTS

### FOR METALWARE SHELVING

- Integrated drawer inserts allow you to install directly into your existing or new Metalware shelving units.
- The system maximizes the storage space available in your shelving unit and reduces the need for additional shelving for storage of small parts
- Drawer dividers included
- Drawer capacity: 400 lbs.
- Colour: Grey

**LISTA**

making workspace work®



### OVERALL HEIGHT: 24"

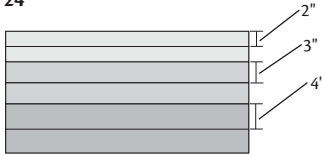

#### 6 DRAWERS

Model No.	Dimensions			Number of Compartments	Price /Each
	D"	x	W"		
RL760	24	x	36	102	1800.00
RL759	24	x	42	114	1984.00
RL758	24	x	48	144	2472.00

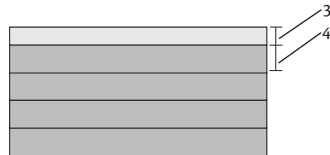

#### 5 DRAWERS

Model No.	Dimensions			Number of Compartments	Price /Each
	D"	x	W"		
RL763	24	x	36	75	1839.00
RL762	24	x	42	90	2058.00
RL761	24	x	48	108	2595.00

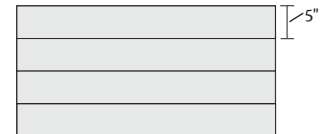

#### 4 DRAWERS

Model No.	Dimensions			Number of Compartments	Price /Each
	D"	x	W"		
RL766	24	x	36	48	1390.00
RL765	24	x	42	48	1468.00
RL764	24	x	48	72	1861.00

### OVERALL HEIGHT: 36"

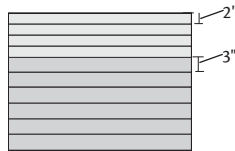

#### 10 DRAWERS

Model No.	Dimensions			Number of Compartments	Price /Each
	D"	x	W"		
RL769	24	x	36	174	2809.00
RL768	24	x	42	192	3123.00
RL767	24	x	48	252	3955.00



#### 9 DRAWERS

Model No.	Dimensions			Number of Compartments	Price /Each
	D"	x	W"		
RL772	24	x	36	174	2602.00
RL771	24	x	42	192	2847.00
RL770	24	x	48	252	3612.00

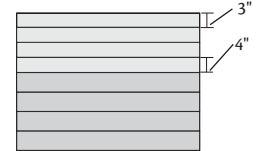

#### 8 DRAWERS

Model No.	Dimensions			Number of Compartments	Price /Each
	D"	x	W"		
RL775	24	x	36	120	2420.00
RL774	24	x	42	144	2689.00
RL773	24	x	48	180	3362.00

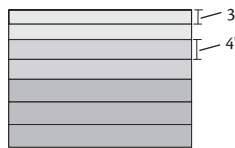

#### 7 DRAWERS

Model No.	Dimensions			Number of Compartments	Price /Each
	D"	x	W"		
RL778	24	x	36	96	2209.00
RL777	24	x	42	108	2402.00
RL776	24	x	48	144	3033.00

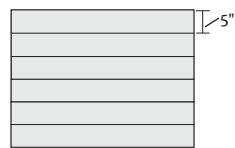

#### 6 DRAWERS

Model No.	Dimensions			Number of Compartments	Price /Each
	D"	x	W"		
RL781	24	x	36	72	1997.00
RL780	24	x	42	72	2115.00
RL779	24	x	48	108	2705.00

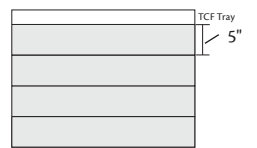

#### 5 DRAWERS

Model No.	Dimensions			Number of Compartments	Price /Each
	D"	x	W"		
RL784	24	x	36	48	2466.00
RL783	24	x	42	48	2740.00
RL782	24	x	48	72	3425.00

TCF Tray is an open face roll-out tray

Other colours available upon request



## INTEGRATED SHELVING DRAWER INSERTS (CONT'D)



OVERALL HEIGHT: 48"

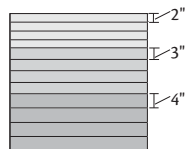

12 DRAWERS

Model No.	Dimensions			Number of Compartments	Price /Each
	D"	x	W"		
RL787	24	x	36	204	3425.00
RL786	24	x	42	228	3793.00
RL785	24	x	48	204	4770.00

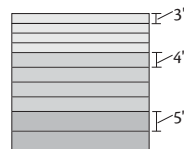

10 DRAWERS

Model No.	Dimensions			Number of Compartments	Price /Each
	D"	x	W"		
RL790	24	x	36	144	3028.00
RL789	24	x	42	168	3336.00
RL788	24	x	48	216	4205.00

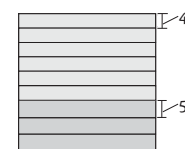

9 DRAWERS

Model No.	Dimensions			Number of Compartments	Price /Each
	D"	x	W"		
RL793	24	x	36	126	2824.00
RL792	24	x	42	144	3071.00
RL791	24	x	48	180	3848.00

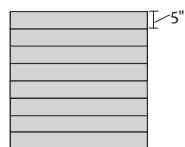

8 DRAWERS

Model No.	Dimensions			Number of Compartments	Price /Each
	D"	x	W"		
RL796	24	x	36	96	2605.00
RL795	24	x	42	96	2761.00
RL794	24	x	48	144	3548.00

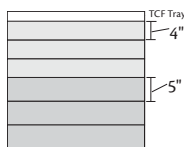

7 DRAWERS

Model No.	Dimensions			Number of Compartments	Price /Each
	D"	x	W"		
RL799	24	x	36	90	2198.00
RL798	24	x	42	108	2364.00
RL797	24	x	48	135	2967.00

TCF Tray is an open face roll-out tray

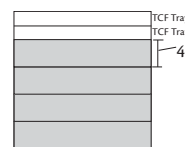

6 DRAWERS

Model No.	Dimensions			Number of Compartments	Price /Each
	D"	x	W"		
RL802	24	x	36	48	1876.00
RL801	24	x	42	48	1981.00
RL800	24	x	48	72	2509.00

TCF Trays are open face roll-out trays

Other colours available upon request

For our complete line of Hand Tools, see pages 1276 to 1385



# WIRE SHELVING

## CHROMATE WIRE SHELVING

- Heavy-gauge chromate plated shelves with open wire design minimize dust, improve air circulation and provide greater visibility of stored items
- Post's circular grooves combined with tapered plastic split sleeves allow for assembly in minutes with no special tools
- Shelf ribs run front to back allowing items to slide on and off shelves smoothly
- Shelves can be adjusted at precise 1" intervals
- Posts are double grooved every 8" and numbered for easy adjustment
- Adjustable feet compensate for surface irregularities
- Stationary unit's total capacity should not exceed 2000 lbs.
- NSF certified
- Assembly required

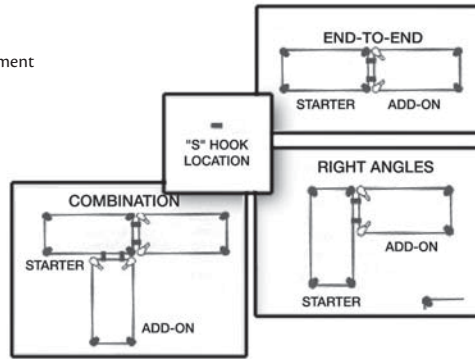

**Kleton wire shelving can be assembled as you wish: End to End, at Right Angles or any combination.**

### 4 SHELVES

Model No.	Type	Dimensions W" x D" x H"	Cap. lbs /Shelf*	Wt. lbs.	Price /Each
<b>63" POSTS</b>					
RL907	Starter	30 x 14 x 63	800	39	169.00
RL908	Add-on	30 x 14 x 63	800	32	143.00
RL632	Starter	36 x 14 x 63	800	43	189.00
RL633	Add-on	36 x 14 x 63	800	35.5	166.00
RL634	Starter	48 x 14 x 63	800	49	211.00
RL635	Add-on	48 x 14 x 63	800	42	189.00
RL636	Starter	60 x 14 x 63	600	64.75	230.00
RL637	Add-on	60 x 14 x 63	600	57.75	207.00
RL638	Starter	72 x 14 x 63	600	71.5	254.00
RL639	Add-on	72 x 14 x 63	600	64	228.00
RL059	Starter	36 x 18 x 63	800	48	223.00
RL060	Add-on	36 x 18 x 63	800	35	189.00
RL061	Starter	48 x 18 x 63	800	58	252.00
RL062	Add-on	48 x 18 x 63	800	53.5	214.00
RL063	Starter	60 x 18 x 63	600	81	302.00
RL064	Add-on	60 x 18 x 63	600	76.5	269.00
RL065	Starter	72 x 18 x 63	600	91	348.00
RL066	Add-on	72 x 18 x 63	600	86.5	306.00
RL067	Starter	36 x 24 x 63	800	62	238.00
RL068	Add-on	36 x 24 x 63	800	57.5	205.00
RL069	Starter	48 x 24 x 63	800	74	302.00
RL070	Add-on	48 x 24 x 63	800	69.5	269.00
RL071	Starter	60 x 24 x 63	600	95	348.00
RL072	Add-on	60 x 24 x 63	600	90.5	317.00
RL073	Starter	72 x 24 x 63	600	117	430.00
RL074	Add-on	72 x 24 x 63	600	112.5	396.00

\* Evenly distributed weight

### 5 SHELVES

Model No.	Type	Dimensions W" x D" x H"	Cap. lbs /Shelf*	Wt. lbs.	Price /Each
<b>74" POSTS</b>					
RL909	Starter	30 x 14 x 74	800	46.5	206.00
RL910	Add-on	30 x 14 x 74	800	39	173.00
RL640	Starter	36 x 14 x 74	800	51	223.00
RL641	Add-on	36 x 14 x 74	800	44	189.00
RL642	Starter	48 x 14 x 74	800	59	240.00
RL643	Add-on	48 x 14 x 74	800	42.8	238.00
RL644	Starter	60 x 14 x 74	600	78.75	265.00
RL645	Add-on	60 x 14 x 74	600	71	261.00
RL646	Starter	72 x 14 x 74	600	87	312.00
RL647	Add-on	72 x 14 x 74	600	79.5	280.00
RL075	Starter	36 x 18 x 74	800	67.75	238.00
RL076	Add-on	36 x 18 x 74	800	58.25	226.00
RL077	Starter	48 x 18 x 74	800	80.25	253.00
RL078	Add-on	48 x 18 x 74	800	70.75	246.00
RL079	Starter	60 x 18 x 74	600	109	317.00
RL080	Add-on	60 x 18 x 74	600	99.5	287.00
RL081	Starter	72 x 18 x 74	600	121.5	366.00
RL082	Add-on	72 x 18 x 74	600	112	336.00
RL083	Starter	36 x 24 x 74	800	85.25	257.00
RL084	Add-on	36 x 24 x 74	800	75.75	249.00
RL085	Starter	48 x 24 x 74	800	100.25	309.00
RL086	Add-on	48 x 24 x 74	800	90.75	299.00
RL087	Starter	60 x 24 x 74	600	126.5	365.00
RL088	Add-on	60 x 24 x 74	600	117	347.00
RL089	Starter	72 x 24 x 74	600	154	445.00
RL090	Add-on	72 x 24 x 74	600	144.5	411.00
<b>86" POSTS</b>					
RL448	Starter	36 x 18 x 86	800	62	253.00
RL449	Add-on	36 x 18 x 86	800	53	232.00
RL450	Starter	48 x 18 x 86	800	69	286.00
RL451	Add-on	48 x 18 x 86	800	60	263.00
RL452	Starter	60 x 18 x 86	600	91.5	333.00
RL453	Add-on	60 x 18 x 86	600	82	303.00
RL454	Starter	72 x 18 x 86	600	96	382.00
RL455	Add-on	72 x 18 x 86	600	87	352.00
RL456	Starter	36 x 24 x 86	800	74	269.00
RL457	Add-on	36 x 24 x 86	800	65	261.00
RL458	Starter	48 x 24 x 86	800	90	333.00
RL459	Add-on	48 x 24 x 86	800	80	303.00
RL460	Starter	60 x 24 x 86	600	107	565.00
RL461	Add-on	60 x 24 x 86	600	97	536.00
RL462	Starter	72 x 24 x 86	600	129	596.00
RL463	Add-on	72 x 24 x 86	600	120	547.00

\* Evenly distributed weight

## WIRE SHELVING COMPONENTS

- Heavy-gauge chromate plated shelves with open wire design minimize dust, improve air circulation and provide greater visibility of stored items
- Post's circular grooves combined with tapered plastic split sleeves allow for assembly in minutes with no special tools
- Shelf ribs run front to back allowing items to slide on and off shelves smoothly
- Shelves can be adjusted at precise 1" intervals
- Posts are double grooved every 8" and numbered for easy adjustment
- Adjustable feet compensate for surface irregularities
- Stationary unit's total capacity should not exceed 2000 lbs.
- NSF certified
- Assembly required

## WIRE SHELVES

Model No.	Dimensions W" x D"	Cap lbs.*	Wt. lbs.	Price /Each
RL606	30 x 14	800	7.5	34.30
RL607	36 x 14	800	8.25	34.95
RL608	48 x 14	800	10.5	42.00
RL609	60 x 14	600	14.25	46.85
RL610	72 x 14	600	17.5	53.20
RL035	30 x 18	800	8.5	40.80
RL036	36 x 18	800	9.75	43.85
RL037	48 x 18	800	12.5	52.85
RL038	60 x 18	600	18	65.95
RL039	72 x 18	600	20.5	76.30
RL040	36 x 24	800	13.25	47.95
RL041	48 x 24	800	16.25	64.25
RL042	60 x 24	600	21.5	76.90
RL043	72 x 24	600	27	90.70

\* Evenly distributed weight

## POSTS

Model No.	Height"	Wt. lbs.	Price /Each
RL611	33	4	14.05
RL330	54	6.3	17.10
RL331	63	7	17.85
RL332	74	8	20.25
RL333	86	8.8	23.25



## ACCESSORIES



RL048



RL049



RL050 Divider



RL054 Split Sleeve



RL055 "S" Hook

Use S hooks to eliminate two posts per adjacent shelf. Two required per shelf.



RL056 Leveling Foot



RL614 Ledge for Shelf



RL330 Posts

Model No.	Description	Wt. lbs.	Price /Each
RL048	Caster, 5", no brake	2.8	27.40
RL049	Caster, 5", with brake	2.7	28.85
RL050	Divider for shelf, 18"	1.7	15.50
RL051	Divider for shelf, 24"	2.2	18.90
RL052	Handle 18" - For utility carts	3.9	30.75
RL053	Handle 24" - For utility carts	4.4	31.65

Model No.	Description	Wt. lbs.	Price /Each
RL054	Split Sleeves, black 4 Pc/bag	0.1	5.45
RL055	S-Hook for attaching Add-On	0.1	4.60
RL056	Leveling feet (Die cast and foot bolt)	0.2	4.15
RL057	Die cast for leveling feet	0.1	1.85
RL058	Foot bolt for leveling feet	0.1	2.40

Model No.	Description	Wt. lbs.	Price /Each
RL614	Ledge for shelf, 14"	0.6	11.70
RL615	Ledge for shelf, 18"	0.75	12.35
RL616	Ledge for shelf, 24"	1	14.45
RL617	Ledge for shelf, 30"	2	17.55
RL618	Ledge for shelf, 36"	2.5	19.10
RL619	Ledge for shelf, 48"	3.5	22.90
RL620	Ledge for shelf, 60"	3.75	24.20
RL621	Ledge for shelf, 72"	4	30.70

## DIRECT WALL MOUNTS FOR WIRE SHELVING

SAME GREAT FEATURES AS THE KLETON CHROMATE WIRE SHELVING, BUT WITH THE ADDED CONVENIENCE OF DIRECTLY MOUNTING ON A WALL

- Each wall mount unit consists of one shelf support and mounting plate
- Use single support at shelf ends; double support for adjoining shelves
- Installation note: Wall mounts must be securely fastened to materials of adequate load bearing strength. (Load rating: 200 lbs. (91kg) per system)

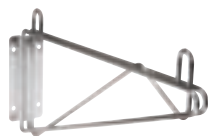

RL612  
Single Shelf Support



RL613  
Double Shelf Support



Model No.	Shelf Support	Shelf Depth"	Price /Each
RL612	Single	14	39.40
RL898	Single	18	46.00
RL900	Single	24	47.95
RL613	Double	14	59.30
RL899	Double	18	68.95
RL901	Double	24	71.80

## WALL MOUNT WIRE SHELVING KITS

- Kit includes shelves and supports



RL911  
Shelf and Support Kit



Model No.	Description	Shelf Dimensions"	Price /Each
RL911	1 Shelf	30 x 14	105.00
RL912	2 Shelves	30 x 14	195.00



# WIRE SHELVING

## WIRE SHELVING UNITS WITH STORAGE BINS

Same great features as the Kleton chromate wire shelving, but with the added convenience of heavy-duty storage bins.

- Adjustable chromate wire shelves
- Wire shelving resists corrosion and provides greater visibility to stored parts
- Wire shelves prevent build up of dust and dirt
- Bins are unaffected by oil, alkaline, and most acids
- Ideal in production or for parts storage
- NSE certified
- Assembly required
- Unit's total capacity should not exceed 2000-lb.



RL815



RL820



RL826



RL837

Model No.	Shelving Size			No. of Shelves	Bin Size			No. of Bins	Colour	Price /Each
	W" x D" x H"	W"	x D" x H"							
RL815	36 x 14 x 74	8	83/16 x 14 x 63/16	28	Blue	594.00				
RL816	36 x 14 x 74	8	83/16 x 14 x 63/16	28	Yellow	594.00				
RL817	36 x 14 x 74	8	83/16 x 14 x 63/16	28	Green	594.00				
RL818	36 x 14 x 74	8	83/16 x 14 x 63/16	28	Red	594.00				
RL819	36 x 18 x 74	8	77/8 x 17 11/16 x 7	28	Blue	854.00				
RL820	36 x 18 x 74	8	77/8 x 17 11/16 x 7	28	Yellow	854.00				
RL821	36 x 18 x 74	8	77/8 x 17 11/16 x 7	28	Green	854.00				
RL822	36 x 18 x 74	8	77/8 x 17 11/16 x 7	28	Red	854.00				
RL823	36 x 24 x 74	5	15 1/2 x 25 x 13	8	Blue	618.00				
RL824	36 x 24 x 74	5	15 1/2 x 25 x 13	8	Yellow	618.00				
RL825	36 x 24 x 74	5	15 1/2 x 25 x 13	8	Green	618.00				
RL826	36 x 24 x 74	5	15 1/2 x 25 x 13	8	Red	618.00				
RL827	48 x 18 x 74	8	77/8 x 17 11/16 x 7 11 13/16 x 17 11/16 x 7	28 7	Blue Blue	1061.00				
RL828	48 x 18 x 74	8	77/8 x 17 11/16 x 7 11 13/16 x 17 11/16 x 7	28 7	Yellow Yellow	1061.00				
RL829	48 x 18 x 74	8	77/8 x 17 11/16 x 7 11 13/16 x 17 11/16 x 7	28 7	Green Green	1061.00				
RL830	48 x 18 x 74	8	77/8 x 17 11/16 x 7 11 13/16 x 17 11/16 x 7	28 7	Red Red	1061.00				
RL831	48 x 18 x 74	8	77/8 x 17 11/16 x 7 11 13/16 x 17 11/16 x 7	7 21	Blue Blue	990.00				
RL832	48 x 18 x 74	8	77/8 x 17 11/16 x 7 11 13/16 x 17 11/16 x 7	7 21	Yellow Yellow	990.00				
RL833	48 x 18 x 74	8	77/8 x 17 11/16 x 7 11 13/16 x 17 11/16 x 7	7 21	Green Green	990.00				
RL834	48 x 18 x 74	8	77/8 x 17 11/16 x 7 11 13/16 x 17 11/16 x 7	7 21	Red Red	990.00				
RL835	48 x 24 x 74	5	77/8 x 17 11/16 x 7 11 13/16 x 17 11/16 x 7 15 1/2 x 25 x 13	4 7 6	Blue Blue Blue	777.00				
RL836	48 x 24 x 74	5	77/8 x 17 11/16 x 7 11 13/16 x 17 11/16 x 7 15 1/2 x 25 x 13	4 7 6	Yellow Yellow Yellow	777.00				
RL837	48 x 24 x 74	5	77/8 x 17 11/16 x 7 11 13/16 x 17 11/16 x 7 15 1/2 x 25 x 13	4 7 6	Green Green Green	777.00				
RL838	48 x 24 x 74	5	77/8 x 17 11/16 x 7 11 13/16 x 17 11/16 x 7 15 1/2 x 25 x 13	4 7 6	Red Red Red	777.00				
RL839	36 x 18 x 74	8	77/8 x 17 11/16 x 7 11 13/16 x 17 11/16 x 7	7 14	Blue Blue	830.00				
RL840	36 x 18 x 74	8	77/8 x 17 11/16 x 7 11 13/16 x 17 11/16 x 7	7 14	Yellow Yellow	830.00				
RL841	36 x 18 x 74	8	77/8 x 17 11/16 x 7 11 13/16 x 17 11/16 x 7	7 14	Green Green	830.00				
RL842	36 x 18 x 74	8	77/8 x 17 11/16 x 7 11 13/16 x 17 11/16 x 7	7 14	Red Red	830.00				

## WIRE-RAC™

- Snap on holders easily and quickly identify stored contents
- Clear, flexible plastic sleeves fit new or existing wire shelving with 1 1/4" facing; paper inserts included
- ON767 snaps onto wire shelf at 3 different angles; 90° (flat), 60° or 30°
- 25 per box

Model No.	Dimensions			Price /Each
	W"	x	L"	
RH683	15/16	x	3	31.50
RH684	15/16	x	6	55.60
RH685	15/16	x	12	49.20
RH686	15/16	x	24	51.10
ON767	1 1/4	x	3	51.80



## GREEN EPOXY FINISH WIRE SHELVING

- Ideal for use in wet environments
- Superior rust resistance
- Designed to minimize dust, improve air circulation, and provide greater visibility of stored items
- Post's circular grooves combined with tapered plastic sleeves allow for assembly in minutes with no special tools
- Shelf ribs run front to back allowing items to slide on and off shelves smoothly
- Shelves can be adjusted at precise 1" intervals
- Posts are double grooved every 8" and numbered for easy adjustment
- Adjustable feet compensate for surface irregularities
- Stationary unit's total capacity should not exceed 2000 lbs.
- NSF certified



### POSTS

Model No.	Height"	Price/Each
RL629	63	16.15
RL630	74	18.25
RL631	86	20.90

### WIRE SHELVES

Model No.	Dimensions W" x D"	Cap lbs. /Shelf*	Price /Each
RL622	36 x 18	800	39.25
RL623	48 x 18	800	46.95
RL624	60 x 18	600	55.40
RL625	72 x 18	600	65.15
RL626	36 x 24	800	48.35
RL627	48 x 24	800	58.90
RL628	60 x 24	600	70.00
RN077	72 x 24	600	81.70

\* Evenly distributed weight



### COMPLETE SHELVING UNITS

Model No.	Type	Dimensions W" x D" x H"	Cap lbs. /Shelf*	Price /Each
<b>4 SHELVES</b>				
RL648	Starter	36 x 18 x 63	800	207.00
RL649	Add-on	36 x 18 x 63	800	192.00
RL650	Starter	48 x 18 x 63	800	236.00
RL651	Add-on	48 x 18 x 63	800	221.00
RL652	Starter	60 x 18 x 63	600	266.00
RL653	Add-on	60 x 18 x 63	600	255.00
RL654	Starter	72 x 18 x 63	600	304.00
RL655	Add-on	72 x 18 x 63	600	290.00
RL656	Starter	36 x 24 x 63	800	241.00
RL657	Add-on	36 x 24 x 63	800	233.00
RL658	Starter	48 x 24 x 63	800	279.00
RL659	Add-on	48 x 24 x 63	800	266.00
RL660	Starter	60 x 24 x 63	600	319.00
RL661	Add-on	60 x 24 x 63	600	309.00
<b>5 SHELVES</b>				
RL662	Starter	36 x 18 x 74	800	252.00
RL663	Add-on	36 x 18 x 74	800	242.00
RL664	Starter	48 x 18 x 74	800	288.00
RL665	Add-on	48 x 18 x 74	800	278.00
RL666	Starter	60 x 18 x 74	600	325.00
RL667	Add-on	60 x 18 x 74	600	316.00
RL668	Starter	72 x 18 x 74	600	372.00
RL669	Add-on	72 x 18 x 74	600	363.00
RL670	Starter	36 x 24 x 74	800	309.00
RL671	Add-on	36 x 24 x 74	800	299.00
RL672	Starter	48 x 24 x 74	800	342.00
RL673	Add-on	48 x 24 x 74	800	334.00
RL674	Starter	60 x 24 x 74	600	416.00
RL675	Add-on	60 x 24 x 74	600	406.00

\* Evenly distributed weight

## GREEN EPOXY FINISH WIRE SHELF CARTS

- Green epoxy wire shelf carts are ideal for use in wet environments
- Superior rust resistance
- Designed to minimize dust, improve air circulation, and provide greater visibility of stored items
- Shelves can be adjusted quickly and easily
- Strong and versatile
- Capacity: 600 lbs. evenly distributed
- Includes: 5" resilient rubber casters, two swivel, two with brake
- NSF certified
- One year limited warranty
- Shipped knocked down



Model No.	Dimensions W" x D" x H"	Wt. lbs.	Price /Each
<b>4 SHELVES</b>			
RL803	18 x 36 x 74	64	337.00
RL804	18 x 48 x 74	74	368.00
RL805	18 x 60 x 74	94	403.00
RL806	24 x 36 x 74	78	372.00
RL807	24 x 48 x 74	90	412.00
RL808	24 x 60 x 74	110	460.00
<b>5 SHELVES</b>			
RL809	18 x 36 x 86	68	385.00
RL810	18 x 48 x 86	78	424.00
RL811	18 x 60 x 86	98	466.00
RL812	24 x 36 x 86	82	430.00
RL813	24 x 48 x 86	94	498.00
RL814	24 x 60 x 86	114	551.00

## WIRE-RAC™

- Snap on holders easily and quickly identify stored contents
- Clear, flexible plastic sleeves fit new or existing wire shelving with 1 1/4" facing; paper inserts included
- **ON767** snaps onto wire shelf at 3 different angles; 90° (flat), 60° or 30°
- 25 per box



Model No.	Dimensions W" x L"	Price /Each
RH683	1 5/16 x 3	31.50
RH684	1 5/16 x 6	55.60
RH685	1 5/16 x 12	49.20
RH686	1 5/16 x 24	51.10
ON767	1 1/4 x 3	51.80

# WIRE SHELVING

## SUPER ADJUSTABLE SUPER ERECTA SHELF®

- **Super Adjustable Super Erecta® Wire Shelving™** is the most advanced and innovative wire storage system available
- Super Adjustable Shelving works in conjunction with the entire Super Erecta™ System of shelves and accessories
- **Easily Adjustable:** Unique Corner Release and SiteSelect™ Posts, create a total system that offers tool-free, fast and easy adjustment at 1" (25 mm) intervals along the entire height of posts
- **Easily Assembled:** The Corner Release System and SiteSelect™ Posts, combined with the original bottom up assembly process, creates a complete shelving system in minutes
- SiteSelect™ Posts with the triple-groove visual guide feature, have circular grooves at 1" intervals and are numbered at 2" intervals
- Shelves simply snap into place using the Corner Release
- **Unique Shelf Design:** The open wire design of these heavy-gauge shelves minimizes dust accumulation and allows a free circulation of air, greater visibility of stored items and greater light penetration
- Shelf ribs run front to back allowing you to slide items on and off easily
- Shelves can be loaded and unloaded from all sides
- **Unique Post Design:** New SiteSelect™ post design provides a visual guide for positioning and adjusting shelves, saving considerable time during assembly and adjustment
- An easy-to-identify triple groove, every 8 inches, offers a quick way to align all shelves
- Bolt leveller on post bottom compensates for uneven surface
- **Fast, Easy Reconfiguration:** Super Adjustable Super Erecta Shelf® can change as quickly as your needs change
- By using various accessories available, hundreds of shelving configurations become possible
- **Choice of Finishes:** Super Adjustable Super Erecta Shelf® Wire Shelving™ is available in two options: Chrome-plated for dry storage and Metroseal III™ for corrosive environments
- Microban® antimicrobial product protection helps keep products cleaner and fresher by inhibiting the growth of bacteria, mold, mildew and fungi that cause stains and odours
- Microban® is safe, clean, fresh and effective, and provides peace of mind!



Super Adjustable Super Erecta® Chrome Shelving								Super Adjustable Super Erecta® Metroseal III™ Shelving											
Dimensions				No. of Shelves	Starter Model No.	Price /Each	Add-on Model No.	Price /Each	Dimensions				No. of Shelves	Starter Model No.	Price /Each	Add-on Model No.	Price /Each		
W"	x	D"	x						W"	x	D"	x							
36	x	18	x	62 9/16	4	RL464	339.00	RL465	302.00	36	x	18	x	62 9/16	4	RL512	382.00	RL513	340.00
48	x	18	x	62 9/16	4	RL466	390.00	RL467	353.00	48	x	18	x	62 9/16	4	RL514	465.00	RL515	421.00
60	x	18	x	62 9/16	4	RL468	436.00	RL469	399.00	60	x	18	x	62 9/16	4	RL516	495.00	RL517	450.00
72	x	18	x	62 9/16	4	RL470	506.00	RL471	469.00	72	x	18	x	62 9/16	4	RL518	549.00	RL519	504.00
36	x	18	x	74 5/8	5	RL480	410.00	RL481	371.00	36	x	18	x	74 5/8	5	RL528	462.00	RL529	416.00
48	x	18	x	74 5/8	5	RL482	474.00	RL483	435.00	48	x	18	x	74 5/8	5	RL530	566.00	RL531	519.00
60	x	18	x	74 5/8	5	RL484	532.00	RL485	493.00	60	x	18	x	74 5/8	5	RL532	603.00	RL533	556.00
72	x	18	x	74 5/8	5	RL486	618.00	RL487	580.00	72	x	18	x	74 5/8	5	RL534	670.00	RL535	623.00
36	x	18	x	86 5/8	5	RL496	433.00	RL497	383.00	36	x	18	x	86 5/8	5	RL544	479.00	RL545	424.00
48	x	18	x	86 5/8	5	RL498	497.00	RL499	447.00	48	x	18	x	86 5/8	5	RL546	583.00	RL547	527.00
60	x	18	x	86 5/8	5	RL500	555.00	RL501	505.00	60	x	18	x	86 5/8	5	RL548	619.00	RL549	564.00
72	x	18	x	86 5/8	5	RL502	642.00	RL503	591.00	72	x	18	x	86 5/8	5	RL550	687.00	RL551	632.00
36	x	24	x	62 9/16	4	RL472	406.00	RL473	369.00	36	x	24	x	62 9/16	4	RL520	438.00	RL521	393.00
48	x	24	x	62 9/16	4	RL474	458.00	RL475	421.00	48	x	24	x	62 9/16	4	RL522	510.00	RL523	465.00
60	x	24	x	62 9/16	4	RL476	523.00	RL477	486.00	60	x	24	x	62 9/16	4	RL524	583.00	RL525	538.00
72	x	24	x	62 9/16	4	RL478	605.00	RL479	568.00	72	x	24	x	62 9/16	4	RL526	714.00	RL527	670.00
36	x	24	x	74 5/8	5	RL488	494.00	RL489	455.00	36	x	24	x	74 5/8	5	RL536	532.00	RL537	485.00
48	x	24	x	74 5/8	5	RL490	558.00	RL491	520.00	48	x	24	x	74 5/8	5	RL538	621.00	RL539	574.00
60	x	24	x	74 5/8	5	RL492	641.00	RL493	602.00	60	x	24	x	74 5/8	5	RL540	713.00	RL541	666.00
72	x	24	x	74 5/8	5	RL494	743.00	RL495	704.00	72	x	24	x	74 5/8	5	RL542	877.00	RL543	830.00
36	x	24	x	86 5/8	5	RL504	517.00	RL505	467.00	36	x	24	x	86 5/8	5	RL552	548.00	RL553	493.00
48	x	24	x	86 5/8	5	RL506	582.00	RL507	531.00	48	x	24	x	86 5/8	5	RL554	638.00	RL555	583.00
60	x	24	x	86 5/8	5	RL508	664.00	RL509	614.00	60	x	24	x	86 5/8	5	RL556	729.00	RL557	674.00
72	x	24	x	86 5/8	5	RL510	766.00	RL511	716.00	72	x	24	x	86 5/8	5	RL558	894.00	RL559	839.00



## METROMAX I® STORAGE SYSTEMS

- The most versatile storage system ever introduced
- Open shelf mats are easy to remove for cleaning
- Solid shelf mats, dividers, ledges, drop-in wire baskets, and an array of accessories, can easily be added or removed in seconds
- Completely Mobile** with the addition of 5" casters
- Strong and Durable:** Reinforced polymers give MetroMax I® incredible strength; 800 lbs. per shelf up to 42" in length and 600 lbs. per shelf up to 72" in length Also, shelves won't mark or crease
- Corrosion and Rust Proof:** MetroMax I® has a lifetime warranty against corrosion and rust, so it's perfect for damp, humid conditions as well as dry storage
- Fast, Easy Assembly:** MetroMax I® assembles easily in minutes, without tools
- Posts have numbered grooves at 1" increments, with 1/2" increment adjustment
- Wedge lock connectors, with window and pointer to locate desired post groove, snap onto posts
- Simply attach the wedge lock connectors at the desired post height and lower the shelf into place
- With unit complete, solid shelf and open-grid mats can be removed and/or interchanged at any time



**Microban® antimicrobial product protection helps keep products cleaner and fresher by inhibiting the growth of bacteria, mold, mildew and fungi that cause stains and odors.**

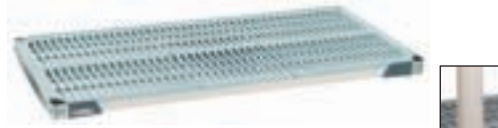

### METROMAX I® SHELVES\*

Shelf Size W" x L"	Open Grid Model No.	Wt. lbs.	Price /Each	Solid Shelf Model No.	Wt. lbs.	Price /Each
18 x 24	RC538	9	162.00	RC537	11	179.00
18 x 30	RC540	11	169.00	RC539	12	187.00
18 x 36	RC542	12	169.00	RC541	14	187.00
18 x 42	RC549	14	203.00	RC548	16	230.00
18 x 48	RC551	15	203.00	RC550	18	230.00
18 x 54	RC558	17	242.00	RC557	20	268.00
18 x 60	RC560	18	242.00	RC559	22	268.00
18 x 72	RC561	18	283.00	-	-	-
24 x 24	RC563	11	202.00	RC562	13	222.00
24 x 30	RC565	13	205.00	RC564	15	227.00
24 x 36	RC567	14	205.00	RC566	17	232.00
24 x 42	RC569	16	245.00	RC568	19	284.00
24 x 48	RC571	18	250.00	RC570	22	277.00
24 x 54	RC573	20	290.00	RC572	24	327.00
24 x 60	RC575	22	290.00	RC574	26	327.00

\* Shelf c/w frame, mat and wedge lock connectors.

## CANTILEVER SHELVES

- Add convenient shelving space above a storage unit
- Drop mat design creates a retaining edge around the entire 12" deep shelf
- Standard Super Erecta® posts available separately
- Can also be used as an extension to an already mounted shelf for additional space
- Also available in the following colours: smoked glass, white and a wide assortment of designer colours



Length"	Wt. lbs.	Model No.		Price /Each
		Chrome	Black	
24	4 1/2	RH347	RH353	53.00
30	5	RH348	RH354	55.10
36	5 3/4	RH349	RH355	57.30
42	6 3/4	RH350	RH356	61.50
48	7 3/4	RH351	RH357	66.90
60	9 1/2	RH352	RH358	77.30



Height"	Wt. lbs.	Model No.		Price /Each
		Chrome	Black	
34 1/2	2	RC827	RH293	17.80
54 1/2	3	RC850	RH294	19.40
62 1/2	3 1/2	RC895	RG797	20.60
74 5/8	4	RC924	RG798	22.30
86 1/2	5	RC932	RG799	28.50

## WALL MOUNT WIRE SHELVING KITS

- Kit includes shelves and supports

Model No.	Description	Shelf Dimensions"	Price /Each
RL911	1 Shelf	14 x 30	105.00
RL912	2 Shelves	14 x 30	195.00



## DIRECT WALL MOUNTS FOR WIRE SHELVING

SAME GREAT FEATURES AS THE KLETON CHROMATE WIRE SHELVING, BUT WITH THE ADDED CONVENIENCE OF DIRECTLY MOUNTING ON A WALL.

- Each wall mount unit consists of one shelf support and mounting plate
- Use single support at shelf ends; double support for adjoining shelves
- Installation note: Wall mounts must be securely fastened to materials of adequate load bearing strength. (Load rating: 200 lbs. (91kg) per system )



RL612  
Single Shelf Support



RL613  
Double Shelf Support

Model No.	Shelf Support	Shelf Depth"	Price /Each
RL612	Single	14	39.40
RL898	Single	18	46.00
RL900	Single	24	47.95
RL613	Double	14	59.30
RL899	Double	18	68.95
RL901	Double	24	71.80



# WIRE SHELVING

## UTILITY CARTS

- Durable, dependable transport solution that is easy to manoeuvre
- Highly rigid construction that is easily adjustable at 1" increments
- Two handles, indicated number of shelves, and casters
- Capacity: 600 lbs. evenly distributed
- Shipped knocked down
- NSF certified
- **One-year limited warranty**



MJ543



Model No.	Dimensions W" x D" x H"	Wt. lbs.	Price /Each
<b>2 SHELVES</b>			
MK781	30 x 18 x 39	36.5	219.00
MK782	36 x 18 x 39	40.25	223.00
MK783	48 x 18 x 39	44.75	235.00
MK784	60 x 18 x 39	54	290.00
MK785	36 x 24 x 39	47.75	252.00
MK786	48 x 24 x 39	53.75	275.00
MK787	60 x 24 x 39	63.5	304.00
<b>3 SHELVES</b>			
MJ539	30 x 18 x 39	45	250.00
MJ540	36 x 18 x 39	50	262.00
MJ541	48 x 18 x 39	57	276.00
MJ542	60 x 18 x 39	72	318.00
MJ543	36 x 24 x 39	61	279.00
MJ544	48 x 24 x 39	70	304.00
MJ545	60 x 24 x 39	85	338.00

## PUSH CARTS

- Durable, dependable transport solution
- Easy maneuverability
- Shelves can be adjusted quickly and easily
- Capacity: 600 lbs. evenly distributed
- Shipped knocked down
- NSF certified
- **One-year limited warranty**



RL915



Model No.	Dimensions W" x D" x H"	Price /Each
<b>4 SHELVES</b>		
RL914	30 x 14 x 54	214.00
RL915	36 x 14 x 54	293.00
RL916	48 x 14 x 54	324.00
RL917	60 x 14 x 54	346.00
<b>5 SHELVES</b>		
RL918	30 x 14 x 54	236.00
RL919	36 x 14 x 54	328.00
RL920	48 x 14 x 54	378.00
RL921	60 x 14 x 54	401.00

## WIRE SHELF CARTS

- Open-wire shelf design minimizes dust and increases air circulation and visibility
- High quality chromate shelves and posts prevent corrosion
- Shelves can be adjusted quickly and easily
- Strong and versatile
- Includes: 5" resilient rubber casters (two swivel, two with brake)
- Capacity: 600 lbs. evenly distributed
- Shipped knocked down
- NSF certified
- **One-year limited warranty**



Model No.	Dimensions W" x D" x H"	Wt. lbs.	Price /Each
<b>4 SHELVES</b>			
RL600	36 x 18 x 63	56	317.00
RL601	48 x 18 x 63	65	344.00
RL602	60 x 18 x 63	83	378.00
RL603	36 x 24 x 63	69	330.00
RL604	48 x 24 x 63	81	390.00
RL605	60 x 24 x 63	95	436.00
MJ527	36 x 18 x 74	64	328.00
MJ528	48 x 18 x 74	74	356.00
MJ529	60 x 18 x 74	94	391.00
MJ530	36 x 24 x 74	78	342.00
MJ531	48 x 24 x 74	90	404.00
MJ532	60 x 24 x 74	110	451.00
<b>5 SHELVES</b>			
MJ533	36 x 18 x 86	68	367.00
MJ534	48 x 18 x 86	78	422.00
MJ535	60 x 18 x 86	98	464.00
MJ536	36 x 24 x 86	82	395.00
MJ537	48 x 24 x 86	94	456.00
MJ538	60 x 24 x 86	114	499.00



MJ533

## GREEN EPOXY WIRE SHELF CARTS

- Green epoxy wire shelf carts are ideal for use in wet environments
- Superior rust resistance
- Designed to minimize dust, improve air circulation, and provide greater visibility of stored items
- Shelves can be adjusted quickly and easily
- Strong and versatile
- Includes: 5" resilient rubber casters (two swivel, two with brake)
- Capacity: 600 lbs. evenly distributed
- Shipped knocked down
- **One-year limited warranty**



Model No.	Dimensions W" x D" x H"	Wt. lbs.	Price /Each
<b>4 SHELVES</b>			
RL803	36 x 18 x 74	64	337.00
RL804	48 x 18 x 74	74	368.00
RL805	60 x 18 x 74	94	403.00
RL806	36 x 24 x 74	78	372.00
RL807	48 x 24 x 74	90	412.00
RL808	60 x 24 x 74	110	460.00
<b>5 SHELVES</b>			
RL809	36 x 18 x 86	68	385.00
RL810	48 x 18 x 86	78	424.00
RL811	60 x 18 x 86	98	466.00
RL812	36 x 24 x 86	82	435.00
RL813	48 x 24 x 86	94	498.00
RL814	60 x 24 x 86	114	551.00



RL803

## SECURITY CARTS

- Security carts are ideal for safety storing and transporting of valuable goods
- Open wire construction allows for visibility into the unit so items can be checked at any time
- Double door design that allows for each door to open 270 degrees and can be secured along the side
- Shipped knocked-down



RL408



RL399



Model No	Overall Dimensions				No. of Shelves	Price /Each
	W"	x	D"	x H"		
<b>STATIONARY</b>						
RL399	38.5	x	21.5	x 66 13/16	4	1216.00
RL400	50.5	x	21.5	x 66 13/16	4	1502.00
RL402	38.5	x	21.5	x 66 13/16	5	1280.00
RL403	50.5	x	21.5	x 66 13/16	5	1579.00
<b>MOBILE</b>						
RL408	38.5	x	21.5	x 68 1/2	4	1169.00
RL409	50.5	x	21.5	x 68 1/2	4	1399.00
RL411	38.5	x	21.5	x 68 1/2	5	1249.00
RL412	50.5	x	21.5	x 68 1/2	5	1469.00

## STAINLESS STEEL STANDARD-DUTY UTILITY CARTS

- Durable dependable and easy to manoeuvre carts with extended handles
- Highly rigid Super Erecta® construction lets you easily adjust shelves at 1" increments
- Weight capacity is 375 lbs.
- Shipped knocked down



RG452



Model No.	Dimensions				No. of Shelves	Wt. lbs.	Price /Each
	W"	x	L"	x H"			
<b>WITH WIRE SHELVES</b>							
RG444	18	x	24	x 39	2	34	549.00
RG445	18	x	30	x 39	2	37	629.00
RG446	18	x	36	x 39	2	39	626.00
RG447	24	x	36	x 39	2	46	739.00
RG448	18	x	24	x 39	3	38	744.00
RG449	18	x	30	x 39	3	42	823.00
RG450	18	x	36	x 39	3	45	823.00
RG451	24	x	36	x 39	3	57	989.00
<b>WITH SOLID SHELVES</b>							
RG452	18	x	24	x 39	2	40	595.00
RG453	18	x	30	x 39	2	45	673.00
RG454	18	x	36	x 39	2	48	679.00
RG455	24	x	36	x 39	2	60	769.00
RG456	18	x	24	x 39	3	48	795.00
RG457	18	x	30	x 39	3	53	878.00
RG458	18	x	36	x 39	3	59	878.00
RG459	24	x	36	x 39	3	74	1019.00

Note: 18" wide carts have 4" light duty swivel casters and 24" wide carts have 5" light duty swivel casters.

## COVERS FOR SHELF TRUCKS & CARTS

- Protect contents from dust and other air-borne contaminants
  - Covers deter pilferage and allow units to be loaded prior to transport
  - Available in either uncoated nylon or coated waterproof vinyl, with an aluminum zippered closure
  - Colour: White.
- Please note:** Axll covers are non-returnable



RG460



Nylon Size L" x H"	Uncoated Model No.	Price /Each	Vinyl Coated Model No.	Price /Each
<b>FOR SHELF TRUCKS AND CARTS 18" WIDE</b>				
36 x 54	RG460	169.00	RG466	286.00
36 x 62	RG461	179.00	RG467	295.00
48 x 54	RG462	189.00	RG468	299.00
48 x 62	RG463	188.00	RG469	309.00
60 x 54	RG464	193.00	RG470	322.00
60 x 62	RG465	194.00	RG471	328.00
<b>FOR SHELF TRUCKS AND CARTS 24" WIDE</b>				
36 x 54	RG472	192.00	RG478	295.00
36 x 62	RG473	199.00	RG479	309.00
48 x 54	RG474	208.00	RG480	348.00
48 x 62	RG475	244.00	RG481	359.00
60 x 54	RG476	277.00	RG482	387.00
60 x 62	RG477	286.00	RG483	399.00

Note: Other colours available.

## HEAVY-DUTY UTILITY CARTS

- Carts consist of two or three wire shelves with plastic split sleeves, two one-piece handles and donut bumpers
- Available with 5" resilient rubber casters or 5" poly casters



MB515



Chromate Model No.	Shelf Size W" x L"	No. of Shelves	Wt. lbs.	Price /Each
<b>WITH POLY CASTERS (WEIGHT CAPACITY: 900 LBS.)</b>				
MB515	18 x 36	2	41	359.00
MB533	18 x 36	3	51	409.00
MB525	24 x 36	2	49	389.00
MB543	24 x 36	3	63	459.00
MB529	24 x 48	2	55	414.00
MB547	24 x 48	3	71	495.00
MB531	24 x 60	2	65	443.00
MB549	24 x 60	3	71	538.00



# WIRE SHELVING

## STAINLESS STEEL SOLID RIVET SHELVING

- High quality stainless steel solid shelving made of type 304 stainless steel construction with brushed finish
- 18-gauge thick shelves adjustable in 1 1/2" increments
- Two-piece corner posts design includes plastic connectors
- **Includes:** Five adjustable shelves with a capacity of 600 lbs. per shelf
- Shipped knocked down, easy assembly

Model No.	Mfg. No.	Dimensions				Cap Lbs. /Shelf	Price /Each
		W"	x	D"	x H"		
RL853	LWSS-1836	36	x	18	x 72	600	1069.00
RL854	LWSS-1848	48	x	18	x 72	600	1329.00
RL855	LWSS-2436	36	x	24	x 72	600	1295.00
RL856	LWSS-2448	48	x	24	x 72	600	1487.00



## WELDED FRAME TIRE RACKS

- Ideal solution for all sizes of tires
- No nuts or bolts required for assembly
- Shelves can be loaded and are accessible from both the front and the back
- Easily adjustable on 2" increments
- Consists of 2 welded frames and 3 pairs of 2" front mount step beams

RN068



Model No	Rack Type	Tire Capacity	Dimensions				Wt. lbs.	Price /Each
			W"	x	D"	x H"		
RN068	Starter	21	60	x	18	x 72	111	302.00
RN069	Starter	27	72	x	18	x 72	123	332.00
RN070	Starter	36	96	x	18	x 72	147	377.00
RN071	Add-on	21	60	x	18	x 72	90	241.00
RN072	Add-on	27	72	x	18	x 72	102	272.00
RN073	Add-on	36	96	x	18	x 72	126	312.00

## E-Z GLIDE ROLL-OUT SHELVING

- Designed for heavy-duty loading and easy retrieval of hard-to-handle items
- Stores up to 2000 lbs. per shelf (evenly distributed)
- Every shelf extends 100%
- Adjustable shelf height based on 2" centres
- 3-shelf models available on the 84 1/2" H units
- Shipped knocked down

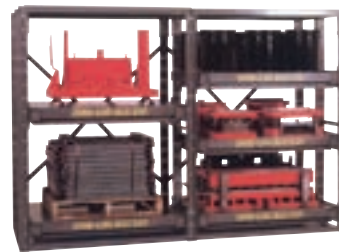

Starter & Add-on



Starter

Shelf Size"	Overall Height"	No. of shelves	Starter Model No.	Wt. lbs.	Price /Each	Add-on Model No.	Wt. lbs	Price /Each	Additional Shelves	Wt. lbs.	Price /Each
36 x 36	62 1/2	3	RK064	911	8891.00	RK073	831	8688.00	RK082	210	2437.00
48 x 36	62 1/2	3	RK065	1053	9379.00	RK074	973	8846.00	RK083	248	2523.00
48 x 48	62 1/2	3	RK066	1260	10159.00	RK075	1174	9188.00	RK084	303	2751.00
36 x 36	72 1/2	3	RK067	932	8894.00	RK076	842	8358.00	RK082	210	2437.00
48 x 36	72 1/2	3	RK068	1074	9383.00	RK077	984	8847.00	RK083	248	2523.00
48 x 48	72 1/2	3	RK069	1281	10162.00	RK078	1185	9622.00	RK084	303	2751.00
36 x 36	84 1/2	4	RK070	1166	11379.00	RK079	1063	11187.00	RK082	210	2437.00
48 x 36	84 1/2	4	RK071	1348	12052.00	RK080	1245	11427.00	RK083	248	2523.00
48 x 48	84 1/2	4	RK072	1510	13088.00	RK081	1501	12450.00	RK084	303	2751.00

## HEAVY-DUTY REEL RACKS

- Ideal for storing or dispensing wire, rope, chain and hose
- Provides quick and uncluttered access to reels
- 24" maximum reel dimension
- Comes standard with four sets of rack axle brackets, adjustable on 2" centers, that accept axels up to 2" diameter
- Capacity: 2000 lbs. per level with 10 000-lb. maximum capacity per rack
- **Axels (support rods for wire spools) and wire spools are not included**

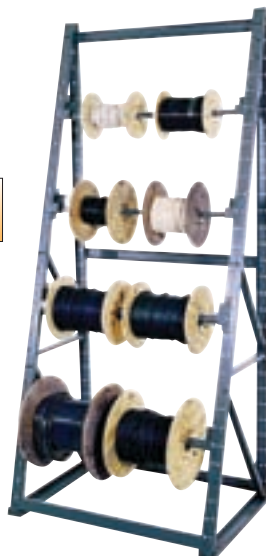

### ACCESSORIES

Model No.	Description	Wt. lbs.	Price /Each
MK968	Extra Set of Axle Brackets	7	195.00

Recommended that unit be secured to floor for stability (Anchors not included).

Model No.	Unit Type	Dimensions				Wt. lbs.	Price /Each
		W"	x	D"	x H"		
MK944	Starter	24	x	24	x 96	236	1791.00
MK956	Add-on	24	x	24	x 96	149	1290.00
MK946	Starter	36	x	24	x 96	252	1833.00
MK958	Add-on	36	x	24	x 96	165	1329.00
MK948	Starter	48	x	24	x 96	268	1883.00
MK960	Add-on	48	x	24	x 96	181	1377.00
MK945	Starter	24	x	36	x 96	254	1804.00
MK957	Add-on	24	x	36	x 96	158	1297.00
MK947	Starter	36	x	36	x 96	270	1846.00
MK959	Add-on	36	x	36	x 96	174	1335.00
MK949	Starter	48	x	36	x 96	286	1897.00
MK961	Add-on	48	x	36	x 96	190	1382.00
MK950	Starter	24	x	24	x 120	269	1490.00
MK962	Add-on	24	x	24	x 120	165	1153.00
MK951	Starter	36	x	24	x 120	285	1639.00
MK963	Add-on	36	x	24	x 120	181	1239.00
MK952	Starter	48	x	24	x 120	301	1689.00
MK964	Add-on	48	x	24	x 120	197	1345.00
MK953	Starter	24	x	36	x 120	344	1895.00
MK965	Add-on	24	x	36	x 120	175	1420.00
MK954	Starter	36	x	36	x 120	248	1950.00
MK966	Add-on	36	x	36	x 120	191	1463.00
MK955	Starter	48	x	36	x 120	321	1999.00
MK967	Add-on	48	x	36	x 120	207	1514.00

## PIPE FITTINGS

There are many variations of fittings to suit a wide range of applications, providing the versatility to achieve any structural configuration. Kee Klamp® fittings are galvanized malleable iron castings designed to suit eight sizes of tube. A standard hex key and tube cutters are the only tools required to create strong, rigid structures. Recessed set screws, tightened by the hex key, firmly lock the tube into the fitting. The set screw is manufactured in case hardened steel and is coated to protect against corrosion.



### KEE KLAMP®

- Simple method of constructing tubular structures
- Cost effective alternative to welding
- Galvanized to resist corrosion



**SHORT TEES**

Model No.	Pipe O.D."	Price /Each
RK597	1.05	10.70
RK598	1.315	12.60
RK599	1.66	17.70
RK600	1.90	20.40
RK601	2.375	38.40



**LONG TEES**

Model No.	Pipe O.D."	Price /Each
RK602	1.05	20.10
RK603	1.315	19.10
RK604	1.66	30.00
RK605	1.90	33.10
RK606	2.375	53.10



**SIDE OUTLET TEES**

Model No.	Pipe O.D."	Price /Each
RK607	1.05	15.90
RK608	1.315	16.40
RK609	1.66	23.90
RK610	1.90	27.20
RK611	2.375	50.50



**TWO SOCKET CROSSES**

Model No.	Pipe O.D."	Price /Each
RK612	1.05	16.70
RK613	1.315	19.10
RK614	1.66	23.10
RK615	1.90	30.50
RK616	2.375	51.60



**90° ELBOWS**

Model No.	Pipe O.D."	Price /Each
RK617	1.05	14.60
RK618	1.315	15.60
RK619	1.66	20.60
RK620	1.90	26.90
RK621	2.375	43.90



**ANGLE CROSSES**

Model No.	Pipe O.D."	Price /Each
N/A	1.05	-
RK622	1.315	12.60
RK623	1.66	17.70
N/A	1.90	-
N/A	2.375	-



**ANGLE TEES**

Model No.	Pipe O.D."	Price /Each
N/A	1.05	-
RK625	1.315	58.20
RK626	1.66	66.00
RK627	1.90	75.60
N/A	2.375	-



**3 WAY 90° ELBOWS**

Model No.	Pipe O.D."	Price /Each
RK628	1.05	21.60
RK629	1.315	21.10
RK630	1.66	30.60
RK631	1.90	37.90
N/A	2.375	-



**ADJUSTABLE SHORT TEES**

Model No.	Pipe O.D."	Price /Each
N/A	1.05	-
RK632	1.315	19.80
RK633	1.66	26.60
RK634	1.90	30.10
N/A	2.375	-



**ADJUSTABLE TWO SOCKET CROSSES**

Model No.	Pipe O.D."	Price /Each
N/A	1.05	-
RK635	1.315	32.00
RK636	1.66	42.50
RK637	1.90	48.60
N/A	2.375	-



**BASE FLANGES**

Model No.	Pipe O.D."	Price /Each
RK638	1.05	12.60
RK639	1.315	13.60
RK640	1.66	19.00
RK641	1.90	24.40
RK642	2.375	34.40



**RAILING BASE FLANGES**

Model No.	Pipe O.D."	Price /Each
RK643	1.05	23.60
RK644	1.315	23.50
RK645	1.66	27.10
RK646	1.90	35.00
RK647	2.375	48.00



**PLASTIC END PLUGS**

Model No.	Pipe O.D."	Price /Each
RA179	1.05	0.91
RA180	1.315	1.09
RA181	1.66	1.36
RA182	1.90	1.43
RA183	2.375	1.77



**GROUND SOCKETS**

Model No.	Pipe O.D."	Price /Each
N/A	1.05	-
RK648	1.315	12.60
RK649	1.66	17.70
RK650	1.90	20.40
N/A	2.375	-



**CLAMP-ON TEES**

Model No.	Pipe O.D."	Price /Each
RK651	1.05	28.70
RK652	1.315	30.10
RK653	1.66	35.70
RK654	1.90	41.80
N/A	2.375	-



**GATE EYES**

Model No.	Pipe O.D."	Price /Each
RK655	1.05	11.80
RK656	1.315	12.30
RK657	1.66	13.80
RK658	1.90	15.30
N/A	2.375	-

# BARRIERS & PARTITIONS

## PIPE FITTINGS



**GATE HINGES**

Model No.	Pipe O.D."	Price /Each
RK659	1.05	13.10
RK660	1.315	14.00
RK661	1.66	15.80
RK662	1.90	17.30
N/A	2.375	-



**HANDRAIL BRACKETS**

Model No.	Pipe O.D."	Price /Each
RK663	1.05	17.60
RK664	1.315	17.10
RK665	1.66	22.70
RK666	1.90	28.30
N/A	2.375	-



**VERTICAL RAILING SUPPORTS**

Model No.	Pipe O.D."	Price /Each
N/A	1.05	-
RK667	1.315	39.90
RK668	1.66	52.10
RK669	1.90	20.40
N/A	2.375	-



**HORIZONTAL RAILING SUPPORTS**

Model No.	Pipe O.D."	Price /Each
N/A	1.05	-
RK670	1.315	39.00
N/A	1.66	-
N/A	1.90	-
N/A	2.375	-



**SIDE PALM FIXINGS**

Model No.	Pipe O.D."	Price /Each
N/A	1.05	-
RK671	1.315	27.10
RK672	1.66	27.70
RK673	1.90	30.90
N/A	2.375	-



**INTERNAL SWIVEL TEES**

Model No.	Pipe O.D."	Price /Each
N/A	1.05	-
RK674	1.315	21.70
RK675	1.66	30.30
RK676	1.90	39.00
N/A	2.375	-



**SHORT SWIVEL TEES**

Model No.	Pipe O.D."	Price /Each
RK677	1.05	32.50
RK678	1.315	35.50
RK679	1.66	45.50
RK680	1.90	45.90
N/A	2.375	-



**SLEEVE JOINTS**

Model No.	Pipe O.D."	Price /Each
RK681	1.05	14.00
RK682	1.315	14.20
RK683	1.66	19.20
RK684	1.90	22.00
RK685	2.375	30.70



**INTERNAL JOINTS**

Model No.	Pipe O.D."	Price /Each
N/A	1.05	-
RK686	1.315	15.20
RK687	1.66	20.40
RK688	1.90	29.70
N/A	2.375	-



**4-WAY CROSSES**

Model No.	Pipe O.D."	Price /Each
RK689	1.05	30.70
RK690	1.315	36.10
RK691	1.66	51.40
RK692	1.90	59.60
N/A	2.375	-



**CLAMP-ON CROSSEVERS**

Model No.	Pipe O.D."	Price /Each
RK693	1.05	10.80
RK694	1.315	12.60
RK695	1.66	20.20
RK696	1.90	22.20
N/A	2.375	-



**90° CROSSEVERS**

Model No.	Pipe O.D."	Price /Each
RK697	1.05	17.90
RK698	1.315	15.00
RK699	1.66	20.90
RK700	1.90	24.50
RK701	2.375	36.80



**TEE/CROSSOVER COMBINATIONS**

Model No.	Pipe O.D."	Price /Each
RK702	1.05	20.40
RK703	1.315	20.30
RK704	1.66	25.30
RK705	1.90	39.40
RK706	2.375	58.90



**DOUBLE SWIVELS**

Model No.	Pipe O.D."	Price /Each
RK707	1.05	47.20
RK709	1.315	47.90
RK711	1.66	53.10
RK713	1.90	59.60
RK715	2.375	114.00



**MALE DOUBLE SWIVELS**

Model No.	Pipe O.D."	Price /Each
RK708	1.05	21.40
RK710	1.315	21.80
RK712	1.66	21.80
RK714	1.90	22.30
RK716	2.375	32.90



**MALE CORNER SWIVELS**

Model No.	Pipe O.D."	Price /Each
N/A	1.05	-
RK718	1.315	23.50
RK720	1.66	26.70
RK722	1.90	26.10
N/A	2.375	-



**CORNER SWIVELS**

Model No.	Pipe O.D."	Price /Each
N/A	1.05	-
RK717	1.315	47.30
RK719	1.66	57.80
RK721	1.90	63.40
N/A	2.375	-



**BASE PLATES**

Model No.	Pipe O.D."	Price /Each
RK728	1.05	16.70
N/A	1.315	-
N/A	1.66	-
N/A	1.90	-
N/A	2.375	-

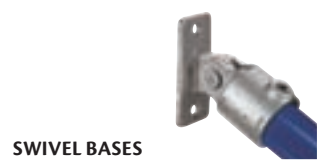

**SWIVEL BASES**

Model No.	Pipe O.D."	Price /Each
RK723	1.05	29.60
RK724	1.315	30.10
RK725	1.66	32.20
RK726	1.90	35.30
RK727	2.375	56.70



**MESH PANEL CLIPS**

Model No.	Pipe O.D."	Price /Each
RK729	1.05	4.81
RK730	1.315	4.81
RK731	1.66	5.59
RK732	1.90	5.59
N/A	2.375	-



## PIPE FITTINGS

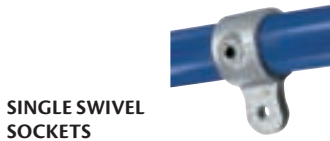

**SINGLE SWIVEL SOCKETS**

Model No.	Pipe O.D."	Price /Each
RK739	1.05	11.30
RK742	1.315	11.40
RK745	1.66	14.10
RK748	1.90	14.50
RK751	2.375	26.60



**FEMALE SWIVEL SOCKETS**

Model No.	Pipe O.D."	Price /Each
RK738	1.05	11.70
RK741	1.315	11.80
RK744	1.66	15.10
RK747	1.90	18.00
RK750	2.375	39.40



**SINGLE SWIVEL COMBINATIONS**

Model No.	Pipe O.D."	Price /Each
RK737	1.05	23.50
RK740	1.315	24.10
RK743	1.66	28.70
RK746	1.90	33.00
RK749	2.375	66.70



**OUTLET TEES**

Model No.	Pipe O.D."	Price /Each
RK752	1.05	19.80
RK753	1.315	23.30
RK754	1.66	34.00
RK755	1.90	36.80
RK756	2.375	77.40



**LOCKING COLLARS**

Model No.	Pipe O.D."	Price /Each
RK757	1.05	8.14
RK758	1.315	9.38
RK759	1.66	12.20
RK760	1.90	11.20
N/A	2.375	-



**HOOKS**

Model No.	Pipe O.D."	Price /Each
N/A	1.05	-
RK761	1.315	9.86
RK821	1.66	13.50
RK763	1.90	14.40
N/A	2.375	-



**EAVES FITTINGS**

Model No.	Pipe O.D."	Price /Each
N/A	1.05	-
N/A	1.315	-
N/A	1.66	-
RA301	1.90	47.40
N/A	2.375	-



**RIDGE FITTINGS**

Model No.	Pipe O.D."	Price /Each
N/A	1.05	-
N/A	1.315	-
N/A	1.66	-
RA302	1.90	40.40
N/A	2.375	-



**WEATHER CAPS**

Model No.	Pipe O.D."	Price /Each
N/A	1.05	-
RK766	1.315	35.90
RK767	1.66	39.60
RK768	1.90	45.60
N/A	2.375	-



**ADJUSTABLE FIXING BRACKETS**

Model No.	Pipe O.D."	Price /Each
N/A	1.05	-
N/A	1.315	-
N/A	1.66	-
RK817	1.90	15.30
N/A	2.375	-

## TOOLS

Model No.	Description	Price /Each
TX413	T-Handle hex key for 1.05", 1.315" and 1.66" pipes	9.12
TX414	T-Handle hex key for 1.90" and 2.375" pipes	13.90



## PIPES

Build an unlimited array of strong rigid structures combining standard black iron (unthreaded) pipe or galvanized (threaded - on one side) pipe (**schedule 40**), with any combination of corresponding sized Kee Klamp® fittings. Pipe sizes are available from 1.05" to 2.375" (outside diameter). Standard pipe length is 21 ft., with cut lengths available upon request. A cutting charge will be added per cut length of piping.

Call for pricing.

Pipe O.D."	Pipe I.D."	Pipe Length'	Black Iron Model No.	Galvanized Iron Model No.
1.05	0.75	21	RA109	RA110
1.215	1	21	RA111	RA112
1.66	1.25	21	RA113	RA114
1.90	1.5	21	RA115	RA116
2.375	2	21	RA117	RA118

Model No. RG259 Cutting charge per cut length  
Price/Each \$5.28



# BARRIERS & PARTITIONS

## GALVANIZED FOLDING SECURITY GATES

- Secure outside access during the day and add security at night with heavy-duty, 14-gauge steel folding gates
- Constructed of galvanized steel U channels riveted using aircraft quality rivets for durability
- With double folding gates center drop pin rests in your pre-drilled holes to secure gate when extended
- Locks can be located on right or left side of single gates
- Durable 2" steel zinc-plated and welded to the frame, rubber casters that fully retract when not in use
- Installation hardware included



**Note:** Middle drop pin not included for models with a useable width of 7' and below

### SINGLE FOLDING GATES

Lock on Left Model No.	Lock on Right Model No.	Usable Width'	Height Collapsed'	Height Expanded'	Wt. lbs.	Price /Each
KA035	KA036	3 to 4	6.5	6	69	362.00
KA037	KA038	3 to 4	7	6.5	73	400.00
KA039	KA040	3 to 4	7.5	7	77	439.00
KA041	KA042	3 to 4	8	7.5	80	477.00
KA043	KA044	3 to 4	8.5	8	84	496.00
KA045	KA046	4 to 5	6.5	6	73	408.00
KA047	KA048	4 to 5	7	6.5	74	450.00
KA049	KA050	4 to 5	7.5	7	78	494.00
KA051	KA052	4 to 5	8	7.5	80	532.00
KA053	KA054	4 to 5	8.5	8	82	554.00
KA055	KA056	5 to 6	6.5	6	76	450.00
KA057	KA058	5 to 6	7	6.5	79	494.00
KA059	KA060	5 to 6	7.5	7	81	532.00
KA061	KA062	5 to 6	8	7.5	84	574.00
KA063	KA064	5 to 6	8.5	8	86	593.00
KA065	KA066	6 to 7	6.5	6	82	458.00
KA067	KA068	6 to 7	7	6.5	85	496.00
KA069	KA070	6 to 7	7.5	7	87	534.00
KA071	KA072	6 to 7	8	7.5	90	570.00
KA073	KA074	6 to 7	8.5	8	92	592.00
KA075	KA076	7 to 8	6.5	6	88	554.00
KA077	KA078	7 to 8	7	6.5	92	593.00
KA079	KA080	7 to 8	7.5	7	96	635.00
KA081	KA082	7 to 8	8	7.5	99	676.00
KA083	KA084	7 to 8	8.5	8	104	716.00
KA085	KA086	8 to 9	7	6.5	102	667.00
KA087	KA088	8 to 9	7.5	7	104	706.00
KA089	KA090	8 to 9	8	7.5	106	742.00
KA031	KA032	9 to 10	7	6.5	109	686.00
KA033	KA034	9 to 10	8	7.5	112	764.00

### DOUBLE FOLDING GATES

Model No.	Usable Width'	Height Collapsed'	Height Expanded'	Wt. lbs.	Price /Each
KA026	6 to 8	6.5	6	120	676.00
KA027	6 to 8	7	6.5	124	737.00
KA028	6 to 8	7.5	7	129	759.00
KA029	6 to 8	8	7.5	134	799.00
KA030	6 to 8	8.5	8	139	821.00
KA001	8 to 10	6.5	6	144	667.00
KA002	8 to 10	7	6.5	148	706.00
KA003	8 to 10	7.5	7	153	742.00
KA004	8 to 10	8	7.5	158	782.00
KA005	8 to 10	8.5	8	162	820.00
KA006	10 to 12	6.5	6	168	715.00
KA007	10 to 12	7	6.5	172	764.00
KA008	10 to 12	7.5	7	177	800.00
KA009	10 to 12	8	7.5	182	876.00
KA010	10 to 12	8.5	8	187	914.00
KA011	12 to 14	6.5	6	180	820.00
KA012	12 to 14	7	6.5	184	858.00
KA013	12 to 14	7.5	7	189	904.00
KA014	12 to 14	8	7.5	196	953.00
KA015	12 to 14	8.5	8	199	999.00
KA016	14 to 16	6.5	6	192	933.00
KA017	14 to 16	7	6.5	196	971.00
KA018	14 to 16	7.5	7	199	1028.00
KA019	14 to 16	8	7.5	201	1107.00
KA020	14 to 16	8.5	8	206	1200.00
KA021	16 to 18	7	6.5	204	1162.00
KA022	16 to 18	7.5	7	208	1259.00
KA023	16 to 18	8	7.5	211	1316.00
KA024	18 to 20	7	6.5	216	1316.00
KA025	18 to 20	8	7.5	230	1506.00

## HEAVY-DUTY DOOR GATES

- Folding door gates can be installed in any doorway up to 48" wide inside or outside the jamb
- Gates pivot on a hinge so that they can open in or out, just like a door
- All folding door gates come with a locking bar that when padlocked provides maximum security
- Frame is constructed from 1 1/2" x 1 1/2", 12-gauge angle iron, zinc-plated
- Channel constructed from 3/8" x 3/4", 14-gauge steel
- Installation hardware not included

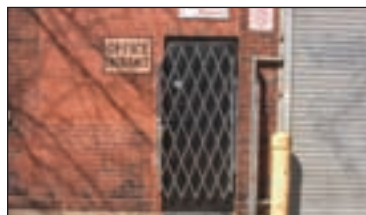
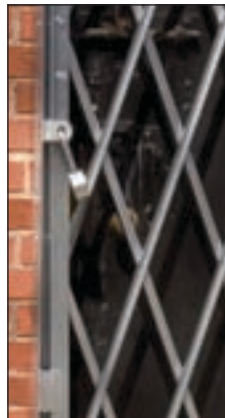

Model No.	Usable Width'	Collapsed Height'	Expanded Height'	Wt. lbs.	Price /Each
KH873	4	6.08	5.8	44	275.00
KH874	4	6.6	6.3	49	287.00
KH875	4	6.75	6.5	50	292.00

## STOREFRONT WINDOW GATES

- Retail store front security gates provides the highest quality loss prevention and security solutions
- Frame constructed from 1 1/2" x 1 1/2", 12-gauge angle iron, zinc-plated
- Channel constructed from 3/8" x 3/4", 14-gauge galvanized steel
- For added security, add an H bracket to each gate



Model No.	Height Collapsed'	Height Expanded'	Width'	Wt. lbs.	Price /Each
<b>SINGLE GATES</b>					
KH876	6.4	6	3	64	736.00
KH877	6.4	6	6	76	1214.00
KH878	6.4	6	9	98	1821.00
<b>DOUBLE GATES</b>					
KH879	6.4	6	10	124	1960.00
KH880	6.4	6	12	136	2183.00
KH881	6.4	6	16	172	2872.00
KH882	6.4	6	18	196	3340.00
<b>OPTIONS</b>					
KH883	H bracket for single gate	-	-	2.5	76.20
KH884	H bracket for double gate	-	-	2.5	152.00

CUSTOM SIZES AVAILABLE. CONTACT US TODAY!

## EXTRA HEAVY-DUTY FOLDING TRACK GATES

- Extra heavy-duty folding track gates provide access control and front-line security
- While locked they provide one of the strongest physical barrier to potential would-be intruders
- While closed or stacked, these gates slide discretely out of the way or completely hide-away within cabinets
- Main vertical channel is constructed from 1 7/8" x 1 3/8", 11-gauge galvanized steel
- Shear and intermediate vertical is constructed from 3/16" thick x 5/8" wide galvanized steel
- Installation hardware not included

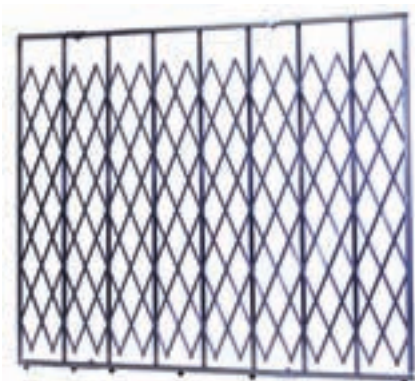

Model No.	Height'	Width'	Wt. lbs.	Price /Each
KH990	7.6	8	334	2466.00
KH991	7.6	10	418	3084.00
KH992	7.6	12	502	3951.00

## PORTABLE EXPANDING GATES

- Great for many applications: Blocking equipment, personnel and entrances
- Gates expand and lock to close off any opening
- When not in use, simply fold up, roll away and store
- Purchase optional add-on section to create larger barriers

Model No.	Collapsed		Expanded		Wt. lbs.	Price /Each
	Width"	Height"	Width"	Height"		
KA091	78	79.5	144	73.5	144	1454.00
KA126	Add-on section 6' long when expanded		72	-	-	840.00



CUSTOM SIZES AVAILABLE. CONTACT US TODAY!

## EXPANDABLE BARRIERS

- Steel and aluminum construction
- Collapsible design allows for easy storage when not in use
- Lightweight and free standing for easy setup when needed
- Side hook allows multiple units to be used together
- Expanded width: 10'
- Height: 37"
- Weight: 20 lbs.
- Colour: Black and yellow
- Optional caster kit: **SDK991**



Model No. **SDK990**  
Price/Each \$455.00

## PORTABLE INTERLOCKING BARRIERS

- Ideal for directing people in areas where crowd control is required
- Rugged welded steel construction
- Feet are removable so railing will lay flat for shipping and storage
- Includes connectors to attach multiple units together
- Overall size is 102" L x 40" H
- Distance between vertical bars: 7"
- Rail diameter: 1 5/8"
- Weight: 56 lbs.



Model No.	Description	Price /Each
SEE395	Galvanized Finish	172.00
SEE396	Safety Yellow Finish	195.00



# PORTABLE STRUCTURES & ENCLOSURES

## SELF-CLOSING SAFETY SWING GATES

- Suitable to use at any access point on a mezzanine or any fixed ladders
- Standard universal hinge assembly is versatile, fitting various railing types up to 2" O.D. or flat surface mounting
- Each gate has a 3 3/4" adjustment of gate width from nominal size
- Includes two stainless steel torsion spring self-closing mechanisms
- Economical, reliable, ships fully assembled and installs in minutes

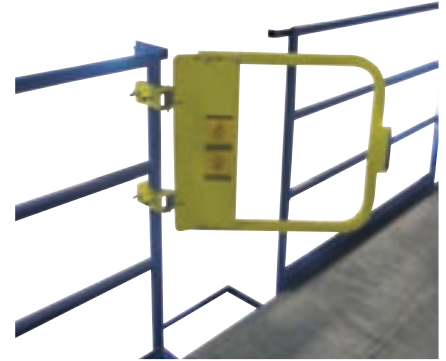

### POWDER COAT SAFETY YELLOW

Model No.	Dimensions of Opening"	Price /Each
ML349	16 3/4 - 20 1/2	435.00
ML350	19 3/4 - 23 1/2	441.00
ML351	22 3/4 - 26 1/2	440.00
ML352	25 3/4 - 29 1/2	446.00
ML353	28 3/4 - 32 1/2	452.00
ML354	31 3/4 - 35 1/2	457.00
ML355	34 3/4 - 38 1/2	462.00

### HOT-DIP GALVANIZED

Model No.	Dimensions of Opening"	Price /Each
ML376	16 3/4 - 20 1/2	435.00
ML377	19 3/4 - 23 1/2	441.00
ML378	22 3/4 - 26 1/2	446.00
ML379	25 3/4 - 29 1/2	450.00
ML380	28 3/4 - 32 1/2	456.00
ML381	31 3/4 - 35 1/2	461.00
ML382	34 3/4 - 38 1/2	468.00

Note: All models are available in stainless steel.

## INDUSTRIAL SAFETY GUARDRAILS

- Modular design of barrier guards allows you to design a system that meets specific equipment and property safeguarding needs
- 13-gauge steel rails offer enough strength to withstand a 10 000-lb load from breaking through at 4 mph when properly installed
- Posts are available in single and double height and are 5" x 5" with 10" x 10" base plates
- Single posts are 17" high and double are 44" high, rails are 12" high
- Powder coat safety yellow finish for durability and visibility
- All necessary installation hardware included except for anchors



### F.O.B. TERREBONNE, QC

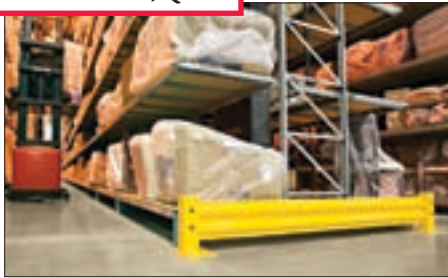

#### RAILS

Model No.	Guardrail Height"	Nominal Length"	Wt. lbs.	Price /Each
KH833	12	24	18	79.90
KH832	12	36	24	104.00
KH831	12	48	30	114.00
KH830	12	60	37	139.00
KH829	12	72	43	145.00
KH828	12	84	50	159.00
KH827	12	96	58	169.00
KH826	12	108	64	189.00
KH825	12	120	70	199.00

#### POSTS

Model No.	Description	Wt. lbs.	Price /Each
KH834	Modular Guardrail Post Single 17" Height	35	109.00
KH835	Modular Guardrail Post Double 44" Height	60	179.00

## PALLET RACK BACK GUARDS

Back guards help prevent accidents by keeping pallets and their contents from falling off the back of the rack. These guards increase safety where pedestrian pathways are behind the rack.

- Constructed using a 10-gauge frame, and 2" x 2", 10-gauge wire mesh with stiffeners
- Available in a variety of sizes to fit most pallet rack configurations
- Guard brackets are designed to fit almost any style of rack
- Durable safety yellow finish
- Hardware not included

KD131



ML231



Create a pallet rack back guard designed for your application

1. Choose one or a combination of back guard panels to create the required width and length

Model No.	Dimensions'	Weight lbs.	Price /Each
KH926	1 x 4	10	59.30
KH914	2 x 4	12	70.35
KH930	3 x 4	20	96.60
KD130	4 x 4	23	97.85
KD131	8 x 4	45	130.00

2. Choose a mounting bracket that provides the required depth
  - Minimum of four brackets required

Model No.	Dimensions"	Weight lbs.	Price /Each
ML231	4 x 6	2	11.60
ML232	4 x 9	2	13.85
ML233	4 x 12	3	13.85

3. Hardware required

For each additional panel, add: 2 x **MMB721** and 2 x **MMH254**  
 For each mounting bracket, add: 3 x **MMP624** and 3 x **MMB721**

## RACKING AISLE PROTECTORS

- Prevent collision damage to shelving/racking from fork lifts, pallet trucks or other in-plant vehicle accidents
- Corner wraps are 12" high with an angle of 5" H x 3" W x 1/4" D with holes for anchoring to the floor
- Protectors can be customized to any other lengths and/or depths required
- Floor anchors not included • Overall Width: 3"
- Overall Height: 12" • Colour: Safety Yellow
- Material: Steel • All welded construction

Model No.	Description	Overall Length"	Fits Racking Uprights	Price /Each
RN059	Single Wrap - Left	46-1/2	42" W	150.00
RN060	Single Wrap - Right	46-1/2	42" W	150.00
RN061	Single Wrap - Left	52-1/2	48" W	159.00
RN062	Single Wrap - Right	52-1/2	48" W	159.00
RN063	Double Wrap	50-1/4	42" W	230.00
RN064	Double Wrap	56-1/4	48" W	258.00

RN063



# PORTABLE STRUCTURES & ENCLOSURES

## PERIMETER GUARDS

- Create your own barrier guards with two styles to choose from: 2" x 2" welded wire mesh or 2" square tube
- Both feature a unique 49 1/2" overall height, and are easily installed
- Posts are constructed of 2" square tube with 5/16" base plate with holes for anchoring to floor
- Hardware to attach add-on sections is included
- Safety yellow or Kleton blue finish

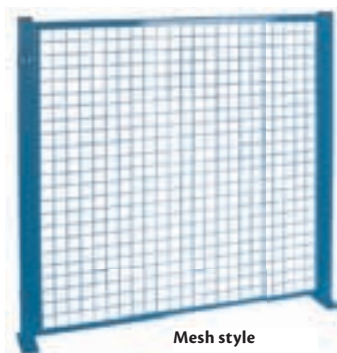

Mesh style

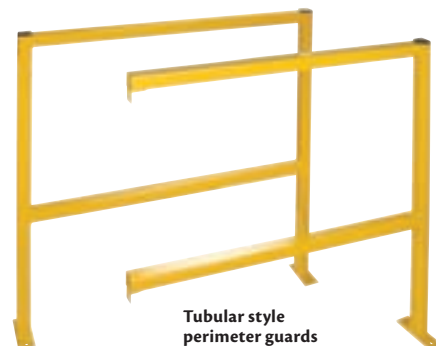

Tubular style perimeter guards

### MESH STYLE KITS

Description	Dimensions W" x H"	Wt. lbs.	Blue Model No.	Price /Each	Yellow Model No.	Price /Each
Starter Section	48 x 48	46	KH945	179.00	RL848	253.00
Add-On Section	48 x 48	34	KH946	135.00	RL849	200.00
Starter Section	96 x 48	65	KH947	218.00	RL850	301.00
Add-On Section	96 x 48	53	KH948	172.00	RL851	249.00

**Note:** Includes assembly fasteners, floor anchors and post caps

### MESH STYLE INDIVIDUAL COMPONENTS

Description	Dimensions W x H	Wt. lbs.	Blue Model No.	Price /Each	Yellow Model No.	Price /Each
Mesh Panel	4' x 4'	20	KD036	88.30	KD130	97.85
Mesh Panel	8' x 4'	39	KD037	125.00	KD131	130.00
Post Universal	49 1/2" H	13	KH861	41.85	KD129	43.70
Post Universal	99" H	22	KD053	56.50	KH860	59.25

### HARDWARE REQUIRED

Model No.	Description	Price /Each
KD001	Floor Anchors (Two per Post)	0.55
MMH262	5/16" x 3" Carriage Bolt (Four per Frame)	0.25
MMB721	5/16" Hex Nut (One Nut for Each MLK389)	0.04
KD116	Post Caps (One per Post)	1.37

## BOLLARDS

- Protect your warehouse equipment, as well as high traffic areas with these heavy-duty steel bollards
- 4" x 4" square tube welded to an 8" x 8" x 1/2" steel base, complete with four 3/4" diameter holes for anchoring to floor
- Safety yellow powder coated finish



Model No.	Height"	Wt. lbs.	Price /Each
KD125	24	30	139.00
KH857	36	40	179.00
KD126	48	50	199.00



## UPRIGHT PROTECTOR

- Protects industrial racking from damaging impacts that cause unsafe conditions
- Made from 1/4" thick steel
- 4 pre-drilled holes made for 1/2" anchors (not included)
- Safety yellow powder coated finish



Model No.	W"	O.A. Dimensions x D" x H"	Wt. lbs.	Price /Each
KH858	7	x 7 x 12	12	37.45
RB925	7	x 7 x 18 1/4	15	49.90



### TUBULAR STYLE

Model No.	Description	Dimensions W' x H"	Wt. lbs.	Price /Each
KD132	Starter Section	4 x 49 1/2	45	199.00
KD133	Add-On Section *	4 x 49 1/2	32	169.00
KD134	Starter Section	8 x 49 1/2	66	269.00
KD135	Add-On Section *	8 x 49 1/2	53	239.00

\*Hardware to attach add-on section is included

### HARDWARE REQUIRED

Model No.	Description	Price /Each
KD001	Floor Anchors (2 per post)	0.55
KD116	Post Caps (1 per post)	1.37

## SAFETY GUARDS

- Protect your equipment and personnel from accidental damage and injury with these low profile safety guards
- 4" x 4" square tube welded to an 8" x 8" x 1/2" base, complete with four 3/4" diameter holes for anchoring to floor
- Colour: Safety yellow powder coat finish

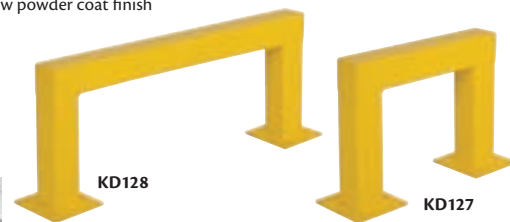

Model No.	Dimensions W" x H"	Wt. lbs.	Price /Each
KD127	24 x 18	65	269.00
KH855	36 x 18	75	325.00
KD128	48 x 18	85	329.00
KD136	24 x 42	95	359.00
KD856	36 x 42	110	426.00
KD139	48 x 42	115	408.00

## FLOOR ANGLE GUARD RAILS

- Floor angle guide rail helps keep traffic away from racking and shelving, walls, storage areas, offices, and other work areas
- The sturdy 5" H x 3" W x 1/4" D angle iron comes with holes to anchor to the floor
- Protectors can be customized to any other lengths and/or depths required
- Floor anchors not included
- Overall Width: 3"
- Overall Height: 5"
- Colour: Safety Yellow
- Material: Steel
- All welded construction



Model No.	Overall Length"	Wt. lbs.	Price /Each
RN065	48	26	70.40
RN066	60	33	82.60
RN067	120	66	164.00

# PORTABLE STRUCTURES & ENCLOSURES

## COLUMN PROTECTORS

- Protect your building's columns from damaging bumps by moving vehicles
- Octagon configuration for more rebounding ability
- 100% rust proof
- Flexible deflection design - capable of handling a hit from a 7000-lb forklift at 6 mph
- Easy to assemble
- Nylon fasteners (included) for breakaway ability make these extremely versatile
- Protect columns under virtually any condition and temperature down to 0°F
- Colour: Yellow
- Dimensions L x W x H: 22" x 22" x 40"
- Material: Linear low density polyethylene (LLDPE)
- Weight: 42 lbs.



Model No.	Inside Opening"	Opening Shape	Description	Price /Each
RN047	6 x 6	Square	Fits square or round columns up to 6" sq.	399.00
RN048	8 x 8	Square	Fits square or round columns from 6" sq. to 8" sq.	399.00
RN049	9 Dia.	Round	Fits round columns up to 9" sq.	399.00
RN050	10 x 10	Square	Fits square or round columns up to 10" sq.	399.00
RN051	8 x 10	Rectangular	Fits rectangular columns only 8" x 10"	399.00
RN052	12 x 12	Square	Fits square or round columns up to 12" sq.	399.00

## COLUMN PROTECTORS

- Affordable protection for warehouse and factory columns and beams
- Absorbs impact from tow motors, minimizing column, fork truck, and personnel damage and injury
- Blown-moulded (HDPE) protectors are resistant to most chemicals
- Feature key-lock to prevent slippage and assist with installation alignment
- Two halves attach with easy-to-install black straps (included)
- No tools required
- Colour: Yellow
- Material: High-density polyethylene (HDPE)



Model No.	Inside Opening"	Dimensions				Wt. lbs.	Price /Each
		L"	x	W"	x H"		
RN041	4-6	13	x	13	x 42	16	209.00
RN040	6 x 6	24	x	24	x 42	40	319.00
RN039	8 x 8	24	x	24	x 42	40	319.00
RN037	10 x 10	24	x	24	x 42	40	319.00
RN038	12 x 12	24	x	24	x 42	40	319.00

## CORNER PROTECTORS

- Corner Protectors help prevent damage to walls in areas with forklifts, hand trucks and other warehousing traffic
- These guard high-visibility yellow
- Made with high density polyethylene (HDPE)
- Crack and chipp resist
- Feature unique energy absorbing construction
- Anchors not included
- Can be mounted end to end
- Sold in sets of 2 protectors



Model No.	Dimensions					Wt. lbs.	Price /Set
	L"	x	W"	x	H"		
KH994	10	x	6	x	21	10	104.00
KH995	10	x	6	x	42	20	169.00

## WALL PROTECTORS

- Wall Protectors help prevent damage to walls in areas with forklifts, hand trucks and other warehousing traffic
- These guard high-visibility yellow
- Made with high density polyethylene (HDPE)
- Crack and chipp resist
- Feature unique energy absorbing construction
- Anchors not included
- Can be mounted end to end
- Sold in sets of 2 protectors



Model No.	Dimensions					Wt. lbs.	Price /Set
	L"	x	W"	x	H"		
KH996	42	x	2	x	6	8	129.00
KH997	42	x	2	x	10	14	139.00



## REMOVABLE ORNAMENTAL STEEL BOLLARDS

- Provides attractive yet functional barrier for vehicle access and parking
- Locks into galvanized steel socket cemented into ground (padlock not included)
- Cover plate on socket protects hole, leaving no protrusion above the surface after removal
- Dimensions: 4 1/2" dia. with 6" diameter rings
- Height: 40"
- Weight: 80 lbs.
- Finish: Powder black coating for durability

Model No. KH820  
Price/Each \$400.00



## POUR-IN-PLACE STEEL BOLLARDS

- Includes pass-through anchors on the bottom of bollard for securing into concrete
- Allows bollards to be installed permanently by setting them in concrete
- Removable black rubber top cap allows for concrete to be poured into the bollard for increased strength
- Heavy-duty welded construction for durability
- Finish: Safety yellow powder coating for visibility



Model No.	Usable Height"	Overall Height"	Outside Diameter"	Wt. lbs.	Price /Each
KH814	25	35.5	5-9/16	44	163.00
KH815	36.5	46.5	5-9/16	59	215.00
KH816	42.5	52.5	5-9/16	73	269.00
KH817	48.5	58.5	5-9/16	88	319.00

## SOFT EDGE FLEXIBLE WARNING & PROTECTION SYSTEMS

- Tough, flexible polyurethane foam extrusions reduce the risk of personnel injury at high risk corners
- When applied to machinery, furnishings and walls, Soft Edge prevents impact damages by absorbing even the hardest of impacts
- Highly visible black and yellow markings offer permanent warning in dangerous areas
- Simple "peel-away" adhesive installation on grease-free surfaces
- Excellent temperature range from -40°C to 100°C

**Knuffi**

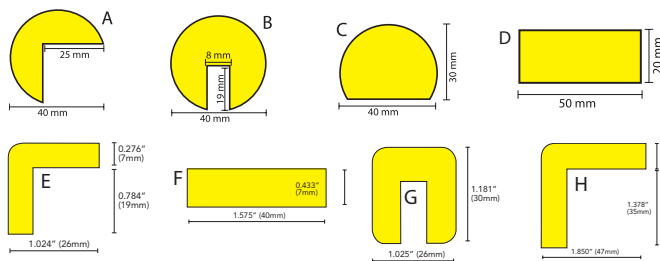

Style	1 Metre Model No.	Price /Each	5 Metres Model No.	Price /Each
A	KH866	41.10	KH865	180.00
B*	KH868	39.30	KH867	178.00
C	KH870	40.40	KH869	181.00
D	KH872	49.40	KH871	244.00
E	KH952	39.10	KH953	192.00
F	KH954	38.00	KH955	190.00
G*	KH956	50.30	KH957	251.00
H	KH958	51.50	KH959	257.00

\* Does not have peel-away adhesive. Held by pressure fit.

## POLYETHYLENE BOLLARD COVERS

- Enhance and protect the appearance of your steel bollards
- Reduce maintenance; avoid scraping and painting each spring
- Constructed of 1/8" UV stable polyethylene for durability
- Easy installation with patented RipperTabs™ included
- Colour: Safety yellow with reflective red tape or high visibility red with white reflective tape, for great visibility day or night
- 5-year warranty against fading and cracking



Yellow Model No.	Red Model No.	Fits Bollard Diameter"	Fits Bollard Length"	Wt. lbs.	Price /Each
KH806	KH836	4.5	52	7	72.80
KH808	KH838	4.5	64	9	80.90
KH809	KH839	6.6	52	8	89.10
KH810	KH840	6.6	60	9	92.90
KH811	KH841	6.6	72	10	101.00

## CORNER ACCESSORIES

Makes a neat corner where two foam bumper guards protection profiles meet.



MN379



MN380



MN381



MN382

**Knuffi**

Model No.	Description	Price /Each
MN379	2 Way - Use with Profile A	33.00
MN380	3 Way - Use with Profile A	35.10
MN381	2 Way - Use with Profile E	30.20
MN382	3 Way - Use with Profile E	32.70
MN383	2 Way - Use with Profile H	36.10
MN384	3 Way - Use with Profile H	38.20

# PORTABLE STRUCTURES & ENCLOSURES

Rugged Kleton wire mesh partitions and enclosures provide maximum security at a minimal cost. It is ideal for the storage of tools, valuable inventory, hazardous materials and any area of your plant where restricted access is required.

Wire mesh panels permit full visibility and allow for unrestricted circulation of air, heat and light, providing an ideal storage facility.

- 2" x 2" x 10-gauge wire mesh
- 10-gauge frame (stiffeners included on all applicable sizes)
- Pre-drilled modular components allow for quick and easy installation
- Durable Kleton blue or safety yellow finish (Other colours available)



## WIRE MESH PARTITION COMPONENTS

Everything necessary to create your own custom enclosure. Fast and easy assembly, multiple sizes available. Please follow these guidelines for determining the components required.

### 1. UNIVERSAL POSTS

A post must be placed at each end of every panel (or of every stack of panels). Be sure to calculate an extra 2" of overall wall length for each post added. When a post meets an existing wall, add one **KD115** wall bracket for proper support (fasteners are included with **KD115** to mount to post, not to wall).

Universal Posts

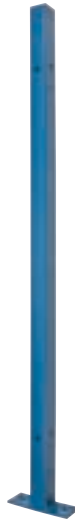

Blue Model No.	Yellow Model No.	Height	Wt. lbs.	Price /Each
KD053	KH860	8' 3"	22	56.50
KD046	KH922	10' 3"	27	84.70
KD050	KH923	12' 3"	32	99.90

### 2. PANELS

Whenever possible, stacking panels horizontally (one above the other) is more economical than placing them vertically (next to each other) - this is because fewer posts are required for wall support when panels are stacked.

**Examples:**

- For an 8' high partition, stack two **KD037** (8' x 4') panels horizontally
- For a 10' high partition, stack two **KD037** (8' x 4') and one **KD033** (8' x 2') panel horizontally
- For a 12' high partition, stack three **KD037** (8' x 4') panels horizontally

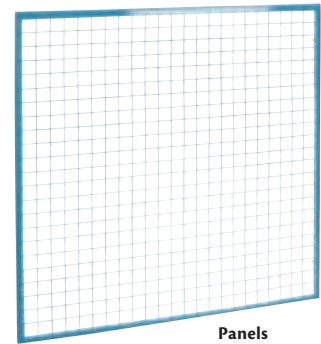

Panels

Blue Model No.	Yellow Model No.	Frame Dimensions			Wt. lbs.	Price /Each
		W'	x	H'		
KD121	KH926	4	x	1	10	59.90
KD120	KH927	8	x	1	21	79.90
KD030	KH928	2	x	2	10	73.90
KD031	KH929	3	x	2	11	76.90
KD032	KH914	4	x	2	12	69.90
KD033	KH915	8	x	2	31	99.90
KD034	KH916	8	x	3	40	119.00
KD035	KH930	3	x	4	20	99.90
KD036	KD130	4	x	4	23	88.50
KD037	KD131	8	x	4	45	125.00

### 3. ADJUSTABLE FILLER PANELS

Adjustable filler panels fill in blank spots on the ends of wire mesh partitions to plug up potential security risks. Filler panels come in two sizes: 1' x 4' and 1' x 8' that slide over the ends of existing wire mesh sections. Bolt holes on the filler panels are separated per every inch and allow the filler panel to fill in a space between 6" and 10" wide. The holes line up with holes on the existing panel which are drilled in at the top and bottom to securely fasten the filler panel in two places.

Adjustable Filler Panels



Blue Model No.	Yellow Model No.	Dimensions			Wt. lbs.	Price /Each
		W'	x	H'		
KD119	KH924	4	x	1	5	51.90
KD118	KH925	8	x	1	10	79.90



Safety Yellow

## WIRE MESH PARTITION COMPONENTS (CONTINUED)

Everything necessary to create your own custom enclosure. Fast and easy assembly, multiple sizes available. Please follow these guidelines for determining the components required.



CUSTOMIZE IT TO YOUR SPECIFICATIONS.

### 4. SWING DOORS

#### HEAVY-DUTY

- Frame constructed with 1 1/4" x 1 1/4" square tube and 1" x 1" angle iron
- All are 7' in height and include a 1' transom for a total of 8' height
- May swing outwards to the left or to the right (except the **KD112** and **KH937** heavy swing door with wicket which swings open to the left only)
- Fasteners are included

#### STANDARD-DUTY

- Frame constructed with 1 1/4" x 1 1/4" angle iron frame
- All are 7' in height and include a 1' transom for a total of 8' height
- May swing outwards to the left or to the right
- Fasteners are included

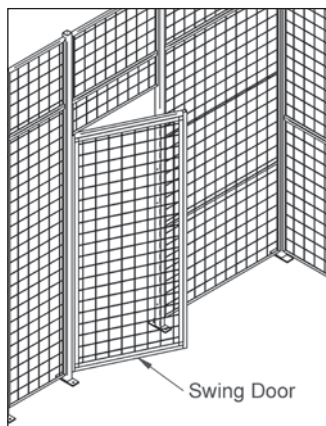

### 5. SLIDING DOORS

#### HEAVY-DUTY

- Frame constructed with 1 1/4" x 1 1/4" square tube and 1" x 1" angle iron
- All are 7' 7" in height and require one or more 8' lengths of 5" tall sliding door track, for a total of 8' height
- All sliding doors may slide open to the left or to the right
- To properly mount a sliding door, a post must be located on the side onto which the door slides, at the same distance away from the opening as the doors width

#### STANDARD-DUTY

- Frame constructed with 1 1/2" x 1 1/2" angle iron frame
- All are 7' 7" in height and require one or more 8' lengths of 5" tall sliding door track, for a total of 8' height
- All sliding doors may slide open to the left or to the right
- To properly mount a sliding door, a post must be located on the side onto which the door slides, at the same distance away from the opening as the doors width

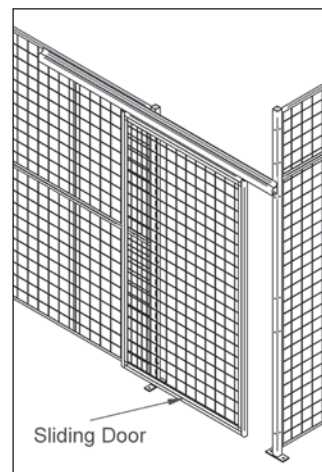

Blue Model No.	Yellow Model No.	Description	Dimensions W' x H'	Wt. lbs.	Price /Each
<b>KD110</b>	<b>KH933</b>	Heavy-Duty Swing Door	3 x 7	65	<b>378.00</b>
<b>KH853</b>	<b>KH934</b>	Standard-Duty Swing Door	3 x 7	54	<b>339.00</b>
<b>KD111</b>	<b>KH935</b>	Heavy-Duty Swing Door	4 x 7	74	<b>395.00</b>
<b>KH854</b>	<b>KH936</b>	Standard-Duty Swing Door	4 x 7	62	<b>345.00</b>
<b>KD112</b>	<b>KH937</b>	Heavy-Duty Swing Door w/Wicket	4 x 7	85	<b>949.00</b>

Blue Model No.	Yellow Model No.	Description	Dimensions W' x H'	Wt. lbs.	Price /Each
<b>KH852</b>	<b>KH938</b>	Standard-Duty Sliding Door	4 x 8	71	<b>209.00</b>
<b>KD106</b>	<b>KH939</b>	Heavy-Duty Sliding Door	4 x 8	85	<b>239.00</b>
<b>KD108</b>	<b>KH940</b>	Heavy-Duty Sliding Door	8 x 8	122	<b>539.00</b>
<b>KD107</b>	<b>KH941</b>	Heavy-Duty Sliding Door	8 x 10	148	<b>949.00</b>

### 6. HARDWARE REQUIRED

#### For Each Stacked Panel Add:

- 4 x **MMH254**, 4 x **MMB721** for each 8' stacked panel
- 2 x **MMH254**, 2 x **MMB721** for each stacked panel under 8' long

#### For Each Post Add:

- 8 x **MMH262**, 8 x **MMB721**, 2 x **KD001** for each **KD053** and **KH860**
- 12 x **MMH262**, 12 x **MMB721**, 2 x **KD001** for each **KD046** and **KH922**
- 12 x **MMH262**, 12 x **MMB721**, 2 x **KD001** for each **KD050** and **KH923**

#### For Each Sliding Door Add:

- 1 x **KD028**, 1 x **KD029** door track for each **KD106** and **KH852** 4' wide sliding door
- 1 x **KD028**, 2 x **KD029** door track for each **KD108** and **KD107** 8' wide sliding door

Blue Model No.	Yellow Model No.	Description	Wt. lbs.	Price /Each
<b>KD029</b>	<b>KH942</b>	8' Door Track	16	<b>159.00</b>
<b>KD028</b>	<b>KH943</b>	Sliding Door Hardware Kit	6	<b>169.00</b>
<b>KD115</b>	<b>KH944</b>	Wall Bracket Kit	0.1	<b>11.90</b>
<b>MMH254*</b>	-	5/16" x 1" Carriage Bolt	0.01	<b>0.15</b>
<b>MMH262*</b>	-	5/16" x 3" Carriage Bolt	0.01	<b>0.25</b>
<b>MMM966</b>	-	Nut 5/16" Hex	0.01	<b>0.15</b>
<b>KD001</b>	-	3/8" Anchor Bolt	0.01	<b>0.55</b>

\* 1 x **MMB721** is required for each **MMH254** and **MMH262**.



# PORTABLE STRUCTURES & ENCLOSURES

## WIRE MESH PARTITION KITS

Rugged Kleton wire mesh partitions and enclosures provide maximum security at low cost for tools, valuable inventory, hazardous materials, and any area of your plant where restricted access is required. Bolt-down posts and reinforced panels provide the strength that your application demands. Standard **STOCK SIZES** include all basic bolt-together hardware required for fast and easy installation of modular wall and roof panels, and a standard 4' x 8' or 8' x 8' sliding door which may be located on any side, opening left-to-right or right-to-left. This system provides the versatility needed to expand or modify your enclosure quickly and at minimum cost. Order an enclosure with a roof for maximum security. **CUSTOM SIZES** can be designed to suit your special application regardless of the size required.

Colour: Kleton blue.



TYPE A - 2 SIDES

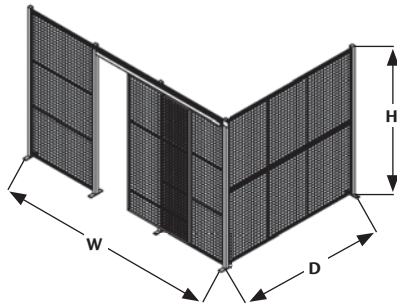
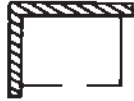

Unit Height	Overall Wall Size		Standard Sliding Door Size		Without Roof			With Roof		
	W	x D	W'	x H'	Model No.	Wt. lbs.	Price /Each	Model No.	Wt. lbs.	Price /Each
8'3"	12'8"	x 8'4"	4	x 8	<b>KD069</b>	417	<b>1172.00</b>	<b>KD070</b>	670	<b>1998.00</b>
8'3"	16'8"	x 12'6"	4	x 8	<b>KD057</b>	535	<b>1469.00</b>	<b>KD058</b>	1009	<b>2885.00</b>
8'3"	24'8"	x 16'6"	8	x 8	<b>KD061</b>	682	<b>2073.00</b>	<b>KD062</b>	1485	<b>4486.00</b>
12'3"	12'8"	x 8'4"	4	x 8	<b>KD067</b>	583	<b>1730.00</b>	<b>KD068</b>	836	<b>2556.00</b>
12'3"	16'8"	x 12'6"	4	x 8	<b>KD055</b>	758	<b>2183.00</b>	<b>KD056</b>	1232	<b>3599.00</b>
12'3"	24'8"	x 16'6"	8	x 8	<b>KD059</b>	977	<b>2895.00</b>	<b>KD060</b>	1780	<b>5307.00</b>

TYPE B - 3 SIDES

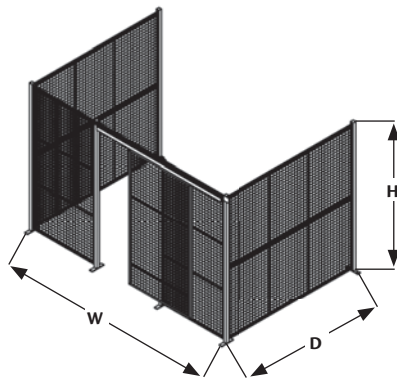

Unit Height	Overall Wall Size		Standard Sliding Door Size		Without Roof			With Roof		
	W	x D	W'	x H'	Model No.	Wt. lbs.	Price /Each	Model No.	Wt. lbs.	Price /Each
8'3"	12'8"	x 8'4"	4	x 8	<b>KD085</b>	511	<b>1471.00</b>	<b>KD086</b>	758	<b>2292.00</b>
8'3"	16'8"	x 12'6"	4	x 8	<b>KD073</b>	690	<b>1943.00</b>	<b>KD074</b>	1158	<b>3339.00</b>
8'3"	24'8"	x 16'6"	8	x 8	<b>KD077</b>	878	<b>2667.00</b>	<b>KD078</b>	1677	<b>5030.00</b>
12'3"	12'8"	x 8'4"	4	x 8	<b>KD083</b>	730	<b>2185.00</b>	<b>KD084</b>	977	<b>3007.00</b>
12'3"	16'8"	x 12'6"	4	x 8	<b>KD071</b>	997	<b>2937.00</b>	<b>KD072</b>	1465	<b>4333.00</b>
12'3"	24'8"	x 16'6"	8	x 8	<b>KD075</b>	1273	<b>3804.00</b>	<b>KD076</b>	2072	<b>6166.00</b>

TYPE C - 4 SIDES

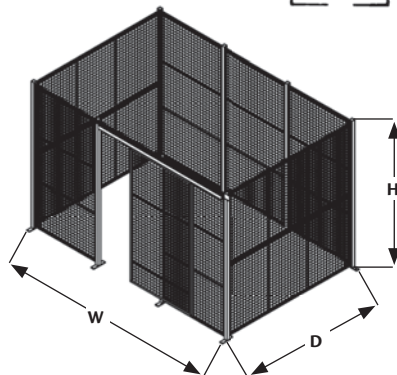

Unit Height	Overall Wall Size		Standard Sliding Door Size		Without Roof			With Roof		
	W	x D	W'	x H'	Model No.	Wt. lbs.	Price /Each	Model No.	Wt. lbs.	Price /Each
8'3"	12'8"	x 8'4"	4	x 8	<b>KD101</b>	688	<b>1931.00</b>	<b>KD102</b>	923	<b>2729.00</b>
8'3"	16'8"	x 12'6"	4	x 8	<b>KD089</b>	912	<b>2525.00</b>	<b>KD090</b>	1368	<b>3862.00</b>
8'3"	24'8"	x 16'6"	8	x 8	<b>KD093</b>	1190	<b>3489.00</b>	<b>KD094</b>	1975	<b>5787.00</b>
12'3"	12'8"	x 8'4"	4	x 8	<b>KD099</b>	996	<b>2974.00</b>	<b>KD100</b>	1231	<b>3771.00</b>
12'3"	16'8"	x 12'6"	4	x 8	<b>KD087</b>	1330	<b>3881.00</b>	<b>KD088</b>	1786	<b>5219.00</b>
12'3"	24'8"	x 16'6"	8	x 8	<b>KD091</b>	1740	<b>5060.00</b>	<b>KD092</b>	2525	<b>7357.00</b>

# PORTABLE STRUCTURES & ENCLOSURES

- Curtain partitions screen, isolate, enclose and protect any area of any size
- Commonly used in welding and paint shops, but can be used anywhere
- Brackets made of 16-gauge steel and designed for wall or ceiling mount but can be self supported by floor stands
- Large selection of drape material can be utilized with any curtain

## DESIGN YOUR OWN CURTAIN

**Curtains** - Take exact length of area of enclosure and add 10% fullness for proper draping. Then multiply length and height to obtain square footage. Curtains hemmed on top and two sides 2" pocket on bottom side. Brass grommets spaced every 12". Refer to model number for square footage cost of fabric required.

**Track** - Straight and curved. Straight track available in 5' and 10' lengths. Curved corners are 3' long with 2' radius welded splicer on each end included. When using a curved track, length is increased by 2', e.g. 8' straight track with a curve at each end overall = 12'.

**Carriers** - Since curtains are made to any length be sure to add one additional carrier to actual length of curtain ordered. For example every 10' of curtain is fabricated with 11 grommets on top side. Therefore 11 carriers are required. A double carrier should be used at the beginning of each curtain. Steel roller carriers are permanently lubricated enclosed bearings.

**Clamps** - Available for flush ceiling/beam mounting and floor mounting. Clamps can also be used as track splicers. All fasten with supplied Allen bolts. Order sufficient clamps to support track every 5'. When free standing uprights are required, be sure to specify clamps for fastening track on posts **KB032** (Posts are required every 8'). Other custom heights on application.

**Note:** All posts should be lagged or welded to floor as required.

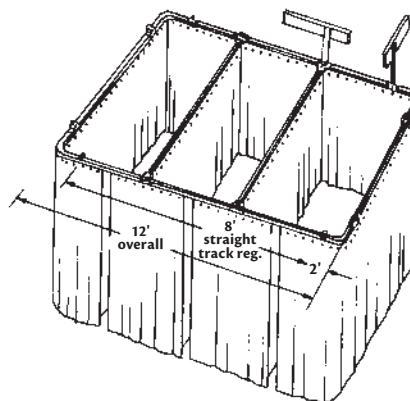

## TRACKS

Model No.	Description	Price /Each
KB017	5', 16 ga. Track	29.60
KB016	10', 16 ga. Track	59.10
KB029	Track Splicer	8.13
KB012	End Stop	2.41

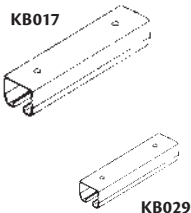

## ROLLERS

KB013	Single Nylon Roller 25 lbs., Cap. 2 1/2" Hook	4.13
KB018	Single Steel Roller 75 lbs., Cap. 2 1/2" Hook	11.40
KB019	Double Steel Roller 125 lbs., Cap. 2 1/2" Hook	40.90
KB014	Overlap By-Pass Roller 12" Long x 2 3/4" High	52.90

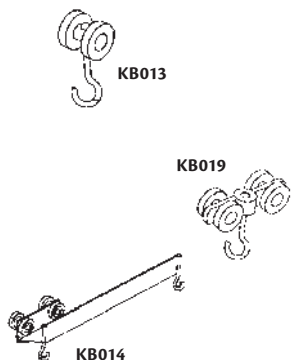

## WALL MOUNTS

KB020	Wall Connector Bracket, Down	11.50
KB021	Wall Connector Bracket, Up	11.50
KB011	End Connector Fastener, Up	10.90
KB010	End Connector Fastener, Down	10.90

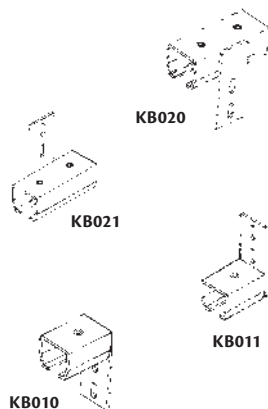

## CURTAINS

Model No.	Description	Price /Each
KB040	10 oz./sq.yd., Before Treatment Cotton Duck, Flame Resistant Army Green	3.54/sq.ft.
KB004	14 mil Yellow PVC, Flame Resistant	2.80/sq.ft.
KB003	14 mil Green PVC, Flame Resistant	2.80/sq.ft.
KB038	20 mil Clear PVC, Flame Resistant	3.60/sq.ft.

**Note:** Other colours are available.

## FLOOR MOUNTS

Model No.	Description	Price /Each
KB009	3' 90° Curve Track	159.00
KB025	Track Splicer	55.20
KB027	90° Corner Connector	60.90
KB024	3-Way T-Connector	73.00
KB032	8' Square Post	76.00
KB005	12" x 12" Base	79.30

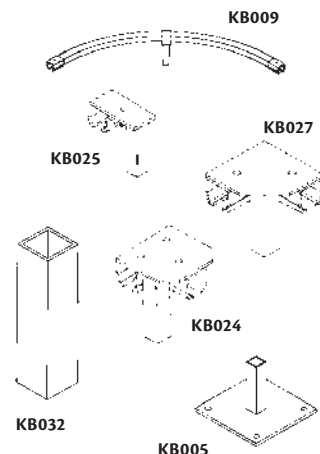

## BEAM MOUNTS/SUSPENSION

KB008	3' 90° Curve Track	128.00
KB031	Ceiling Clamp	12.70
KB028	90° Corner Connector	43.80
KB023	3-Way T-Connector	55.20

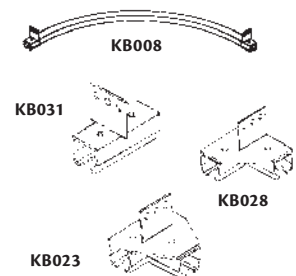

## CEILING MOUNTS

KB007	3' 90° Curve Track, 3 flush connectors	129.00
KB030	Track Splicer	15.60
KB026	90° Corner Connector	39.20
KB022	3-Way T-Connector	52.90

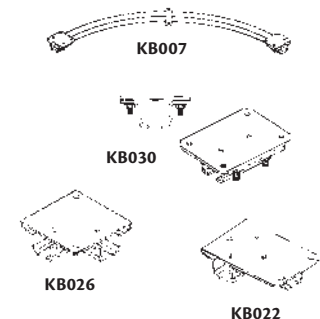

# PORTABLE STRUCTURES & ENCLOSURES

## STRIP CURTAIN DOORS

Everything you need in one package to install your own strip curtain door and save money!

### ORDERING INFORMATION

Every strip curtain door comes complete with PVC strips and universal hardware for mounting strip curtain. Simple to follow installation instructions are included in every package.

- Determine inside width and height of door opening.
  - Note:** If mounting on door above lintel, measure from floor to mounting height.
- Select type of PVC material required: STANDARD or LOW TEMP.
  - Standard** recommended for temperatures from -23°C to 66°C.
  - Low Temp.** recommended for interior use only for temperatures from -40°C to 66°C.
- Select from the standard sizes listed in the chart below.
  - Note:** If required size is not available, order the next largest size. Installation instructions describe how simple trimming can custom fit almost any door opening.
- Special size doors and hanging applications are available upon request.
- For overhead doors, please call one of our sales representatives for assistance.



### INTERIOR DOORS



- Save energy costs**
- The optimal solution to open door heat/cooling loss
- Reduce noise pollution**
- Provides the ideal acoustical barrier around noisy equipment

### CONVEYORS

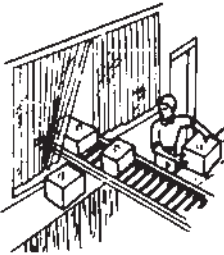

- Provide extra safe passage**
- People can see and be seen so there's less chance of accidents
- Control smoke, dust and sprays**
- Strip curtains can control in-plant contaminants to improve employee environment

### DOCKS



- Low maintenance**
- Clear flexible vinyl resists stretching and stands up to abrasion
  - All aluminum hardware is used for maximum durability
  - May be quickly and easily cleaned with detergents or cleansing agents that are free from abrasives
  - Deep stains and ingrained dirt can be removed by carefully applying ethanol



Customize it to your specifications.

Every strip curtain door comes complete with PVC strips and universal hardware for door or wall mounting. Simple to follow installation instructions included in every package.

### EASY TO ORDER

It's easy to order the strip curtain that fits your door exactly because seven standard sizes can be made to fit 95% of most door openings.

Special sizes are available.

### IN-STOCK DELIVERY

We have the strip curtain package you need, in-stock, ready to be delivered to your door.

### STANDARD DOOR SIZES

Strip Size	Door Opening W' x H'	Wt. lbs.	Model No. Standard	Price /Each	Model No. Low Temp.	Price /Each
8" (8" x 0.080)	4 x 7	25	KF022	169.00	KF004	176.00
	5 x 8	35	KF023	244.00	KF005	282.00
	6 x 8	40	KF024	290.00	KF006	313.00
12" (12" x 0.120)	8 x 8	80	KF026	546.00	KF008	616.00
	8 x 10	100	KF025	642.00	KF007	740.00
	10 x 10	125	KF020	809.00	KF002	910.00
	12 x 12	175	KF021	1126.00	KF003	1238.00

**Note:** Doors with 8" strips have 2" standard overlap. Doors with 12" strips have 4" standard overlap.

### REPLACEMENT STRIPS - 5 PER CARTON

Strip Size	Wt. lbs.	Model No. Standard	Price /Each	Model No. Low Temp.	Price /Each
8" x 0.080 x 8'	15	KF032	92.80	KF013	109.00
12" x 0.120 x 12'	45	KF029	290.00	KF011	331.00

### BULK ROLLS

Strip Size	Colour	Roll'	Wt. lbs.	Model No. Standard	Price /Each	Model No. Low Temp.	Price /Each
8" x 0.080	Clear	300	99	KF033	524.00	KF014	583.00
12" x 0.120	Clear	200	150	KF030	766.00	KF012	909.00
8" x 0.080	Dark Amber	300	99	ML959*	857.00	-	-

\* For welding applications.

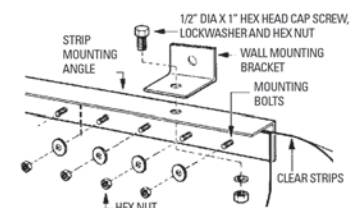

### FIXED MOUNTING SYSTEM

Model No.	Description	Price/Each
KF001	Complete 4' aluminum angle mount	46.90



## CUSTOM STRIP DOORS

In some applications strip curtain door kits can not be used. However, custom doors can be designed to fit your application. Generally strip curtain material is available in 8" and 12" standard and low temperature versions. Commonly used mounting hardware includes universal mount aluminum angle, straight roller track and hinged roller track. For special applications the "ordering information" provided will help you determine the type of system you will require. Our customer service representatives are also available, should you require any assistance. Please call for special pricing whenever square footage is required.

### ORDERING INFORMATION

- 1) Determine the type of mounting system required: angle mount or sliding door. Other custom doors can be designed.
- 2) Choose overlapping requirement based on the location and type of traffic involved.
- 3) Measure door opening giving proper allowances for the type of mounting system.
- 4) Calculate approximate amount of square feet required.

### OVERLAPPING METHODS

Overlapping with Kleton custom doors offers three basic overlap methods. With holes on 1" centres, almost any overlap is possible. Our standard doors under 6' x 8' use 1/2 overlap. Doors over 8' x 8' use 2/3 overlap.

1/2, 2/3 overlap are the most common and are recommended for moderate temperature differential and personnel equipment passage. Full overlap is recommended for large temperature differentials and light winds, also ideal for noise control and doors in excess of 12' high.

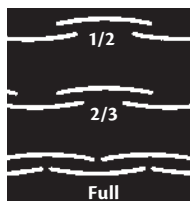

### FIXED MOUNTING SYSTEM

Universal aluminum angle mount can be used for both wall or lintel mount applications. Measure door opening, for wall mount add 6", lintel mounts use exact dimension. Angle comes in 4' sections, please indicate if a solid one length angle is required. All hardware included.

**Model No. KF001** Aluminum Angle Per 4 ft. Complete  
**Price/Each \$46.90**

### SLIDING STEEL DOOR MOUNT

Strips are attached to a trolley assembly. The mechanism enables removal of strip material from door opening. Allowing unobstructed traffic movement. The "curtain-like" structure can be parted on either side or in the middle. Allow sufficient wall space on either side of door as needed. Track available in 5' or 10' lengths, cut lengths available. Trolley assembly available in 2' and 3' length with steel wheels, all trolleys interconnect. Also available in hinged roller track for curved door systems.

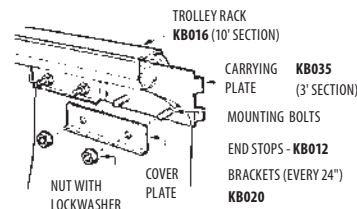

Model No.	Description	Price /Each
KB016	Roller Track 10'	59.10
KB017	Roller Track 5'	29.60
KB034	Roller Assembly 2' Steel Rollers	49.40
KB035	Roller Assembly 3' Steel Rollers	62.10

Model No.	Description	Price /Each
KB033	Hinged Trolley 1' Section	36.90
KB012	Track End Stop	2.41
KB020	Track Mounting Bracket/Coupler	11.50
KB036	4' Pull Rope	24.20

Note: Special sizes available.



**Kleton builds quality and dependability into all of their products!**

Look throughout the catalogue for the Kleton Custom Symbol indicating which products can be custom built to meet your specifications.

## BUILT KLETON TOUGH



### CUSTOMIZE . . .

- Strip Curtain Doors
- Platform Trucks
- Safety Guards
- Bollards
- Gas Cylinder Cabinets
- Workbenches
- Shelf Trucks
- And more...

**Call us with your specs today!**

**KLETON**



# STORAGE CABINETS

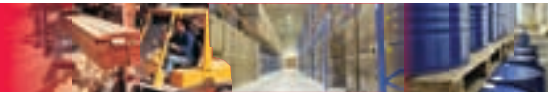

making workspace work®

## DRAWER CABINETS

### LOCKABLE CABINETS

- Safety, security, reduced shrinkage
- All cabinets come with individual lock and two keys
- Lock cores can be exchanged in the field for both keyed alike and master key systems

### ERGONOMIC HANDLES

- Improved safety, appearance and ergonomics
- When drawers are closed, handles are flush with housing so nothing protrudes
- Drawer handles are full width, and are located at top of drawer

### HINGED LABEL HOLDERS

- Easy labeling of drawer contents
- Drawer handles are covered with clear hinged covers for display of drawer labels

### 100% FULL EXTENSION DRAWERS

- Easy access and full use of the furthest corners of storage
- Continuous smooth extension even with a full load with a 400-lb. capacity

### INSTALLED DRAWER DIVIDERS

- Fast, accurate identification of compartment contents and easier inventory control
- Angled tops allow easy identification of contents and can accommodate most bar code labels

### PREVENTIP® INTERLOCK SYSTEM

- Added safety and security
- Unique, patented drawer locking system ensures that when one drawer is extended, all other drawers are locked closed to prevent accidental tip-over

### EXCLUSIVE SUSPENSION SYSTEM

- Durable, smooth, quiet operation
- Lista's suspension system has been tested against the globally respected RAL-RG 614 standard
- The drawers exceeded the required number of cycles at full load without diminished performance



### FORK TRUCK BASE WITH FRONT AND REAR COVERS

- Transport your cabinet easily from one location to another

Overall Dimensions: 28 1/4" W x 28 1/2" D x 41 3/4" H  
 Number of drawers: 5  
 Number of compartments: 61  
**Model No. F1125** Bright blue  
**Model No. F1126** Light grey  
**Price/Each \$2326.00**

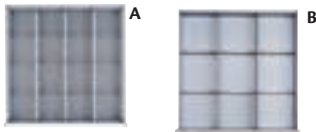

### DIVIDERS

- A - Drawer 1-3
- B - Drawer 4
- C - Drawer 5



Overall Dimensions: 28 1/4" W x 28 1/2" D x 41 3/4" H  
 Number of drawers: 7  
 Number of compartments: 114  
**Model No. F1127** Bright blue  
**Model No. F1128** Light grey  
**Price/Each \$2762.00**

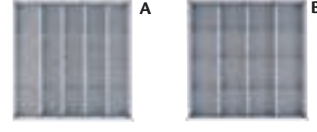

### DIVIDERS

- A - Drawer 1-4
- B - Drawer 5
- C - Drawer 6-7



Overall Dimensions: 28 1/4" W x 28 1/2" D x 41 3/4" H  
 Number of drawers: 9  
 Number of compartments: 154  
**Model No. F1129** Bright blue  
**Model No. F1130** Light grey  
**Price/Each \$3126.00**

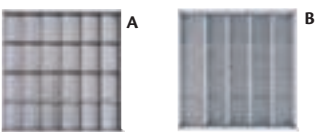

### DIVIDERS

- A - Drawer 1-2
- B - Drawer 3-4
- C - Drawer 5-7
- D - Drawer 8-9



Overall Dimensions: 28 1/4" W x 28 1/2" D x 41 3/4" H  
 Number of drawers: 10  
 Number of compartments: 210  
**Model No. F1131** Bright blue  
**Model No. F1132** Light grey  
**Price/Each \$3438.00**

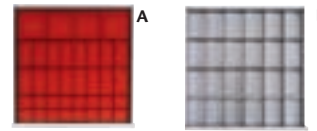

### DIVIDERS

- A - Drawer 1-2 (with red plastic inserts)
- B - Drawer 3-4
- C - Drawer 5-6
- D - Drawer 7-8
- E - Drawer 9-10



Note: Other colours available upon request

## DRAWER CABINETS

Overall Dimensions: 40 1/4" W x 22 1/2" D x 41 3/4" H  
 Number of drawers: 5  
 Number of compartments: 57  
**Model No. FI133** Bright blue  
**Model No. FI134** Light grey  
**Price/Each \$2485.00**

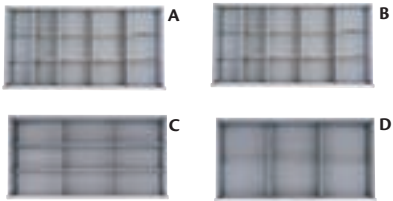

**DIVIDERS**  
 A - Drawer 1-2  
 B - Drawer 3  
 C - Drawer 4  
 D - Drawer 5

Overall Dimensions: 40 1/4" W x 22 1/2" D x 41 3/4" H  
 Number of drawers: 7  
 Number of compartments: 96  
**Model No. FI135** Bright blue  
**Model No. FI136** Light grey  
**Price/Each \$2857.00**

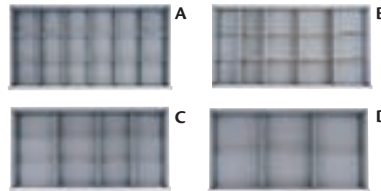

**DIVIDERS**  
 A - Drawer 1-2  
 B - Drawer 3-4  
 C - Drawer 5-6  
 D - Drawer 7

Overall Dimensions: 40 1/4" W x 22 1/2" D x 41 3/4" H  
 Number of drawers: 9  
 Number of compartments: 117  
**Model No. FI137** Bright blue  
**Model No. FI138** Light grey  
**Price/Each \$3172.00**

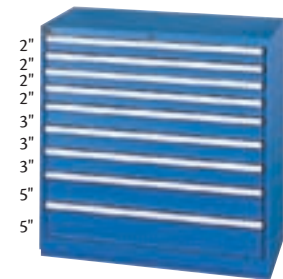
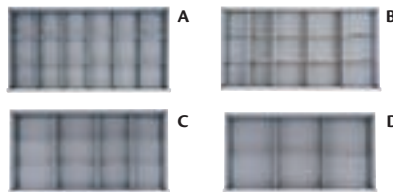

**DIVIDERS**  
 A - Drawer 1-2  
 B - Drawer 3-5  
 C - Drawer 6-7  
 D - Drawer 8-9

Overall Dimensions: 28 1/4" W x 28 1/2" D x 59 1/2" H  
 Number of drawers: 8  
 Number of compartments: 88  
**Model No. FI139** Bright blue  
**Model No. FI140** Light grey  
**Price/Each \$3331.00**

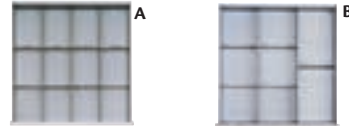

**DIVIDERS**  
 A - Drawer 1-6  
 B - Drawer 7-8

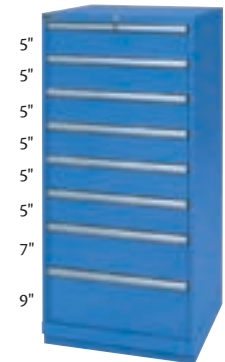

Overall Dimensions: 28 1/4" W x 28 1/2" D x 59 1/2" H  
 Number of drawers: 9  
 Number of compartments: 124  
**Model No. FI141** Bright blue  
**Model No. FI142** Light grey  
**Price/Each \$3569.00**

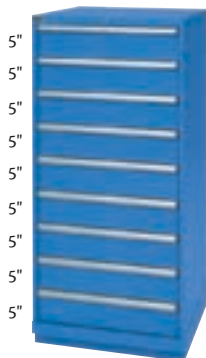
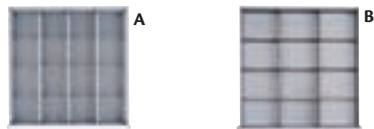

**DIVIDERS**  
 A - Drawer 1-4  
 B - Drawer 5-9

Overall Dimensions: 28 1/4" W x 28 1/2" D x 59 1/2" H  
 Number of drawers: 11  
 Number of compartments: 172  
**Model No. FI143** Bright blue  
**Model No. FI144** Light grey  
**Price/Each \$3881.00**

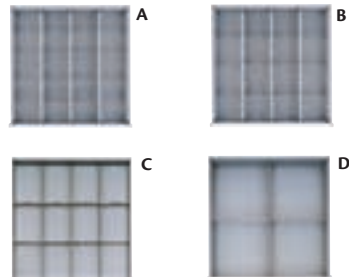

**DIVIDERS**  
 A - Drawer 1-4  
 B - Drawer 5-8  
 C - Drawer 9-10  
 D - Drawer 11

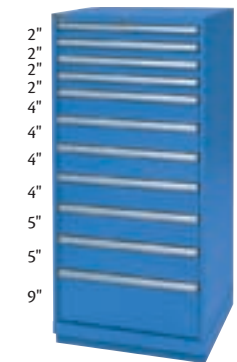



# STORAGE CABINETS

## DRAWER CABINETS



Overall Dimensions: 28 1/4" W x 28 1/2" D x 59 1/2" H  
 Number of drawers: 12  
 Number of compartments: 210  
**Model No. F1145** Bright blue  
**Model No. F1146** Light grey  
**Price/Each \$4214.00**

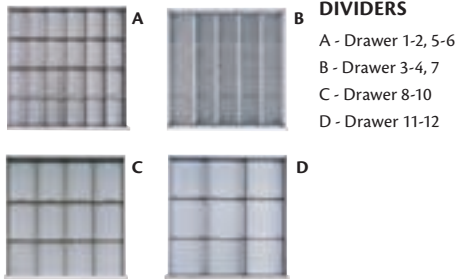

**DIVIDERS**  
 A - Drawer 1-2, 5-6  
 B - Drawer 3-4, 7  
 C - Drawer 8-10  
 D - Drawer 11-12

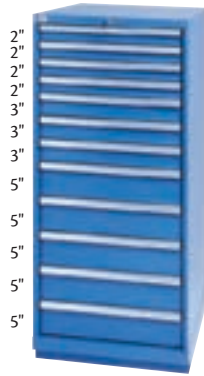

Overall Dimensions: 28 1/4" W x 28 1/2" D x 59 1/2" H  
 Number of drawers: 15  
 Number of compartments: 300  
**Model No. F1147** Bright blue  
**Model No. F1148** Light grey  
**Price/Each \$4776.00**

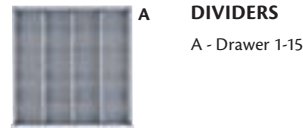

**DIVIDERS**  
 A - Drawer 1-15

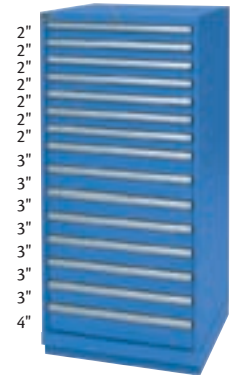

Overall Dimensions: 40 1/4" W x 22 1/2" D x 59 1/2" H  
 Number of drawers: 7  
 Number of compartments: 66  
**Model No. F1149** Bright blue  
**Model No. F1150** Light grey  
**Price/Each \$3162.00**

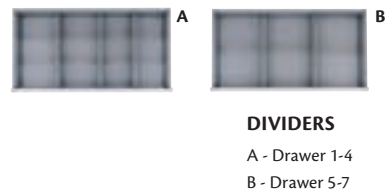

**DIVIDERS**  
 A - Drawer 1-4  
 B - Drawer 5-7

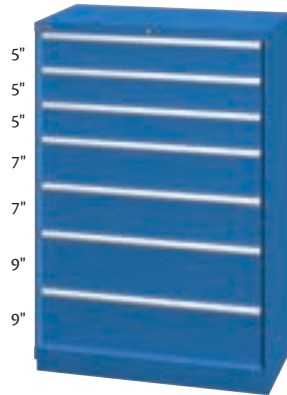

Overall Dimensions: 40 1/4" W x 22 1/2" D x 59 1/2" H  
 Number of drawers: 9  
 Number of compartments: 105  
**Model No. F1151** Bright blue  
**Model No. F1152** Light grey  
**Price/Each \$3639.00**

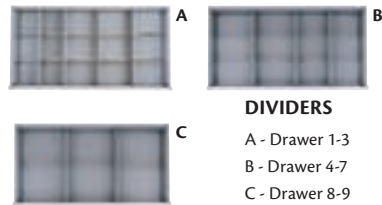

**DIVIDERS**  
 A - Drawer 1-3  
 B - Drawer 4-7  
 C - Drawer 8-9

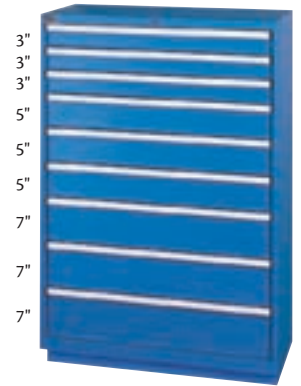

Overall Dimensions: 40 1/4" W x 22 1/2" D x 59 1/2" H  
 Number of drawers: 10  
 Number of compartments: 159  
**Model No. F1153** Bright blue  
**Model No. F1154** Light grey  
**Price/Each \$3954.00**

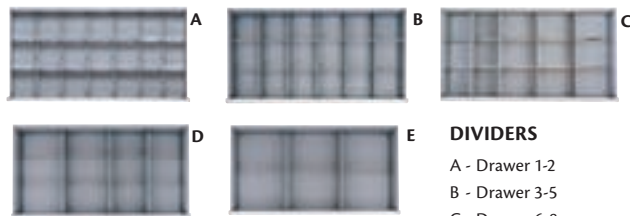

**DIVIDERS**  
 A - Drawer 1-2  
 B - Drawer 3-5  
 C - Drawer 6-8  
 D - Drawer 9  
 E - Drawer 10

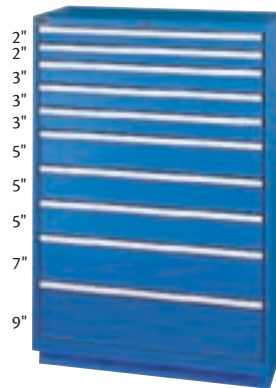

## SHELF CABINETS

Overall Dimensions: 56 1/2" W x 28 1/2" D x 33 1/2" H  
 One fixed and one adjustable shelf  
**Model No. F1157** Bright blue  
**Model No. F1158** Light grey  
**Price/Each \$1352.00**



## SHELF CABINETS

Overall Dimensions: 40 1/4" W x 22 1/2" D x 33 1/2" H  
 One fixed and one adjustable shelf  
**Model No. F1159** Bright blue  
**Model No. F1160** Light grey  
**Price/Each \$806.00**



## BUTCHER BLOCK TOPS

Fits on 28 1/4" W x 28 1/2" D cabinets  
**Model No. F1155**  
**Price/Each \$405.00**

Fits on 40 1/4" W x 22 1/2" D cabinets  
**Model No. F1156**  
**Price/Each \$405.00**



## WELDED STORAGE CABINETS

- Suitable for office, plant, school or institutional storage needs
- Fully adjustable shelves, recessed handle, cylinder lock, and coat rods (wardrobe and combination types)
- Choose from Hi-Boy, Lo-Boy, wardrobe, and combination cabinets
- Lo-Boy comes with 2 shelves
- Capacity: 150 lbs. evenly distributed



FJ863  
Lo-Boy Type



FJ856  
Hi-Boy Type

FJ867  
Wardrobe Type



FJ861  
Combination Type

Charcoal	Model No.			Description	Dimensions					Wt lbs.	Price /Each
	Beige	Black			W"	x	D"	x	H"		
FJ856	FJ864	FJ859		Hi-Boy	36	x	18	x	72	140	481.00
FJ867	FJ871	FJ865		Wardrobe	36	x	18	x	72	182	450.00
FJ861	FJ858	FJ862		Combination	36	x	18	x	72	121	537.00
FJ863	FJ870	FJ868		Lo-Boy	36	x	18	x	72	144	347.00
FJ873	FJ875	FJ876		Additional Shelf	36	x	16	x	40	90	31.40

## HEAVY-DUTY WELDED STORAGE CABINETS

- All-welded 20-gauge steel cabinet features four adjustable 18-gauge shelves, locking handle
- Shelves adjust on 2" centers
- Capacity per shelf: 300 lbs. evenly distributed
- Colour: Light grey



Model No.	Description	Dimensions W" x D" x H"	Wt. lbs.	Price /Each
FJ857	Cabinet	36 x 18 x 72	185	682.00
FJ874	Additional Shelf	36 x 18 x 1	8	59.90

## WELDED WALL HUNG CABINETS

- Suitable for areas where floor space is limited
- Dimensions: 36" W x 12" D x 30" H
- Includes: fully adjustable shelf, recessed handle and cylinder lock



Model No.	Colour	Wt. lbs.	Price /Each
FJ866	Charcoal	55	359.00
FJ872	Beige	55	364.00

## HEAVY-DUTY CABINET DOLLIES

- Makes cabinets fully mobile
- Allows for easy access during cleaning
- Two rigid and two swivel with brake, 5" poly casters
- Capacity: 800 lbs. evenly distributed
- Assembly required



Model No.	Dimensions			Price /Each
	W"	x	D"	
FJ292	36	x	18	148.00
FJ293	36	x	24	184.00
FJ294	48	x	18	172.00
FJ295	48	x	24	196.00

## ALL-WELDED DEEP HI-BOY STORAGE CABINET

- Suitable for office, plant, school or institutional storage needs
- Four fully adjustable shelves
- Includes recessed handle and cylinder lock
- Shelf capacity: 150 lbs. evenly distributed



FJ884



Model No.				Dimensions			Price /Each
Black	Beige	Charcoal		W" x D" x H"			
FJ882	FJ883	FJ884		36 x 24 x 72		581.00	
ADDITIONAL DEEP SHELF							
FJ881	FJ880	FJ879		36 x 22 x 1		67.10	

# STORAGE CABINETS

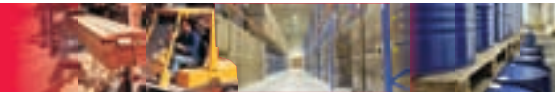

## COUNTER HIGH CABINETS

- Serves as counter and cabinet combo
- Double doors w/ three point door locking device swing to full 180°
- Quiet operating cabinet
- Two shelves, adjustable every 2"
- Cabinet dimensions: 36" W x 42" H with 18" or 21" D
- Capacity per shelf: 180 lbs.
- Shipped knocked down



**LYON**

Model No.	Description	Depth"	Wt. lbs.	Price /Each
FF985	Cabinet	18	88	833.00
FF986	Cabinet	21	96	839.00
FF987	Extra shelf (for FF985)	18	7	67.40
FF988	Extra shelf (for FF986)	21	9	65.20

## COMPACT CABINETS

- Ideal anywhere a full sized cabinet is too large
- Includes adjustable shelves
- Locking doors
- Shipped knocked down



Model No.	Dimensions W" x D" x H"	No. of Shelves	Wt. lbs.	Price /Each
FH482	21 x 15 x 35	2	33	265.00
FH483	30 x 15 x 66	4	50	445.00

## VISUAL CABINETS

- Keep a close eye on valuable inventory
- Plexiglass door panels resist breakage and will not shatter
- 22-gauge shelves, adjustable on 2" centres
- 20-gauge steel doors
- 3-point locking mechanism with die-cast locking handle (includes two keys)
- Capacity per shelf: 150 lbs.
- Shipped knocked down



Model No	Dimensions W" x D" x H"	No. of Shelves	Price /Each
MI629* FH645*	30 x 12 x 26	2	684.00
MI630 FH646	36 x 18 x 42	2	778.00
MI631 FH647	36 x 24 x 78	4	1303.00

\*Wall unit

## 48" EXTRA-WIDE ALL-WELDED CABINETS

- This cabinet offers plenty of storage space for large and small supplies
- All-welded 20-gauge steel construction
- Overall Dimensions: 48" W x 21" D x 72" H
- Capacity per shelf: 175 lbs. evenly distributed
- Includes four adjustable shelves and locking handle
- Fully assembled



Model No.	Colour	Wt. lbs.	Price /Each
FJ860	Charcoal	230	962.00
FJ869	Beige	230	962.00

## ECONOMICAL QUICK ASSEMBLY STORAGE CABINETS

- Designed for an easy assembly with fewer fasteners
- Shelves are easily adjustable on 2" centres
- One-piece base serves as an additional shelf increasing storage capacity
- Three-point locking system, with locking chrome handle and two keys, adds security
- Capacity per shelf: 100 lbs.
- Tough grey or tan powder coat finish for durability
- Shipped knocked down



Model No.	Dimensions W" x D" x H"	Wt. lbs.	Price /Each
FH643 FH648	30 x 15 x 66	88	349.00
FH649 FH650	36 x 24 x 78	130	515.00
- FH652	48 x 24 x 78	158	615.00

## HEAVY-DUTY RUBBERMAID® PLASTIC CABINETS

- Durable resin construction is easy to clean, will not rust or crack
- Functional and modular organization
- Doors are lockable (locks not included)
- Quick assembly without tools
- Ventilated shelves hold 180 lbs. each
- Shipped knocked down



Model No.	Dimensions W" x D" x H"	No. of Shelves	Wt. lbs.	Price /Each
MH722	36 x 18 x 72	3	55	451.00
MH724	36 x 18 x 37	1	28	289.00



## DEEP DOOR STORAGE CABINETS

- Padlock hasp (cannot be accessed by bolt cutters) helps secure the contents of this deep door high-density storage cabinet
- Four reinforced adjustable main shelves are complemented by six adjustable mini shelves in each 4" deep hinged door for a capacity unmatched by any other cabinet
- Padlock sold separately
- Capacity per shelf: 500 lbs evenly distributed



Special padlock hasp conceals padlocks from bolt cutters



Model No.	Description	Size	Wt. lbs.	Price /Each
		W" x D" x H"		
FB024	Cabinet	38 x 24 x 72	315	1719.00
FB025	Extra shelf for cabinet	38 x 21 1/4 x -	18	87.70
FB026	Extra shelf for door	18 x 6 x -	2	30.10
SA898	Padlock keyed different	-	-	17.00
SR892	Padlock keyed alike	-	-	18.30

## DEEP DOOR 96-BIN COMBINATION CABINETS

- All-welded heavy-duty 16-gauge combination bin/shelf cabinet
- 4" deep hinged doors
- Two reinforced 16-gauge main adjustable shelves with 500-lb. capacity per shelf
- Incorporates louvered bin hanging panels welded to the cabinet's back and doors
- Unique padlock hasp helps prevent access with bolt cutters
- Padlock sold separately
- Powder-coated Kleton grey finish
- **Bins included:**  
84 each of 4 1/8" W x 5 3/8" D x 3" H  
12 each of 5 1/2" W x 10 7/8" D x 5" H

CF373



Model No.	Description	Wt. lbs.	Price /Each
CF371	Cabinet w/Blue Plastic Bins	359	1918.00
CF372	Cabinet w/Red Plastic Bins	359	1918.00
CF373	Cabinet w/Yellow Plastic Bins	359	1918.00
CF374	Cabinet w/Green Plastic Bins	359	1918.00
CF375	Cabinet w/Stone Plastic Bins	359	1918.00

## VISIBLE STORAGE WIRE MESH CABINETS

- All-welded mesh storage cabinet provides a secure yet visible area to place your tools and equipment
- Reinforced K-Brace welded to the door frame delivers additional strength
- Diamond shaped 13-gauge steel mesh
- Adjustable shelves bolt into holes
- Door has three point latching system with cam-lock and chrome plated handle
- Dimensions: 24" W x 21" D x 72" H
- Weight: 146 lbs.

Model No. FB015  
Price/Each \$1445.00



## HEAVY GAUGE STORAGE CABINETS

- All-welded 14-gauge steel cabinets and shelves which can be adjusted every 3"
- Doors feature secure 3-point locking system
- 7-gauge welded-on legs add 4" to overall height of cabinet and provide fork lift access to move cabinet (included)
- Capacity: 1450 lbs/shelf



Model No.	Dimensions	No. of Shelves	Wt. lbs.	Price /Each
	W" x D" x H"			
FB013	36 x 21 x 78	4	370	2311.00
FB012	36 x 21 x 60	3	300	2051.00
FB011	36 x 21 x 42	2	230	1805.00

## CLEARVIEW CABINETS

- Clear polycarbonate windows so all your tools and supplies are visible at a glance
- 12-gauge one-piece body design
- 6" sweep space
- Adjustable 14-gauge shelves
- 3-point locking device
- Hinges are 10-gauge



Model No.	Dimensions	O. A. Ht"	No. of Shelves	Shelf Cap. lbs.	Wt. lbs.	Price /Each
	W" x D" x H"					
FG851	48 x 24 x 60	66	3	1200	446	2715.00
FG852	48 x 24 x 72	78	4	1200	536	2810.00

## EXTRA HEAVY-DUTY STAINLESS STEEL CABINETS

- The strongest storage product available in the market today
- Made of 12-gauge, #304 stainless steel, with a #3 finish
- Corrosion-resistant, acid-resistant, will not rust and will take the everyday abuse in an industrial environment
- Shelves adjust on 2" centers
- 3-point locking system
- 7-gauge welded legs

These units can also be found in medical, pharmaceutical, automotive, electronics, textile, breweries, marine facilities, restaurants, etc.



Model No.	Dimensions	O. A. Ht"	No. of Shelves	Shelf Cap. lbs.	Wt. lbs.	Price /Each	Extra Shelf Model No.	Price /Each
	W" x D" x H"							
FI340	36 x 24 x 60	66	3	1900	406	5414.00	FI349	204.00
FI341	36 x 20 x 72	78	4	1600	435	5839.00	FI350	215.00
FI342	36 x 24 x 72	78	4	1900	475	6238.00	FI349	204.00
FI343	48 x 24 x 60	66	3	1200	489	6511.00	FI351	249.00
FI344	48 x 24 x 72	78	4	1200	573	7344.00	FI351	249.00
FI345	60 x 24 x 60	66	3	1650	595	7703.00	FI352	377.00
FI346	60 x 24 x 72	78	4	1650	699	8734.00	FI352	377.00
FI347	72 x 24 x 60	66	3	1525	726	9141.00	FI353	558.00
FI348	72 x 24 x 72	78	4	1525	856	10431.00	FI353	558.00

# STORAGE CABINETS

## DEEP DOOR COMBINATION CABINETS

- All-welded heavy-duty 16-gauge, combination bin/shelf cabinet
- 4" deep hinged doors
- Unique padlock hasp helps prevent access with bolt cutters
- Powder coated Kleton grey finish
- Padlock sold separately

## 84-BIN CABINETS

- Four reinforced 16-gauge main adjustable shelves with 500 lbs. capacity per shelf
- Incorporates louvered bin hanging panels welded into the cabinets doors

### CABINETS ONLY

Model No.	Description	Dimensions				Wt. lbs.	Price /Each
		W"	x	D"	x H"		
CB442	Cabinet only	38	x	24	x 72	324	1638.00
FB025	Extra shelf	38	x	21 1/4	-	18	87.70

### CABINET & BIN COMBINATIONS

Blue	Red	Model No.			Description	Wt. lbs.	Price /Each
		Yellow	Green	Stone			
CB446	CB477	CB448	CB693	CB694	Cabinet and plastic bins	341	1696.00

### BINS SUPPLIED

Bin Qty.	Bin Size				Capacity lbs.
	W"	x	D"	x H"	
84	4 1/8	x	5 3/8	x 3	10

## 96-BIN CABINETS

- Two reinforced 16-gauge main adjustable shelves with 500 lbs. capacity per shelf
- Incorporates louvered bin hanging panels welded to the cabinet's back and doors

### CABINETS ONLY

Model No.	Description	Dimensions				Wt. lbs.	Price /Each
		W"	x	D"	x H"		
FH820	Cabinet only	38	x	24	x 72	316	1744.00
FB025	Extra shelf	38	x	21 1/4	-	18	87.70

### CABINET & BIN COMBINATIONS

Blue	Red	Model No.			Description	Wt. lbs.	Price /Each
		Yellow	Green	Stone			
CF371	CF372	CF373	CF374	CF375	Cabinet and plastic bins	359	1918.00

### BINS SUPPLIED

Bin Qty.	Bin Size				Capacity lbs.
	W"	x	D"	x H"	
84	4 1/8	x	5 3/8	x 3	10
12	5 1/2	x	10 7/8	x 5	30

## 98-BIN CABINETS

- Two reinforced 16-gauge main adjustable shelves with 500 lbs. capacity per shelf
- Incorporates louvered bin hanging panels welded to the cabinet's back and door

### CABINETS ONLY

Model No.	Description	Dimensions				Wt. lbs.	Price /Each
		W"	x	D"	x H"		
FH820	Cabinet Only	38	x	24	x 72	316	1744.00
FB025	Extra Shelf	38	x	21 1/4	-	18	87.70

### CABINET & BIN COMBINATIONS

Blue	Red	Model No.			Description	Wt. lbs.	Price /Each
		Yellow	Green	Stone			
CF355	CF356	CF354	CF357	CF358	Cabinet and plastic bins	385	2044.00

### BINS SUPPLIED

Bin Qty.	Bin Size				Capacity lbs.
	W"	x	D"	x H"	
48	4 1/8	x	5 3/8	x 3	10
36	4 1/8	x	7 3/8	x 3	10
8	8 1/4	x	14 3/4	x 7	60
6	16 1/2	x	14 3/4	x 7	75



KLETON



## 118-BIN CABINETS

- Incorporates louvered bin hanging panels welded to the cabinet's back and doors

### CABINETS ONLY

Model No.	Description	Dimensions				Wt. lbs.	Price /Each
		W"	x	D"	x H"		
CB441	Cabinet only	38	x	24	x 72	316	1569.00

### CABINET & BIN COMBINATIONS

Blue	Red	Model No.			Description	Wt. lbs.	Price /Each
		Yellow	Green	Stone			
CB443	CB444	CB445	CB691	CB692	Cabinet and plastic bins	385	1909.00

### BINS SUPPLIED

Bin Qty.	Bin Size				Capacity lbs.
	W"	x	D"	x H"	
42	4 1/8	x	5 3/8	x 3	10
42	4 1/8	x	7 3/8	x 3	10
18	5 1/2	x	10 7/8	x 5	30
12	8 1/4	x	14 3/4	x 7	60
4	16 1/2	x	14 3/4	x 7	75

## SHOP FURNITURE THAT'S BUILT LIKE A TANK!

There are times and environments that demand more than run-of-the-mill shop furniture. This is the time and place for Strong Hold. A line of shop furniture so durable and robust that it is accepted and demanded by industrial heavy weights. Major auto manufacturers use hundreds of these units!



A. FG816



B. FI331



C. FG830



D. FG836



E. FG838

### A. ROUGH & TOUGH STORAGE CABINETS

These heavy-duty 12-gauge steel models provide protection for valuable tools and machine parts. Built for "rough and tough" industrial use. Shelves are adjustable and more can be added for versatility.

Model No.	Width"	Depth"	Height"	O.A. Height"	Adjustable Shelves	Cabinet Wt. lbs.	Price /Each	Extra Shelf Model No.	Shelf Capacity lbs.	Price /Each
FG815	36	20	72	78	4	418	1719.00	FG820	1600	122.00
FG816	36	24	72	78	4	459	1770.00	FG821	1900	126.00
FG817	48	24	72	78	4	557	2147.00	FG822	1200	133.00
FG818	60	24	72	78	4	685	2359.00	FG823	1650	170.00
FG819	72	24	72	78	4	733	2823.00	FG824	1525	198.00

### B. HEAVY-DUTY VENTILATED STORAGE CABINETS

The 12-gauge steel doors are perforated with a diamond shape for easy visibility and ventilation. Ideal for industry, health clubs or any facility where personal belongings need to be securely locked and ventilated.

Model No.	Width"	Depth"	Height"	O.A. Height"	Adjustable Shelves	Cabinet Wt. lbs.	Price /Each	Extra Shelf Model No.	Shelf Capacity lbs.	Price /Each
FI329	36	24	72	78	4	470	2056.00	FG821	1900	126.00
FI330	48	24	72	78	4	548	2450.00	FG822	1200	133.00
FI331	60	24	72	78	4	666	2763.00	FG823	1650	170.00

### C. DOUBLE SHIFT STORAGE CABINETS

These space saving cabinets provide two separate storage compartments. Companies with a second shift can secure the first shift's valuables while the second shift is on duty. Also you can use one side for personal belongings and the other to store tools.

Model No.	Width"	Depth"	Height"	O.A. Shelf Height"	Adj. Shelf Per Each Side	Cabinet Wt. lbs.	Price /Each	Extra Shelf Model No.	Shelf Capacity lbs.	Price /Each
FG829	48	24	72	78"	4	624	2406.00	FG832	1275	68.00
FG830	60	24	72	78"	4	722	2668.00	FG833	1600	72.00
FG831	72	24	72	78"	4	813	2687.00	FG834	1950	79.00

### D. BROOM CLOSET STORAGE CABINETS

Organize your housekeeping needs with our broom closet cabinets. As heavy-duty as the rest of the Strong Hold line, double doors permit full access to all shelves. Closet side stores long handled floor care items. Use side shelves to store paper products, cleaners and brushes. Shelves can be adjusted or removed to accommodate large pails.

Model No.	Width"	Depth"	Height"	O.A. Height"	Adjustable Shelves	Cabinet Wt. lbs.	Price /Each	Extra Shelf Model No.	Shelf Capacity lbs.	Price /Each
FG835	36	24	72	78	4	477	1924.00	FG845	1025	115.00
FG836	48	24	72	78	4	567	2336.00	FG846	1375	122.00
FG837	60	24	72	78	4	669	2640.00	FG847	1750	137.00

### E. WARDROBE/STORAGE CABINETS

This cabinet fits into the heavy-duty line up as the answer to clothing storage with tools and supplies. 3-point latching mechanism adds extra protection.

Model No.	Width"	Depth"	Height"	O.A. Height"	Adjustable Shelves	Cabinet Wt. lbs.	Price /Each	Extra Shelf Model No.	Shelf Capacity lbs.	Price /Each
FG838	36	24	72	78	4	477	1971.00	FG845	1100	115.00
FG839	48	24	72	78	4	567	2371.00	FG846	1500	122.00
FG840	60	24	72	78	4	669	2683.00	FG847	1900	137.00



# STORAGE CABINETS

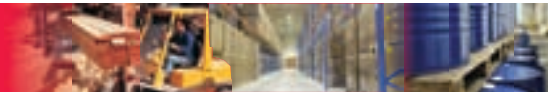

F.  
FG844



G.  
FG852

H.  
FG850



I.  
FG827

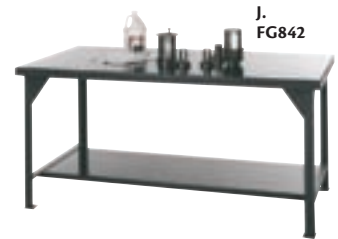

J.  
FG842

## F. CABINET SHOP DESKS

Heavy-duty shop desk, with a 29" W x 20" D and 6" H drawer. Includes a lockable hasp separate from the 3-point locking system in the cabinet doors.

Model No.	Width"	Depth"	Writing Height"	O.A. Height"	Drawer Cabinet lbs.	Cabinet Wt. lbs.	Price /Each	Extra Shelf Model No.	Shelf Capacity lbs.	Price /Each
FG844	36	28	42	54	225	380	2013.00	FG849	1050	127.00

## G. CLEARVIEW CABINETS

Keep a watchful eye on valuable items. Cabinets come equipped with clear polycarbonate windows for viewing items stored inside, without opening the doors.

Model No.	Width"	Depth"	Height"	O.A. Height"	Adjustable Shelves	Cabinet Wt. lbs.	Price /Each	Extra Shelf Model No.	Shelf Capacity lbs.	Price /Each
FG852	48	24	72	78"	4	557	2810.00	FG822	1200	133.00

## H. CORNER CABINETS

This 12-gauge all-welded corner cabinet eliminates corner clutter. Store those odd shaped tools in this space saving unit which comes with four adjustable 14-gauge shelves and a hasp for padlock. The extra wide door provides access to both sides of the corner shelves.

Model No.	Width"	Depth"	Height"	O.A. Height"	Cabinet Wt. lbs.	Price /Each	Extra Shelf Model No.	Shelf Capacity lbs.	Price /Each
FG850	48	24	72	78	1400	5316.00	FG854	795	257.00

## I. COUNTER TOP STORAGE CABINETS

Counter top units provide ample storage for heavy tools and supplies on two adjustable shelves. These space saving units are sold without legs. Most frequently they are placed on a table to bring the storage up to a working height. Drawers or casters can be added as options.

Model No.	Width"	Depth"	Height"	O.A. Height"	Cabinet Wt. lbs.	Price /Each	Extra Shelf Model No.	Shelf Capacity lbs.	Price /Each
FG825	24	20	36	36	180	1147.00	FG828	1000	102.00
FG826	36	20	36	36	235	1423.00	FG820	1600	122.00
FG827	36	20	42	42	260	1505.00	FG820	1600	122.00

## J. SHOP TABLES

Tables designed to meet virtually every strength requirement for heavy manufacturing. Tops are 7-gauge steel and legs are from 2" x 2" x 1/4" angle.

Model No.	Width"	Depth"	O.A. Height"	Capacity lbs	Wt. lbs.	Price /Each
FG841	48	30	34	5500	211	942.00
FG842	72	36	34	10 000	350	1078.00

## THE INDESTRUCTIBLE!

- ✓ Will not break, bend or split even after repeated overstrikes
- ✓ Ergonomic rubber grip absorbs impact, reducing user fatigue

Model TYB497  
See page 1365

## HEAVY-DUTY CABINET DOLLIES

- Makes cabinets fully mobile
- Allows for easy access during cleaning
- Two rigid and two swivel with brake, 5" poly casters
- Capacity: 800 lbs. evenly distributed
- Assembly required

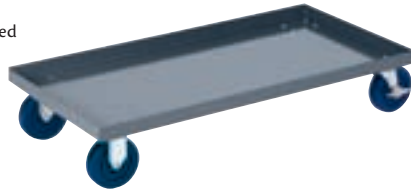

Model No.	Dimensions			Price /Each
	W"	x	D"	
FI292	36	x	18	148.00
FI293	36	x	24	184.00

## PROMAXX™ MODULAR STORAGE SYSTEM

- Modular design allows you to combine these durable steel units to fit any workspace and storage need
- Perfect addition to work shops, warehouses, maintenance areas and factories
- Heavy-duty steel construction ensures that these units will provide long lasting service
- Two-tone silvervein and black textured powder coat finish helps to conceal dirt and grease helping to make your work area appear cleaner
- Shipped knocked down



### PROMAXX™ WALL CABINETS

- Mounts easily to any wall in your work area
- Recessed welded steel handle and built-in lock provides for added storage security
- Dimensions: 30" W x 12" D x 30" H
- Includes: Adjustable internal shelf on 2" centers
- Weight: 50 lbs.
- Capacity: 100 lbs. evenly distributed

Model No. FH731  
Price/Each \$435.00



### PROMAXX™ INDUSTRIAL STORAGE CABINETS

- Chrome locking handle combined with three-point locking system provides security for your stored items
- Dimensions: 36" W x 18" D x 72" H
- Includes: Four shelves adjustable on 2" centres to store a variety of sized products
- Capacity per shelf: 125 lbs. evenly distributed
- Weight: 115 lbs.
- Shipped knocked down

Model No. FH734  
Price/Each \$595.00



## WORKBENCHES



	Model No.	Size W" x L"	Wt. lbs.	Price /Each
<b>STEEL - WOOD FILL</b>				
	FF672	36 x 72	164	435.00
	FF671	36 x 60	156	399.00
	FF670	30 x 72	166	399.00
	FF669	30 x 60	146	374.00
	FF667	24 x 60	110	366.00
<b>LAMINATED WOOD - BULLNOSE EDGE</b>				
	FF658	36 x 72	171	679.00
	FF657	36 x 60	149	659.00
	FF656	30 x 72	150	629.00
	FF655	30 x 60	130	559.00
	FF653	24 x 60	106	499.00
<b>SHOP TOPS</b>				
	FF679	36 x 72	171	476.00
	FH877	36 x 60	157	423.00
	FF677	30 x 72	150	412.00
	FF676	30 x 60	133	368.00
	FH878	24 x 60	111	346.00
<b>PLASTIC LAMINATE</b>				
	FF665	36 x 72	171	562.00
	FH879	36 x 60	152	491.00
	FF663	30 x 72	150	480.00
	FF662	30 x 60	133	425.00
	FH880	24 x 60	108	399.00

Note: Also available in 304 stainless steel top

### PROMAXX™ MOBILE 2-DOOR CABINETS

- Rubber mat on top to protect tools and keep items from rolling off
- Recessed welded steel handle and three-point locking system with built-in lock for secure storage
- Four heavy-duty casters provide for easy mobility
- Dimensions: 28" W x 22" D x 30" H
- Includes: One interior fixed shelf
- Capacity: 400 lbs. evenly distributed
- Weight: 80 lbs.
- Shipped knocked down

Model No. FH732  
Price/Each \$539.00



### PROMAXX™ MOBILE TOOL CABINETS

- Protective drawer liners and rubber mat on top protects tools, and prevents them from rolling around
- Three drawers with premium ball-bearing slides for smooth drawer operation
- Single key lock securely locks all drawers at once
- Four heavy-duty casters for increased mobility
- Dimensions: 23" W x 22" D x 30" H
- Capacity: 400 lbs. evenly distributed
- Weight: 90 lbs.
- Shipped knocked down

Model No. FH733  
Price/Each \$679.00



# LOCKERS

## LOCKERS APPLICATION GUIDE

Refer to this chart to find the most suitable lockers for your project. If you require any assistance make sure to contact your material handling specialists today, they can help you through each step from design layout to realization.

### LEGEND

- ✓ Preferred
- ▲ Suitable
- ◆ Contact your Material Handling Specialist
- \* Preferred use with an elevated base



	Knocked Down Lockers	Standard Lockers	Heavy-Duty Concorde™	Perforated Locker	Standard Gear Locker	Deluxe Gear Locker	Polyethylene Locker	Plastic Locker
<b>SCHOOLS</b>								
Elementary	▲	▲	▲	▲	▲	◆	✓	▲
Corridor	▲	▲	✓	▲	▲	◆	✓	◆
Gym	▲	▲	▲	✓	✓	◆	✓	▲
Team Room	▲	▲	▲	✓	✓	◆	✓	▲
Employee	✓	✓	▲	▲	◆	◆	▲	◆
<b>RECREATION</b>								
Recreation Centre	▲	▲	✓	▲	▲	◆	✓	✓
Health Club	▲	▲	✓	▲	▲	◆	✓	✓
Country Club	▲	▲	✓	▲	▲	◆	✓	◆
<b>COMMERCIAL/INDUSTRY</b>								
Employee	✓	✓	▲	▲	▲	▲	✓	◆
Equipment/Tools	▲	▲	✓	◆	▲	✓	◆	◆
<b>PUBLIC SERVICE</b>								
Police	◆	◆	▲	▲	✓	✓	▲	◆
Fire/Rescue	▲	▲	✓	✓	✓	✓	▲	◆
Military	◆	◆	▲	▲	✓	✓	▲	◆
<b>HEALTH CARE</b>								
Changing Room	✓	✓	▲	▲	✓	▲	✓	▲
Employee	✓	✓	▲	▲	✓	▲	✓	▲
<b>FOOD INDUSTRY</b>								
Restaurants	*	*	*	*	◆	◆	✓	✓
Manufacturing Plants	*	*	*	*	◆	◆	✓	✓

## STANDARD WELDED GEAR LOCKERS

- Gear lockers are ideal for athletic team rooms, fire fighter's equipment or any other application where easy access to uniforms and/or equipment is required
- Open face and perforated sides make these lockers fully accessible and ventilated
- Lockable safety box and foot locker allows for safely storing of valuable goods
- Lower shelf functions as a bench which eliminates the need for locker room benches
- **Base model includes:** Safety box, upper shelf and coat bar



FJ897



Model No.			Dimensions W" x D" x H"	Wt. lbs.	Price /Each
Light Grey	Beige	Red			
<b>BASE MODELS</b>					
FJ895	FJ894	FJ896	24 x 24 x 72	240	639.00
FJ901	FJ900	FJ902	30 x 24 x 72	251	656.00
FJ907	FJ906	FJ908	36 x 24 x 72	278	673.00
<b>W/FOOT LOCKER &amp; LOWER SHELF</b>					
FJ898	FJ897	FJ899	24 x 24 x 72	280	768.00
FJ904	FJ903	FJ905	30 x 24 x 72	296	785.00
FJ910	FJ909	FJ911	36 x 24 x 72	328	803.00

## DELUXE WELDED GEAR LOCKERS

- Deluxe gear lockers provide security with optimum ventilation for valuable equipment and uniforms
- Wardrobe design interior provides the flexibility to store all different kinds of materials and clothing
- Lower lateral drawer allows you to stow heavier bulky items such as boots or gear bags
- **Base model includes:** Three half shelves, one full width shelf, coat bar and lockable doors

FJ914



Model No.			Dimensions W" x D" x H"	Wt. lbs.	Price /Each
Light Grey	Beige	Red			
<b>BASE MODELS</b>					
FJ913	FJ912	FJ914	36 x 24 x 72	407	1053.00
<b>W/LATERAL DRAWER</b>					
FJ916	FJ915	FJ917	36 x 24 x 72	527	1285.00



## READY TO ASSEMBLE STEEL LOCKERS

- Ships knocked down, ready to assemble with nuts and bolts included
- 16-gauge frames, 24-gauge body and shelves
- Durable powder-coated grey paint finish
- Number plates available separately
- Single tier dimensions: 12" W x 18" D x 72" H
- Double tier height: 33 1/4"
- Lockerettes height: 11"

KLETON



16-gauge frames,  
24-gauge body and  
shelves



Three zinc-plated coat  
hooks and one shelf  
included in single and  
double tier lockers



Stainless steel  
recessed padlock  
handles



Double pan construction  
doors, 20-gauge outer  
and 24-gauge inner pans  
(single & double tier)



### SLOPE TOP

- Helps eliminate dust build up
- Raises top by 10"



### RECESSED BASE

- Prevents liquids from entering the locker
- Raises locker 4" off the ground



### SINGLE TIER

Model No.	Bank of	Wt. lbs.	Price /Each
<b>BASIC STYLE</b>			
FL362	1	52	189.00
FL363	2	96	329.00
FL364	3	139	495.00
<b>W/SLOPE TOP</b>			
FL380	1	56	204.00
FL381	2	104	367.00
FL382	3	151	549.00
<b>W/RECESSED BASE</b>			
FL392	1	56	204.00
FL393	2	104	364.00
FL394	3	151	549.00
<b>W/SLOPE TOP &amp; RECESSED BASE</b>			
FL404	1	60	224.00
FL405	2	112	399.00
FL406	3	163	595.00

### DOUBLE TIER

Model No.	Bank of	Wt. lbs.	Price /Each
<b>BASIC STYLE</b>			
FL366	1	54	219.00
FL367	2	98	379.00
FL368	3	141	569.00
<b>W/SLOPE TOP</b>			
FL384	1	57	239.00
FL385	2	106	409.00
FL386	3	153	619.00
<b>W/RECESSED BASE</b>			
FL396	1	57	239.00
FL397	2	106	399.00
FL398	3	153	599.00
<b>W/SLOPE TOP &amp; RECESSED BASE</b>			
FL408	1	61	249.00
FL409	2	114	439.00
FL410	3	165	639.00

### LOCKERETTES

Model No.	Bank of	Wt. lbs.	Price /Each
<b>BASIC STYLE</b>			
FL370	1	56	319.00
FL371	2	112	599.00
FL372	3	168	899.00
<b>W/SLOPE TOP</b>			
FL388	1	60	329.00
FL389	2	120	629.00
FL390	3	180	949.00
<b>W/RECESSED BASE</b>			
FL400	1	60	329.00
FL401	2	120	629.00
FL402	3	180	939.00
<b>W/SLOPE TOP &amp; RECESSED BASE</b>			
FL412	1	64	339.00
FL413	2	128	659.00
FL414	3	192	979.00

### ACCESSORIES

Model No.	Description	Price /Each
FL375	10" Slope Top	19.95
FL374	4" Recessed Base	19.95
FL376	Nuts & Bolts, Set of 1	1.25
FL518	Number Plates (Set of 1 to 25)	19.95
FL519	Number Plates (Set of 26 to 50)	19.95
FL520	Number Plates (Set of 51 to 75)	19.95
FL521	Number Plates (Set of 76 to 100)	19.95

# LOCKERS

## CLEAN LINE™ ECONOMY LOCKERS

- Fully assembled, prime grade cold rolled steel locker
- All-welded frame with panels and doors assembled with pop rivets
- 20-gauge double pan construction doors, 16-gauge frames, 24-gauge bodies and shelves
- Dimensions: 12" W x 18" D x 72" H
- Single tier locker includes:**  
One hat shelf, three coat hooks and aluminum recessed padlock handle
- Double and Triple lockers include:**  
Two coat hooks per opening and aluminum recessed padlock handle
- High quality baked on enamel standard pearl grey paint (beige also available)



### SLOPE TOP

Slope top prevents the collection of debris and is easier to maintain against the accumulation of dust



### RECESSED BASE

Raises locker 4" off the floor

Ventilation holes on frame cross piece

20-gauge steel doors

16-gauge steel frame

Aluminum recessed padlock handle



Bank of 1



Bank of 2



Bank of 3



Bank of 4



### SINGLE TIER LOCKERS

Model No.	Bank of	Wt. lbs.	Price /Each
<b>BASIC STYLE</b>			
FJ151	1	45	209.00
FJ152	2	90	379.00
FJ153	3	135	549.00
FJ154	4	180	729.00
<b>W/SLOPE TOP</b>			
FJ176	1	47	239.00
FJ177	2	92	419.00
FJ178	3	137	621.00
FJ179	4	182	815.00
<b>W/RECESSED BASE</b>			
FJ224	1	47	239.00
FJ225	2	92	419.00
FJ226	3	137	621.00
FJ227	4	182	815.00
<b>W/SLOPE TOP &amp; RECESSED BASE</b>			
FJ200	1	49	259.00
FJ201	2	94	460.00
FJ202	3	139	689.00
FJ203	4	184	921.00
<b>W/PERFORATED DOORS</b>			
FJ478	1	45	231.00
FJ479	2	90	418.00
FJ480	3	135	619.00
FJ481	4	180	794.00

### DOUBLE TIER LOCKERS

Model No.	Bank of	Wt. lbs.	Price /Each
<b>BASIC STYLE</b>			
FJ155	1	48	233.00
FJ156	2	94	429.00
FJ157	3	138	619.00
FJ158	4	183	825.00
<b>W/SLOPE TOP</b>			
FJ180	1	50	259.00
FJ181	2	96	469.00
FJ182	3	139	685.00
FJ183	4	184	909.00
<b>W/RECESSED BASE</b>			
FJ228	1	50	259.00
FJ229	2	96	469.00
FJ230	3	139	685.00
FJ231	4	184	909.00
<b>W/SLOPE TOP &amp; RECESSED BASE</b>			
FJ204	1	52	279.00
FJ205	2	98	510.00
FJ206	3	141	758.00
FJ207	4	186	999.00
<b>W/PERFORATED DOORS</b>			
FJ482	1	48	259.00
FJ483	2	94	471.00
FJ484	3	138	719.00
FJ485	4	183	930.00

### TRIPLE TIER LOCKERS

Model No.	Bank of	Wt. lbs.	Price /Each
<b>BASIC STYLE</b>			
FJ159	1	50	279.00
FJ160	2	96	563.00
FJ161	3	140	805.00
FJ162	4	185	1050.00
<b>W/SLOPE TOP &amp; RECESSED BASE</b>			
FJ208	1	54	334.00
FJ209	2	100	655.00
FJ210	3	143	929.00
FJ211	4	188	1218.00
<b>W/PERFORATED DOORS</b>			
FJ486	1	50	329.00
FJ487	2	96	630.00
FJ488	3	140	945.00
FJ489	4	185	1261.00
<b>FREE STANDING BASE</b>			
• Ideal for making the underneath of your lockers accessible for cleaning			
• Overall height of 6"			
• Constructed of 14-gauge steel legs and 16-gauge steel frame			
• Grey			
			
FJ931			
<b>Model No.</b>			
<b>For Bank of</b>			
<b>Wt. lbs.</b>			
<b>Price /Each</b>			
FJ931	1	5	33.50
FJ932	2	8	67.10
FJ933	3	12	101.00
FJ934	4	15	134.00

### LOCKERETTES

Model No.	Bank of	Wt. lbs.	Price /Each
<b>BASIC STYLE</b>			
FJ171	1	50	337.00
FJ172	2	96	645.00
FJ173	3	140	969.00
FJ174	4	180	1386.00
<b>W/PERFORATED DOORS</b>			
FJ490	1	50	393.00
FJ491	2	96	773.00
FJ492	3	140	1160.00
FL353	4	180	1547.00

### ACCESSORIES

Model No.	Description	Price/Each
FJ930	Cylinder Lock	22.40
FJ685	Coat Rod	17.90

## ALL-WELDED CONCORDE™ LOCKERS

- All-welded heavy-duty cold-rolled steel construction
- Dimensions: 12" W x 18" D x 72" H
- 16-gauge door frame
- 20-gauge double wall door with ventilation
- 11-gauge hasp with easy padlock accessibility
- **Single tier lockers include:**
  - One hat shelf and three coat hangers
- **Double and triple lockers include**
  - two coat hooks per opening
- Coat hoods are rounded and polished to avoid damage to clothing
- Magnetic latch for secure door closing
- Contemporary style ventilated louvers (12 holes of 1" x 1/4") on each door
- High quality baked on enamel charcoal grey paint (light grey and beige also available)



Magnet in door strike ensures doors will remain closed

Full length handle

Incorporated ventilation on the doors

20-gauge double panelled door

14-gauge hinge

22-gauge galvanised steel bottom



Bank of 1

Bank of 2

Bank of 3

Bank of 4



Slope top



Recessed base



### SINGLE TIER LOCKERS

Model No.	Bank of	Wt. lbs.	Price /Each
<b>BASIC STYLE</b>			
FJ783	1	64	255.00
FJ784	2	119	447.00
FJ785	3	174	630.00
FJ786	4	229	836.00
<b>W/SLOPE TOP</b>			
FJ787	1	68	291.00
FJ788	2	127	514.00
FJ789	3	186	731.00
FJ790	4	245	970.00
<b>W/RECESSED BASE</b>			
FJ791	1	68	291.00
FJ792	2	127	514.00
FJ793	3	186	731.00
FJ794	4	245	970.00
<b>W/SLOPE TOP &amp; RECESSED BASE</b>			
FJ795	1	72	324.00
FJ796	2	135	581.00
FJ797	3	198	831.00
FJ798	4	261	1105.00

### DOUBLE TIER LOCKERS

Model No.	Bank of	Wt. lbs.	Price /Each
<b>BASIC STYLE</b>			
FJ799	1	65	313.00
FJ800	2	121	563.00
FJ801	3	176	771.00
FJ802	4	231	1019.00
<b>W/SLOPE TOP</b>			
FJ803	1	69	347.00
FJ804	2	129	630.00
FJ805	3	188	872.00
FJ806	4	247	1289.00
<b>W/RECESSED BASE</b>			
FJ807	1	69	347.00
FJ808	2	129	630.00
FJ809	3	188	872.00
FJ810	4	247	1154.00
<b>W/SLOPE TOP &amp; RECESSED BASE</b>			
FJ811	1	73	380.00
FJ812	2	137	698.00
FJ813	3	200	972.00
FJ814	4	300	1287.00

### TRIPLE TIER LOCKERS

Model No.	Bank of	Wt. lbs.	Price /Each
<b>BASIC STYLE</b>			
FJ815	1	66	358.00
FJ816	2	122	670.00
FJ817	3	178	944.00
FJ818	4	233	1229.00
<b>W/SLOPE TOP</b>			
FJ823	1	70	392.00
FJ824	2	130	737.00
FJ825	3	190	1043.00
FJ826	4	249	1364.00
<b>W/RECESSED BASE</b>			
FJ819	1	70	392.00
FJ820	2	130	737.00
FJ821	3	190	1043.00
FJ822	4	249	1364.00
<b>W/SLOPE TOP &amp; RECESSED BASE</b>			
FJ827	1	74	424.00
FJ828	2	138	805.00
FJ829	3	202	1144.00
FJ830	4	265	1497.00

### LOCKERETTES

Model No.	Bank of	Wt. lbs.	Price /Each
<b>BASIC STYLE</b>			
FK872	1	64	514.00
FK873	2	119	995.00
FK874	3	174	1420.00
FK875	4	229	1900.00



# LOCKERS

## 16-DOOR ARCHETTES

- Ideal for confined spaces
- 16 lockable compartments
- Bar for hanging garments
- Compartment dimensions: 12" W x 18" D x 12" H
- Overall dimensions: 72" W x 18" D x 72" H
- Padlock hasp



Model No.	Description	Colour	Wt. lbs.	Price/Each
FJ175	Pop Rivet Assembled	Light Grey	165	1170.00
FL359	All-Welded	Light Grey	180	1319.00
FL360	All-Welded	Charcoal	180	1319.00

## LOCKER ROOM BENCHES

- Necessary for any locker room
- Features black powder coated legs that can be used free-standing, or bolted to the floor (wood-top locker benches)



Model No.	Dimensions			Type	Wt. lbs.	Price /Each
	L" x W" x H"					
FB002	72 x 12 x 17			Steel	35	266.00
RL871	48 x 9 1/4 x 16 1/2			Wood	23	266.00
RL872	60 x 9 1/4 x 16 1/2			Wood	29	282.00
RL873	72 x 9 1/4 x 16 1/2			Wood	31	311.00
RL874	96 x 9 1/4 x 16 1/2			Wood	39	371.00

## PERSONAL EFFECTS LOCKERS

- Effective security system for storage of uniforms, linens, protective clothing, personal items, etc.
- Up to 16 people can have security of their own individual compartment
- Authorized personnel can open large master door with one key, for uniform replacement/security problems
- Compact design saves space
- All models finished in durable dove grey enamel
- Shipped assembled

**LYON**



FC063



FC064



FC066

Model No.	No. of Compartments	Overall Dimensions W" x D" x H"	Wt. lbs.	Price /Each
FC063	9	24 x 15 x 84	122	1774.00
FC064	10	18 x 15 x 78	91	1543.00
FC066	16	18 x 15 x 78	106	2165.00

## WALL HUNG LOCKERS

- All-in-one storage for clothing and personal effects
- Four compartments measuring 12" W x 18" D x 12" H
- Baked enamel grey finish



Model No.	Description	Colour	Price/Each
FJ919	Pop Rivet Assembled	Light Grey	499.00
FL357	All-Welded	Light Grey	509.00
FL358	All-Welded	Charcoal	509.00

## POLYPROPYLENE FOLDING BENCHES

- Durable high-density polypropylene construction
- Steel framing and folding legs for extra strength
- Dimensions: 72" L x 12" W x 17" H
- Folded dimensions: 36" L x 12" W x 4" H
- Weight: 20 lbs.

Model No. ON699  
Price/Each \$109.00



## LENOX™ HIGH-DENSITY POLYETHYLENE LOCKERS

Quick installation and low maintenance costs can add up to significant life cycle cost savings with Lenox™ solid plastic lockers. An added benefit of this fully assembled locker is that it is backed by a 20-year warranty and made from 30% post-industrial recycled material. In terms of durability, versatility and product life, most other lockers fall short.

### Benefits:

- Impervious to moisture: Will not rust, delaminate, mildew or absorb odours
- Colour goes all the way through the material: Lenox™ lockers never need painting and scratches are repaired easily
- Highly impact resistant: Virtually eliminates dents and broken doors
- Vandalism resistant: Graffiti is no match for these lockers, it can easily be wiped away with use of regular cleaners
- Confidence in durability: All Lenox™ lockers are backed with a 20-year manufacturer's limited warranty against rust, denting and delaminating under normal use

### Available Options:

- Key Locks
- Bases
- Mesh Doors
- Keypad Locks
- Number Plates
- Filler Panels
- Metal Wall Hooks
- Slope Tops
- Plastic Mirrors
- Engraved Logos
- 5 Heights
- Plastic Coat Hooks
- Pedestal Benches
- Drain Holes
- 100% Recycled Content Lockers
- 21 Colours
- 3 Widths & Depths
- Bench Lockers
- Built-In Combination Locks
- Card-Operated Locks
- End Panels



FI108      FI112      FI116      FI120

**Single Tier**  
12" W x 12" D x 60" H  
**Model No. FI108**  
**Price/Each \$805.00**

**Double Tier**  
12" W x 12" D x 72" H  
**Model No. FI112**  
**Price/Each \$917.00**

**Triple Tier**  
12" W x 12" D x 72" H  
**Model No. FI116**  
**Price/Each \$954.00**

**Four Tier**  
12" W x 12" D x 72" H  
**Model No. FI120**  
**Price/Each \$982.00**

**Other sizes available, call for pricing:**  
**Width:** 12", 15", 18"  
**Depth:** 12", 15", 18"  
**Height:** 24", 36", 48", 60", 72"



**20-YEAR LIMITED WARRANTY\***



**Mesh Doors**  
Optimal ventilation.



**Cubby Lockers**  
Three cubby lockers pictured.



**Bench Lockers**  
Convenient seating and secure storage.

### LENOX™ Z-LOCKER

The Z-Locker is a multi-height solid plastic locker with a unique design that allows for hanging articles of clothing wrinkle-free while conserving valuable floor space.

### Benefits:

- Unique locker design provides practical multi-tiered storage in half of the floor space
- Allows you to double the amount of available lockers while still providing wrinkle-free storage for garments



**CUSTOM ENGINEERED DRAWINGS LAID OUT TO YOUR FLOOR PLAN!**



### AVAILABLE COLOURS



# LOCKERS

## PLASTIC LOCKERS

### A NEW GENERATION OF LOCKERS

- These plastic lockers are maintenance free
- Drain holes make them easy to clean, just hose them down with soap and water
- Durable plastic construction makes them perfect for wet environments: food processing plants, athletic facilities, etc.
- New optional clear door design allows for easy inspection of locker contents

### Specifications:

- Rust-proof
- No need for painting
- Easy cleaning
- Durable polyethylene construction
- Each unit is fully assembled
- Easy installation
- Space saving design
- Maintenance free

**REMCON  
PLASTICS**  
INCORPORATED

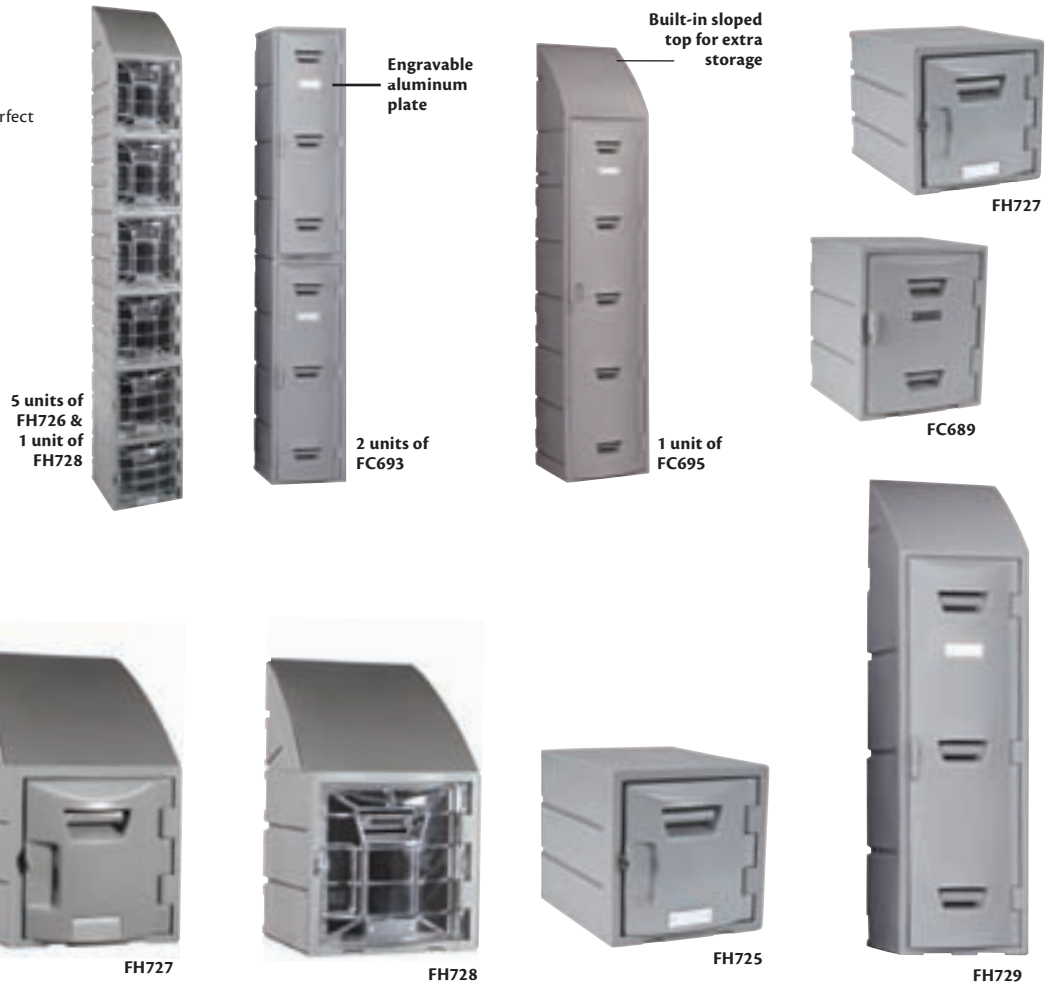

Model No.	Description	Dimensions W" x D"	Door Colour	Hook	Shelf	Top	Wt. lbs.	Price /Each
FH725	12" H locker (usually stacked 6 units high)	12 x 15	Grey	No	No	Flat	6	142.00
FH726	12" H locker (usually stacked 6 units high)	12 x 15	Clear	No	No	Flat	6	218.00
FH727	12" H locker (Sloped top)	12 x 15	Grey	No	No	Slope	8	155.00
FH728	12" H locker (Sloped top)	12 x 15	Clear	No	No	Slope	8	228.00
FC689	18" H locker (usually stacked 4 units high)	15 x 15	Grey	No	No	Flat	10	193.00
FC691	18" H locker (Sloped top)	15 x 15	Grey	No	No	Slope	45	224.00
FC693	36" H locker (usually stacked 2 units high)	12 x 15	Grey	Yes	No	Flat	16	259.00
FC695	Full size 60" H locker	15 x 18	Grey	Yes	Yes	Slope	42	615.00

**Note:** All dimensions and weight are nominal and may vary due to molding tolerances. Mounting hardware not included. Lockers are individually sold per opening.

## MASTERLOCK COMBINATION PADLOCKS

- World's best selling combination lock
- Hardened steel shackle for extra cut resistance
- Combination security for keyless convenience
- Double-armored stainless steel body
- 3-digit dialing and 1500 combinations for maximum security
- Model SR914 are school standard's in combination padlocks



**BLACK  
GUARD**  
Anti-Shim Technology

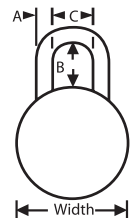

Model No.	Mfg. No.	Body Size		Body Material	Shackle Clearance			Shipping Weight (lbs.)	Price /Each
		Width"	Thickness"		A"	B"	C"		
SR914	1500	1 7/8 Dia.	3/4	Stainless Steel	9/32	3/4	13/16	0.50	8.18
SAL506	1500LH	1 7/8 Dia.	3/4	Stainless Steel	9/32	2	13/16	0.50	12.40



**KLETON**



# CANADA'S LEADING MATERIAL HANDLING SUPPLIER

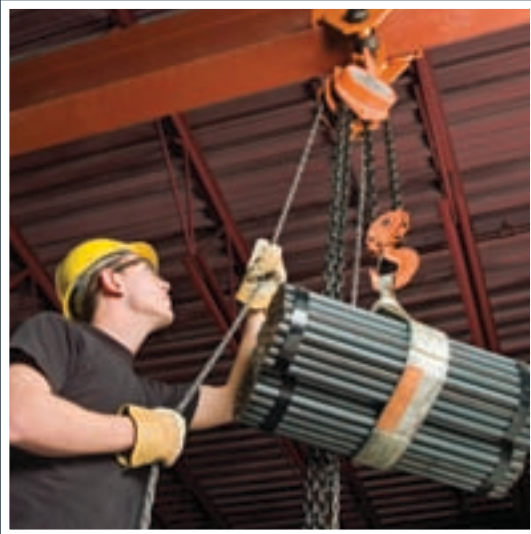

# WORKBENCHES

## CREATE A WORKBENCH DESIGNED FOR YOUR APPLICATION

- Select from the components below to build the workbench to fit your needs
- All components **required** to make up your workbench are on this page
- **Optional** features for enhanced functionality are on the following page
- All steel components are constructed of 14-gauge steel unless otherwise specified
- All mounting hardware included
- Capacities range from 1000 lbs. to 2500 lbs. evenly distributed
- All steel components are powder coated Kleton grey
- Shipped knocked down

### THINGS TO CONSIDER WHEN ORDERING A WORKBENCH

1. Determine the size (length, width, height) of the workbench required
2. Select one of each of the required components listed on this page, respecting the determined size of the workbench



## REFER TO PAGES 118 AND 119 FOR YOUR ABOVE-WORKBENCH WORKSTATION

### A - LEGS

- Legs static or mobile
- Comes with knockout for standard two-outlet electrical plug
- Provides an overall height of 34" w/top



Model No.	Description	Dimensions			Wt. lbs.	Price /Each
		D"	x	H"		
ML264	Single leg for use w/ 24" D top	22	x	32	14	71.50
ML265	Single leg for use w/ 30" D or 36" D top	28	x	32	15	78.40
ML266*	Pair of legs for use w/24" D top, includes Stringer FF979	22	x	32	38	150.00
ML268*	Pair of legs for use w/30" D or 36" D top, includes Stringer FF979	28	x	32	45	150.00
ML267*	Mobile Kit for use w/24" D top (pair), includes Stringer FF979	22	x	32	40	309.00
ML269*	Mobile Kit for use w/30" D or 36" D top (pair), includes Stringer FF979	28	x	32	40	290.00
FG732	Leg extensions to make height adjustable from 34"-39" in 1" increments (set of 4)				8	106.00

\*For 84" L & 96" L tops, see the Universal Stringers listed below

### B - TOPS

A variety of tops are available: 14-gauge steel wood filled, laminated wood, shop top and plastic laminate in a variety of sizes.

Our complete list of tops can be found on page 115



Wood Top - Square Edge



Wood Top - Bullnose



Shop Top



Plastic Laminate

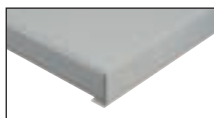

Steel Wood-Filled

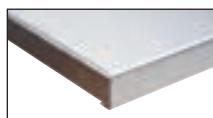

Stainless Steel Wood-Filled

### C - UNIVERSAL STRINGERS

- Adds stability to the workbench
- Prevents legs from shifting
- Weight: 11lbs.

Model No. FF979 For 48", 60" or 72" bench  
(included in kits ML266 to ML269)  
Price/Each \$47.10

Model No. FH925 For 84" bench  
Price/Each \$72.10

Model No. FH926 For 96" bench  
Price/Each \$85.60



**CUSTOMIZE YOUR WORKBENCH WITH ANY OF THE FOLLOWING OPTIONS:**



### D - DRAWERS

- Add storage to any workbench
- All-welded heavy-gauge steel
- 100% full extension with ball bearing slide mechanism
- Equipped with locks and two keys
- All locks keyed alike by drawer model
- Custom key options available
- Capacity: 100 lbs. per drawer evenly distributed
- Aluminum extrusion handles with grey end caps
- Overall Dimensions: 18" W x 21" D x 9" H



### SINGLE DRAWER UNITS

- (1) 15 3/8" W x 20" D x 5 5/8" H
- Model No. FH673**  
**Price/Each \$171.00**

### DOUBLE DRAWER UNITS

- (2) 15 3/8" W x 20" D x 2 3/4" H
- Model No. FH674**  
**Price/Each \$250.00**

### E - BENCH RISER SHELVES

- Increase storage space
- Ideal for getting tools and other equipment off work surfaces
- 9" D x 12" H
- One per workbench



Model No.	Overall Width"	Wt. lbs.	Price/Each
FF956	48	19	106.00
FF957	60	24	109.00
FF958	72	29	119.00
FI319	84	35	178.00
FI320	96	42	234.00

### F - LOWER SHELVES

- Add extra storage to any workbench
- 9" D
- One or two 9" deep shelves can be used per workbench



Model No.	Overall Width"	Wt. lbs.	Price/Each
FF934	44 (for use with 48" top)	14	58.70
FF935	56 (for use with 60" top)	16	68.00
FF936	68 (for use with 72" top)	18	69.90
RL866	80 (for use with 84" top)	21	85.60
RL867	92 (for use with 96" top)	24	104.00

### G - BACK STOPS

- Add a 3" edge to the back of any workbench
- One per bench top



Model No.	Overall Width"	Wt. lbs.	Price/Each
FF704	48	8	44.90
FF705	60	10	51.80
FF708	72	12	69.90
FI317	84	14	85.60
FI318	96	16	99.50

### H - END STOPS

- Add 3" sides to any workbench
- One per side desired to enclose



Model No.	Overall Width"	Wt. lbs.	Price/Each
FF792	24	4	29.50
FF793	30	5	34.50
FF794	36	6	36.00



**We try to make it easy... look at our pre-designed layout options on pages 116 and 117**

Customize to your specifications. If you need specific sizes or requirements not available on this page, call us today with your specs!



# WORKBENCHES

Customize your own workbench... simply select any two cabinets listed and add a top.

## CABINETS

- All-welded heavy-gauge steel
- 100% full extension drawers with ball bearing slide mechanism
- Capacity: 100 lbs. per drawer evenly distributed
- Reversible doors, can be opened on either left or right side
- Optional bases add height in 4" increments (maximum two bases per pedestal)
- Aluminum extrusion handles with grey end caps
- Complete with locks and two keys
- All locks keyed alike for pedestal model
- Custom key options available
- 18" W x 21" D x 28" H, overall cabinet size
- 30" overall height with top
- Powder coat finish with grey shell and Kleton blue on doors and drawers



REFER TO PAGES 118 AND 119 FOR YOUR ABOVE-WORKBENCH WORKSTATION



### FULL DOOR CABINETS

- 16 3/4" W x 21" D x 24" H
  - Internal adjustable shelf included
  - Weight: 48 lbs.
- Model No. FH666**  
**Price/Each \$311.00**



### 2-DOOR CABINETS

- (2) 16 3/4" W x 21" D x 12" H
  - Weight: 48 lbs.
- Model No. FH667**  
**Price/Each \$365.00**



### 2-DRAWER W/1-DOOR CABINETS

- (2) 15 3/8" W x 20" D x 5 5/8" H
  - (1) 16 3/4" W x 21" D x 12" H
  - Weight: 59 lbs.
- Model No. FH668**  
**Price/Each \$485.00**



### 2-DRAWER CABINETS

- (2) 15 3/8" W x 20" D x 11 5/8" H
  - Weight: 66 lbs.
- Model No. F1166**  
**Price/Each \$422.00**



### 3-DRAWER CABINETS

- (2) 15 3/8" W x 20" D x 5 5/8" H
  - (1) 15 3/8" W x 20" D x 11 5/8" H
  - Weight: 78 lbs.
- Model No. F1167**  
**Price/Each \$487.00**



### 4-DRAWER CABINETS

- (4) 15 3/8" W x 20" D x 5 5/8" H
  - Weight: 68 lbs.
- Model No. FH669**  
**Price/Each \$634.00**



### 4-DRAWER W/1-DOOR CABINETS

- (4) 15 3/8" W x 20" D x 2 5/8" H
  - (1) 16 3/4" W x 21" D x 12" H
  - Weight: 63 lbs.
- Model No. FH670**  
**Price/Each \$678.00**



### 6-DRAWER CABINETS

- (4) 15 3/8" W x 20" D x 2 5/8" H
  - (2) 15 3/8" W x 20" D x 5 5/8" H
  - Weight: 94 lbs.
- Model No. FH671**  
**Price/Each \$838.00**



### OPTIONAL PEDESTAL BASES

- (1) 4" high - 34" high with top
  - Weight: 5 lbs.
- Model No. FH672**  
**Price/Each \$49.35**



## LEG & PEDESTAL COMBINATIONS

- All-welded 14-gauge steel legs
- Knockout for standard two-outlet electrical plug
- Overall height of 34" with top
- Powder coat Kleton grey finish

Model No.	Description	Dimensions			Wt. lbs.	Price /Each
		D"	x	H"		
ML264	Single leg for use w/ 24" D top	22	x	32	14	71.50
ML265	Single leg for use w/ 30" D or 36" D top	28	x	32	15	78.40
FH672	Pedestal Base (Max 1)			4" H	5	49.35
FF920	Bench Leg Gussets (Pkg. of 2)				3	38.30

Pedestal base and bench leg gussets are required components when building all leg/pedestal combinations



We try to make it easy... look at our pre-designed layout options on pages 116 and 117.

### HOW TO ORDER

1. Choose the pedestal desired
  2. Determine the depth of the workbench
  3. Add the appropriate leg configuration
- See our selection of workbench tops on page 115.

## WORKBENCH TOPS

SELECT ONE OF THESE SIX TOPS TO CUSTOMIZE YOUR WORKBENCH.

### LAMINATED HARDWOOD TOPS SQUARE EDGE

- Lacquer finished tops for durability
- Heavy-duty solid hardwood laminations for long life
- Overall thickness: 1 3/4"
- 1/8" radius edge



Model No.	Size D" x W"	Wt. lbs.	Price /Each
FI730	24 x 48	56	259.00
FD016	24 x 60	70	269.00
FD017	24 x 72	84	359.00
FI731	24 x 84	98	489.00
FG970	24 x 96	112	499.00
FI732	24 x 120	140	749.00
FD019	30 x 48	70	299.00
FI733	30 x 60	88	339.00
FI734	30 x 72	105	399.00
FI735	30 x 84	123	589.00
FI736	30 x 96	140	599.00
FI737	30 x 120	175	799.00
FD025	36 x 48	84	349.00
FD026	36 x 60	105	399.00
FI738	36 x 72	126	489.00
FD028	36 x 84	147	669.00
FI739	36 x 96	168	679.00
FD023	36 x 120	210	929.00
FI740	48 x 48	112	699.00
FG977	48 x 60	140	799.00
FG978	48 x 72	168	949.00
FG979	48 x 84	196	1199.00
FG980	48 x 96	224	1249.00
FG982	48 x 120	280	1399.00

**Note:** Tops over 36" W are shipped in two pieces of hardwood, hardware is included.

### PLASTIC LAMINATE TOPS

- Light-duty top with smooth white plastic laminate face covering 45-lb. density particle board
- Overall thickness: 1 5/8"
- Colour: White



Model No.	Size D" x W"	Wt. lbs.	Price /Each
FD008	24 x 48	65	214.00
FD009	24 x 60	72	234.00
FH771	30 x 48	72	234.00
FD011	30 x 60	90	256.00
FD012	30 x 72	108	309.00
FH772	30 x 84	126	429.00
FH773	30 x 96	144	429.00
FH774	36 x 48	86	294.00
FD013	36 x 60	108	319.00
FD014	36 x 72	130	383.00
FH776	36 x 84	151	448.00
FH777	36 x 96	173	448.00

### LAMINATED HARDWOOD TOPS BULLNOSE EDGE

- Lacquer finished tops for durability
- Heavy-duty solid hardwood laminations for long life
- Overall thickness: 1 3/4"
- 3/8" radius edge



Model No.	Size D" x W"	Wt. lbs.	Price /Each
FH739	24 x 48	56	289.00
FH740	24 x 60	70	299.00
FH741	24 x 72	84	389.00
FH742	24 x 84	98	509.00
FH743	24 x 96	112	519.00
FH744	24 x 120	140	769.00
FH745	30 x 48	70	339.00
FH746	30 x 60	88	409.00
FH747	30 x 72	105	419.00
FH748	30 x 84	123	609.00
FH749	30 x 96	140	629.00
FH750	30 x 120	175	839.00
FH751	36 x 48	84	379.00
FH752	36 x 60	105	439.00
FH753	36 x 72	126	529.00
FH754	36 x 84	147	709.00
FH755	36 x 96	168	699.00
FH756	36 x 120	210	969.00
FH757	48 x 48	112	719.00
FH758	48 x 60	140	819.00
FH759	48 x 72	168	979.00
FH760	48 x 84	196	1229.00
FH761	48 x 96	224	1279.00
FH762	48 x 120	280	1429.00

**Note:** Tops over 36" W are shipped in two pieces of hardwood, hardware is included.

### STEEL WOOD-FILLED TOPS

- Heavy-duty 14-gauge steel with formed edges
- Reinforced with wood core for sound reduction and added strength
- Overall thickness: 1 3/4"
- Colour: Powder coat Kleton grey

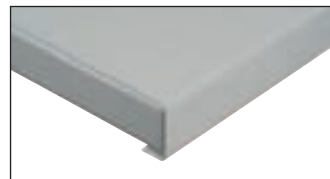

Model No.	Size D" x W"	Wt. lbs.	Price /Each
FD030	24 x 48	59	229.00
FD031	24 x 60	74	249.00
FH871	30 x 48	74	269.00
FD033	30 x 60	92	279.00
FD034	30 x 72	110	329.00
FH872	30 x 84	129	459.00
FH873	30 x 96	147	479.00
FH874	36 x 48	89	309.00
FD035	36 x 60	110	329.00
FD036	36 x 72	132	399.00
FH875	36 x 84	154	479.00
FH876	36 x 96	176	499.00



### SHOP TOPS

- Great top for medium-duty applications
- 3/8" double sealed resin boards laminated over 1 1/8" MDF core
- Overall thickness: 1 3/4"



Model No.	Size D" x W"	Wt. lbs.	Price /Each
FD001	24 x 48	60	169.00
FD002	24 x 60	75	189.00
FH764	30 x 48	75	189.00
FD004	30 x 60	94	189.00
FD005	30 x 72	113	244.00
FH765	30 x 84	131	339.00
FH766	30 x 96	150	339.00
FH767	36 x 48	90	234.00
FD006	36 x 60	113	253.00
FD007	36 x 72	135	279.00
FH768	36 x 84	158	425.00
FH769	36 x 96	180	425.00

### 304 STAINLESS STEEL WOOD-FILLED TOPS

- Heavy-duty 14-gauge stainless steel with a number 4 finish and formed edges
- Reinforced with wood core for sound reduction and added strength
- Overall thickness: 1 3/4"

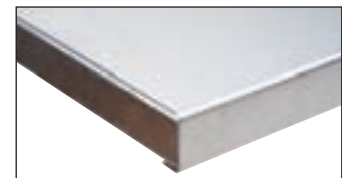

Model No.	Size D" x W"	Wt. lbs.	Price /Each
FI268*	24 x 48	59	531.00
FI269*	24 x 60	74	577.00
FI270*	30 x 48	74	619.00
FI271*	30 x 60	92	672.00
FI272*	30 x 72	110	730.00
FI273*	30 x 84	129	892.00
FI274*	30 x 96	147	970.00
FI275*	36 x 48	89	663.00
FI276*	36 x 60	110	716.00
FI277*	36 x 72	132	795.00
FI278*	36 x 84	154	970.00
FI279*	36 x 96	176	1037.00

\* Stainless Steel finish may vary

# WORKBENCHES

## PRE-DESIGNED WORKBENCHES

Also available in 304 stainless steel wood filled top

SELECT FROM ONE OF OUR PRE-DESIGNED LAYOUT OPTIONS. 34" OVERALL HEIGHT, CAPACITY 2500 LBS. EVENLY DISTRIBUTED.

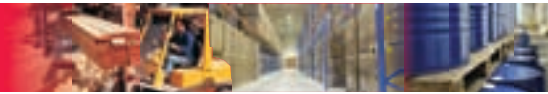

Model No.	Size D" x W"	Wt. lbs.	Price /Each
FF672	36 x 72	164	435.00
FF671	36 x 60	156	399.00
FF670	30 x 72	166	399.00
FF669	30 x 60	146	374.00
FF667	24 x 60	110	366.00

### STEEL - WOOD FILL

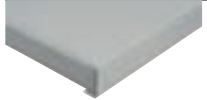

### LAMINATED WOOD - BULLNOSE EDGE

Model No.	Size D" x W"	Wt. lbs.	Price /Each
FF658	36 x 72	171	679.00
FF657	36 x 60	149	659.00
FF656	30 x 72	150	629.00
FF655	30 x 60	130	559.00
FF653	24 x 60	106	499.00

### SHOP TOPS

Model No.	Size D" x W"	Wt. lbs.	Price /Each
FF679	36 x 72	171	476.00
FH877	36 x 60	157	423.00
FF677	30 x 72	150	412.00
FF676	30 x 60	133	368.00
FH878	24 x 60	111	346.00

### PLASTIC LAMINATE

Model No.	Size D" x W"	Wt. lbs.	Price /Each
FF665	36 x 72	171	562.00
FH879	36 x 60	152	491.00
FF663	30 x 72	150	480.00
FF662	30 x 60	133	425.00
FH880	24 x 60	108	399.00



Model No.	Size D" x W"	Wt. lbs.	Price /Each
FG109	36 x 72	209	864.00
FG108	36 x 60	201	843.00
FG107	30 x 72	211	843.00
FG106	30 x 60	191	815.00
FG104	24 x 60	161	799.00

### LAMINATED WOOD - BULLNOSE EDGE

Model No.	Size D" x W"	Wt. lbs.	Price /Each
FG095	36 x 72	216	1149.00
FG094	36 x 60	194	1113.00
FG093	30 x 72	195	1067.00
FG092	30 x 60	175	999.00
FG090	24 x 60	158	923.00

### SHOP TOPS

Model No.	Size D" x W"	Wt. lbs.	Price /Each
FG116	36 x 72	216	859.00
FH889	36 x 60	202	830.00
FG114	30 x 72	195	819.00
FG113	30 x 60	178	758.00
FH890	24 x 60	163	749.00

### PLASTIC LAMINATE

Model No.	Size D" x W"	Wt. lbs.	Price /Each
FG102	36 x 72	216	968.00
FH891	36 x 60	197	899.00
FG100	30 x 72	195	887.00
FG099	30 x 60	178	832.00
FH892	24 x 60	161	801.00



Model No.	Size D" x W"	Wt. lbs.	Price /Each
FF707	36 x 72	201	566.00
FF706	36 x 60	188	525.00
FF703	30 x 72	203	529.00
FF702	30 x 60	178	500.00
FF700	24 x 60	142	491.00

### STEEL - WOOD FILL

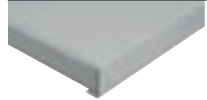

### LAMINATED WOOD - BULLNOSE EDGE

Model No.	Size D" x W"	Wt. lbs.	Price /Each
FF691	36 x 72	208	829.00
FF690	36 x 60	181	799.00
FF689	30 x 72	187	759.00
FF688	30 x 60	162	689.00
FF686	24 x 60	138	629.00

### SHOP TOPS

Model No.	Size D" x W"	Wt. lbs.	Price /Each
FF715	36 x 72	208	607.00
FH881	36 x 60	189	548.00
FF713	30 x 72	187	543.00
FF712	30 x 60	165	493.00
FH882	24 x 60	143	472.00

### PLASTIC LAMINATE

Model No.	Size D" x W"	Wt. lbs.	Price /Each
FF698	36 x 72	208	692.00
FH883	36 x 60	184	617.00
FF696	30 x 72	187	611.00
FF695	30 x 60	165	550.00
FH884	24 x 60	140	525.00



Model No.	Size D" x W"	Wt. lbs.	Price /Each
FG277	36 x 72	208	1059.00
FG276	36 x 60	200	1021.00
FG275	30 x 72	210	1021.00
FG274	30 x 60	190	998.00
FG273	24 x 60	160	984.00

### LAMINATED WOOD - BULLNOSE EDGE

Model No.	Size D" x W"	Wt. lbs.	Price /Each
FG269	36 x 72	215	1199.00
FG268	36 x 60	193	1149.00
FG267	30 x 72	194	1149.00
FG266	30 x 60	174	999.00
FG265	24 x 60	156	979.00

### SHOP TOPS

Model No.	Size D" x W"	Wt. lbs.	Price /Each
FG280	36 x 72	215	1093.00
FH893	36 x 60	201	1040.00
FG279	30 x 72	194	1029.00
FG278	30 x 60	177	986.00
FH894	24 x 60	165	961.00

### PLASTIC LAMINATE

Model No.	Size D" x W"	Wt. lbs.	Price /Each
FG272	36 x 72	215	1179.00
FH895	36 x 60	198	1112.00
FG271	30 x 72	194	1097.00
FG270	30 x 60	177	1042.00
FH896	24 x 60	158	1013.00



Model No.	Size D" x W"	Wt. lbs.	Price /Each
FG293	36 x 72	228	725.00
FG292	36 x 60	215	679.00
FG291	30 x 72	230	689.00
FG290	30 x 60	205	659.00
FG289	24 x 60	169	649.00

### STEEL - WOOD FILL



### LAMINATED WOOD - BULLNOSE EDGE

Model No.	Size D" x W"	Wt. lbs.	Price /Each
FG285	36 x 72	235	949.00
FG284	36 x 60	208	929.00
FG283	30 x 72	214	889.00
FG282	30 x 60	189	829.00
FG281	24 x 60	165	759.00

### SHOP TOPS

Model No.	Size D" x W"	Wt. lbs.	Price /Each
FG296	36 x 72	235	779.00
FH885	36 x 60	216	719.00
FG295	30 x 72	214	719.00
FG294	30 x 60	192	669.00
FH886	24 x 60	170	649.00

### PLASTIC LAMINATE

Model No.	Size D" x W"	Wt. lbs.	Price /Each
FG288	36 x 72	235	869.00
FH887	36 x 60	211	799.00
FG287	30 x 72	214	789.00
FG286	30 x 60	192	729.00
FH888	24 x 60	167	699.00



Model No.	Size D" x W"	Wt. lbs.	Price /Each
FG640	36 x 72	213	1253.00
FG641	36 x 60	205	1216.00
FG642	30 x 72	215	1216.00
FG444	30 x 60	195	1124.00
FG443	24 x 60	165	1111.00

### LAMINATED WOOD - BULLNOSE EDGE

Model No.	Size D" x W"	Wt. lbs.	Price /Each
FG635	36 x 72	220	1299.00
FG636	36 x 60	198	1249.00
FG637	30 x 72	199	1199.00
FG638	30 x 60	179	1199.00
FG639	24 x 60	162	1099.00

### SHOP TOPS

Model No.	Size D" x W"	Wt. lbs.	Price /Each
FG645	36 x 72	220	1289.00
FH897	36 x 60	205	1235.00
FG646	30 x 72	199	1223.00
FG647	30 x 60	182	1180.00
FH898	24 x 60	167	1156.00

### PLASTIC LAMINATE

Model No.	Size D" x W"	Wt. lbs.	Price /Each
FG648	36 x 72	220	1374.00
FH899	36 x 60	202	1304.00
FG649	30 x 72	199	1292.00
FG650	30 x 60	182	1237.00
FH900	24 x 60	164	1215.00

If you need specific sizes or requirements not available on this page, see pages 112 to 113 to customize your own workbench or call us today with your specs!

Refer to pages 118 and 119 for your above-workbench workstation



## PRE-DESIGNED WORKBENCHES

Also available in 304 stainless steel wood filled top

SELECT FROM ONE OF OUR PRE-DESIGNED LAYOUT OPTIONS. 34" OVERALL HEIGHT, CAPACITY 2500 LBS. EVENLY DISTRIBUTED.



Model No.	Size D" x W"	Wt. lbs.	Price /Each
FG137	36 x 72	304	1134.00
FG136	36 x 60	296	1114.00
FG135	30 x 72	306	1114.00
FG134	30 x 60	286	1086.00
FG132	24 x 60	257	1078.00

### LAMINATED WOOD - BULLNOSE EDGE

FG123	36 x 72	311	1399.00
FG122	36 x 60	289	1384.00
FG121	30 x 72	290	1338.00
FG120	30 x 60	270	1269.00
FG118	24 x 60	254	1199.00

### SHOP TOPS

FG144	36 x 72	311	1129.00
FH901	36 x 60	297	1100.00
FG142	30 x 72	290	1090.00
FG141	30 x 60	273	1029.00
FH902	24 x 60	258	1028.00

### PLASTIC LAMINATE

FG130	36 x 72	311	1238.00
FH903	36 x 60	292	1170.00
FG128	30 x 72	290	1158.00
FG127	30 x 60	273	1103.00
FH904	24 x 60	256	1079.00



Model No.	Size D" x W"	Wt. lbs.	Price /Each
FG245	36 x 72	263	1172.00
FG244	36 x 60	255	1149.00
FG243	30 x 72	265	1149.00
FG242	30 x 60	245	1123.00
FG241	24 x 60	246	1116.00

### LAMINATED WOOD - BULLNOSE EDGE

FG237	36 x 72	270	1439.00
FG236	36 x 60	248	1420.00
FG235	30 x 72	249	1375.00
FG234	30 x 60	229	1309.00
FG233	24 x 60	213	1238.00

### SHOP TOPS

FG248	36 x 72	270	1167.00
FH905	36 x 60	256	1137.00
FG247	30 x 72	249	1127.00
FG246	30 x 60	232	1066.00
FH906	24 x 60	218	1066.00

### PLASTIC LAMINATE

FG240	36 x 72	270	1276.00
FH907	36 x 60	251	1208.00
FG239	30 x 72	249	1195.00
FG238	30 x 60	232	1140.00
FH908	24 x 60	215	1117.00



Model No.	Size D" x W"	Wt. lbs.	Price /Each
FG624	36 x 72	266	1790.00
FG625	36 x 60	258	1752.00
FG626	30 x 72	268	1752.00
FG627	30 x 60	248	1730.00
FG628	24 x 60	219	1723.00

### LAMINATED WOOD - BULLNOSE EDGE

FG619	36 x 72	273	1799.00
FG620	36 x 60	251	1749.00
FG621	30 x 72	252	1699.00
FG622	30 x 60	232	1699.00
FG623	24 x 60	216	1599.00

### SHOP TOPS

FG629	36 x 72	271	1825.00
FH909	36 x 60	259	1772.00
FG630	30 x 72	252	1760.00
FG631	30 x 60	235	1718.00
FH910	24 x 60	221	1698.00

### PLASTIC LAMINATE

FG632	36 x 72	273	1910.00
FH911	36 x 60	254	1842.00
FG633	30 x 72	252	1829.00
FG634	30 x 60	235	1775.00
FH912	24 x 60	218	1751.00



Model No.	Size D" x W"	Wt. lbs.	Price /Each
FG464	36 x 72	247	1399.00
FG465	36 x 60	239	1384.00
FG466	30 x 72	249	1384.00
FG467	30 x 60	229	1355.00
FG468	24 x 60	200	1348.00

### LAMINATED WOOD - BULLNOSE EDGE

FG459	36 x 72	254	1445.00
FG460	36 x 60	232	1654.00
FG461	30 x 72	233	1607.00
FG462	30 x 60	213	1539.00
FG463	24 x 60	197	1470.00

### SHOP TOPS

FG469	36 x 72	254	1399.00
FH913	36 x 60	240	1370.00
FG470	30 x 72	233	1359.00
FG471	30 x 60	216	1298.00
FH914	24 x 60	202	1298.00

### PLASTIC LAMINATE

FG472	36 x 72	254	1509.00
FH915	36 x 60	235	1440.00
FG473	30 x 72	233	1427.00
FG474	30 x 60	216	1373.00
FH916	24 x 60	199	1349.00



Model No.	Size D" x W"	Wt. lbs.	Price /Each
FG229	36 x 72	261	1595.00
FG228	36 x 60	253	1557.00
FG227	30 x 72	263	1557.00
FG226	30 x 60	243	1535.00
FG225	24 x 60	214	1528.00

### LAMINATED WOOD - BULLNOSE EDGE

FG221	36 x 72	268	1599.00
FG220	36 x 60	246	1549.00
FG219	30 x 72	247	1499.00
FG218	30 x 60	227	1449.00
FG217	24 x 60	211	1399.00

### SHOP TOPS

FG232	36 x 72	268	1631.00
FH917	36 x 60	254	1577.00
FG231	30 x 72	247	1566.00
FG230	30 x 60	230	1522.00
FH918	24 x 60	216	1499.00

### PLASTIC LAMINATE

FG224	36 x 72	267	1716.00
FH919	36 x 60	249	1646.00
FG223	30 x 72	247	1634.00
FG222	30 x 60	230	1579.00
FH920	24 x 60	213	1556.00



Model No.	Size D" x W"	Wt. lbs.	Price /Each
FG415	36 x 72	271	1985.00
FG414	36 x 60	263	1947.00
FG413	30 x 72	273	1947.00
FG412	30 x 60	253	1924.00
FG411	24 x 60	224	1917.00

### LAMINATED WOOD - BULLNOSE EDGE

FG420	36 x 72	278	1999.00
FG419	36 x 60	256	1949.00
FG418	30 x 72	257	1899.00
FG417	30 x 60	237	1849.00
FG416	24 x 60	221	1799.00

### SHOP TOPS

FG423	36 x 72	278	2020.00
FH921	36 x 60	264	1966.00
FG422	30 x 72	257	1954.00
FG421	30 x 60	240	1911.00
FH922	24 x 60	226	1892.00

### PLASTIC LAMINATE

FG426	36 x 72	278	2104.00
FH923	36 x 60	259	2036.00
FG425	30 x 72	257	2023.00
FG424	30 x 60	240	1968.00
FH924	24 x 60	223	1946.00

If you need specific sizes or requirements not available on this page, see pages 112 to 113 to customize your own workbench or call us today with your specs!

Refer to pages 118 and 119 for your above-workbench workstation

# WORKBENCHES

## ERGONOMIC WORKSTATIONS

- Highly functional and flexible system of above-work surface accessories and modular components
- Ergonomically designed, delivering easy accessibility with no stretch or strain
- Modular design allows for easy reconfiguration

### Workstation benefits include:

- Greater productivity and efficiency
- Reduced strain and increased ergonomic ease
- Equipped to exactly suit your needs
- Properly illuminated work areas

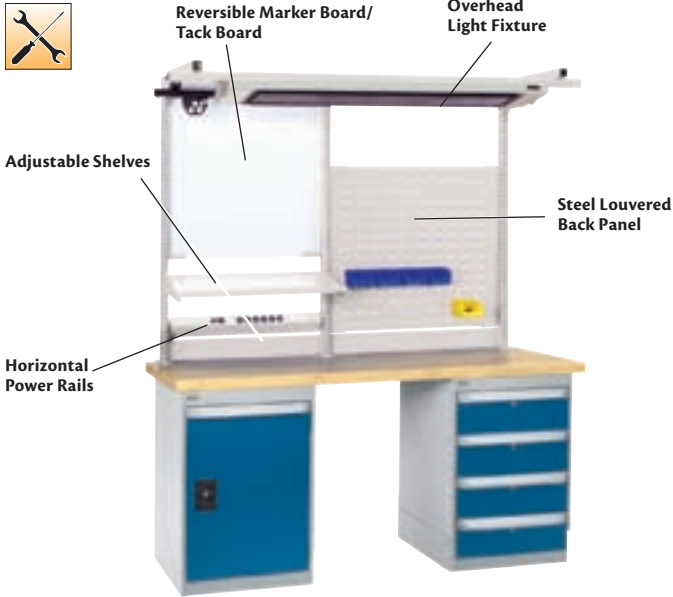

### TO PICK THE RIGHT FRAME FOR YOUR NEEDS YOU MUST DETERMINE THE FOLLOWING MEASUREMENTS:

**Section Width (A):** Is measured from the centre of one upright to the other.  
**Overall Width (B):** Is measured from the outside of one foot plate to the other.  
 Then determine if you require a single frame or double frame unit.

### SURFACE MOUNT FRAMES

- Frames are made from a heavy gauge steel and are notched front and back at 1" increments
- Foot plate is 2 3/4" x 4"

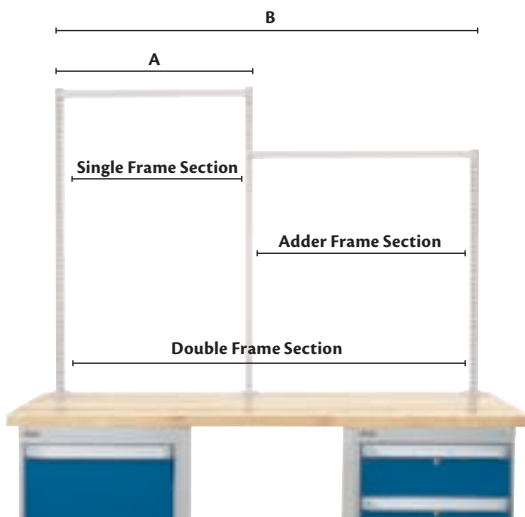

### SINGLE FRAME SECTIONS

Model No.	Height"	Section Width" (A)	Min Work Surface Width" Required	Price /Each
FI368	30	24	30	190.00
FI370	30	30	36	199.00
FH992	30	36	42	199.00
FI372	30	42	48	199.00
FH993	30	48	54	211.00
FI374	30	60	66	211.00
FI369	48	24	30	199.00
FI371	48	30	36	211.00
FH994	48	36	42	211.00
FI373	48	42	48	211.00
FH995	48	48	54	222.00
FI375	48	60	66	222.00

### ADDER FRAME SECTION

Model No.	Height"	Section Width" (A)	Min Work Surface Width" Required	Price /Each
FI376	30	24	54	127.00
FI378	30	30	60	137.00
FI380	30	36	66	137.00
FI382	30	42	72	137.00
FI384	30	48	78	148.00
FI386	30	60	90	148.00
FI377	48	24	54	137.00
FI379	48	30	60	148.00
FI381	48	36	66	148.00
FI383	48	42	72	148.00
FI385	48	48	78	158.00
FI387	48	60	90	158.00

### DOUBLE FRAME SECTIONS

Model No.	Height"	Section Width"	Min Work Surface Width" Required	Price /Each
FI747	30	24 + 24	54	342.00
FI749	30	24 + 30	60	353.00
FL525	30	24 + 36	66	327.00
FL526	30	24 + 42	72	327.00
FL527	30	24 + 48	78	338.00
FL528	30	24 + 60	90	338.00
FL529	30	30 + 30	66	338.00
FL530	30	30 + 36	72	338.00
FL531	30	30 + 42	78	338.00
FL532	30	30 + 48	84	349.00
FL533	30	30 + 60	96	349.00
FL534	30	36 + 36	78	338.00
FL535	30	36 + 42	84	338.00
FL536	30	36 + 48	90	349.00
FL537	30	36 + 60	102	349.00
FL538	30	42 + 42	90	338.00
FL539	30	42 + 48	96	349.00
FL540	30	42 + 60	108	349.00
FL541	30	48 + 48	102	359.00
FL542	30	48 + 60	114	359.00
FL543	30	60 + 60	126	359.00
FI748	48	24 + 24	54	365.00
FI750	48	24 + 30	60	376.00
FL544	48	24 + 36	66	349.00
FL545	48	24 + 42	72	349.00
FL546	48	24 + 48	78	359.00
FL547	48	24 + 60	90	359.00
FL548	48	30 + 30	66	296.00
FL549	48	30 + 36	72	296.00
FL550	48	30 + 42	78	296.00
FL551	48	30 + 48	84	306.00
FL552	48	30 + 60	96	306.00
FL553	48	36 + 36	78	296.00
FL554	48	36 + 42	84	296.00
FL555	48	36 + 48	90	306.00
FL556	48	36 + 60	102	306.00
FL557	48	42 + 42	90	296.00
FL558	48	42 + 48	96	306.00
FL559	48	42 + 60	108	306.00
FL560	48	48 + 48	102	316.00
FL561	48	48 + 60	114	316.00
FL562	48	60 + 60	126	316.00

## NEXUS SYSTEM WORKBENCH ACCESSORIES

### OVERHEAD CABINETS

- Protect, secure above-work-surface storage of large, bulky items



Model No.	Overall Dimensions W" x D" x H"	Price /Each
FI364	24 x 15 x 16	590.00
FI365	30 x 15 x 16	644.00
FI366	36 x 15 x 16	728.00
FI367	48 x 15 x 16	892.00

### REPLACEMENT PARTS

FI362	Support Brackets for 16" Overall Height	62.20
-------	---	-------

### OVERHEAD LIGHT FIXTURES

- Tilts up or down 10°
- Kit includes a switch, 8' grounded electrical cord, support track, standard acrylic diffuser and T8 bulbs
- Support bracket sold separately



Model No.	Use with Frame Overall Width"	Price /Each
FI019	48	483.00
FI020	60	519.00

### SUPPORT BRACKETS

Model No.	Use with Frame Overall Depth"	Price /Each
FI327	Less than 30	80.20
FI328	Greater than or equal to 30	97.00

### HORIZONTAL POWER BOARDS

- 15 Amps with six plugs
- Pivots on axis providing full horizontal adjustability



Model No.	Overall Width"	Price /Each
FI022	24	249.00
FI023	30	249.00
FI024	36	259.00
FI025	48	270.00

### VERTICAL POWER BOARDS

- 15 Amps with six outlets
- Mounts vertically to front and back of upright
- Features a lighted on/off switch, 6' cord with grounded plug and circuit breaker
- Bracket and hardware included

Model No. FI021  
Price/Each \$181.00



### PLASTIC BOX RAILS

- Easily adjustable for ergonomic access
- Can be mounted either parallel or at a 15° angle to the workstation
- Suitable to use with bins that have a rear lip
- Plastic bins not included



Model No.	Overall Width"	Price /Each
FI030	24	80.20
FI031	30	80.20
FI032	36	90.80
FI033	48	101.00

### ADJUSTABLE SHELVES

- Adjustable, heavy gauge steel shelves can be mounted parallel to the work surface or at a 15° angle for easy ergonomic access
- 100-lb. capacity evenly distributed



Model No.	Overall Dimensions W" x D"	Price /Each
FI001	24 x 12	116.00
FI002	30 x 12	132.00
FI003	36 x 12	132.00
FI004	48 x 12	144.00
FI005	24 x 15	132.00
FI006	30 x 15	144.00
FI007	36 x 15	144.00
FI008	48 x 15	157.00
FI009	24 x 18	182.00
FI010	30 x 18	194.00
FI011	36 x 18	194.00
FI012	48 x 18	207.00

### SHELF DIVIDERS

- Shelf dividers fit over the edge of the shelf when it is mounted parallel to the work surface



Model No.	Overall Dimensions D" x H"	Price /Each
FI013	12 x 4	21.10
FI014	12 x 6	25.90
FI015	12 x 8	30.60
FI016	15 x 4	25.90
FI017	15 x 6	30.60
FI018	15 x 8	35.20

### STEEL LOUVERED BACK PANELS

- Designed to accommodate industry standard plastic bins that featured louvered edge or lip



Model No.	Overall Dim. W" x H"	Price /Each	Model No.	Overall Dim. W" x H"	Price /Each
FI034	24 x 18	144.00	FI038	24 x 30	158.00
FI035	30 x 18	144.00	FI039	30 x 30	158.00
FI036	36 x 18	154.00	FI040	36 x 30	169.00
FI037	48 x 18	165.00	FI041	48 x 30	179.00

### REVERSIBLE MARKERBOARDS/TACKBOARDS

- Two-sided reversible board
- Features white magnetic marker board on one side and grey fabric panel on the other



Model No.	Overall Dimensions W" x H"	Price /Each
FI050	24 x 30	285.00
FI051	30 x 30	285.00
FI052	36 x 30	412.00
FI053	48 x 30	549.00

### STEEL PEGBOARD PANELS

- Accepts all standard pegging devices
- Holes are 1/4" in diameter



Model No.	Overall Dim. W" x H"	Price /Each	Model No.	Overall Dim. W" x H"	Price /Each
FI042	24 x 18	144.00	FI046	24 x 30	158.00
FI043	30 x 18	144.00	FI047	30 x 30	158.00
FI044	36 x 18	154.00	FI048	36 x 30	169.00
FI045	48 x 18	165.00	FI049	48 x 30	179.00

Other sizes available upon request



## EXTRA HEAVY-DUTY WORKBENCHES

### ALL-WELDED BENCHES

- All-welded construction features a wood-filled 3/16" steel top with 11 gauge steel legs and stringers
- Standard bolt-down footplates
- Mobile units come w/6" polyurethane casters, two swivel w/brakes, and two rigid
- Overall height is 34"
- Capacity is based on evenly distributed weight
- Durable Kleton blue enamel finish



REFER TO PAGES  
118 AND 119 FOR YOUR  
ABOVE-WORKBENCH  
WORKSTATION

### PEDESTAL BENCHES

- Designed for workshop applications
- Feature 1 3/4" thick solid laminated hardwood top, mounted on two all-welded pedestals with two shelves each
- Pedestals are 18" W x 24" D x 32" H
- Overall height: 34"
- Capacity is based on evenly distributed weight
- Durable Kleton blue enamel finish
- Shipped knocked down

KLETON



Model No.	Style	Dimensions			Cap. lbs.	Wt. lbs.	Price /Each
		W"	x	D"	x	H"	
FF494	Static	72	x	30	x	34	5000 290 949.00
FF495	Static	72	x	36	x	34	5000 360 999.00
FH465	Mobile	72	x	30	x	34	3500 290 1120.00
FH466	Mobile	72	x	36	x	34	3500 360 1186.00

Model No.	Dimensions	Cap. lbs.	Wt. lbs.	Price /Each
	W" x D" x H"			
FF120	60 x 30 x 34	2500	158	839.00
FF121	72 x 30 x 34	2500	175	899.00
FF122	84 x 30 x 34	2500	192	1199.00
FF119	120 x 30 x 34	2500	245	1260.00

## HEAVY-DUTY STAINLESS STEEL WORKBENCHES

- Work surface is constructed of 14-gauge stainless steel with an 11-gauge support structure
- 1 5/8" diameter posts with tapered sleeves and corners
- Standard units are stationary with leveling foot on each post
- 30" models can be fitted with 5" polyurethane swivel casters, two with wheel brake
- Capacity is based on evenly distributed weight
- Shipped knocked down



FI388



FI391

Model No.	Description	Overall Dimensions			Cap. lbs.	Wt. lbs.	Price /Each
		W" x D" x H"					
FI388	3-Sided Frame	60 x 30 x 34		625	104	1649.00	
FI389	3-Sided Frame	72 x 30 x 34		750	121	1799.00	
FI390	3-Sided Frame	96 x 30 x 34		1000	150	2149.00	
FI391	H-Frame	60 x 30 x 34		625	104	1649.00	
FI392	H-Frame	72 x 30 x 34		750	120	1799.00	
FI393	H-Frame	96 x 30 x 34		1000	150	2149.00	

### DRAWERS

FI412	Economy Drawer	14 x 28 x 5 3/4	7	146.00
FI413	Deluxe Drawer	24 x 25 3/4 x 7 1/2	31	959.00

\* Models are also available in 36" and 44" depths

## ECONOMY GRADE OPEN WORKBENCHES

- Meet any strength requirement for light manufacturing, assembly operations, maintenance service, etc.
- Heavy gauge adjustable legs from 29" to 34"
- Front and back electrical knockouts
- 12" deep lower shelf
- Choose between 1" presswood top, or plastic top (1 1/4" grey laminated plastic surface) widely used in electronics, laboratories, and institutions
- Optional drawer, model FH271 can be added to all models
- Capacity: 200 lbs./sq. ft., evenly distributed
- Shipped knocked down



FH214

Model No.	Description	Capacity lbs.	Dimensions	Wt. lbs.	Price /Each
			W" x D"		
FH213	1" Presswood Top	1600	48 x 24	70	205.00
FH214	1" Presswood Top	2000	60 x 24	76	249.00
FH215	1" Presswood Top	2400	72 x 24	82	309.00
FH216	1" Presswood Top	2500	60 x 30	83	345.00
FH217	1" Presswood Top	3000	72 x 30	92	385.00
FF649	1 1/4" Plastic Top	1600	48 x 24	77	345.00
FF650	1 1/4" Plastic Top	2000	60 x 24	83	419.00
FF651	1 1/4" Plastic Top	3000	72 x 30	122	555.00
FH271	Optional Drawer Only		18 x 12	12	53.50

## HEAVY-DUTY MACHINE STANDS

- Designed for use as machinery stand or work table when full-sized workbench is not necessary
- 14" shelf clearance
- All-welded construction
- 14-gauge steel lip-down shelves, with bolt-down footplates on 3/16" x 1 1/2" angle leg
- Capacity is based on evenly distributed weight
- Durable Kleton blue enamel finish



KLETON



FH269

Model No.	Dimensions	Cap. lbs.	Wt. lbs.	Price /Each
	W" x D" x H"			
FH268	30 x 18 x 32	1200	60	202.00
FH269	36 x 24 x 32	1200	70	224.00
FH270	48 x 24 x 32	1200	85	269.00



## VARI-TUFF™ ERGONOMIC WORKBENCHES

- Knocked-down, folding leg style
- Assembles in minutes
- Two brace supports and hardware supplied with each leg
- Eliminates stringers
- One package contains entire bench
- Choice of steel tops or tempered hardwood over steel (THS)
- Adjustable height from 28" to 42"
- Legs made of 13 gauge steel
- Channel formed on all four sides
- All four corners are welded and ground smooth
- 120" W unit comes with three sets of legs, all others come with two
- Capacity: 2000 lbs. evenly distributed
- Grey finish



FG750



FG753

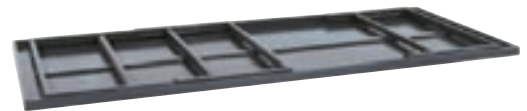

Width"	Depth"	Steel Top Model No.	Price /Each	THS Top Model No.	Price /Each
84	28	FG746	771.00	FG755	921.00
84	34	FG747	836.00	FG756	1127.00
84	48	FG748	1010.00	FG757	1191.00
96	28	FG749	827.00	FG758	1093.00
96	34	FG750	876.00	FG759	1146.00
120	28	FG752	1048.00	FG761	1339.00
120	34	FG753	1117.00	FG762	1412.00
120	48	FG754	1285.00	FG763	1535.00

## 72" LOUVERED BENCH RACKS

- All-welded louvered bench rack
- Provides tool and storage for assembly or repair operations when combined with plastic parts bin
- Designed to be permanently installed on a 72" wide workbench
- Constructed of 1 1/4" square tube frame
- Capacity is based on evenly distributed weight
- Durable Kleton blue enamel finish



CB176



Workbench not included

### RACKS ONLY

Model No.	Description	W"	x	D"	x	H"	Wt. lbs.	Price /Each
CB364	Bolt-on bench rack	72	x	15	x	40	95	477.00

### RACK & BINS COMBINATIONS

Model No.		Cabinet Size			Overall Bin Dimensions	Bin Qty.	Capacity lbs.	Price /Each
Red	Blue	Yellow	Green	Stone				
CB173	CB172	CB174	CF365	CF366	7 3/8" x 4 1/8" x 3"	144	1440	771.00
CB176	CB175	CB177	CF367	CF368	10 7/8" x 5 1/2" x 5"	72	2160	839.00
CB185	CB184	CB186	CF369	CF370	14 3/8" x 8 1/4" x 7"	36	2160	820.00

## MAXI-BENCH WORKSTATIONS

- Roll your workstation to your work area
- Sturdy 30" x 60" steel wood-filled top and all-welded 14-gauge frame
- Includes: 42" H peg board panel, double drawers, swivel-out stool, lower shelf, end stops
- Mobile units come with 5" nylon non-marking casters, two rigid and two swivel with brakes
- Models FF068 and FF071 include fluorescent lamp, 25' incandescent drop light, and 4-outlet power bar
- Capacity: 1200 lbs. evenly distributed
- Durable Kleton blue enamel finish

Model No.	Description	Overall Height"	Wt. lbs.	Price /Each
FF068	Mobile, complete	76	435	2173.00
FF069	Mobile, no electrical	76	415	1848.00
FF071	Static, Complete	70	425	2165.00
FF072	Static, no electrical	70	405	1869.00



FF068



# WORKBENCHES

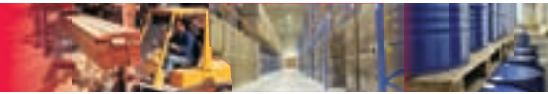

## BUILD YOUR OWN CABINET WORKBENCH

- Versatile cabinet workbench suited for any industrial application that requires work surface and secure tool and parts storage
- Steel-wood fill tops available in grey or blue
- Capacity: 3000 lbs. evenly distributed
- Durable Kleton blue enamel finish
- Shipped knocked down

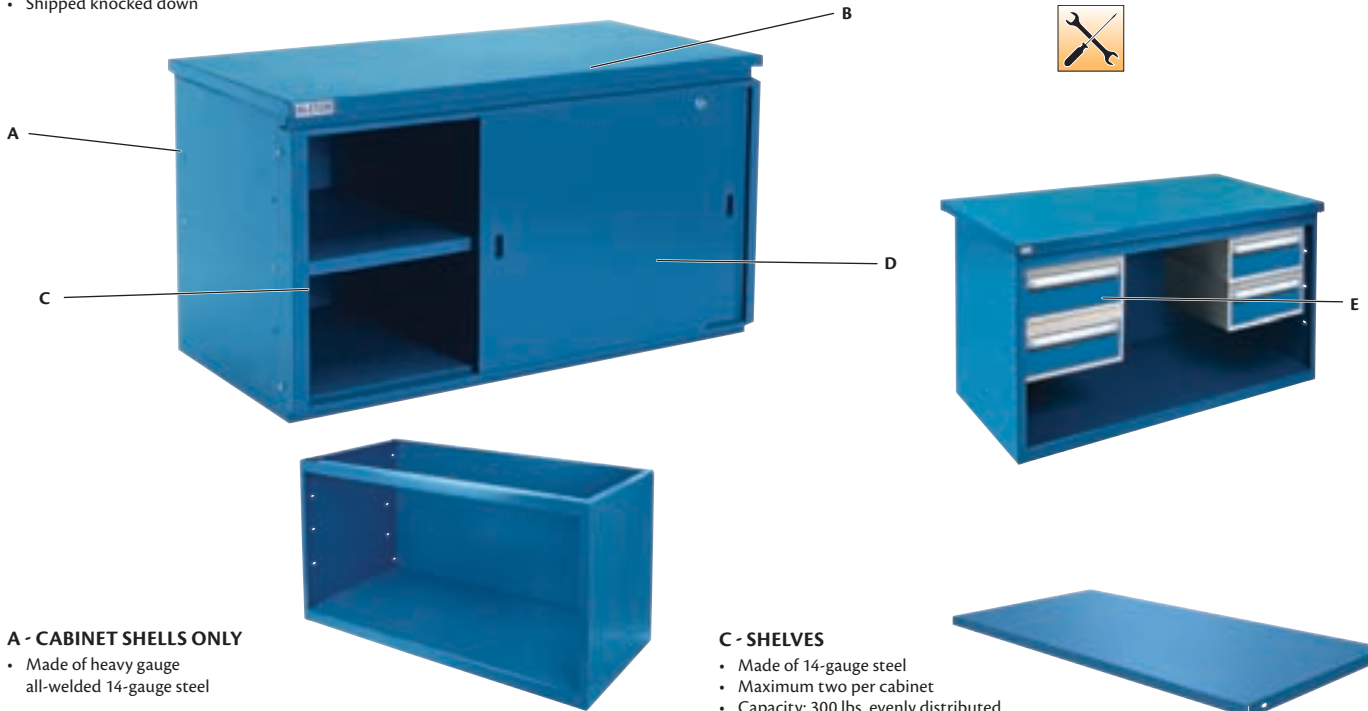

### A - CABINET SHELLS ONLY

- Made of heavy gauge all-welded 14-gauge steel

Model No.	Dimensions				Wt. lbs.	Price /Each	
	L"	x	W"	x			H"
FH165	28	x	59	x	32	105	515.00

### C - SHELVES

- Made of 14-gauge steel
- Maximum two per cabinet
- Capacity: 300 lbs. evenly distributed

Model No.	Dimensions			Wt. lbs.	Price /Each
	L"	x	W"		
FH164	27 3/4	x	58 3/4	15	165.00

### B - TOPS

- Our complete list of tops can be found on page 115

	Model No.		Size"	Price /Each
	Grey Tops	Blue Tops		
<b>STEEL - WOOD FILL</b>				
	FD033	FH183	30 x 60	279.00
	FD034	FH184	30 x 72	329.00
	FD035	FH185	36 x 60	329.00
	FD036	FH186	36 x 72	399.00
<b>LAMINATED WOOD - BULLNOSE EDGE (3/8" RADIUS)</b>				
	FH746	-	30 x 60	409.00
	FH747	-	30 x 72	419.00
	FH752	-	36 x 60	439.00
	FH753	-	36 x 72	529.00
<b>LAMINATED WOOD - SQUARE EDGE (1/8" RADIUS)</b>				
	FI733	-	30 x 60	339.00
	FI734	-	30 x 72	399.00
	FD026	-	36 x 60	399.00
	FI738	-	36 x 72	489.00
<b>SHOP TOPS</b>				
	FD004	-	30 x 60	189.00
	FD005	-	30 x 72	244.00
	FD006	-	36 x 60	253.00
	FD007	-	36 x 72	279.00
<b>PLASTIC LAMINATE</b>				
	FD011	-	30 x 60	256.00
	FD012	-	30 x 72	309.00
	FD013	-	36 x 60	319.00
	FD014	-	36 x 72	383.00
<b>STAINLESS STEEL</b>				
	FI271	-	30 x 60	672.00
	FI272	-	30 x 72	730.00
	FI276	-	36 x 60	716.00
	FI277	-	36 x 72	795.00

### D - DOOR

- Made of 18-gauge steel on rollers
- Recessed handles
- Includes: Plunger lock and two keys



Model No.	Description	Wt. lbs.	Price /Each
FH163	Door Set, Lock Included	40	424.00

### E - DRAWERS

- All-welded heavy gauge steel
- 100% full extension with ball bearing slide mechanism
- All locks keyed alike by drawer model
- Includes: locks and two keys
- Aluminum extrusion handles with grey end caps
- Capacity: 100 lbs. per drawer evenly distributed



FH938



FH939

Model No.	Dimensions				Wt. lbs.	Price /Each	
	L"	x	W"	x			H"
FH938	15 3/8	x	20	x	5 5/8	30	211.00
FH939	15 3/8	x	20	x	2 3/4	35	291.00



## MOBILE CABINET BENCHES

- Ideal for maintenance, repair and assembly departments
- Mount one, two or three cabinets from six choices of cabinets
- Heavy-duty 11-gauge steel base, 1 1/4" thick laminated hardwood top, and a push handle
- Four 5" non-marking casters with brakes for smooth, easy rolling
- Doors are reversible, can be opened either left or right side
- All locks keyed alike by pedestal model
- Capacity: 1200 lbs. evenly distributed
- Cabinet frame powder coat finish with grey shell and Kleton blue on doors and drawers
- Shipped knocked down



FH666

FH667

FH668

F1166

F1167

FH669

FH670

FH671

### CONFIGURE YOUR OWN UNIT BY CHOOSING:

1. The pedestal style(s) that suits your needs (to a maximum of three pedestal(s))
2. Add to that the assembly kit, whether it be single, double or triple. Assembly kit includes casters, base and 1 1/4" laminated hardwood top



Assembly Kit

Model No.	Description	Wt. lbs.	Price /Each
<b>1 - PEDESTAL STYLES COMPLETE WITH LOCK &amp; 2 KEYS</b>			
FH666	One door	51	311.00
FH667	Two half doors	52	365.00
FH668	Two small drawers and one half door	75	485.00
FH669	Four large drawers	97	634.00
F1166	Two large drawers	66	422.00
F1167	One large drawer and two small drawers	78	487.00
FH670	Four small drawers and one half door	84	678.00
FH671	Four small drawers and two large drawers	98	838.00
<b>2 - ASSEMBLY KITS</b>			
FH407	Single	35	310.00
FH408	Double	65	420.00
FH409	Triple	95	595.00

## SINGLE PEDESTAL BENCHES

- Heavy gauge steel cabinet with 1" round tube frame
- Top tray lined with a rubber mat
- Full extension drawers with a capacity of 100 lbs. per drawer
- Four 4" non-marking casters with brakes for smooth, easy rolling
- Comes complete with locks and two keys
- Overall dimensions 20" W x 21" D x 37" H
- Capacity: 800 lbs. evenly distributed
- Cabinet frame powder coat finish with grey shell and Kleton blue on doors and drawers



Model No.	Description	Wt. lbs.	Price /Each
FF984	4-drawer cabinet	120	945.00
MH801	Single door cabinet	75	725.00



FF984



MH801

# WORKBENCHES

## INDUSTRIAL DUTY MOBILE SERVICE BENCHES

- Designed for moving heavy parts and tools to the job site
- Four 5" non-marking casters: two rigids and two swivels with brake
- Provides a strong maintenance-free surface to work on
- 16-gauge all-welded steel construction
- Laminated hardwood top
- Overall dimensions: 42" W x 24" D x 37" H
- Shell durable Kleton blue enamel finish
- Cabinets are powder paint grey and Kleton blue
- Shipped assembled
- Capacity: 1200 lbs. evenly distributed



Model No.	Description	Wt. lbs.	Price /Each
ML325	2 Doors	235	1449.00
ML326	1 Drawer/1 Door	190	1329.00
ML327	4 Drawers/1 Door	275	1649.00
ML328	8 Drawers	300	1889.00

\* Review cabinet models on page 122 to create your own mobile service bench.



ML325



ML326



ML327



ML328

## TOOL TOTER CARTS

For safe convenient storage of tools and equipment. An excellent addition to any tool centre.

- Do not waste time looking for your tools and jigs
- Each drawer is 15 1/4" x 23 3/4" x 4 3/4" with padlocking hasp
- Carrier is 18" W x 24" D x 34 1/2" H with 3" hard rubber swivel casters
- Drawer capacity: 50 lbs.
- Shipped knocked down



Model No.	Description	Wt. lbs.	Price/Each
FH210	2 Drawers	55	417.00
FH211	4 Drawers	85	620.00
FH212	2 Drawers and Cabinet	93	635.00

FH210



FH211



FH212



## CABINET TABLES

These sturdy combination storage cabinets and work tables provide safe locked-in storage of valuable tools and parts, while at the same time serving as all-around work tables. Ideal for mounting vises, grinders or small power tools. Heavy gauge steel. Cylinder lock built into handle on door for added security. Powder coat grey finish.

### ONE SHELF CABINETS

- 24" x 24" work area with 2" lip
- Unit is 34" H
- One full size centre shelf adjustable on 3" increments
- 12 cu. ft. of storage space
- Weight: 80 lbs.
- Capacity: 250 lbs. per shelf evenly distributed
- Shipped knocked down

Model No. FF075  
Price/Each \$499.00



FF075

### LOCKING CABINET TABLES

- 36" x 24" table top offers a large work area
- Unit is 34" H
- 2" deep lip prevents supplies from falling off
- Comes with one full-size centre shelf adjustable on 1 1/2" centres and 3" increments
- 18 cu. ft. of storage space
- Weight: 110 lbs.
- Capacity: 250 lbs. per shelf evenly distributed
- Shipped knocked down

Model No. FF076  
Price/Each \$645.00



FF076



FF078

### THREE SHELF CABINETS

- 15 1/2" D x 21" W work surface can be mounted to form a 2" deep tray, or reversed to provide a rimless work area
- Three adjustable shelves, on 2" increments
- 6.2 cu. ft. of storage space
- Unit is 34" H
- Weight: 46 lbs.
- Capacity: 125 lbs. per shelf evenly distributed, 500 lbs. per cabinet
- Shipped knocked down

Model No. FF078  
Price/Each \$323.00



## MOBILE TOOL BOX BENCHES

- A versatile unit combining tool/storage area with a work surface
- Heavy-duty 11-gauge steel top and base
- Four 5" non-marking casters: two rigid and two swivel with brake
- Overall dimensions: 60" W x 22" D x 37" H
- Durable Kleton blue enamel finish
- Capacity: 1200 lbs. evenly distributed

Model No.	Description	Wt. lbs.	Price /Each
FF993	5 Drawers/3 Drawers	285	1657.00
FF994	3 Drawers and Side Shelves	220	1309.00
FF995	5 Drawers and Side Shelves	235	1357.00

### 3-DRAWER CABINETS WITH FLIP TOP COMPARTMENT

- One 22 1/8" W x 16 3/4" D x 2" H drawer
- Two 22 1/8" W x 16 3/4" D x 4" H drawers
- One 26 1/2" W x 18" D x 12 3/8" H flip top compartment
- Colour: Red

### 5-DRAWER CABINETS

- One 22 1/8" W x 16 3/4" D x 2" H drawer
- Two 22 1/8" W x 16 3/4" D x 4" H drawers
- Two 22 1/8" W x 16 3/4" D x 6 1/8" H drawers
- Colour: Red



FF993



FF994



FF995

## MOBILE WORK CENTRES

- Keeps tools and supplies close at hand
- Drawers can be locked with a padlock (not included)
- Integrated tool carrier in push handle and four plastic bins to hold hand tools and small parts
- Drawer dimension: 22 7/8" W x 11 3/4" D x 1 5/8" H and have a full extension capacity of 75 lbs. evenly distributed
- 5" x 1" casters (two rigid, two swivel with brakes) for easy transportation
- Finish: Grey powder coat
- Shipped knocked down
- Total capacity: 500 lbs. evenly distributed

Model No. FH675  
Price/Each \$379.00



## HEAVY DUTY MOBILE WORK STATIONS

- Capacity: 1200 lbs.
- Weight: 226 lbs.
- 16-gauge all welded steel construction
- Includes (9) yellow bins: 4" W x 5" L x 3" H
- Includes (6) drawers: (2) 20-7/16" L x 14-11/16" D x 4-7/8" H and (4) 20-7/16" L x 14-11/16" D x 2-7/8" H
- Durable, textured powder coat finish
- Top surface has a 3" back stop
- Conveniently carry a 6' ladder on back side of cart
- Ergonomic tubular handle has provision to hold two boxes of fluorescent light bulbs



**DURHAM MFG**  
Est. 1922

Model No.	Overall Height"	Overall Width"	Overall Depth"	No. of Shelves	Colour	Price /Each
FL417	40 1/4	18 1/8	52 5/8	1	Grey	1899.00

## EXTREME TOOLS® EX STANDARD SERIES DELUXE TOOL CART

- Drawer slide type: Ball bearing
- Slide drawer capacity: 100 lbs.
- Convenient access to tools by opening the top drawer or opening the lid (patent-pending)
- Secure tubular coded lock and keys
- Sturdy, heavy duty steel construction
- High density foam drawer liners included
- Drawer dimensions: (1) 26.75" W x 20.125" D x 3.75" H, (1) 26.75" W x 20.125" D x 1.75" H, (1) 26.75" W x 20.125" D x 2.75" H (1) 26.75" W x 20.125" D x 3.75" H
- Bottom Shelf Size: 32" W x 21.75" D x 3" H
- Weight: 159 lbs.



TEP605



TEP606



TEP607

Model No.	Mfg. No.	No. of Drawers	Colour	Dimensions L" x W" x H"	Price /Each
TEP605	EX3204TCBK	4	Black	32-1/4 x 22-1/4 x 40-1/2	1149.00
TEP606	EX3204TCBL	4	Blue	32-1/4 x 22-1/4 x 40-1/2	1149.00
TEP607	EX3204TCRD	4	Red	32-1/4 x 22-1/4 x 40-1/2	1149.00



# WORKBENCHES

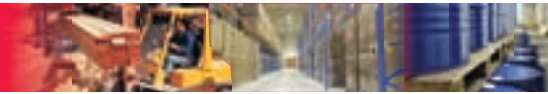

## WALL-MOUNTED SHOP DESK



- Durable carbon steel construction
- Ideal for areas with limited floor space
- Four compartment organizer and slightly sloped writing surface
- Easy to assemble, wall brackets included
- 24" W x 28" D x 3 1/2" H locking drawer on quiet nylon rollers
- Overall dimensions: 34" W x 28" D x 31" H
- Weight: 74 lbs.
- Grey enamel finish

**Model No. FI518**  
**Price/Each \$269.00**

## OPEN FLOOR STYLE SHOP DESK



- Durable carbon steel construction
- Ideal for receiving/shipping clerks, watchmen and shop foremen
- Four compartment organizer and slightly sloped 43" height writing surface
- Optional caster kit to convert to mobile unit
- 24" W x 28" D x 3 1/2" H locking drawer on quiet nylon rollers
- Overall dimensions: 34" W x 30" D x 53" H
- Weight: 93 lbs.
- Grey enamel finish

**Model No. FI519**  
**Price/Each \$329.00**

## CABINET STYLE SHOP DESK



- Durable carbon steel construction
- Same features as the open floor style shop desk, with an added double door locking cabinet
- Four compartment organizer and slightly sloped 43" height writing surface
- Optional caster kit to convert to mobile unit
- 24" W x 28" D x 3 1/2" H locking drawer on quiet nylon rollers
- Overall dimensions: 34" W x 30" D x 53" H
- Weight: 146 lbs.
- Grey enamel finish

**Model No. FI520**  
**Price/Each \$495.00**

### OPTIONAL CASTER KIT

**Model No. FI521**  
**Price/Each \$59.00**



## DELUXE SHOP DESKS



- All-purpose desk for warehouses, shops, shipping and receiving departments
- Comes with: one tray lockable drawer, two double-deep file drawers, one all purpose drawer, desk top sorter, lower shelf
- Overall dimensions: 39" W x 28 3/4" D x 55 1/2" H
- Powder coat grey finish
- Capacity: 275 lbs. evenly distributed
- Weight: 179 lbs.

**Model No. FH459**  
**Price/Each \$1669.00**



## OPEN STYLE SERVICE WRITERS



- This unit provides a locking upper door cabinet with one shelf for added storage space
- 25 3/8" W x 16 1/2" D x 3 1/4" H locking drawer on smooth slides
- Overall dimensions: 31 1/2" W x 21" D x 72 1/2" H
- Powder coat tan finish
- Capacity: 200 lbs. evenly distributed
- Weight: 127 lbs.

**Model No. FH386**  
**Price/Each \$775.00**



## CLOSED STYLE SERVICE WRITERS



- Same features as model FH386 plus a locking lower door compartment with one shelf for storage of large/bulky items
- Overall dimensions: 31 1/2" W x 21" D x 72 1/2" H
- Top and bottom section are fully welded
- Powder coat tan finish
- Capacity: 200 lbs. evenly distributed
- Weight: 171 lbs.

**Model No. FH385**  
**Price/Each \$1045.00**

