

# INSTALLATION & OPERATION MANUAL SUPPLEMENT

## Dual Pendant Control

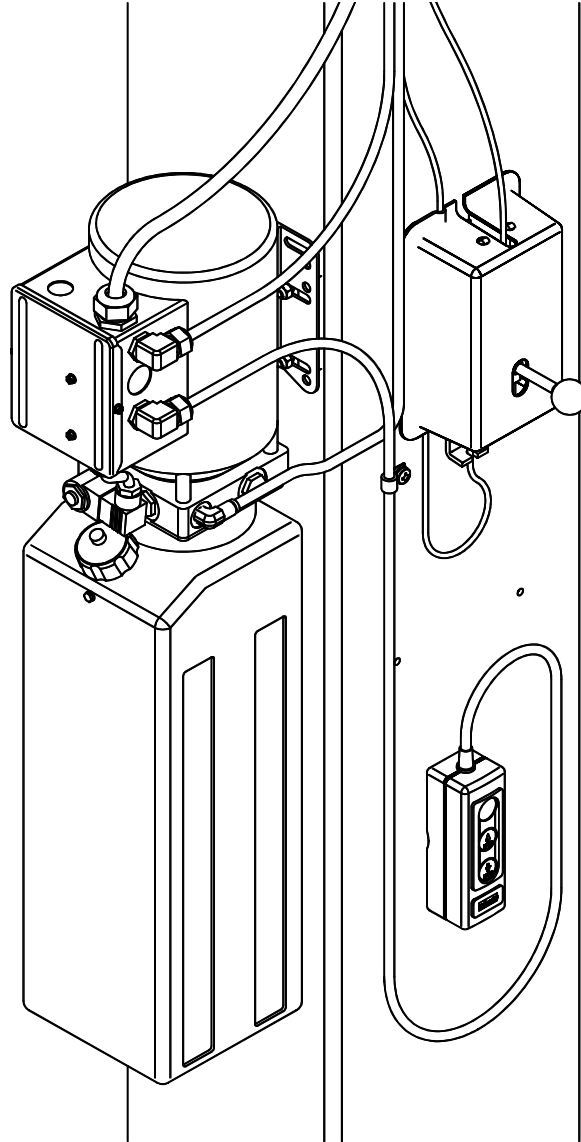

200 Cabel Street, P.O. Box 3944 Louisville, Kentucky 40201-3944  
Email: [sales@challengerlifts.com](mailto:sales@challengerlifts.com) Web site: [www.challengerlifts.com](http://www.challengerlifts.com)

**Office 800-648-5438 / 502-625-0700 Fax 502-587-1933**

**IMPORTANT: READ THIS MANUAL COMPLETELY BEFORE  
INSTALLING or OPERATING LIFT**

**READ ENTIRE MANUAL BEFORE ASSEMBLING, INSTALLING, OPERATING, OR SERVICING THIS EQUIPMENT. PROPER MAINTENANCE AND INSPECTION IS NECESSARY FOR SAFE OPERATION. DO NOT OPERATE A DAMAGED LIFT.**

**INSTALLATION**

FOR NEW LIFT OR RETRO-FIT INSTALL

TOOLS (MINIMUM REQUIRED FOR RETRO-FIT)

- a. 10" adjustable wrench
- b. 7" adjustable pliers
- c. Needle nose pliers
- d. Standard open end wrenches 7/16", 3/4"
- e. 5/16" allen wrench
- f. Sockets: 1/4" (for Ground Screw), 7/8", 1"
- g. Drill with 17/64" bit
- h. 5/16-18NC tap
- i. Wire stripper
- j. Crimping tool for solderless terminals

**For New Lift Install**

(If power unit is already equipped with electric lowering valve and has motor wiring box cover mounted relay)

**Skip to Step 10)**

POWER UNIT RE-CONFIGURING

- 1) Disconnect power to Lift.
- 2) Remove Motor Wiring Box Cover/Pushbutton and discard. (This will be replaced by Blank Cover/Relay Assembly)

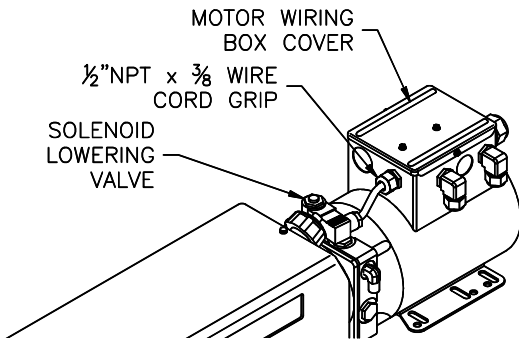

**Fig 1 – Power Unit**

- 3) Remove "knock-outs" from Motor Wiring Box as indicated for Solenoid Lowering Valve and install supplied Straight Cord Grip (1/2" NPT x 3/8" O.D. wire), see **Fig 1**. (Note: 1/2" NPT cord grip fitting uses 7/8" dia. knock-out and 3/4" NPT uses 1 1/8").

- 4) Remove Lowering Valve Assembly (handle & valve cartridge), (**Fig 1**).
- 5) Install Solenoid Lowering Valve supplied, (**Fig 2**).

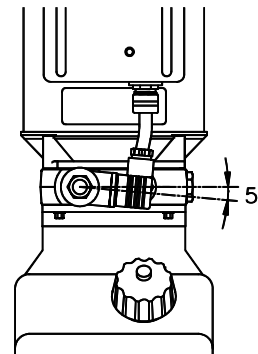

**Fig 2 – Solenoid Lowering Valve**

- 6) Remove "knock-outs" from Motor Wiring Box as indicated for Overhead Limit Switch and Idler and Power Column Pendants.

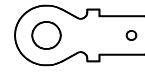

- 7) Install Ground Lug under motor ground screw located in Motor Wiring Box (use 1/4" socket to access ground screw through the Idler Column Pendant "knock-out").

LOCK RELEASE CABLE TAB

(THE POWER COLUMN MUST HAVE A CABLE CASING TIE-OFF TAB ADDED BELOW THE LOCK ASSEMBLY)

- 8) Remove existing Lock Covers and Lock Pawls and discard.
- 9) Drill 17/64" diameter hole and tap 5/16-18NC as indicated in **Fig 3**. Mount Tab using 5/16-18 x 3/8 Lg. Pan Head Screw and 5/16" Split Lock Washer.

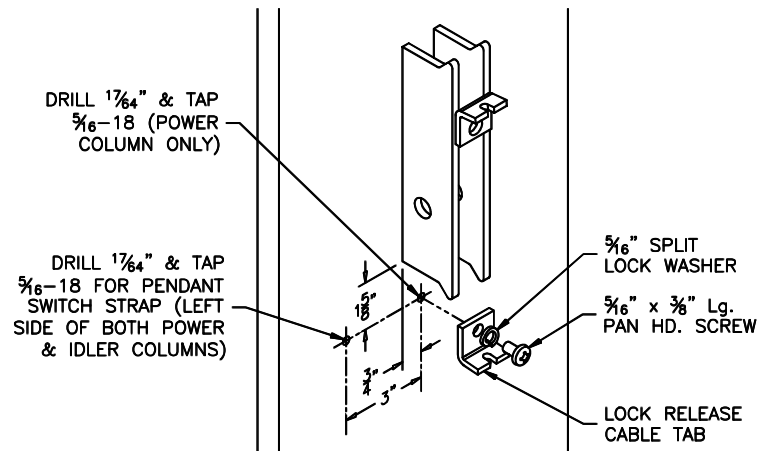

**Fig 3 – Lock Release Tab Location**

LOCKING PAWL

- 10) Attach 1/2" O.D. Extension Spring to hole located on bottom side of both supplied Lock Pawls, **Fig 4**. Install Lock Pawl and Lock Release Clevis on both columns using 5/8" diameter x 1 1/2" lg shoulder bolt and 1/2"-13 nylon lock nut. Attach 3/8" O.D. Extension Spring to upper hole in locking pawl and other end to hole in bracket welded to column as shown in **Fig 4**.

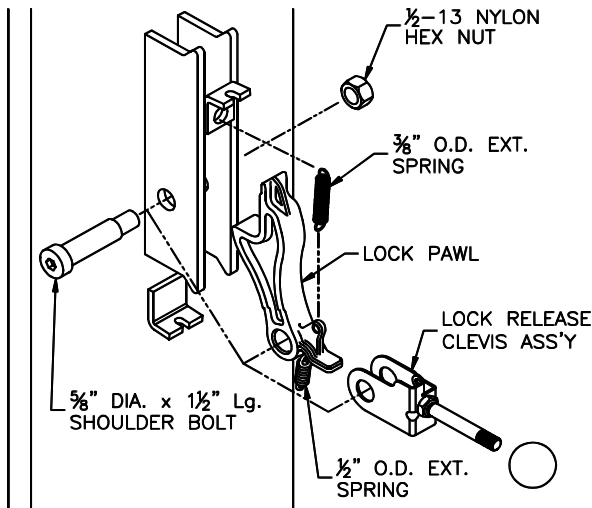

**Fig 4 – Locking Pawl Assembly**

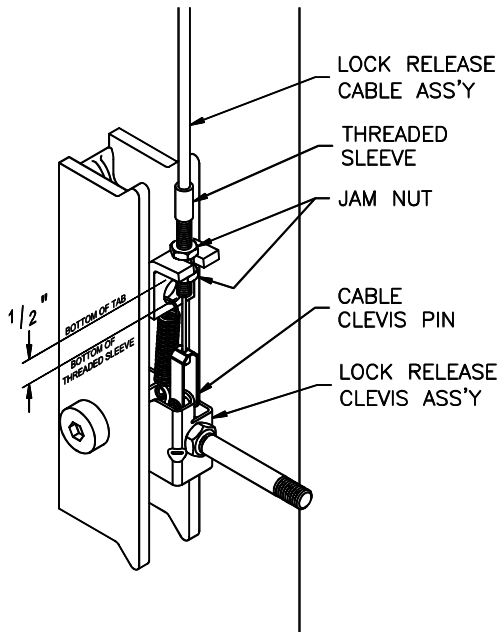

**Fig 5 – Power Column Lock Release Assembly**

DUAL LOCK RELEASE

(TWO LOCK RELEASE CABLES WILL BE ROUTED TOGETHER THROUGH THE LIFT. ONE CABLE ATTACHES TO THE TOP OF THE POWER COLUMN LOCK RELEASE CLEVIS AND THE BOTTOM OF THE IDLER COLUMN LOCK PAWL. THE OTHER CABLE ATTACHES TO THE TOP OF THE IDLER COLUMN LOCK RELEASE CLEVIS AND THE BOTTOM OF THE POWER COLUMN LOCK PAWL)

- 11) Attach Mechanical Lock Release Cable Assembly to Power Column Lock Pawl using the 3/16" diameter x 1/2" long pin and (2) "C" clip retainers found in hardware, **Fig 5**.
- 12) Insert threaded sleeve portion of cable assembly in slot located on tab above locking pawl, **Fig 5**. One jam nut should be located on each side of tab. Position threaded sleeve with 1/2" of thread below tab as indicated in **Fig 5** and tighten jam nuts.
- 13) Route opposite end of cable assembly up Power Column and into column through access slot in bottom of Column Extension. Following the path of the hydraulic line, route cable assembly across overhead clear of moving parts and back out through access slot in bottom of idler side column extension. Attach Cable Assembly to the hydraulic hose with loosely fit wire ties.

**NOTE:** DO NOT kink cable assembly when routing. Tighten and trim wire ties after final cable adjustments have been made

- 14) Attach Adhesive-Backed Tab to Idler Column left of the lock assembly (**Fig 6**). Route Lock Release Cable down left side of Idler Column and secure with loosely fit wire tie to Adhesive-Backed Tab. Attach Cable clevis to 1/2" O.D. Extension Spring.

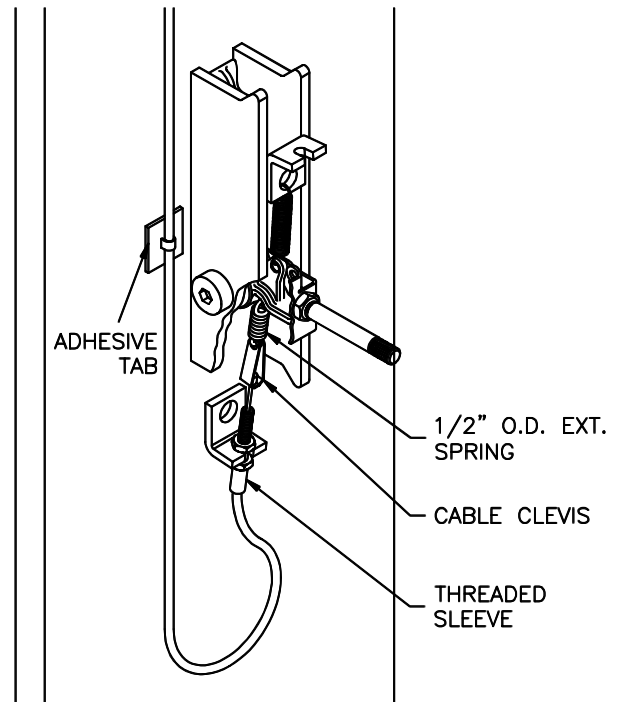

**Fig 6 – Idler Column Lock Release Assembly**

- 15) Insert threaded sleeve portion of cable assembly in slot located on tab below lock pawl, **Fig 6**. With one jam nut located on each side of tab, adjust the threaded sleeve

Dual Pendant Control  
Installation & Operation Supplement

to begin to pull tension on the ½" O.D. spring. Snug jam nuts by hand.

- 16) Repeat **procedures 11 thru 14** with second Lock Release Cable routing from top of Idler Column Lock to bottom of Power Column Lock, (**Figs. 5 & 6**).

**THE LOCK RELEASE CABLE ADJUSTMENT IS NOT COMPLETE UNTIL THE LIFT HAS BEEN LOWERED AND "FINAL ADJUSTMENTS" HAVE BEEN MADE.**

PENDANT SWITCHES

- 17) Hang both pendant switches using supplied 5/16" Line Clamp, 5/16-18 x 3/8 Lg. Pan Head Screw and 5/16" Split Lock Washer (**Fig 7**).

**IMPORTANT: RISK OF EXPLOSION. THE PENDANT CONTROLS HAVE INTERNAL ARCHING OR SPARKING PARTS THAT SHOULD NOT BE EXPOSED TO FLAMMABLE VAPOR. THE PENDANT CONTROLS SHOULD BE LOCATED AT LEAST 18 INCHES (460mm) ABOVE THE FLOOR.**

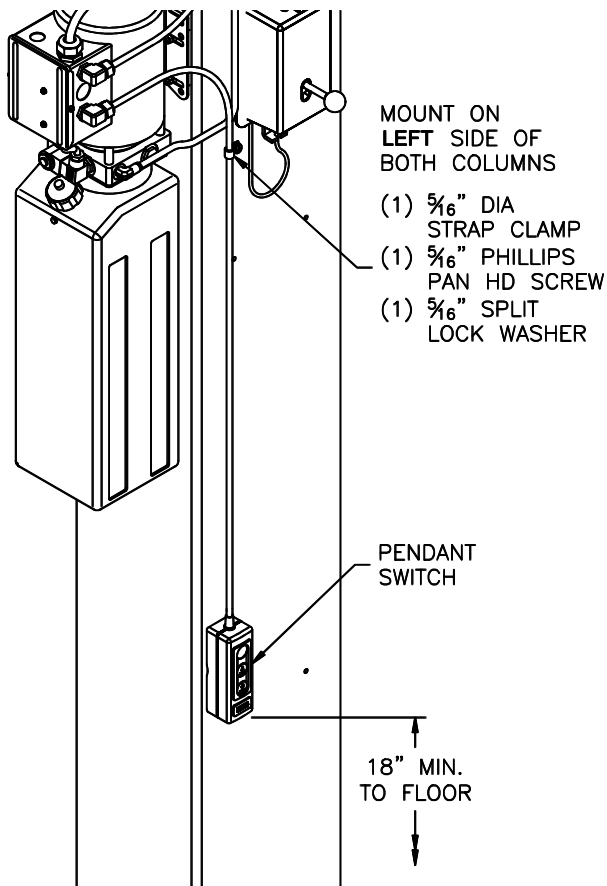

**Fig 7 – Pendant Switch Installation**

- 18) Route Idler Column Pendant Switch cord up and over to the Power Unit following the path of the Lock Release Cable clear of moving parts. Attach with wire ties.

ELECTRICAL

- 19) Connect the Overhead Limit Switch cord, Pendant Switch cords, Solenoid Lowering Valve cord and suitable electrical source to Power Unit as shown in **Fig 8**.

**IMPORTANT:** After wiring has been completed, test operation of Power Unit, Pendant Switches & Overhead Limit switch. While raising lift, operate Overhead Shutoff Bar. Power Unit Motor should stop when Shutoff Bar is raised.

LOCK RELEASE CABLE

- 20) Lower lift to the floor and snap plastic cover over Power Column lock assembly.
- 21) Pull and release Power Column lock release handle while watching Idler Column lock. Adjust lower threaded sleeve cable adjuster jam nuts on Idler Column until Idler Column lock disengages and engages fully. When properly adjusted, the idler column lock should just come to rest against the back of the column when engaged and fully out against the tab when disengaged. Tighten Idler Column lower tab jam nuts.
- 22) Remove plastic lock cover from Power Column and snap plastic cover over Idler Column lock assembly.

**(The following step is a repeat of step 21 for Idler Column lock release handle)**

- 23) Pull and release Idler Column lock release handle while watching Power Column lock. Adjust lower threaded sleeve cable adjuster jam nuts on Power Column until Power Column lock disengages and engages fully. When properly adjusted, the Power Column lock should just come to rest against the back of the column when engaged and fully out against the tab when disengaged. Tighten Power Column lower tab jam nuts.

**IMPORTANT: IF LOCK PAWLS DO NOT FULLY DISENGAGE, DAMAGE MAY RESULT TO IDLER SIDE CARRIAGE AND OR CABLE SYNCHRONIZING SYSTEM.**

- 24) Tighten and trim wire ties.
- 25) Snap plastic cover over each lock assembly (align lock release cable with notches in lock cover flange).

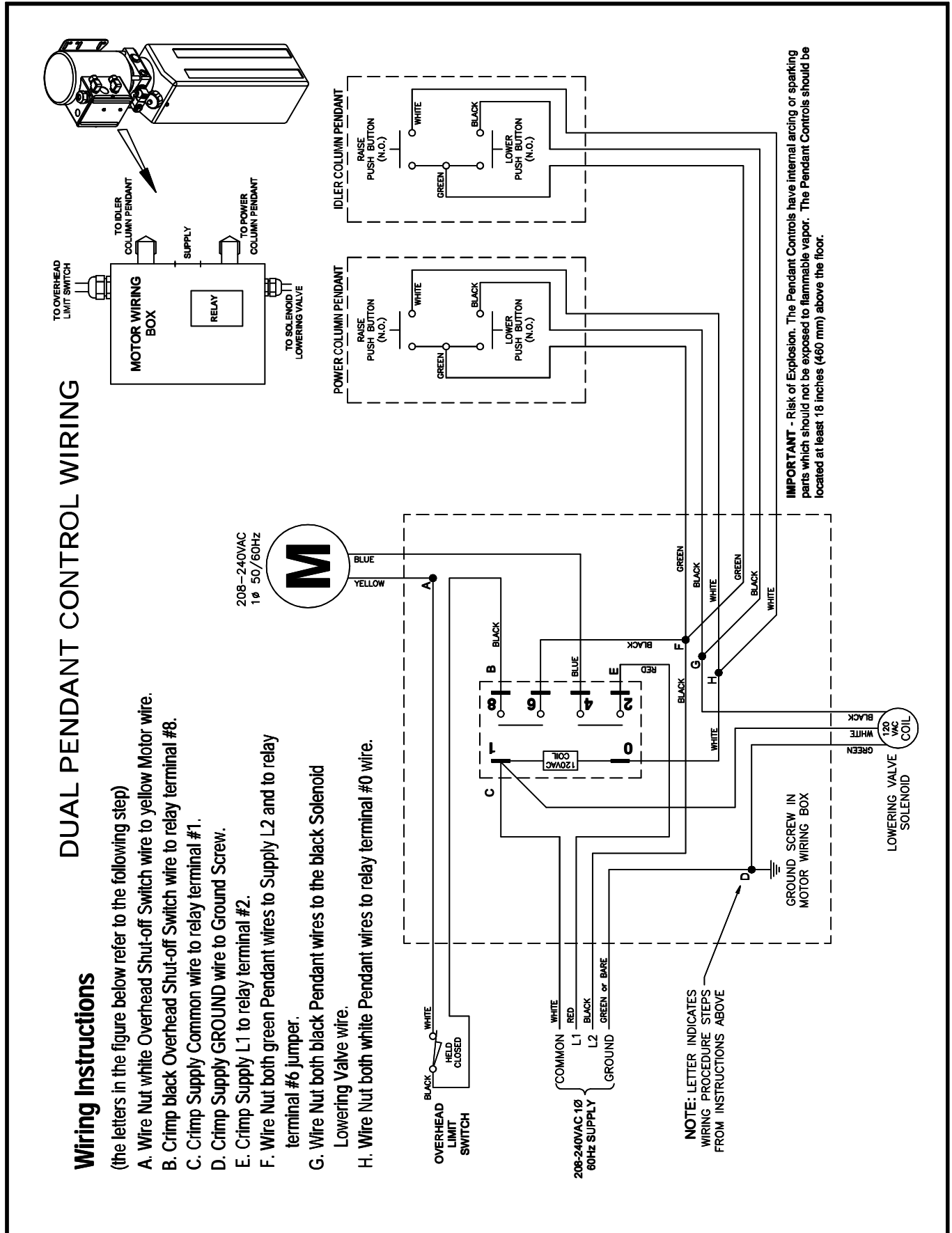

Fig 8 – Electrical Wiring Diagram

# PARTS BREAKDOWN

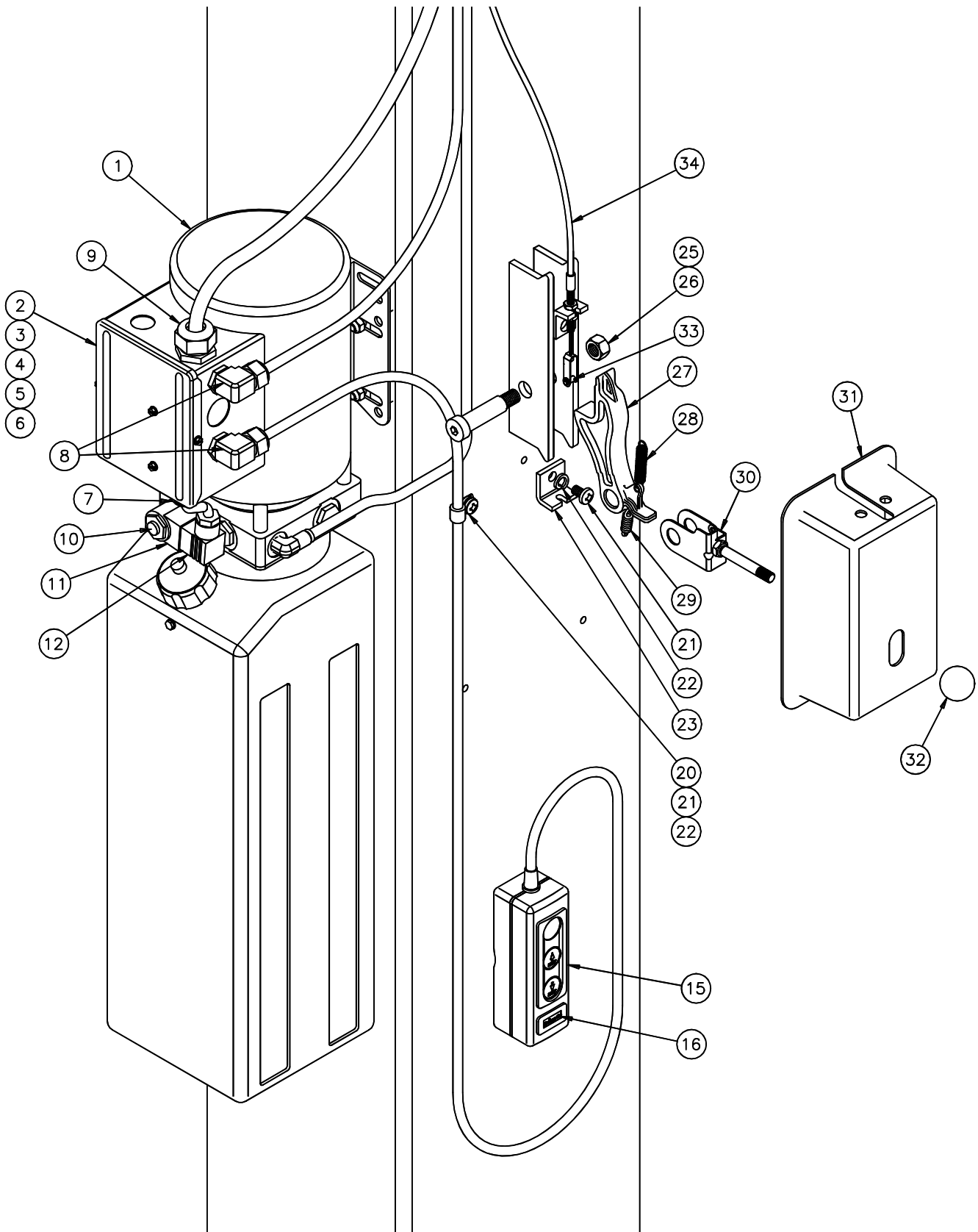

Fig A. Dual Pendant Control

Dual Pendant Control  
Installation & Operation Supplement

**PARTS BREAKDOWN** (continued)

ITEM #	PART #	QTY/ LIFT	DESCRIPTION
1	A1201PC-15	1	MODEL CL9 POWER UNIT, 208-230VAC SINGLE PHASE (includes ITEMS 2, 3, 7, 10, 11, & 12)
	A1201PC-17		MODEL CL10 POWER UNIT, 208-230VAC SINGLE PHASE (includes ITEMS 2, 3, 7, 10, 11, & 12)
2	W-135	1	MOTOR WIRING BOX COVER w/RELAY
3	A1205-25	1	GROUND LUG, #8 STUD-TO-1/4" SPADE ADAPTER
4	A1205-26	5	FEMALE CONNECTOR, 10-12AWG x 1/4" SPADE, FULLY INSULATED
5	A1205-27	1	RED WIRE NUT
6	31120	3	YELLOW WIRE NUT
7	A1205-35	1	CORD GRIP - STRAIGHT, 1/2NPT x .35 O.D. WIRE
8	A1205-36	2	CORD GRIP - 90 deg., 1/2NPT x .35 O.D. WIRE
9	A1205-38	1	CORD GRIP - STRAIGHT, 3/4NPT x .50 O.D. WIRE
10	VF-4009	1	120VAC N.C. CARTRIDGE LOWERING VALVE ( w/o COIL)
11	EF-1092	1	120VAC SOLENOID LOWERING COIL
12	2000105	1	LOWERING COIL HIRSCHMANN CONNECTOR w/CORD ASS'Y
15	A1205-40P	1	PENDANT CONTROL SWITCH - POWER SIDE (5 ft. CORD)
	A1205-40I	1	PENDANT CONTROL SWITCH - IDLER SIDE (34 ft. CORD)
16	A1205-34	2	"Challenger" DECAL .32x.89
20	A1122-6	2	CABLE CLAMP 5/16" I.D.
21	10335	2	5/16-18NC x 3/8" Lg. PHILIPS PAN HEAD SCREW
22	31331	2	5/16 SPLIT LOCK WASHER
23	A1130	1	TAB (LOCK RELEASE)
25	30020	2	LOCK PIN (5/8 x 1 1/2" Lg. SHOULDER BOLT)
26	37013	2	LOCK PIN RETAINER (1/2-13NC HEX LOCK NUT)
27	A1140	2	LOCK PAWL (DUAL CONTROL)
28	A1131	2	LOCK SPRING (3/8" O.D.)
29	A1132	1	CABLE SPRING (1/2" O.D.)
30	A1141	2	LOCK RELEASE CLEVIS ASSEMBLY
31	A1133	2	LOCK COVER
32	36096	1	BALL HANDLE
33	37119	1	CLEVIS PIN KIT
34	A1135-0	1	LOCK RELEASE CABLE ASSEMBLY - MODEL CL9 (11'-8" OVERALL HT.)
	A1135-1		LOCK RELEASE CABLE ASSEMBLY - MODEL CL9-1 (12'-8" OVERALL HT.)
	A1135-2		LOCK RELEASE CABLE ASSEMBLY - MODEL CL9-2 (13'-8" OVERALL HT.)
	A2135-0		LOCK RELEASE CABLE ASSEMBLY - MODEL CL10 (11'-8" OVERALL HT.)
	A2135-2		LOCK RELEASE CABLE ASSEMBLY - MODEL CL10-2 (13'-8" OVERALL HT.)
	A2135-3		LOCK RELEASE CABLE ASSEMBLY - MODEL CL10-3 (14'-8" OVERALL HT.)