

Specifications				(The wire rope composition is a manufacturer recommendation.)
Load Rating Wire Rope Tension	4,900N (=500kgf)	Handle Force	Handle Length 250mm Wire Rope Tension 4,900N	84N (=8.5kgf)
Wire Rope Diameter	φ6mm (6×37), JIS	Standard Accessories		One Handle
Gear Ratio	1/8.9	Painting		Melamine Resin Coating At Two Layers Painting Color Drum : Black (Munsell N1 Semi Gloss) Others : Munsell 7.5YR6/11
Effective Handle Length	250mm (Maximum)			
Weight	17.8kg (Winch+Handle)			

※Model MC winch is designed only for horizontal pulling.
Never use this winch for vertical lifting.
It may result in serious accident and breakage of the winch.

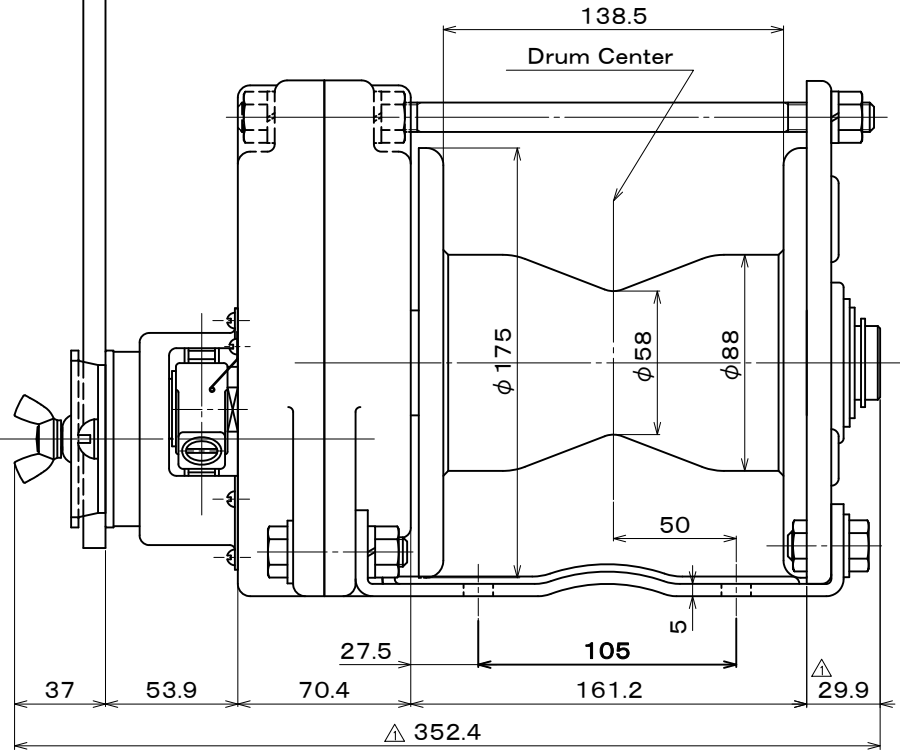
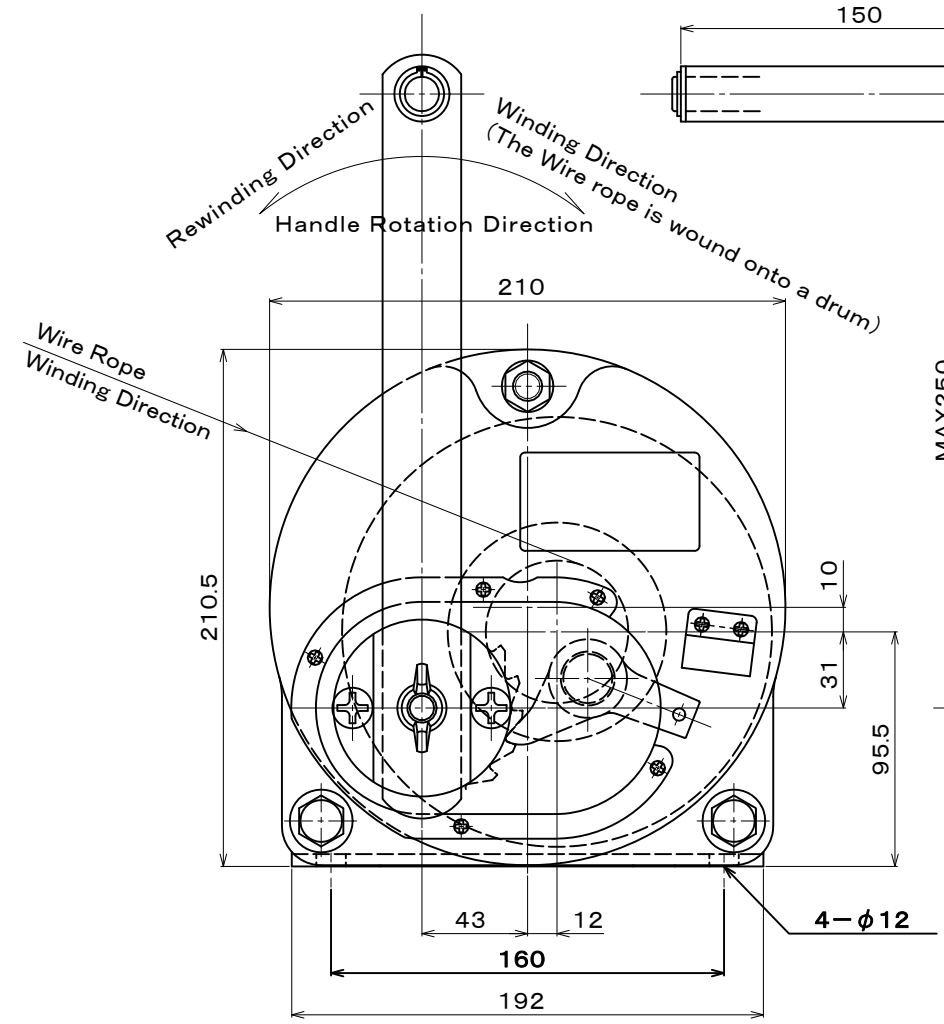

△ ×				図面番号 / DRAWING No.	改訂番号 / REVISION No.	お客様 / CUSTOMER	符号 MARK	項目 PARTICULARS	材料 MATERIAL	数量 QTY	単体合計 PER ONE TOTAL	備考 REMARKS
△ ×				MC5-140226-01E	01							
△ ×	16-08-09	Deleted the quick winding hole of handle	武松	承認 / APPROVED	検図 / CHECKED	作成 / DRAWN	図面名 / TITLE					
△ × 2	16-08-09	Shaft end deleted	武松	設計部 '16.08.09 米澤	設計部 '16.08.09 松嶺	設計部 '16.08.09 武松	MAXPULL WINCH CAPSTAN TYPE MODEL MC-5					
改訂 / REVISION							投影法 / PROJECTION METHOD 第三角法 THIRD ANGLE PROJECTION 尺度 / SCALE 台数 / QTY	MAXPULL MACHINERY & ENGINEERING CO. LTD. マックスプル工業株式会社				