

INSTALLATION, OPERATION & MAINTENANCE MANUAL SUPPLEMENT

Cassette Lift Runway Kit

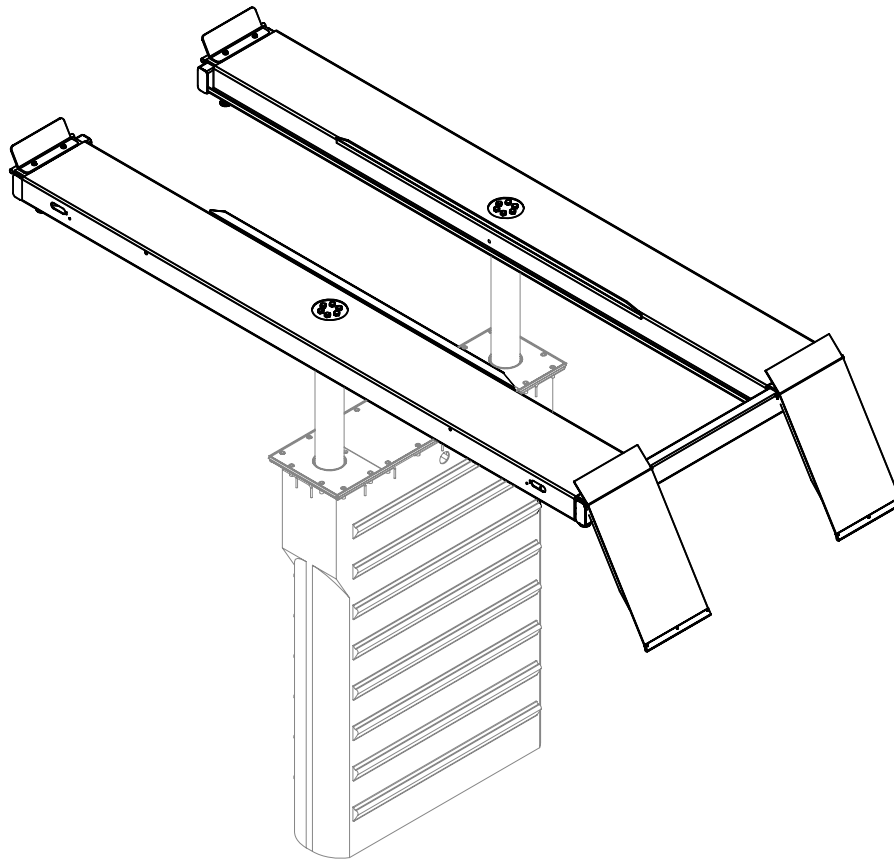

Model CS8RK

(8,000 lb Capacity)

for use with CHALLENGER LIFTS Model CS1020 Series Lifts

200 Cabel Street, P.O. Box 3944 Louisville, Kentucky 40201-3944

Email: sales@challengerlifts.com Web site: www.challengerlifts.com

Office 800-648-5438 / 502-625-0700 Fax 502-587-1933

**IMPORTANT: READ THIS MANUAL COMPLETELY BEFORE
INSTALLING or OPERATING LIFT**

GENERAL SPECIFICATIONS

SPECIFICATIONS	CS8RK
A Length Overall	18' 2 9/16"
B Width Overall	6' 6 1/2"
C Height of Runways	7 3/16"
D Width of Runways	20"
E Width Between Runways	40 1/4"
F Maximum Wheelbase *	157 1/2"
G Rise Height	75 3/16"
Lifting Capacity	8,000 lbs.
Min. Recommended Bay Size	10' x 22'

* Wheelbase is based on a tire diameter of 30"

**There is no Minimum Wheel base when vehicle is centered.

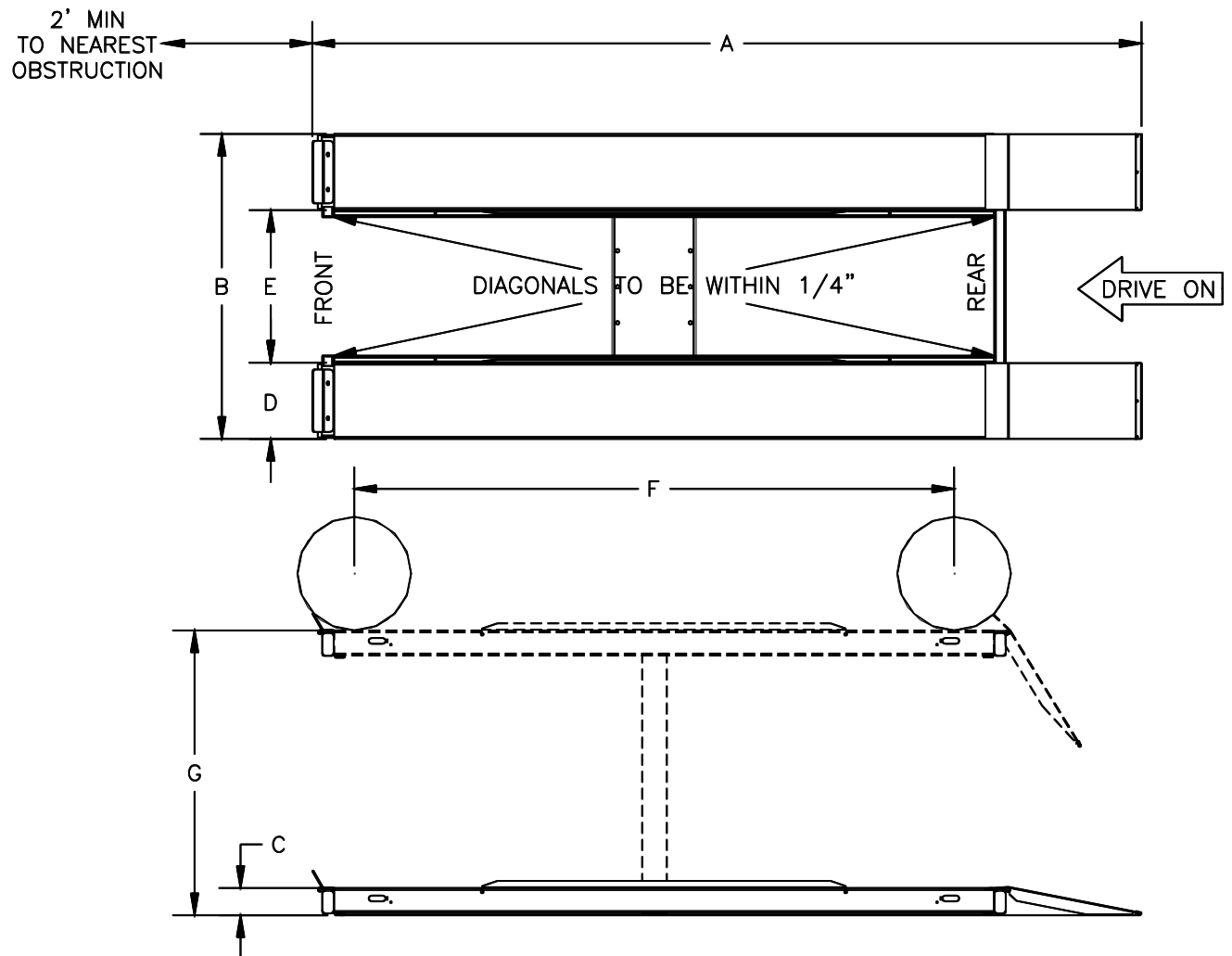

Fig 1 – General Specifications and Service Bay Layout

VERTICAL CLEARANCE

Check the height of the area where the lift is to be installed. Clearance should be calculated based on the full raised height of the lift.



WARNING Failure by purchaser to provide adequate clearance could result in unsatisfactory lift performance, property damage, or personal injury.

SAFETY NOTICES AND DECALS

For your safety, and the safety of others, read and understand all of the safety notices and decals included here.

READ ENTIRE MANUAL BEFORE ASSEMBLING, INSTALLING, OPERATING, OR SERVICING THIS EQUIPMENT.

PROPER MAINTENANCE AND INSPECTION IS NECESSARY FOR SAFE OPERATION.

DO NOT OPERATE A DAMAGED LIFT.

Safety decals similar to those shown here are found on a properly installed lift. Be sure that all safety decals have been correctly installed on the Power Unit reservoir. Verify that all authorized operators know the location of these decals and fully understand their meaning. Replace worn, faded, or damaged decals promptly.



WARNING Do not attempt to raise a vehicle on the lift until the lift has been correctly installed and adjusted as described in this manual.

SAFETY WARNING LABELS FOR INGROUND LIFTS

Lift Owner/User Responsibilities:

- A. This Safety Warning placard **SHALL** be displayed in a conspicuous location in the lift area.
- B. Use one of the mounting arrangements illustrated on back of this placard.
- C. These Safety Warning labels supplement other documents supplied with the lift.
- D. Be certain all lift operators read and understand these labels, operating instructions and other safety related information supplied with the lift.

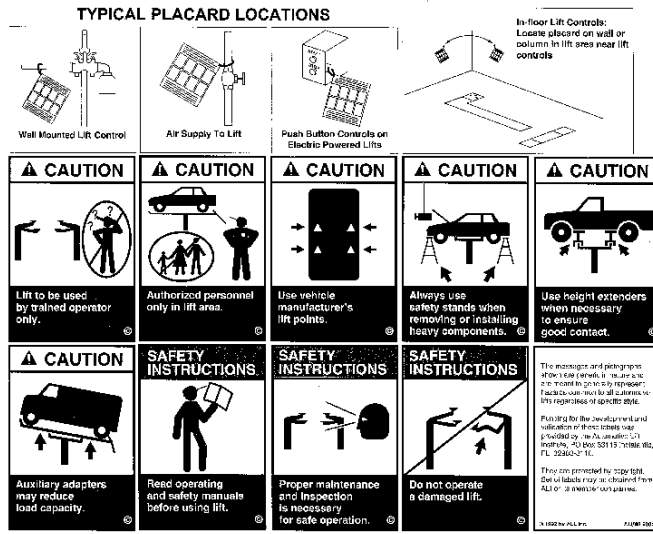
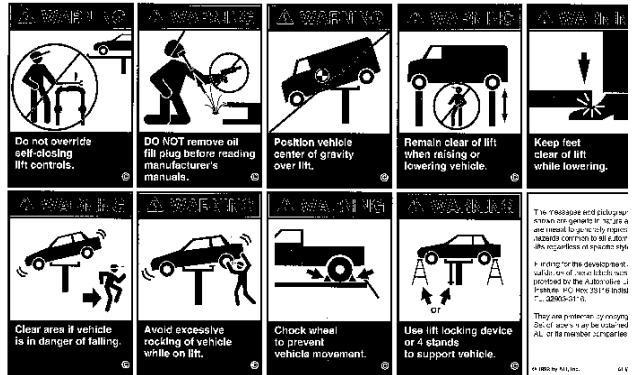

RECEIVING

The shipment should be thoroughly inspected as soon as it is received. The signed bill of lading is acknowledgement by the carrier of receipt in good condition of shipment covered by our invoice.

If any of the goods called for on this bill of lading are shorted or damaged, do not accept them until the carrier makes a notation on the freight bill of the shorted or damaged goods. Do this for your own protection.

NOTIFY **Challenger Lifts** AT ONCE if any hidden loss or damage is discovered after receipt.

IT IS DIFFICULT TO COLLECT FOR LOSS OR DAMAGE AFTER YOU HAVE GIVEN THE CARRIER A CLEAR RECEIPT.

File your claim with **Challenger Lifts** promptly. Support your claim with copies of the bill of lading, freight bill, and photographs, if available.

Component Packing List

ITEM #	QTY/ LIFT	DESCRIPTION
1	1	DRIVER SIDE RUNWAY
2	1	PASSENGER SIDE RUNWAY
3	2	END TUBE
4	1	CROSS TUBE
5	2	ENTRANCE RAMP WELD
6	1	HARDWARE BOX
7	2	WHEEL CHOCK
8	2	FRONT STOP
9	2	SHIPPING BRACKET
10	2	½" SHIPPING HARDWARE

INSTALLATION

IMPORTANT: Always wear safety glasses while installing lift.

TOOLS (MINIMUM REQUIRED)

- Tape measure, 25ft
- 10" & 12" adjustable wrench
- Standard open end wrenches 3/8", 7/16", 1/2", 9/16", 5/8", (2) 11/16", 3/4", 15/16"
- Box knife
- Needle nose pliers
- Torque wrench: 120 foot pounds minimum with 1 1/8" socket

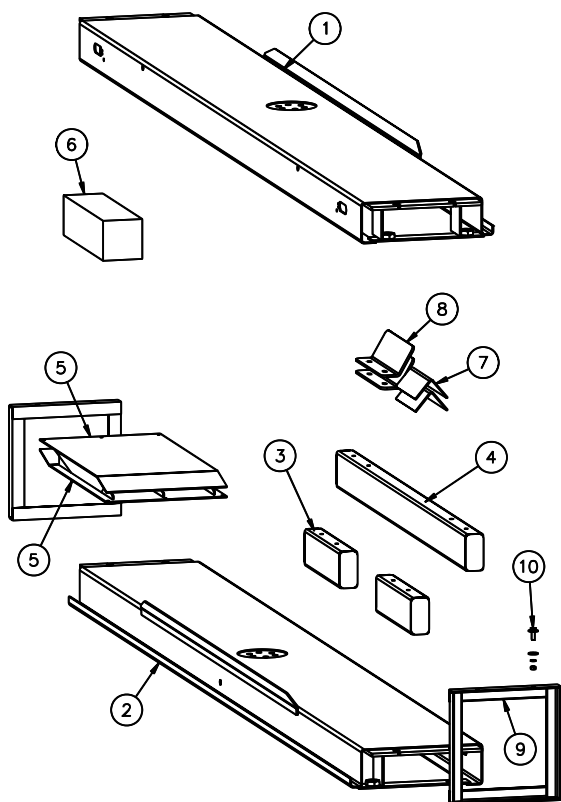

Fig 2 – Package Components

Assembly

- Position the runways over the lift plungers and loosely install ¾-10 x 7 bolts.
- Attach Rear Cross Tube using the ½-13 Flange head bolts.
- Check to insure the runways are parallel to one another (Diagonals within ¼") and torque the ¾-10 x 7 bolts from step one to 120 ft-lbs.
- Assemble the approach ramps to the closed end with the ramp hinge pins and cotter keys.
- Assemble the front stops and end tubes to the front side of the runways using the ½-13 Flange Head bolts.
- Raise the lift and assemble the adjustment feet. There are 4 feet across the open end and 2 on the outside of the closed end.
- Lower the unit completely and level the runways with the adjustment screws. Once the runways are level lock in place using the 1 3/8-6 Jam nuts.

Owner/Operator Checklist

SAVE THESE INSTRUCTIONS deliver them to owner/user/employee along with other materials furnished with this lift.

Demonstrate the operation of the lift to the owner/operator and review correct and safe lifting procedures using the **Lifting It Right** booklet as a guide.

Complete the Installation Checklist/Warranty Validation questionnaire with the owner. Review the terms of the warranty registration card, and return the card and a copy of the questionnaires to:
Challenger Lifts, Inc.
200 Cabel Street
Louisville, KY. 40206

Safety Notices and Decals

This product is furnished with graphic safety warning labels, which are reproduced on page 3 of these instructions. Do not remove or deface these warning labels, or allow them to be removed or defaced. For your safety, and the safety of others, read and understand all of the safety notices and decals included.

Owner/Employer Responsibilities

This lift has been designed and constructed according to ANSI/ALI ALCTV-1998 standard. The standard applies to lift manufactures, as well as to owners and employers. The owner/employer's responsibilities as prescribed by ANSI/ALI ALOIM-2000, are summarized below. For exact wording refer to the actual standard provided with this manual in the literature pack.

The Owner/Employer shall insure that lift operators are qualified and that they are trained in the safe use and operation of the lift using the manufacturer's operating instructions; ALI/SM 93 - 1, ALI Lifting it Right safety manual; ALI/ST-90 ALI Safety Tips card; ANSI/ALI ALOIM-2000, American National Standard for Automotive Lifts-Safety Requirements for Operation, Inspection and Maintenance; ALI/WL Series, ALI Uniform Warning Label Decals/Placards; and in case of frame engaging lifts, ALI/LP-GUIDE, Vehicle Lifting Points/Quick Reference Guide for Frame Engaging Lifts.

The Owner/Employer shall establish procedures to periodically inspect the lift in accordance with the lift manufacturer's instructions or ANSI/ALI ALOIM-2000, American National Standard for Automotive Lifts-Safety Requirements for

Operation, Inspection and Maintenance; and the employer shall insure that the lift inspectors are qualified and that they are adequately trained in the inspection of the lift.

The Owner/Employer shall establish procedures to periodically maintain the lift in accordance with the lift manufacturer's instructions or ANSI/ALOIM-2000, American National Standard for Automotive Lifts-Safety Requirements for Operation, Inspection and Maintenance; and the employer shall insure that the lift maintenance personnel are qualified and that they are adequately trained in the maintenance of the lift.

The Owner/Employer shall maintain the periodic inspection and maintenance records recommended by the manufacturer or ANSI/ALI ALOIM-2000, American National Standard for Automotive Lifts-Safety Requirements for Operation, Inspection and Maintenance.

The Owner/Employer shall display the lift manufacturer's operating instructions; ALI/SM 93 - 1, ALI Lifting it Right safety manual; ALI/ST-90 ALI Safety Tips card; ANSI/ALI ALOIM-2000, American National Standard for Automotive Lifts-Safety Requirements for Operation, Inspection and Maintenance; and in the case of frame engaging lift, ALI/LP-GUIDE, Vehicle Lifting Points/Quick Reference Guide for Frame Engaging Lifts; in a conspicuous location in the lift area convenient to the operator. Demonstrate the operation of the lift to the owner and review correct and safe lifting procedure, using the "Lifting It Right " booklet as a guide.

Important Safety Instructions

When using your garage equipment, basic safety precautions should always be followed, including the following:

- 1 Read all instructions.
- 2 Care must be taken as burns can occur from touching hot parts.
- 3 To reduce the risk of fire, do not operate equipment in the vicinity of open containers of flammable liquids (gasoline).
- 4 Adequate ventilation should be provided when working on operating internal combustion engines.
- 5 Keep hair, loose clothing, fingers, and all parts of body away from moving parts.
- 6 To reduce the risk of electric shock, do not use on wet surfaces or expose to rain.
- 7 Use only as described in this manual. Use only manufacturer's recommended attachments.

Save These Instructions

LIFTING A VEHICLE

Drive vehicle onto lift. Set parking brake and/or use wheel chocks that are provided with lift.

When the vehicle has reached the desired working height, release the power pack button, and lower the vehicle until the safety lock is engaged. The vehicle should remain level when lock is engaged.

IMPORTANT, Before walking under the lift insure that the lock is properly engaged.

It is not safe to work under the vehicle unless the lock is engaged, and the vehicle is level.

LOWERING A VEHICLE

Insure that the area under the vehicle is clear of personnel and tools.

Raise the vehicle until the lock is free.

Disengage the lock by depressing the palm button and holding it.

Lower the vehicle by depressing the lowering valve handle. Watch lift to insure that the lift is lowering evenly. Continue to lower the vehicle until the runways rest on the floor. It is important to fully lower the lift to release hydraulic pressure on the system.

Maintenance

The following maintenance points are suggested as the basis of a preventive maintenance program. The actual maintenance program should be tailored to the installation. See ANSI/ALI ALOIM booklet for periodic inspection checklist and maintenance log sheet.

If lift stops short of full rise or chatters, check fluid level, vehicle position and bleed both cylinders per Installation Instructions.

Replace all Safety, Warning or Caution Labels if missing or damaged.

To avoid personal injury, permit only qualified personnel to perform maintenance on this equipment.

IMPORTANT ! Failure to keep lift free of corrosive agents and solvents will lead to reduced service life, which could result in property damage and/or personal injury.

If any problems are encountered, contact your local service representative

Daily

- Drain Water from air supply to avoid contamination of lock release components.
- Check lock operation. The lock operation should be heard as lift is raised.
- Keep area around lift / containment assembly clean and free of dirt, sand, water, etc. to prevent scoring of the plunger
- Remove excess grease and debris from plunger by wiping them down with a clean cloth.

Monthly

- Check fluid level in the power unit.
- Check for proper torque on all superstructure bolts (120 ft-lbs.).
- Grease Lift Guide bearings using Mobil 1 SCH1500 synthetic grease. Each guide bearing is supplied with a grease zerk and should take 10-12 pumps (hand pump only) while raising and lowering the lift empty.

Parts Breakdown

Model CS8RK

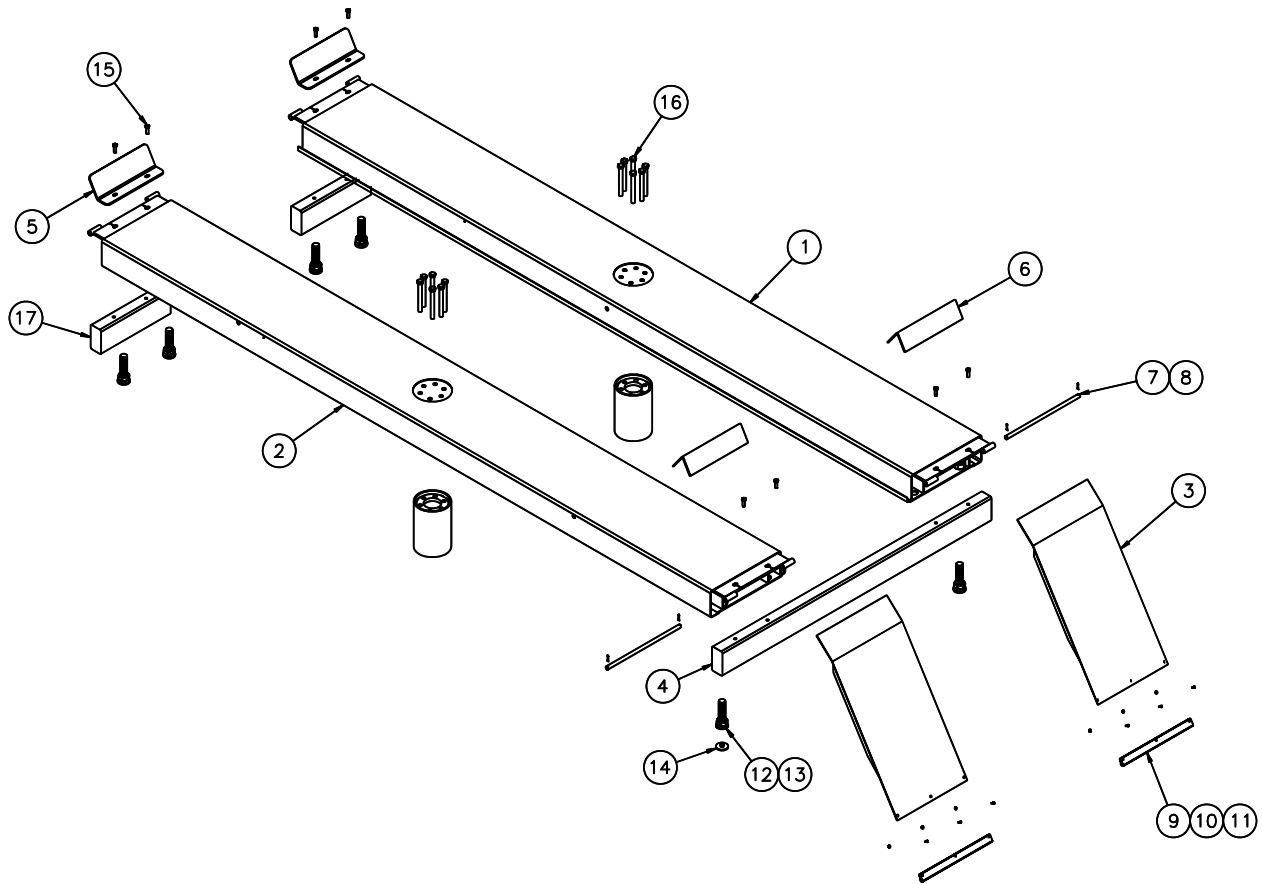

ITEM #	QTY	PART #	DESCRIPTION
1	1	16710R	Passenger Side Runway
2	1	16710L	Driver Side Runway
3	2	40161	Entrance Ramp
4	1	16715	Cross Tube
5	2	40266	Front Stop
6	2	40265	Wheel Chock
7	2	40165	Hinge Pin
8	4	40126	Cotter Pin
9	2	40168	Ramp Slide
10	6	31062	1/4-20 x 3/4 Pan Head Screw
11	6	40085	1/4-20 Hex Nut
12	6	16712	Adjustment Screw
13	6	A1096	1 3/8-6 Hex Jam Nut
14	6	40425	Wear Button
15	8	40083	1/2-13 x 1 1/4 Hex Flange Head Bolt
16	12	16711	3/4-10 x 7 Grade 8 Hex Head Bolt
17	2	16720	End Tube

IMPORTANT!!!

Replace all worn or broken parts with **genuine Challenger Lifts Inc.** parts. Contact your local *Challenger Lifts* parts distributor for pricing and availability. Call 502-625-0700 for the closet parts distributor in your area.