

ooc brown & sharpe



Global

Coordinate Measuring Machines

The world's most versatile line of CMMs

Global versatility... ...made to measure to suit every need.

Global® coordinate measuring machines (CMMs) by Brown & Sharpe offer the most technologically advanced product line in 3D metrology available today. The Global Silver Edition platform is designed to deliver superior performance in all machine characteristics, including accuracy, speed, environment, reliability and ease of use. Global has been designed to be adaptable to changes in technology—making it easy to integrate new, more advanced sensors as they are developed—to help your business stay competitive today and long into the future.

Features to meet nearly every measurement application include:

- Indexing probe heads for easy access to common features and improved throughput by avoiding rack tool changes for different orientations.
- Fixed probe heads for accessibility into deep features that cannot be reached with indexing probe heads.
- A wide variety of data collection modes including tactile scanning of geometric and freeform features, non-contact laser scanning, optical imaging and point-to-point measurement.

Global CMMs are fully supported by Hexagon Metrology's worldwide service and support network of metrology experts, offering unmatched personalized assistance to our customers. The performance of all Global CMMs is checked and certified through the most rigorous application of test procedures specified by either B89 or ISO standards for CMMs.

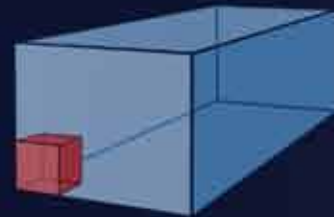

Tailored to Fit

Global CMMs are available in a remarkable range of standard sizes, so you can choose from a work envelope of 500 x 500 x 500mm all the way up to 2,000 x 4,000 x 1,800mm.

Global Silver Edition technology combines cutting-edge mechanical innovations, state-of-the-art motion controllers, advanced temperature compensation models and PC-DMIS—the world's most advanced and most popular metrology software—to create the perfect solution for today's ever changing manufacturing environment.

- New Adaptive Scanning technology automatically determines optimal scanning parameters based on nominal feature values, tolerance and surface finish.
- Improved scanning throughput—35% faster than previous Globals.
- Advanced scanning controller technologies: DC240C, DC800 and B4
- All-aluminum ultra-rigid frame offers both a high strength-to-weight ratio and high thermal diffusivity to help eliminate temperature gradients, which can greatly influence measuring uncertainty.
- Exclusive triangular cross-section bridge beam design provides optimum moment of inertia for minimum deflection while operating at high accelerations.
- High-rigidity aluminum alloy Z spindle provides enhanced performance while using vertically extended tooling.
- Heavy, stable granite table inherently resists vibrations.
- One-piece table construction with patented precision machined dovetail guideways improves accuracy and repeatability.
- Tuned elastomeric passive dampening system provides external vibration isolation.
- Remotely mounted drive motors reduce moving mass for faster bridge settling time and help dissipate heat away from the machine frame.
- High-resolution METALLUR® scales.
- Small footprint-to-measuring volume ratio makes it easy to fit in tight spaces.



Global precision

Three dimensional motion interpolation (FLY) allows the machine to move along optimized paths between points, eliminating unnecessary stops and creating fluid machine motion. This provides:

- Up to 40% increased throughput
- Smooth, continuous path movements between points
- More efficient data collection

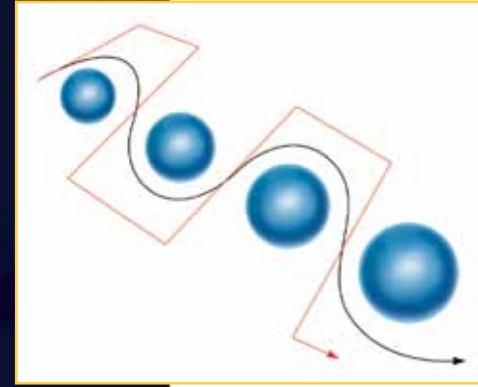

FLY provides optimized motion control, more efficient data collection and unmatched throughput.

Global flexibility

The Global line of CMMs brings superior measuring technology to a wide range of operating environments, from the lab to the shopfloor. The most critical environmental concern for metrology applications is temperature changes. Global's innovative thermal compensation model, called CLIMA, offers high performance in the lab at 18–22°C (65–72°F), as well as enhanced performance for standard room temperature at 16–26°C (61–79°F).

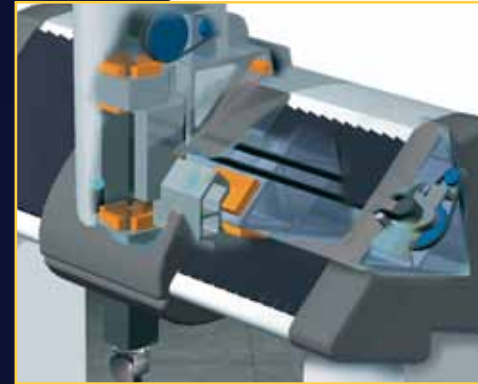

Steel reinforced closed-loop belt drive is precision engineered with elliptical tooth profile to reduce machine vibration at high scanning speeds.

A new Global Silver Edition Shop Floor model combines high-accuracy performance with the ability to operate in harsh shop floor environments and thermal conditions. An extensive network of thermal sensors, advanced structural thermal compensation algorithms and scales with a certified coefficient of thermal expansion all contribute to remarkable accuracy performance of an extended temperature range of 15–30°C (59–86°F).

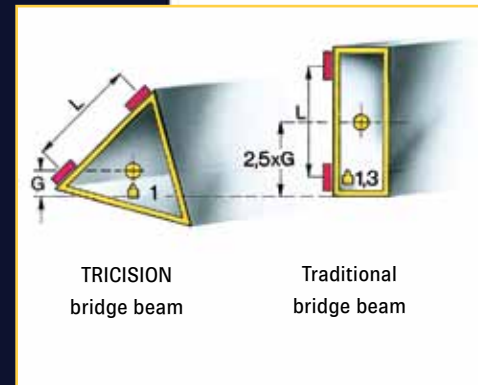

Global's TRICISION extruded triangular cross section bridge beam enhances dimensional stability for superior metrology performance.

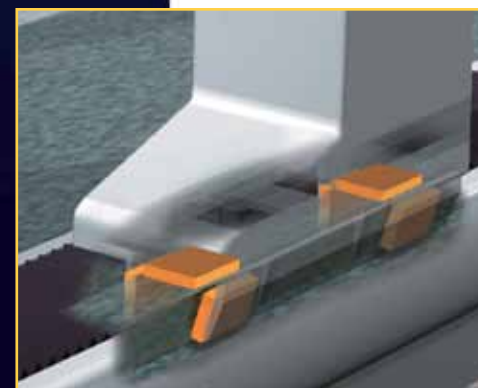

Wrap-around air bearings on precisely machined dovetail guideways provide optimum measuring repeatability and long-term system stability. Easy-maintenance, pre-loaded Belleville springs ensure constant force over the machine's entire travel distance.

global choices



Six attractively priced Global Silver Edition versions—Classic, Performance, Advantage, SF, Reference Xi and Extra—offer different levels of popular standard features and a wide range of sizes to suit most every application. Additional options are also available to customize your Global to your requirements.

Classic

Global Classic is the most cost-effective solution to common shop measurement and inspection applications. Available in configurations to support touch-triggers, Classic is ideal as a first CMM, for multiple-unit deployments, or as a cost-effective way to add extra automated inspection capacity to your quality program.

Standard Package

- Probe: TESASTAR-i manual indexing probe head
- Software: PC-DMIS PRO
- Control: UMP360 touch trigger controller
- Accessories: Computer package, desk, installation, training, warranty
- Options: Upgraded probes and software



Performance

The best solution for high-tolerance parts and more sophisticated measurement tasks that require the assistance of CAD models. Global Performance comes standard with a touch-trigger probe, temperature compensation, as well as advanced software with CAD capability, training and warranty. The Performance model also has the added benefit of being easily upgraded to accommodate a variety of contact and non-contact scanning sensors.

Standard Package

- Probe: TESASTAR-sm motorized probe head and TESASTAR-mp touch trigger probe
- Software: PC-DMIS CAD
- Control: DC240C Controller
- Accessories: Computer package, desk, installation, training, warranty
- Options: Upgraded probes and software

Advantage

An advanced package that provides the combined performance of accuracy and speed, Global Advantage comes standard with a high-performance analog scanning probe, thermal compensation and advanced software with CAD and additional capabilities. The Advantage also includes the highest performance drives of all Global packages, bringing its top acceleration up to 4.3m/s^2 , for maximum measuring throughput. The Advantage also can be easily upgraded to accommodate a variety of contact and non-contact scanning sensors.

Standard Package

Probe: TESASTAR-sm motorized probe head and LSP-X1s analog scanning probe
Software: PC-DMIS CAD++
Control: DC800 Controller
Accessories: Computer package, desk, installation, training, warranty
Options: Upgraded probes

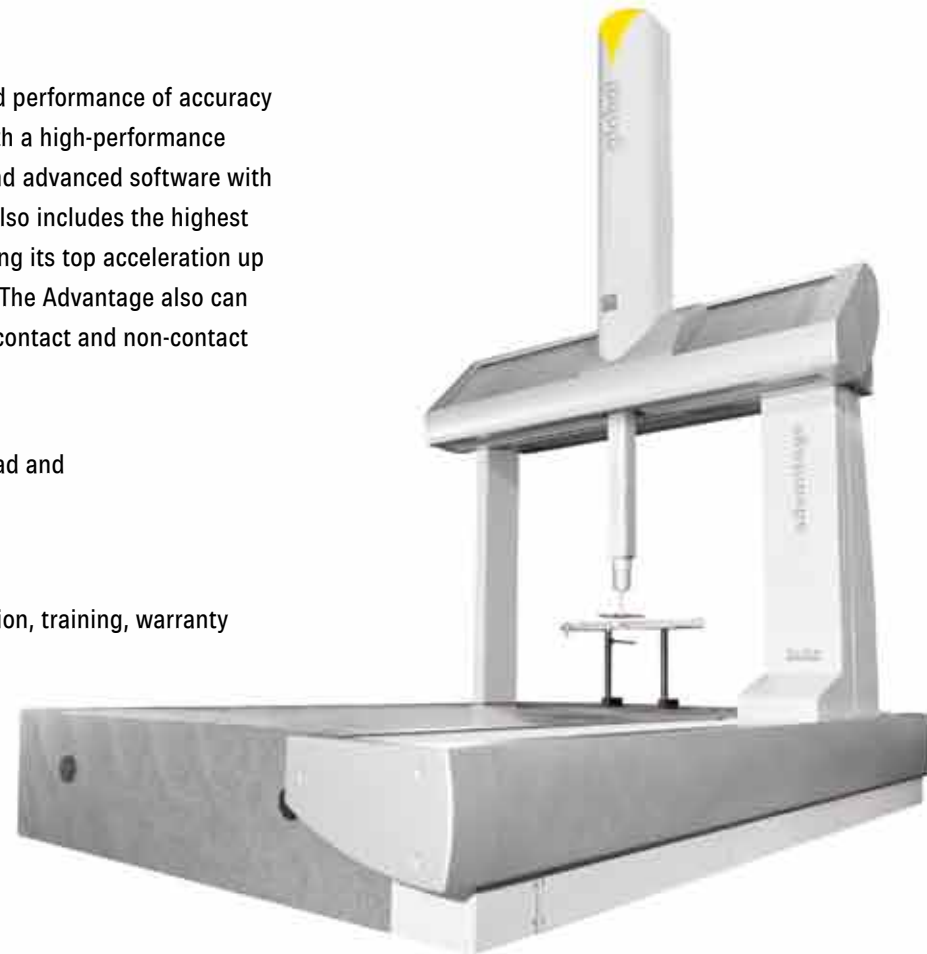

Big Advantages

Larger models of the Advantage line are available with measuring envelopes between 1,500mm x 2,600mm x 1,400mm and 2,000mm x 4,000mm x 1,500mm. These special systems offer the advanced performance features found in smaller Advantage machines.

Reference Xi

Designed specifically for high-accuracy scanning and featuring an advanced B4 controller and scanning algorithms, the Global Reference Xi provides the highest accuracy specifications in the Global line.

Standard Package

Probe: LSP-X3c or LSP-X5
Software: PC-DMIS CAD++
Control: B4 scanning controller
Accessories: Computer package, desk, installation, training, warranty
Options: Upgraded probes and QUINDOS software



Shop Floor

Designed to operate in harsh shop-floor environments and thermal conditions at high accuracy levels. Bellows and covers protect the machine from dust and airborne particles, while thermal sensors, advanced structural thermal compensation algorithms, and scales with a certified coefficient of thermal expansion provide exceptional thermal performance.

Standard Package

Probe: TESASTAR-sm motorized probe head and TESASTAR-mp touch trigger probe
Software: PC-DMIS CAD
Control: DC240C or DC800 controllers
Accessories: Computer package, desk, installation, training, warranty
Options: Upgraded probes and software

Extra

Global Extra CMMs are ideal for measuring large workpieces on the shop floor. With the Extra, you get the flexibility and performance of the Global design, with a measuring envelope that rivals many gantry machines—but without the special foundation a gantry CMM requires. The Extra model features:

- High accuracy and throughput compared to similar size machines.
- Large moving bridge architecture and X and Y bellows covers specifically designed to excel in harsh shop floor environments.
- Structural thermal compensation using advanced ACTIV algorithms with input from temperature sensors throughout the measurement volume.
- Extended thermal performance of 15-30°C (59-86°F) with allowed daily temperature changes of 10°C (50°F).
- Z-axis ram constructed of sintered silicon carbide to resist thermal effects.
- Four sizes ranging from 2,000mm x 3,300mm x 1,500mm to 2,000mm x 4,000mm x 1,800mm.

Standard Package

Probe: TesaStar-sm motorized probe head and TesaStar mp touch trigger probe
Software: PC-DMIS CAD++
Control: B3C-LC
Accessories: Computer package, desk, installation, training, warranty
Options: Upgraded probes and software



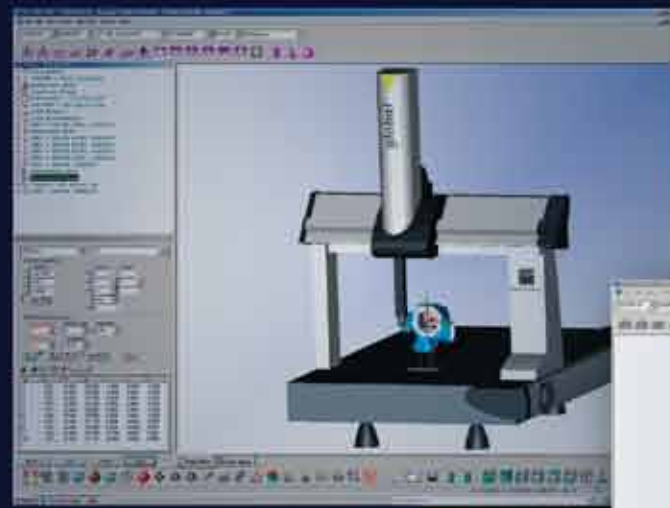

PC-DMIS software takes full advantage of Global scanning capability. In the example shown, the machined flange surface is being scanned for flatness; PC-DMIS allows for the specification of scan paths, shown as the yellow curvilinear line below.

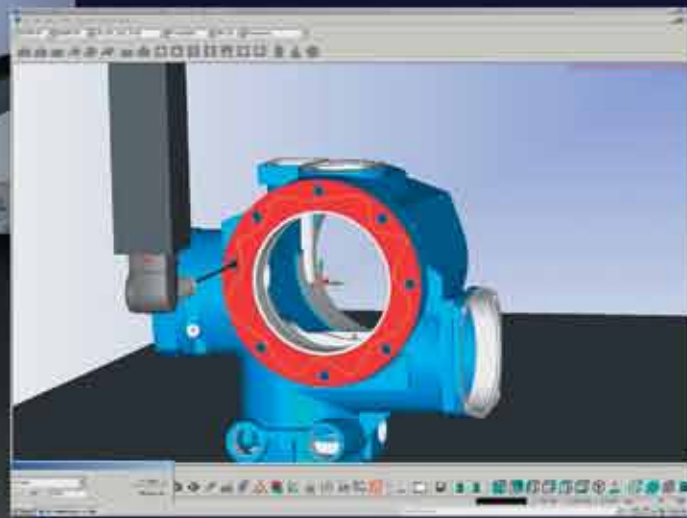

Global scanning

Complete multi-sensor capability

CMM users choose scanning technology to gather large amounts of data quickly. In many cases, scanning will yield higher quality results in less time than the traditional touch-trigger method. For many types of parts, collecting greater quantities of data decreases measurement uncertainty and improves the repeatability of the measuring process, resulting in greater confidence in the results. With unsurpassed positioning accuracy, reliability and ease of use, Global CMMs are the ideal platform for contact scanning, non-contact laser scanning and non-contact vision sensors.

This means that a Global CMM is the perfect tool for 3D visualization and inspection—the data gathered by scanning sensors are instrumental in analyzing all kinds of material surfaces, complex geometries and features, precise edge contours and more. Point clouds generated from scanning can even provide the data necessary for reverse engineering and prototype modelling.

Global scanning technology

- New Adaptive Scanning technology makes programming scanned features as easy as programming point-to-point measurements.
- Variable High Speed Scanning (VHSS) motion control algorithms are fundamental to Global CMM scanning capability. VHSS algorithms dynamically manage probe speed and acceleration by constantly monitoring input variables such as surface curvature to optimize performance. This results in fast, smooth probe trajectories while maintaining surface contact at all times. In addition, VHSS allows variable point collection density during a single scan path. Variable point density dynamically allows a greater density of points to be taken in areas of high curvature, while collecting fewer points in areas where the surface doesn't change. This avoids generating unnecessarily large data sets for areas of minimal complexity.
- When scanning a predefined path, the controller's OBSERVER function creates a feedback loop between the motion control algorithms and the probe head. This reduces measuring uncertainty and cycle time by keeping the head closer to the part's nominal dimensions.
- Exclusive 3D VECTOR FORCE OPTIMIZATION (3D-VFO) ensures accurate probe compensation and improved data analysis in scanning applications. Collected data is compensated automatically in real time, for all force, drag, styli and weight change conditions. 3D-VFO means precise data with any probe configuration.

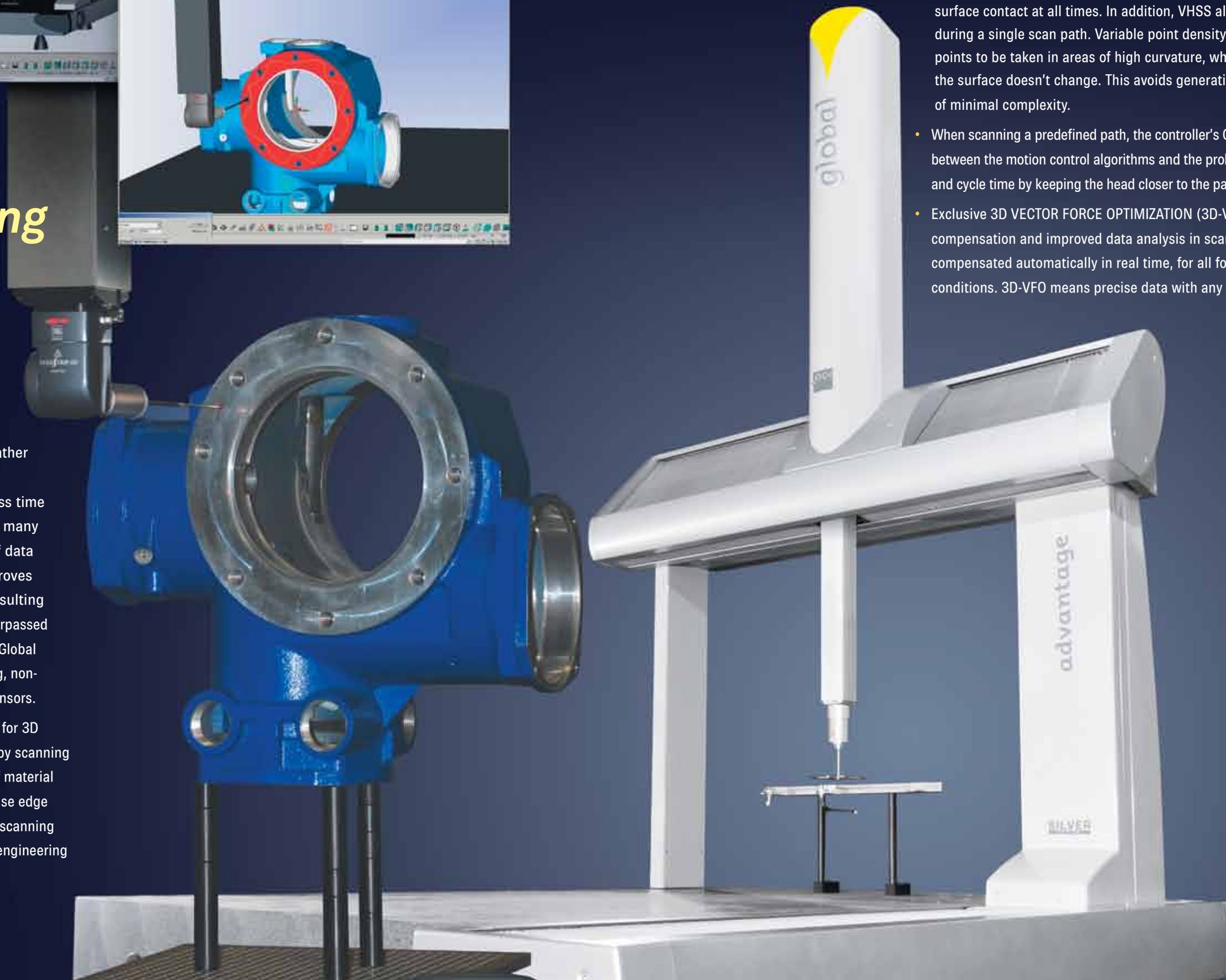



Leitz™ scanning probes – the accuracy standard

Leitz Scanning Probes (LSP) have been specifically designed to meet today's requirements for high-precision and high-throughput coordinate measuring machines. Fast and accurate, even with very long extensions, these scanning probes are ideal to verify high accuracy mechanical parts and complex geometries.

- True 3D Probing: Upon contact with the part surface, the probe automatically measures in the normal direction of the surface. Probing deflections are measured via high-resolution Linear Variable Differential Transducers (LVDT), allowing an accurate compensation of the probe bending, even when using long extensions. This capability reduces cosine errors and is vital when inspecting complex geometries such as gears, rotors and blades, since it ensures a higher measuring accuracy and throughput.
- No motors means no performance-robbing heat sources.
- Rugged construction provides reliable, maintenance-free operation.

LSP probes support all the standard probing modes such as single point probing, self-centering and continuous high speed scanning for fast and accurate form and profile measurements.



The LSP-X1 leverages world-renowned Leitz scanning technology in a compact continuous contact sensor.

Mounted on a TESASTAR-m or TESASTAR-sm indexable motorized probe head, the LSP-X1 features the ultimate in high-speed scanning measurement flexibility, with outstanding performance in both touch-trigger and scanning modes.

- LSP-X1 offers fast analog scanning suitable for the measurement of feature form, and touch-trigger capability for quick and accurate measurement of feature size and position.

- As a replacement for touch-trigger sensors, the LSP-X1 offers excellent measurement capability, reliability and accuracy.
- Optimized routines provide fast tip calibration.
- Cartesian Probe Technology guarantees probing a nominal point with much higher accuracy than other available methods; nominal probe trajectories are followed with maximum accuracy.
- State-of-the-art simulation tools eliminate accuracy-degrading mechanical effects.
- Large range of probe deflection (+/- 2mm) offers effective collision protection and better tracking of both pre-defined and undefined scan paths.
- LSP-X1s, LSP-X1m and LSP-X1h sensors provide optimized high-accuracy measurement over stylus lengths ranging from 20mm to 225mm. The LSP-X1s covers stylus lengths ranging from 20mm to 115mm with a single probe. The LSP-X1m is compatible with styli from 120mm to 200mm in length and LSP-X1h combines the performance of LSP-X1s and LSP-X1m probes, managing stylus lengths from 20 to 225mm in the vertical orientation (along the probe axis).
- Derived from LSP-X1 core technology, the LSP-X1c version is a cost-effective solution featuring a fixed dovetail quill mount. This probe head is optimized for stylus lengths up to 100mm. Up to four horizontal styli, each up to 50mm in length, can be mounted on a five-way stylus holder.

LSP-X3 and LSP-X5 offer unparalleled performance

Available on Performance (LSP-X3 only), Advantage and Reference Xi models, the fixed head LSP-X3 and LSP-X5 have defined high performance measurement using long styli, when high speed, accurate measurements deep within features are required. The LSP-X3 accommodates styli up to 360mm long and 150g mass. For even longer and heavier styli, the LSP-X5 extends the maximum stylus length and mass to 500mm and 500g, and features an additional anti-collision system for extra protection of the head.

Automatic tool changing with the Leitz Tool Rack allows styli changes within a measurement program without the need for re-calibration. Pneumatic clamping of the styli permits fast and accurate changing.



non-contact sensors

The **CMM-Ve high-resolution camera** gives you measurement performance that a tactile probe alone literally can't touch. With the CMM-Ve, your Global CMM will be ideally suited for a wide range of parts that require non-contact measurement:

- Printed circuit boards and other deposited or printed patterns.
- Small features that a touch-trigger stylus can't easily define.
- Precise edge contours.
- Soft or easily deformed parts.

With the CMM-Ve, you can easily change to your CMM's other sensors for complete multi-sensor inspection. CMM-Ve lets users measure features contained in an entire Field of View (FOV), or smaller Regions of Interest (ROI) within the FOV, such as hole diameters or edge positions. Software controlled, integrated LED illumination allows image optimization for each measurement. With one of the compatible automated changing racks, it's easy to switch sensors without changing set-ups.

Devour dimensional data with Hexagon Metrology's CMS 106 non-contact laser scanning.

Turn your Global CMM into the ideal platform for reverse engineering, point cloud to-CAD comparison, 3D visualization and non-contact inspection capability.

- The CMS 106 captures up to 30,000 points per second, comparing each point scanned to a CAD model in real-time. With so many scanned points, you get far more detailed views of both geometric and surface features than with a conventional touch-trigger probe. It's perfect for quick surface inspection of large, complex areas and generating point clouds for reverse engineering.
- Fully automatic and simple to use – no complicated settings or parameters to worry about.
- Unique "3x zoom" variable optical resolution - user selectable 25mm, 60mm or 120mm line length with up to 2,000 points per line. Perfect for quick surface inspection of large areas or measurement of small isolated features.
- Suitable for measuring almost any material, including machined, semi-finished, stamped, forged, cast, painted metals, sand cores, carbon fiber, plastics, clay, rubber, wood and ceramic.
- Fully compatible with several probe changers for multi-sensor measurement. Compatible with Renishaw ACR3, TesaStar-r rack or CU43 wrist tool-changer equipped with an optional warm-up post; additional optional parts for ACR3 and TesaStar-r in case of horizontal arm machine.
- The reverse engineering package includes options such as PC-DMIS Reshaper or Innovmetrics' PolyWorks®/Modeler™, a comprehensive software solution for creating accurate, smooth polygonal models and NURBS surfaces from high-density point clouds.

TESASTAR probes

Hexagon Metrology offers a complete range of Swiss-made TESASTAR probes and accessories ideal for your Global CMM.

TESA engineers have designed a complete group of components for precise coordinate measurement, including styli, extensions and accessories.

The entry-level probe in the TESASTAR family, the **TESASTAR Probe** head is fitted with a touch probe with adjustable trigger force. The compact TESASTAR is especially convenient for small CMMs. It can be manually swiveled to an infinite number of positions.

TESASTAR-i features repeatable indexing coupled with a high-precision integrated touch probe. The indexing capability in 15° increments in both axes allows the stylus to swivel through 168 positions without the need for recalibration. The A and B positions are clearly indicated in separate dials on the probe, so that the precise angle can be viewed at a glance. Indexing between positions is an easy, one-handed operation; tactile and visual feedback lets you know when the probe is ready to measure.

TESASTAR-m and -sm are motorized articulating probe heads capable of indexing in 5° increments, +180° to -180° in revolution, and +90° to -115° in pitch. This translates to a total of 2,952 possible positions, including a unique "table-hugging" 90° horizontal position possible due to the indexing arm's asymmetrical shape. The head also is available in a 7.5° increment version for maximum compatibility with third-party products. These heads feature high-speed indexing, with faster index changes than similar products. Robust aluminum construction and rugged design permits extension rods with lengths up to 300mm. The TESA kinematic joint connection accepts multi-wired probes, or, coupled with an M8 adaptor can be used with TESA touch-trigger probes as well as other probe brands. The new TESASTAR-sm features a quill mount providing an increase in the useable Z-axis length.

The **TESASTAR-p** is an M8 threaded 5-way touch probe. There are four variations available, providing variable trigger force from 0.05 N to 0.10 N. The **TESASTAR-mp** variant features a magnetic connection between the probe body and probe module; the **TESASTAR-rp** has extended overtravel designed for rugged environments.

TESASTAR-r Probe Autochange Rack, coupled with the TESASTAR-m motorized probe head is a fully automatic active probe changing solution, which accommodates multiple probe types, with or without extensions. The rack also is fully modular, and can be configured with three to nine changing ports, or any number in between. You don't have to buy ports you don't need, and you can add one or more ports later should your needs change. The **TESASTAR-pr** Autochange Rack accepts up to six TESASTAR-mp modules for maximum flexibility. **TESA Stylus Kits** provide ruby-tipped styli for general measurement applications, and are compatible with standard probes from any manufacturer.

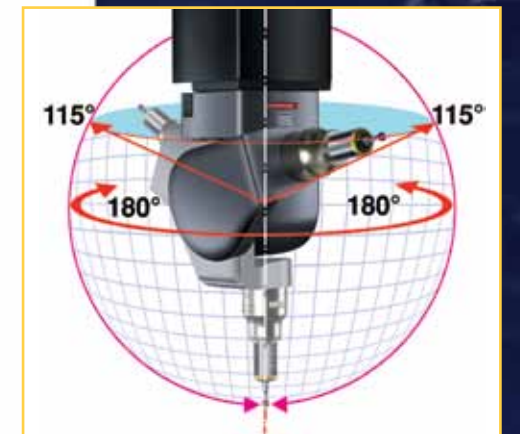
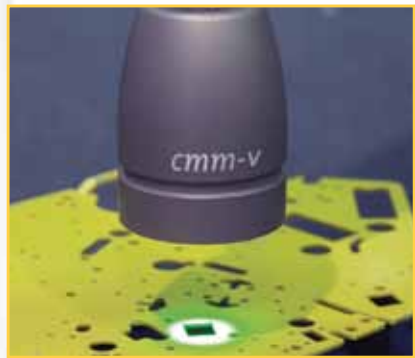

PC-DMIS is the world's most powerful and widely used dimensional inspection software. Available in multiple versions and with a number of options packages, it provides the most comprehensive solution to any type of metrology application.

PC-DMIS® PRO is the baseline version of PC-DMIS, offering a full range of measurement, evaluation and reporting functions. It's ideal for customers who don't use CAD in their inspection process. For the novice, PC-DMIS PRO includes a set of easy-to-use "Quick Start" routines. These automate many of the basic metrology functions to help new users get up and running as quickly as possible. More experienced users can measure even the most challenging parts with PC-DMIS PRO by taking advantage of its complete set of programming tools, graphical and textual reporting capabilities, and links to third-party software. With PC-DMIS PRO, you can:

- Make quick checks or program complex parts using a powerful, flexible GUI.
- Analyze measurement data with a rich selection of PTB certified measurement algorithms.
- Report inspection results using built-in templates or customize your own hyper-reports.
- Develop tailor-made, high-level language routines.
- Upgrade directly to PC-DMIS CAD or PC-DMIS CAD++.
- Link to CAD via optional IGES and DMIS pre- and post-processors.
- Configure the toolbars and menus according to specific needs and preferences.

PC-DMIS® CAD adds the ability to import CAD files. PC-DMIS CAD works with CAD models of all types, from basic 2.5D wireframes to the most complex solid models. With its easy-to-use GUI, accurate machine modeling and new, built-in QuikFixture™ module, PC-DMIS CAD makes short work of developing, testing and debugging inspection programs both on-machine and off-line. PC-DMIS CAD imports and exports CAD information in most internationally accepted formats. Optional modules are available for even tighter integration of CAD and CMM systems. In addition to the capabilities of PC-DMIS PRO, PC-DMIS CAD allows users to:

- Link to CAD bi-directionally using built-in DES, DMIS, DWG, DXF, IGES, STEP, STL, VDAFS and XYZJK translators.
- Easily work with even the largest CAD files with an improved graphics engine employing the latest technology.
 - Change probe paths, add and delete hits, and modify measurement parameters with the click of a mouse.
 - Use new graphics-based tools to manage part programs; take fine control over variables such as model lighting, transparency and texturing; create cut planes that give direct access to areas of interest and highlight surfaces using Mouse Over Highlighting (MOHL).
 - Operate directly on native CAD models using a Direct CAD Interface™ (DCI) technology or translate into and out of the native CAD format using a Direct CAD Translator™ (DCT).
 - Manipulate CAD models using tools for: mirroring, adding layers, removing, hiding and changing entities and adding grids.
 - Easily reverse-engineer parts.

PC-DMIS® CAD++ adds scanning and thin-walled part measuring routines. PC-DMIS CAD++ incorporates scanning and digitizing functions that allow fast and efficient measurement of complex shapes such as turbine blades, dies, molds, sheet metal components and other curved shapes. In addition, PC-DMIS CAD++ has a complete suite of thin-walled (sheet metal) functions. With strong roots in the automotive industry, these routines make inspecting these difficult parts fast and trouble free.

Along with all the capabilities of PC-DMIS PRO and PC-DMIS CAD, PC-DMIS CAD++ lets you:

- Quickly define scan paths and extract nominal values and vectors.
- Scan and measure contoured and sheet metal parts using Touch-Trigger Probes, Analog Probes and Laser Probes.
- Use any of a full range of scanning methods.
- Easily measure thin-walled features using pre-defined routines.
- Automatically scan and reverse engineer unknown surfaces and features.
- Effectively use your manual CMMs to scan both thin-walled and contoured parts.
- Dynamically compensate for variations in sheet metal parts using a wide variety of specialized functions.
- Effortlessly align the most complex parts using iterative alignments.
- Analyze your results in either 2D or 3D.

PC-DMIS® Vision brings the power of PC-DMIS to the job of programming and inspecting parts on Global CMMs equipped with a vision sensor. Using PC-DMIS Vision CAD-based inspection software, you can:

- Work directly on a 3D CAD model to develop, debug and edit vision inspection programs. Improve part programming throughput by up to 75%.
- Extract information directly from the model without programmer interaction. Eliminate manual data entry and evaluate measurement results directly against the CAD definitions.
- Develop programs off-line with an optional module that simulates all aspects of the measurement process. Switch between the CAD view and a simulated camera view that accurately depicts what the camera will see as it measures the part.
- Import models and export measurement results in a wide range of industry standard and vendor specific CAD formats.

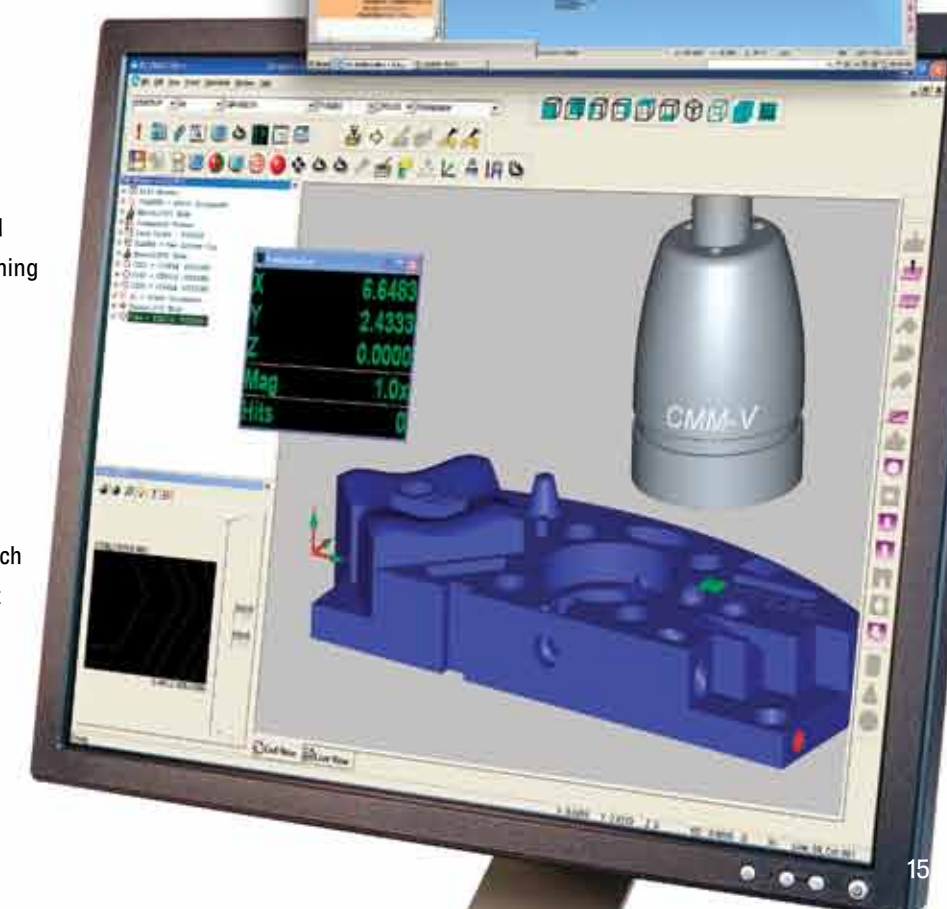
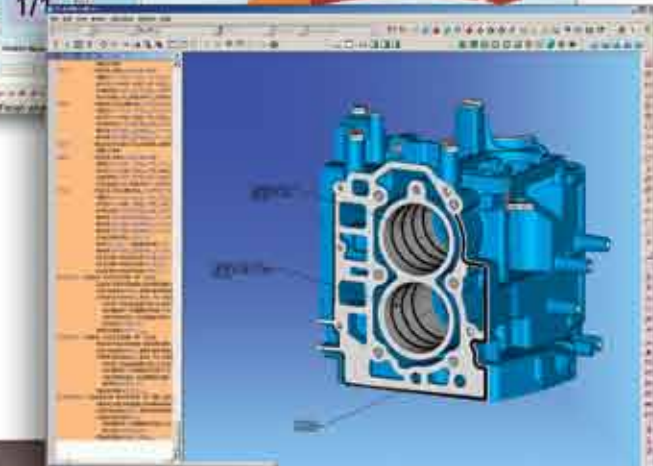
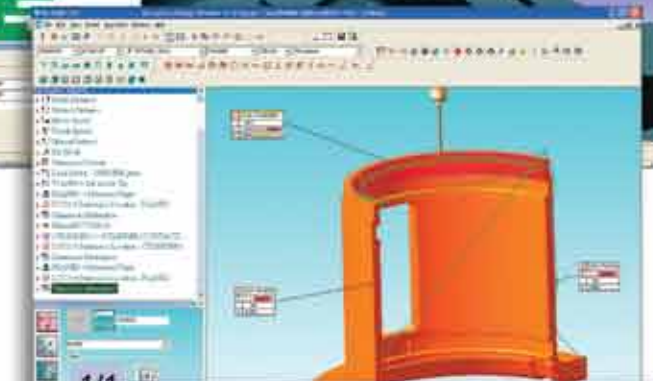
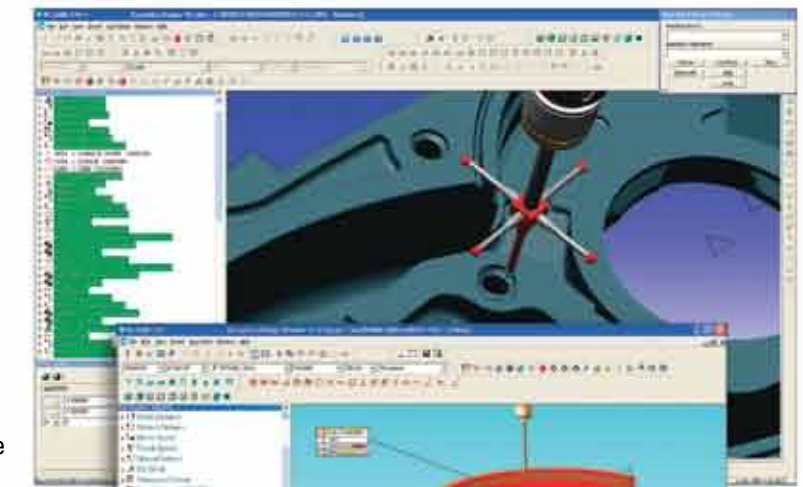



The Brown & Sharpe brand name has been synonymous with quality for more than 150 years. Once a stand-alone company, today Brown & Sharpe is a flagship brand of the Hexagon Metrology group. Brown & Sharpe brand Coordinate Measuring Machines (CMMs), optical measuring systems, 1D, 2D and 3D benchtop measuring machines and precision hand tools represent the highest quality in design, construction and performance.

Brown & Sharpe, a brand of Hexagon Metrology, Inc.
 250 Circuit Drive, North Kingstown, RI 02852 USA
 Tel: (800) 274-9433 • Fax: (401) 886-272
www.brownandsharpe.com • www.HexagonMetrology.us

United States

Elgin, IL

Tel: (847) 931-0100
 Fax: (847) 931-1979

Miamisburg, OH

Tel: (937) 247-0425
 Fax: (937) 247-0426

Lake Forest, CA

Tel: (800) 955-5200
 Fax: (949) 916-4499

Kent, WA

Tel: (253) 872-2443
 Fax: (253) 872-2579

Wixom, MI

Tel: (248) 449-9400
 Fax: (248) 449-7438

Nashville, TN

Tel: (615) 331-0800
 Fax: (615) 331-0875

Huntersville, NC

Tel: (704) 947-1250
 Fax: (704) 947-1277

Irving, TX

Tel: (972) 506-8359
 Fax: (972) 506-9162

Mexico

Monterrey, Mexico,

Tel: [+52] (81) 13 67 08 00
 Fax: [+52] (81) 13 67 08 01

For other countries please consult:
www.HexagonMetrology.com

© Hexagon Metrology, Inc., 2012 all rights reserved.
 All specifications listed in this brochure are subject to change without notice.
 For use in North America market area.
 Printed in USA - 5/12
 #990131

ISO 9001, 14001, 18001, and 17025 certified.

