



KOOL - STRIDE[®] "WITH KOOL- FOLD"[™]
Model No. KF-SSN (SPECIAL USE)

OWNER'S MANUAL & SET UP INSTRUCTIONS

Please read & save all instructions contained in this booklet
Examine all carton contents and wrappings carefully before assembly.

READY, SET...GO![®]

Family fun is yours in a snap with your new, snug, sturdy and smooth-riding jogging stroller for children by KOOL-STOP INTERNATIONAL INC. Your Jogging Stroller is loaded with superior comfort and safety features, assembles for action in a few easy steps and folds down into a lightweight, portable package for toting.

Your New KOOL-STRIDE[®] Jogging Stroller includes these features:

- Folds down, assembles quickly and easily in 1 minute or less.
- Removable push button alloy wheels with precision bearings and stainless steel spokes.
- Removable seat cushion for added comfort.
- Sunshade that protects your child from heat, UV rays, and an extra large PEEK-A-BOO window built into a multiple position canopy.
- Extra large lower storage basket.

THINK SAFE AND BE SAFE!

- Avoid city streets, heavy traffic and dangerous situations.
- Always use the wrist retention strap.
- Never roller-skate while pushing your stroller.
- Never leave your stroller unattended when occupied even when parking brakes are engaged.

KOOL-STRIDE[®] all terrain strollers
are patented and protected by the
following U.S. And foreign patent numbers:
D419,133 D382,234 D371,094 D418,780
5,536,033 5,695,212 5,934,754 4,953,880

FURTHER U.S. AND FOREIGN PATENTS PENDING



SETUP INSTRUCTIONS (Fabric and wheels not shown for clarity)

- STEP 1. Remove from carton and set wheels aside.
Lay stroller on a flat surface, as shown in FIG. 1.
- STEP 2. From rear of stroller, take hold of the stroller by the handle bar ratchets and pull toward you until frame is extended giving a final quick tug so that locking buttons snap in place, as shown in Fig. 2 & 2-A * BE SURE TO CHECK THAT BUTTONS ARE LOCKED BY CHECKING THE SLIDING HINGE AND STOPPING COLLAR ARE BUTTED TOGETHER AS SHOWN IN FIG. 2-B
- STEP 3. Release the handle bar clamps to unfold the handle bar and adjust handle bar to desired position, as shown in FIG. 3, then reclose the clamps.
- STEP 4. Now deploy the wrist retention strap from axle tube and connect to Velcro[®] tab on the handle. This is to keep strap out of the way when running and will break away and stop stroller if needed. Never use stroller without the wrist strap properly secured to your wrist. (see FIG. 3)

FOLDING INSTRUCTIONS (Fabric and wheels not shown for clarity)

- To fold, open the cam levers on both sides of the adjustable handle and fold the extended handle all the way underneath until notch marks in ratchets are aligned, then reclose the cams. (Shown in fig 2-A)
- STEP 1. Depress and hold locking buttons shown in figure 2.-B on both sides and then push forward until stroller is completely flat as shown in FIG. 1.
- STEP 2. *NOTE; STROLLER MAY BE FOLDED WITH OR WITHOUT WHEELS ATTACHED.

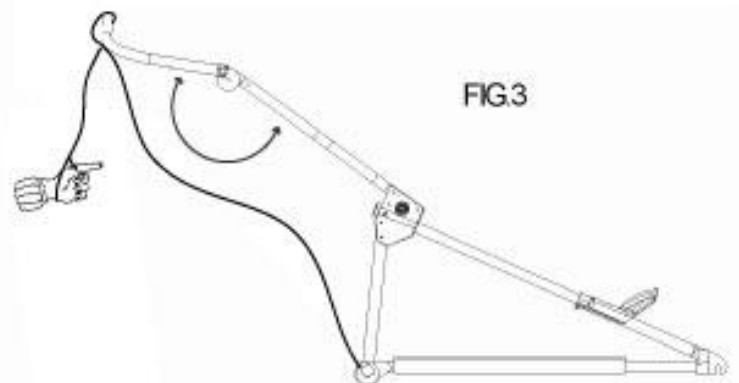
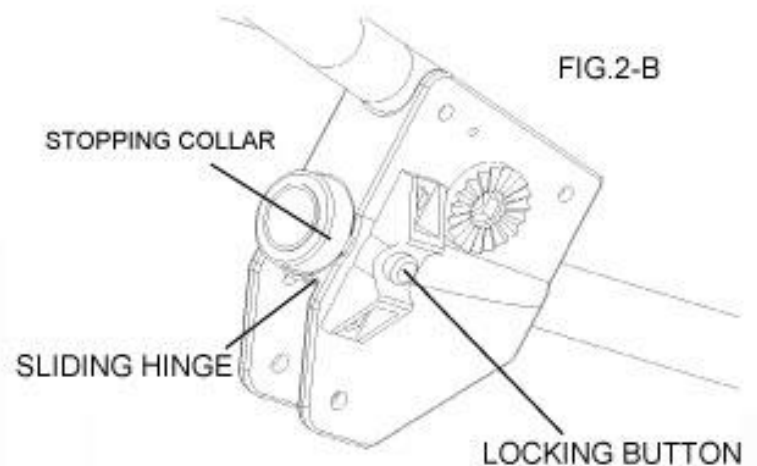
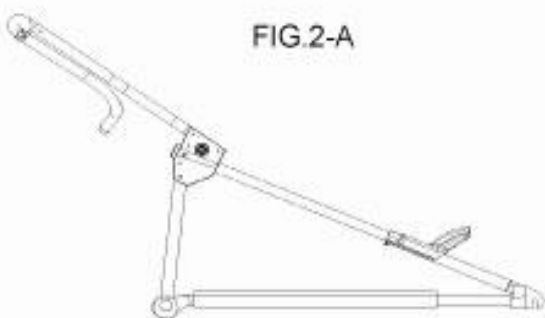
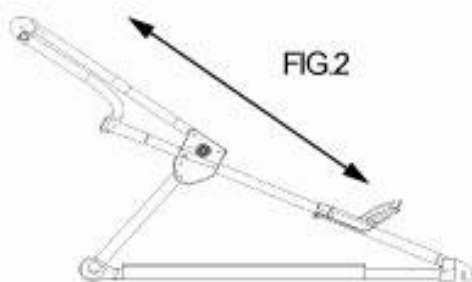
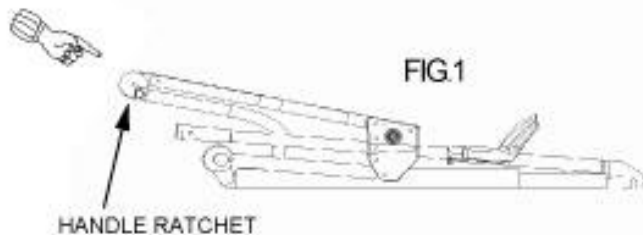



SECURE THE QUICK RELEASE (Q/R) REAR WHEELS FIG.4 -5 & 5A

- STEP 1. Insert the wheel axle into the wheel bearing of the wheel (You must depress button) FIG 1.
- STEP 2. With button depressed, slide the wheel and axle into the axle end and push in until it stops. FIG.2.
- STEP 3. Release the button and inspect that the button is popped out. (Shown in fig 5A)

NOTE: PULL ON THE WHEEL WITH FAIR PRESSURE TO CHECK SECURENESS OF THE WHEEL. IF THE WHEEL PULLS OUT THEN THE BUTTON IS NOT LOCKED. REPEAT STEP 2&3.

SECURING THE FRONT WHEEL (FIG.6)

- STEP 1. Open cam lever D and unscrew knob T until almost off the end of the skewer.
- STEP 2. Slide the wheel & axle XX into both fork ends Q .
- STEP 3. Clamp down the wheel axle to the fork ends by tightening knob T until snug and then closing cam lever D .(You should feel resistance if correct.) Give a good tug to check that wheel is secure.

ADJUSTING FRONT WHEEL Q/R AXLE

You may need to adjust the clamping tension on the wheel AA to secure it in place. Hold adjusting knob T and turn cam lever D clockwise a turn or so and clamp lever D down to check tension. Repeat if necessary or back tension off by reversing tensioning procedure.

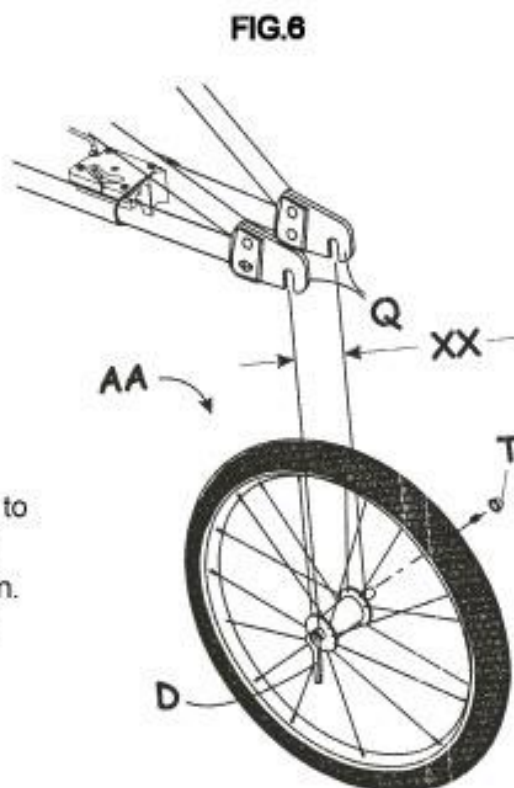

SEAT BELT OPERATION

- STEP 1. RELEASE THE MAIN BUCKLE AND LAY STRAPS TO THE SIDES AS SHOWN IN PHOTO A. & B.
- STEP 2. SEAT PASSENGER INTO SEAT AND FIT SHOULDER STRAPS, LAP BELTS, AND GROIN STRAP AROUND PASSENGER.
- STEP 3. SLIDE GROIN STRAP OVER THE MAIN BUCKLE AND RE CLOSE AS SHOWN IN PHOTO C. & D.
- STEP 4. CHECK SECURENESS OF THE BUCKLE AS SHOWN IN PHOTO E.
- STEP 5. IF NEEDED, THE SHOULDER STRAPS CAN BE ADJUSTED TO FIT TALLER OCCUPANTS BY REMOVING THEM FROM THE MAIN BUCKLE AND THEN PULLED OUT OF THE FIRST OR EVEN SECOND HOLD DOWNS SHOWN IN PHOTO F.

PHOTO A.



PHOTO B.



PHOTO C.



PHOTO D.



PHOTO E.



PHOTO F.



CANOPY OPERATION

TO DEPLOY CANOPY SIMPLY TAKE HOLD OF THE EDGE AND PULL FOWARD UNTIL TAUGHT AS SHOWN IN PHOTO G. & H. TO DEPLOY THE INTEGRATED SUN SHIELD, REACH UNDERNEATH AND PULL OUT THE FLEXIBLE EDGE UNTIL IT IS TAUGHT AS SHOWN IN PHOTO I. & J.

PHOTO G.



PHOTO I.



PHOTO H.

PHOTO J.



THE SIDE FLAPS MAY BE ROLLED UP AND ATTACHED TO THE TABS AS SHOWN IN PHOTO K. THIS WILL PROVIDE FURTHER VENTILATION WHEN DESIRED.

PHOTO K.



PARKING BRAKE OPERATION (FIG. 15 & 16)

Your KOOL-STRIDE[®] is equipped with two parking brakes. The brake lever on the handle can be used manually to slow the stroller down while jogging. The brake lever on the handle is also equipped with a locking mechanism that acts as a parking brake. To lock the brake in the parking position, as shown in FIG. 16, hold the brake handle down to apply the brake. Hold the locking button HH down while releasing the handle. To release the parking brake. Depress the brake handle, and the locking button will release itself.

NOTE: PROPER TIRE INFLATION IS NEEDED FOR PROPER "P" BRAKE OPERATION (30-60 PSI.)

CAUTION:

NEVER LEAVE YOUR CHILD UNATTENDED IN THE STROLLER EVEN WHEN PARKING BRAKES ARE ENGAGED .

ALWAYS USE THE REAR WHEEL RETENTION STRAP .
SECONDARY PARKING BRAKE

A secondary parking brake is strap JJ located on the side of the stroller to prevent the wheel from rolling.

Thread strap JJ through the spokes and wrap it around the wheel. Secure clip KK as shown in FIG. 17

WARNING!

Always clip strap JJ around upright tube C, as shown in Figure 18 when not in use. The strap can get tangled in the spokes and may damage the wheel.

While both parking brake systems are made of quality materials and will hold the KOOL-STRIDE[®] steady in the parked position, you should always exercise caution when putting a child in the stroller. Don't attempt to put a child in the stroller (or expect the stroller to hold) on a hill.

STORAGE AND TOTING INSTRUCTUONS

- *Leave seat in place, in upright position
- *Reverse procedures described on pages 2, 3 & 4.
- *Nest rear wheels so that the axles face each other.
- *Keep sharp objects away from fabric.
- *FOR BEST STROLLER PROTECTION AND STORAGE, IT IS RECOMMENDED TO USE THE TRAVEL-CARRY BAG AVAILABLE FROM YOUR RETAILER OR KOOL-STOP.[®]

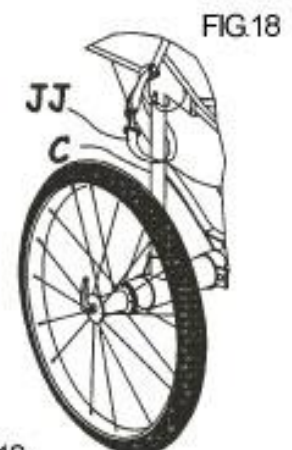
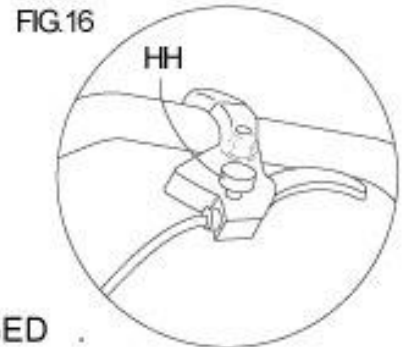
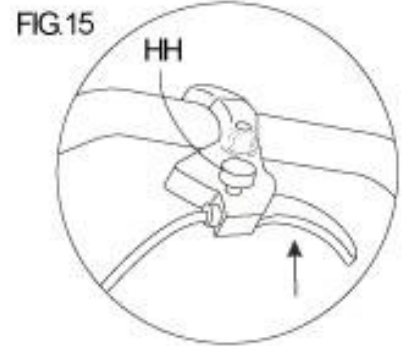

DESCRIPTION	PART NO.
1. FRONT WHEEL ASSEMBLY	HW344
2. REAR WHEEL ASSEMBLY	HW345
3. AXLE TUBE	AL119
4. UPPER SIDE TUBE	AL116
5. HANDLE TUBE	AL115
6. LOWER SIDE TUBE	AL118
7. LOWER EXTRUSION	AL117
8. UPRIGHT TUBES	AL106
9. AXLE ENDS	PL234*
10. AXLE TUBE TO UPRIGHT CON.	PL209
11. BOTTOM AXLE CONNECTOR	PL202
12. FRONT WHEEL SKEWER	J1-1016*
13. PUSH BUTTON AXLE	HW346
14. P BRAKE ASSEMBLY	KSPB
15. FORK TIP LEFT	PL200
16. FORK TIP RIGHT	PL201
17. LOCK BODY LEFT	PL214
18. LOCK BODY RIGHT	PL215
19. HANDLE RATCHET "A" LEFT	PL210
20. HANDLE RATCHET "B" RIGHT	PL211
21. SEAT ASSEMBLY	FB520
22. SEAT PAD*	FB524*
23. CANOPY	FB521
24. FOAM GRIP LONG "RIGHT"	PL232
25. FOAM GRIP SHORT "LEFT"	PL232
26. SAFETY STRAP "LEASH"	FB505
27. LEASH TAB	FB506
28. FOOT PLATE	PL207
29. BRAKE LEVER ASSEMBLY	J1-1100
30. BRAKE CABLE ASSEMBLY	HW335/336

DESCRIPTION	PART NO.
31. LOWER BASKET	FB522
32. PARKING BRAKE STRAP*	FB504
33. UPPER OVAL TUBES	AL106
34. CANOPY WIRE FRONT*	HW352*
35. CANOPY WIRE REAR*	HW353*
36. FIVE POINT BUCKLE	5LT32
37. CANOPY RATCHET*	PL228*
38. CANOPY RATCHET SPRING*	HW341*
39. CANOPY WASHER*	HW340*
40. SEAT PAD	FB524*
42. LOWER BASKET WIRE	HW354
43. FOLDING BUTTON HOLDER*	PL206*
44. FOLDING BUTTON "ALUM."*	AL100*
45. STRAIGHT EYE END LONG*	PL205*
46. STRAIGHT EYE END SHORT*	PL204*
47. SHOULDER STRAP ADJ.	N/A
48. HANDLE RATCHET CAM*	HW321*
49. HANDLE RATCHET SPRING*	HW323*
50. HANDLE RATCHET NUT*	HW301*
51. CANOPY RATCHET NUT*	HW301*
52. CANOPY RATCHET BOLT*	HW330*

* ITEMS NOT ILLUSTRATED

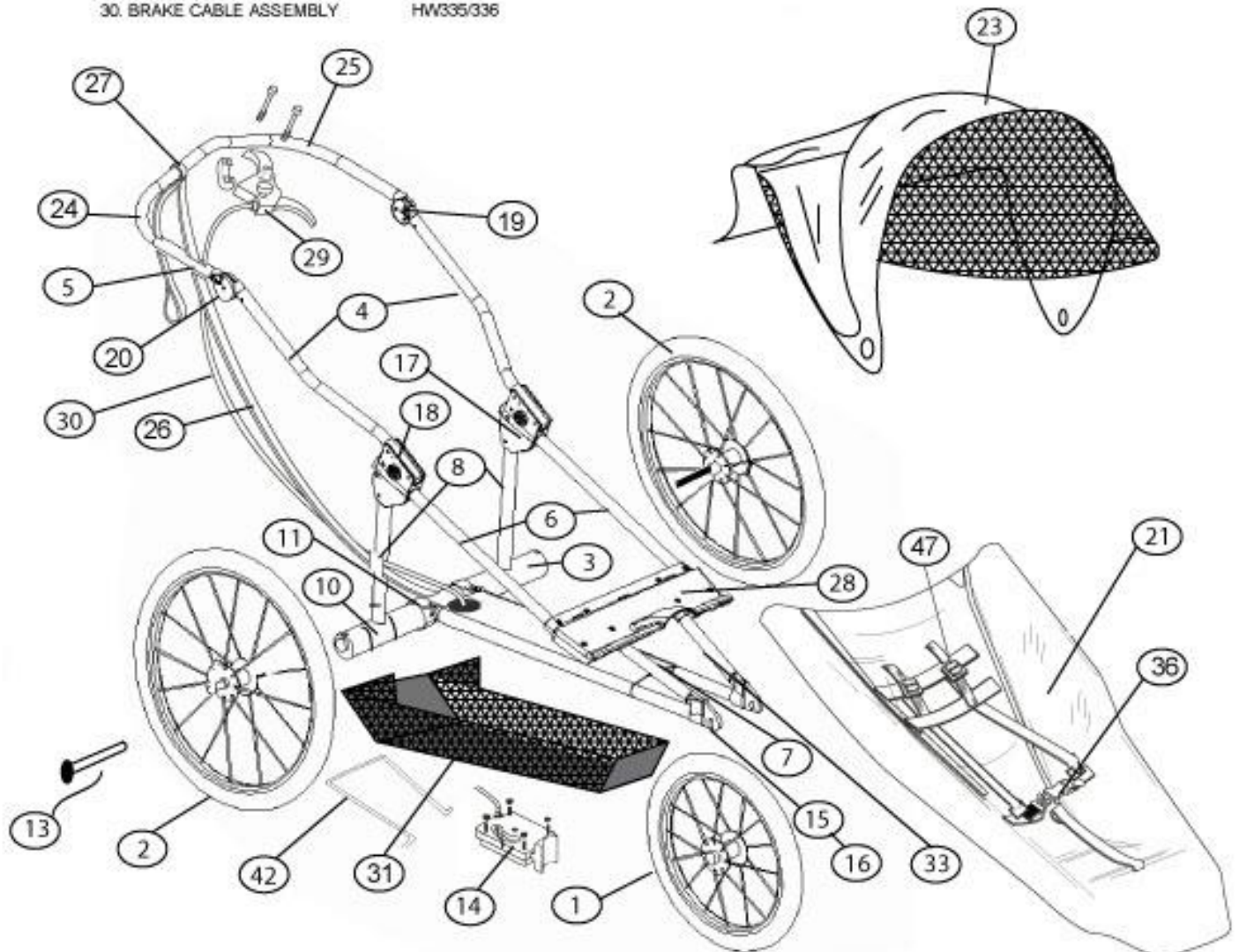

CAUTION!

(MAXIMUM WEIGHT LIMIT IS 150 LBS.) Never hang items from the handle, it can cause the stroller to tip backwards and injure the passenger!

IMPORTANT... Although a helmet for the passenger is not required, it is a good idea to put a helmet on the passenger when jogging with a stroller.

* MANUFACTURER'S SUGGESTED RETAIL PRICES SUBJECT TO CHANGE WITHOUT NOTICE.

KOOL-STRIDE® 3 YEAR LIMITED WARRANTY

KOOL STOP INTERNATIONAL, INC. warrants this product to be free of defects in workmanship and material for 3 years (with the exception of all fabric components, which shall be warranted for a period of one year). Under normal use and service following date of purchase and delivery to the original customer, the warranty does not cover wheels and tires.

This warranty will not apply to damages arising from neglect, accidental or intentional damage, institutional or commercial use, or misuse of the product.

Repairs or replacement under this warranty shall be made by KOOL STOP INTERNATIONAL, INC. or through an authorized KOOL STOP INTERNATIONAL, INC. dealer without charge to the customer.

If the dealer or factory representative finds return necessary, packing and shipping cost to the factory will be prepaid by the customer. KOOL STOP INTERNATIONAL, INC. will, at its sole option, repair or replace the product and ship it (or one of equivalent type and quality if exact replacement is unavailable) to the dealer authorizing the return.

Expressly excluded by this warranty is liability for consequential property or commercial damages. THIS IS A LIMITED WARRANTY.

Information in this manual is subject to change without notice. CHECK FOR UPDATES AT: "WWW.KOOLSTOP.COM"

©2002 KOOL-STOP INTERNATIONAL, INC. All rights reserved. No part of this OWNER'S MANUAL AND ASSEMBLY INSTRUCTIONS publication may be reproduced, transmitted, transcribed, stored in a retrieval system, or translated into any languages in any form, by any means, without written permission by KOOL STOP INTERNATIONAL, INC.

Designed and manufactured By:
KOOL-STOP INTERNATIONAL, INC.
5700 Willow Ln.
Lake Oswego, OR. 97035

THINK SAFE AND BE SAFE!

WWW.KOOLSTOP.COM

MAINTENANCE AND CLEANING SPECIFICATIONS FOR KOOL-STOP® STROLLERS

CLEANING (ENTIRE STROLLER)

For general cleaning you may simply wash your stroller as you would an automobile. For instance, scrubbing down the entire stroller with a scrub brush and non bleach dish soap & water would be sufficient to clean normal sediments, dust and dirt, etc. Then rinse with fresh water (tap water from garden hose).

Wipe down frame parts and excess water from fabric with a clean towel then allow to dry out of direct sunlight. This cleaning procedure should only be performed out side at temperatures at or above 60 degrees Fahrenheit in order for proper drying to occur.

AFTER CLEANING ALWAYS PERFORM LUBRICATION PROCEDURES LISTED UNDER: "LUBRICATION & PREVENTATIVE MAINTENANCE" SECTION

CLEANING (FABRIC REMOVED)

Remove canopy by extracting both canopy ratchet screws located on the sides of the stroller on the sliding hinge portion of the stroller (see fig. 2-b page 4) or locate on the exploded view on parts list page. Be sure to note the order in which the hardware is assembled and always place removed hardware in a container or plastic bag as not to lose any parts. There is a nut recessed in the back side of the hinge that the ratchet screw threads into, be sure to remove these as well when you remove the ratchet screws.

Now undo the Velcro® at the back of the canopy and remove the canopy. Remove metal wires from canopy and set canopy aside.

Remove all screws on seat fabric that hold any part of the fabric to the frame as well as all Velcro® straps. (once again, don't forget to note the locations and order in which they belong and keep together in a container). Once this has been performed the seat and canopy should be free of the frame.

Fabric may now be hand washed in cold water with non-bleach detergent and then hang dried. Resort back to procedures for cleaning entire stroller to clean remaining frame work and wheels

NEVER CLEAN STROLLER WITHOUT PERFORMING LUBRICATION PROCEDURES TO BE LISTED ON FOLLOWING PAGE. (10)

MAINTENANCE AND CLEANING CONTINUED

LUBRICATION & PREVENTATIVE MAINTENANCE

Every 60 days or immediately after cleaning, the stroller should be lubricated as follows:

With a light film greaseless lubricant, spray all metal surfaces of the wheels and allow to sit for a few minutes. (We recommend using LPS 1 You can find this lubricant at your local hardware & automotive stores.)

After letting the wheels sit, wipe clean with a cloth. This will leave a thin film as a protective layer on the metal parts of the wheels. This will also give a nice glow to the rims.

All other parts on the stroller are made of either aluminum or stainless steel and do not require lubrication.

NOTE: EVEN STROLLERS WITH THE ALLOY WHEELS SHOULD BE MAINTAINED IN THIS MANNER.(ALLOY WON'T RUST BUT IT WILL OXIDIZE.)

TIRE PRESSURES

Tire pressures should be checked periodically because they may change in time and with changes in the weather. Performance and ride are also effected by tire pressure.(see chart)

	RECOMMENDED PRESSURES		
FRONT	20 - 40 PSI	REAR	40 - 65 PSI
ADJUST FOR PREFERRED RIDE			
ALWAYS CHECK FOR ACTUAL MAXIMUM TIRE PRESSURE MARKED ON TIRE SIDEWALL			

PARKING BRAKE ADJUSTMENT

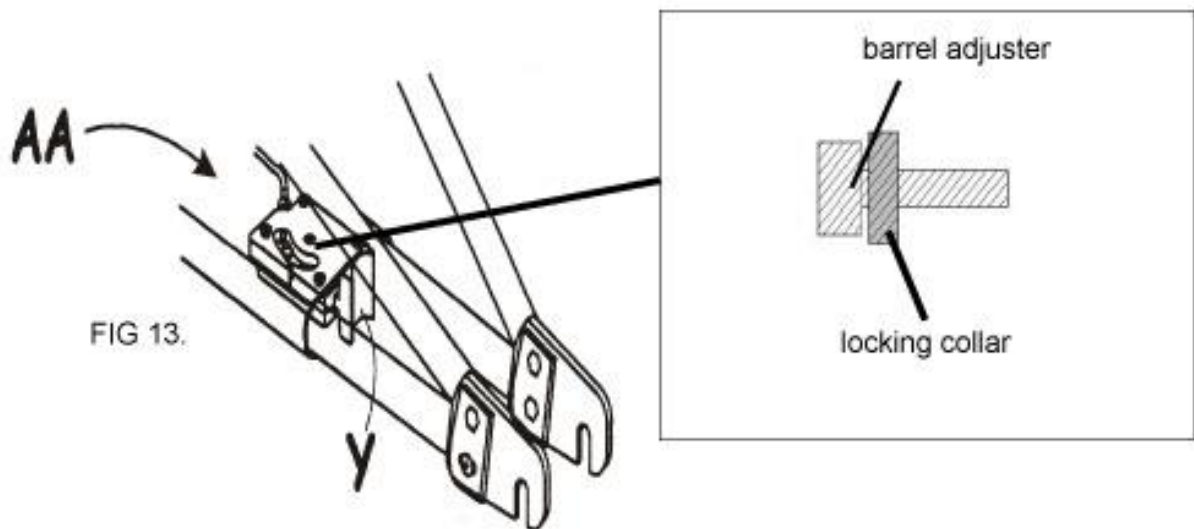

If needed, you can adjust the tension on the brake to be tighter as the cable may stretch over time. To do this turn the barrel adjuster AA counter clock wise until you achive good contact with the wheel when you depress the lever at the top of the stroller handle. Once adjustment is achieved, lock the barrel adj. in place by turning only the locking collar back in clockwise direction until it is tight against the p-brake Y. See FIG. 14 for detailed illustration.

FORK TIP ADJUSTMENT (FIG.8 & 9)

The fork tip adjustment is preset from the factory. However, if you notice the front wheel is not tracking correctly, you may need to adjust the front wheel for correct alignment. To adjust the front wheel alignment in linear position, loosen the screw (S) on the fork tip (K), and manually move the wheel to the desired position. You may need to roll the stroller back and forth to test the new setting. Tighten the adjustment screws when wheel is aligned.

NOTE:

To achieve proper wheel alignment, you may need to test roll the stroller several times.

