



 **LMI**  
MILTON ROY

# Metering Pumps

# Excellence through Versatility



*Liquid Metronics Incorporated has been providing quality products and service to the water treatment industry worldwide for over 25 years.*

*Leading the way in the metering pump industry, LMI introduced the first full line of electronic metering pumps and accessories. The breadth of LMI's product line extends from low-cost metering pumps for domestic potable water treatment to highly sophisticated custom designs for specific customer applications.*

*Today, LMI continues to shape the future of the industry by offering the next generation of our trademark yellow and black metering pumps, the LiquiPro™ Series. This series of electronic metering pumps offers simple installation and maintenance with its unique cartridge valve design, as well as quick and easy “hands free” priming three, four function and auto prime valves.*

*Utilizing superior designs and industry experience, as well as a state-of-the-art facility and highly trained service representatives, LMI offers Water Treatment Professionals the quality and reliability they've come to expect.*

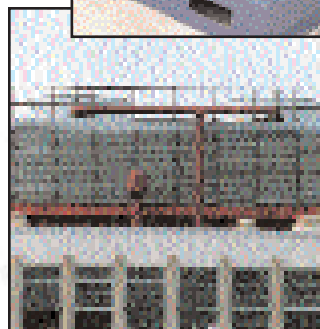
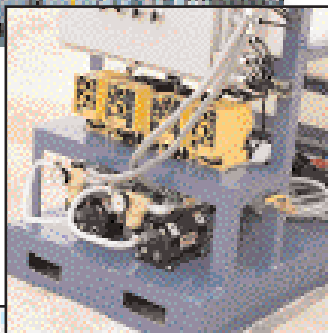
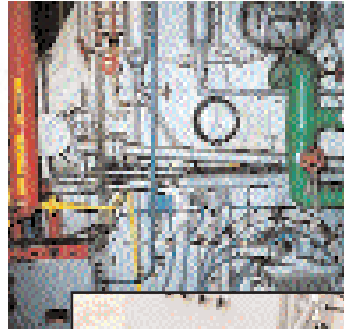

**Waste Water Treatment**

**Cooling Water Treatment**

**Boiler Water Treatment**

**Municipal Water Treatment**

**Fertilizer Injection**

**Laboratory Fluid Metering**

**Fluoridation**

**Paper Chemical Feed**

**Domestic Potable Water**

**Swimming Pool**

## How A Metering Pump Works

LMI's solenoid-driven metering pumps are used for the precise injection of chemicals into a process or system. The mechanically actuated diaphragm design has only one moving part which is permanently lubricated. The simplicity and efficiency of this design results in a pump that consumes very little power, enabling the pump to be totally enclosed in a chemically resistant housing for installation in the harshest environments.

### Durable Stroke Adjustment Mechanism

A rigid stroke bracket and large stroke knob offer precise, repeatable performance and simple adjustment over entire output range.

### NEMA 4X/ IP65 Housings

Totally enclosed, chemically resistant polypropylene housing for the ultimate protection against corrosive environments.

### EPU

LMI's Electromagnetic Power Unit (EPU) is designed for efficiency and consistent performance over a wide operating and temperature range.

### Multi-Function Valves

The industry standard for over 25 years, features Fluorofilm™ diaphragms for long life and ramp style knobs for "hands free" priming with standard 3FV or optional 4FV. The auto prime valve option offers auto degassing for pumping chemicals prone to gassing.

### Fluorofilm™ Liquiframs™

The unique manufacturing process of LMI diaphragms ensures outstanding chemical resistance and flexibility for long life.

### Cartridge Valves

Unique cartridge valves have closely guided balls and triple sequential valve seats for optimum performance over entire pressure range.

### Variety of Liquid Ends

A wide selection of liquid handling assemblies including PVDF, PVC, Acrylic, Polypropylene, 316 SS, and UHMWPE. Configurations for viscous chemicals and slurries provide flexibility in all applications.

### Accurate Speed Control

Provides precise stroke rate and a turndown ratio up to 1000:1 for unmatched versatility.

### Fully Encapsulated Electronics

Completely enclosed electronics provide protection against moisture, corrosive atmospheres and damage from vibration or mechanical shock.

### Pump Status LED

Status LED provides a quick visual indication of pump speed and operation.

### Manual or External Control

Dual-manual control of speed and stroke length or external control by means of a 4-20 mA or pulse input for flow proportional applications and system integration.

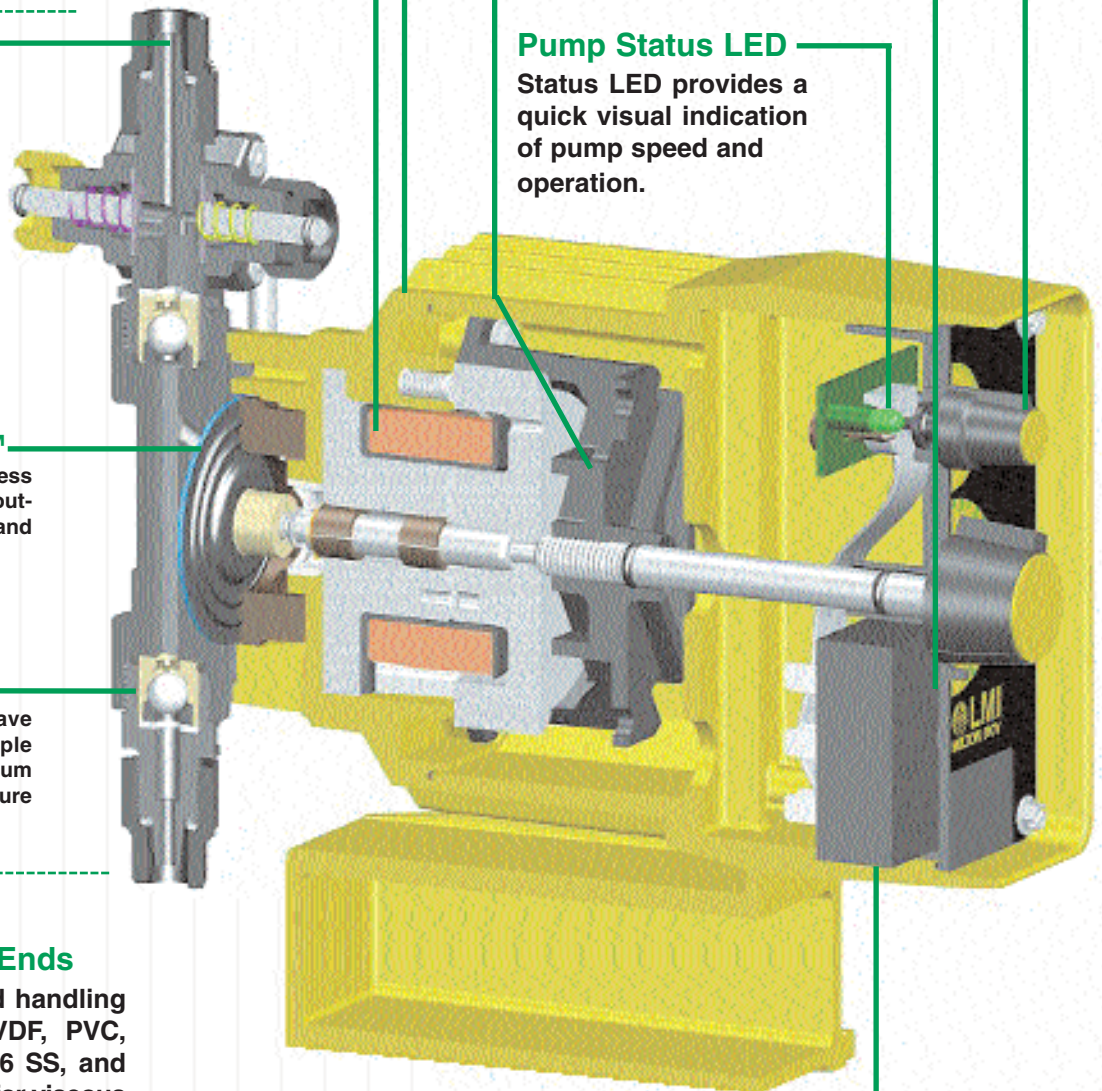

# Electronic Metering Pumps

LMI's family of electronic metering pumps offer:

- Adjustable stroke frequency and the flexibility of up to 1000:1 turndown ratio
- Manually adjustable stroke length provides accurate pump output adjustment
- NEMA 4X / IP65 enclosures for protection against corrosive environments
- Time tested electronics for reliable, repeatable performance
- Totally encapsulated electronics for protection against moisture and corrosive conditions
- Priming valves with Fluorofilm™ diaphragms and ramp style knobs for “hands free” priming

## Series AA



### Key Features / Benefits

- Rigid stroke bracket assembly for highly accurate/consistent dosing performance
- Advanced control options for simplified system integration (pulse multiply/divide, 4-20 mA, remote on/off)
- 5-level power control option to reduce system shock and extend the life of the pump
- External pacing for flow proportional applications

Model	Max Output		Max Pressure	
	GPH	l/h	PSI	Bar
AAX4	0.58	2.2	250	17.3
AAX5	1.0	3.8	110	7.6
AAX6	2.0	7.6	50	3.5
AAX7	0.42	1.6	140	9.7
AAX8	0.75	2.8	80	5.5

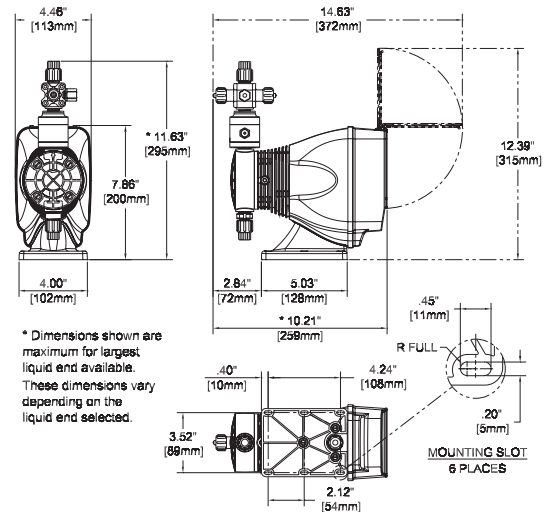

## Series B / Series C



### Series B

Model	Max Output		Max Pressure	
	GPH	l/h	PSI	Bar
BX1	1.6	6.1	150	10.3
BX2	2.5	9.5	100	6.9
BX3	4.5	17.0	50	3.5
BX4	7.0	26.5	30	2.07

### Series C

Model	Max Output		Max Pressure	
	GPH	l/h	PSI	Bar
CX0	1.3	4.9	300	20.7
CX1	2.5	9.5	150	10.3
CX2	4.0	15.1	100	6.9
CX3	8.0	30.3	60	4.1
CX4	20.0	75.7	25	1.7
C76	4.0	15.1	175	12.1
C77	10.0	38.0	80	5.5
C78	25.0	95.0	30	2.07

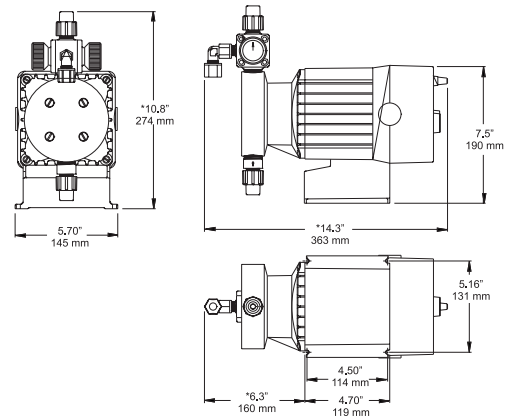

## Series P



### Key Features/Benefits

- High quality construction for durability
- Compact size; ideal for OEM applications
- Fixed speed versions for simple, low cost applications

Model	Max Output		Max Pressure	
	GPH	l/h	PSI	Bar
PX2	0.21	0.79	150	10.3
PX3	0.42	1.6	110	7.6
PX4	0.58	2.2	250	17.3
PX5	1.0	3.8	110	7.6
PX6	2.0	7.6	50	3.5

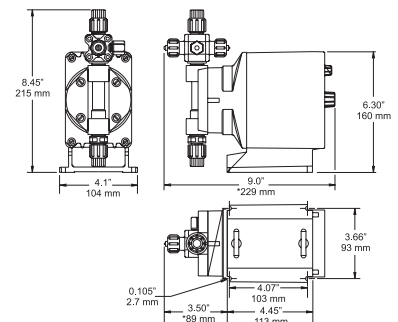

# Specialized Electronic Metering Pumps

## Series E7 Explosion Proof

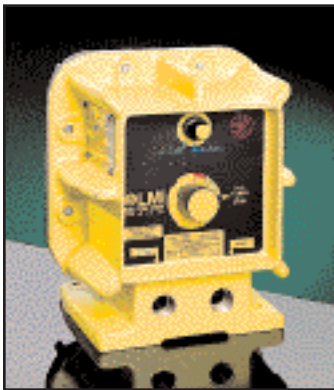

### Key Features/Benefits

- Rugged, urethane coated cast housing for applications in hazardous environments
- Manual control or external control without the need for costly motor and control options
- Designed to meet or exceed all standards for Class I, Division I, Groups C and D; Class II, Division I, Groups E, F, and G

Model	Max Output		Max Pressure	
	GPH	l/h	PSI	Bar
E70	1.3	4.9	300	20.7
E71	2.5	9.5	150	10.3
E72	4.0	15.1	100	6.9
E73	8.0	30.3	60	4.1
E74	20.0	76.0	25	1.7

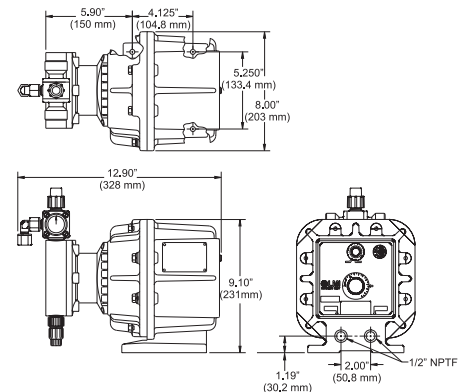

## Series H9 High Pressure



### Key Features/Benefits

- Unique liquid handling assembly for low output injection into high pressure systems
- Advanced control options for system integration (pulse multiply/divide, 4-20 mA, remote on/off)
- 5-level power control option to reduce system shock and extend the life of the pump

Model	Max Output		Max Pressure	
	GPH	l/h	PSI	Bar
H91	0.14	0.50	300	21
H92	0.10	0.38	600	42
H93	0.07	0.25	1000	70

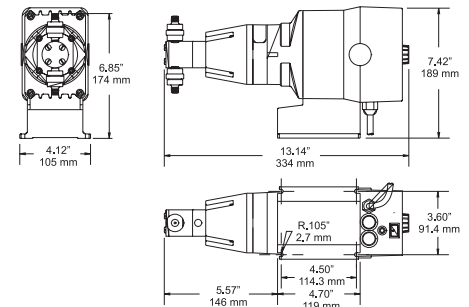

## Series J5 12 VDC



### Key Features/Benefits

- 12VDC power for remote applications where AC electrical power is unavailable
- Low power consumption (1.6 amp average current draw or 19 watts at maximum speed)
- Manual or external control for flow proportional applications

Model	Max Output		Max Pressure	
	GPH	l/h	PSI	Bar
J54D	0.42	1.6	140	9.7
J55D	1.0	3.8	60	4.1
J56D	2.0	7.6	20	1.4

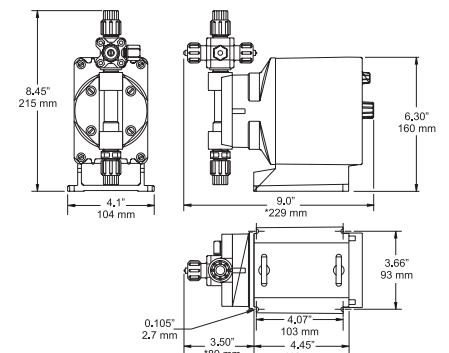

# Motor Driven Metering Pumps

## Series G

### Model SD & Model SG



#### Features / Benefits:

- Mechanically actuated diaphragm (MAD)
- Variable eccentric design delivers smooth output
- Variable speed drives for external control (4-20mA)
- Durable metallic housing designed to withstand tough environments
- Liquid end materials: PVC, Polypropylene, PVDF and 316 S.S.

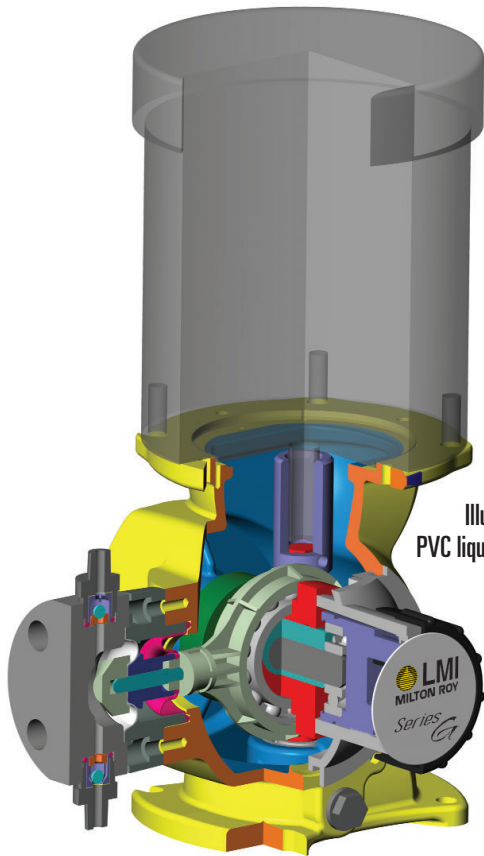

Illustrated to the left is a SD4 with a PVC liquid end, featuring NPT connections.

Model SD				
	Max Output Range		Max Pressure	
	GPH	l/h	PSI	Bar
SD2	0.18 - 0.7	0.7-2.6	175	12
SD4	3 - 12	11.4 - 45	150	10
SD7	12.5 - 50	47-189	100	7
SD8	28 - 115	106 - 435	75	5
Model SG				
SG5	26 - 106	98 - 400	150	10
SG6	36 - 147	136 - 556	100	7
SG7	75 - 300	284 - 1136	50	3.5

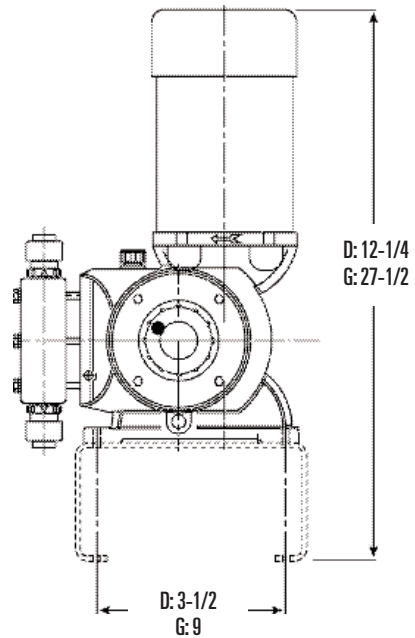
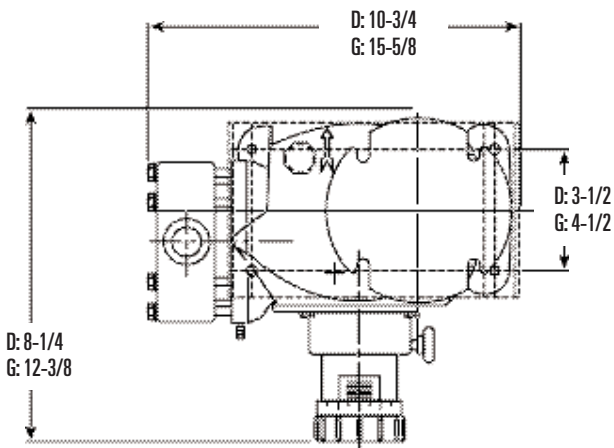

## Liquid Handling Assemblies



LMI offers a wide selection of liquid handling assemblies with flexible tubing and pipe thread connections. Configurations for viscous chemicals and slurries provide total flexibility in all applications

- PVC
- Acrylic
- Polypropylene
- PVDF
- UHMWPE
- 316 SS

## Repair & Preventative Maintenance Kits



RPM Pro Pac™ kits include the recommended replacement parts for the LiquiPro™ Series Metering Pumps. These kits provide an easy, economical solution to annual pump maintenance.

## Accessories



LMI offers a complete line of accessories to customize and complete your installation.

- Auto prime valve  
4FV/3FV/Bleed 4FV
- Agitators
- Back Pressure Valves
- Calibration Cylinders
- Conduit Connection Kit
- Corp Stop &  
Nozzle Assemblies
- Digi-Pulse™ Flow Monitors
- Extension Cable Assemblies
- Flow Indicator
- Fluoride Saturator
- Flowmeter
- Remote Programmable  
Flowmeter
- Liquid & Low Level Switches
- Micropace™ Control Modules
- Pressure Relief Valves
- Primer Flush Kit
- Pulse Transmitter
- Pump Mounting Accessories
- Remote Auto Flush Controllers
- Seal Ring Kit
- Splash Guard
- Suction Tubing Accessories
- Syphon Breaker
- Tanks
- Tubing Connector Assemblies





**Liquid Metronics Incorporated**  
**201 Ivyland Road**  
**Ivyland, PA 18974 USA**  
**Tel: (215) 293-0401**  
**Fax: (800) 327-7563**  
**[www.lmipumps.com](http://www.lmipumps.com)**

*Digi-Pulse, Micropace, Liquifram, Fluorofilm, LiquiPro, Liquitron, RPM ProPac and PGC are trademarks of Liquid Metronics Incorporated.*

© 2003 LMI Milton Roy - All Rights Reserved  
Printed in USA  
Specifications subject to change without notice.

Replaces same of Rev. C 12/99  
1883. D 08/03