

WB-448  
WHEEL BALANCER  
OPERATION MANUAL

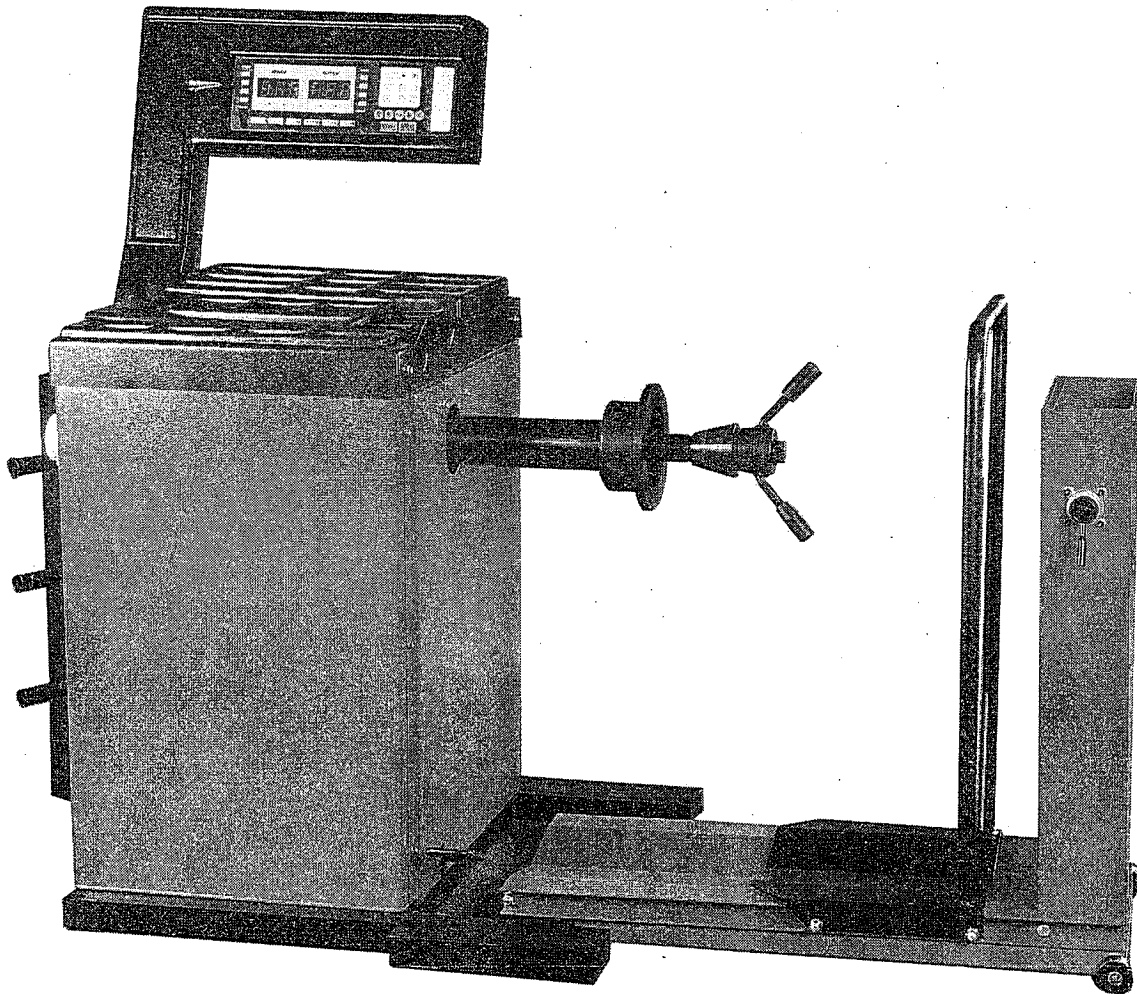

## CONTENT

WARNING-----	1
INTRODUCTION-----	1
INSTALLATION-----	2
ELECTRICATION CONNECTION-----	2
SAFETY REGULATION-----	3
BRIEF INTRODUCTION ON THE WHEEL BALANCER-----	4
MEANING OF THE LABEL-----	4
APPEARANCE OF THE MACHINE-----	4
CHARACTERISTIC AND FUNCTION-----	4
OPERATION NOTE-----	6
GENERAL OPERATION-----	6
TRANSPORT-----	7
DETACHING THE PACKAGE-----	7
OPERATION OF THE MACHINE -----	7
TRANSPORTATION AND INSTALLATION -----	7
HANDOVER NOTE-----	8
CABLE OF THE MACHINE -----	8
PNEUMATIC CIRCUIT-----	8
INSTALLATION SITE-----	9
MOUNTING THREAD SHAFT-----	9
DISPLAY CONSOLE -----	11
SETUP OPERATION-----	12
MOUNTING TIRE-----	13
INPUTING TIRE PARAMETER-----	14
RESIDUAL UNBALANCE DISPLAY-----	15
BALANCE MODE INTRODUCTION-----	15
ERROR HINT-----	16
STANDARD DYNAMIC BALANCE-----	17
STATIC BALANCE-----	18
WEIGHT CALIBRATION PROGRAM-----	19
PIEZOELECTRICITY SENSOR INSTALLATION AND CABLE-----	20
TROUBLESHOOTING AND ITS SOLUTION-----	21
WHEEL BALANCER ACCESSORY-----	22
MAINTENANCE-----	22
LUBRICATION-----	22
ATTACHMENT I -----	25
ATTACHMENT II -----	26
ATTACHMENT III -----	27

## WARNING

On the condition that confirm the operation of the machine including the operation system, tools and accessories operated properly and/or without being damaged, you can have some period limit of the guarantee during which the manufacturer will repair and change the fault parts of the machine or the machine itself free of charge. But to the faults of wear or damage caused by the improper use or transportation or the maintenance undone, the producer will not bear any responsibility. The manufacturer will not notify the customer if she has made the modification on the products of improvement on the production line.

## INTRODUCTION

The aim of this manual is to provide the owner of the machine and the operator with a series of instruction on the safety and practice for operating and maintaining the wheel balancer.

If you carefully comply with this instruction manual, the machine will give you the service of high efficiency and endurance.

The following paragraphs will supply you with the danger level related to the machine.

## DANGER



Can cause the direct dangerous of severe injuries or

death



## WARNING

Can cause the dangerous of severe injuries or death or operation unsafe.



## NOTE

Can cause the dangerous of slight injuries or damage to the subject and operation unsafe.

Carefully read the instruction before use the machine. Keep the instruction manual in the folder need the operation area for the operator to check at any time.

Technical document is the component of the machine and has been placed together with the machine when it is sold to the new owner.

It is considered to be effective when the series number and the model in the manual are same to the ones on the nameplate.



## WARNING

You must keep the instruction and information in this manual in mind and comply with them. The operator will be responsible for the operation unmentioned in the manual.

## Note

Some instructions are taken out from the pictures and original figures, therefore, they will be somewhat

different from the standard machines.

These instructions are applied to call for the notice of the personnel with some basic mechanical skills. So we concentrate these instructions by omit the detailed descriptions such as how to loose of tight the fix device. Do not try the other operation besides under the guide of the experienced person. If necessary, please contact the authorized service center for help.

#### INSTALLATION



Detach the package, lift and install the machine in accordance with the following instruction.

It will damage the machine or endanger the safety of the operator.

Detach the original package of the machine according to the package position pointed.



The choice of the installation site of the machine must comply with the current safety regulation.

Especially, the installation and operation of the machine must have the protective to moisture-resistance.

**IMPORTANT:** Correct and safe use of the machine, the min. luminosity of the machine must be at least 300lux

The use condition requirement:

- RH: 30% —80% (without co0ndensation);
- Temperature range:0°—+55°C.



The floor to fix the machine if solid enough to support the max. load of the machine.



The machine cannot be used in the exploded environment.

The package of the machine is separate package and the assembly will be in accordance to the following methods described.

#### ELECTRICAL CONNECTION



Any electrical connect to the machine will be only executes by the qualified personnel and should be in accordance with the current regulation.

Any electrical connect should be in accordance with :

- power on the nameplate of the machine;
- Voltage drop will not exceed 4% of the rated voltage specified on the nameplate when full load. It is 10% when start up.

-User must:

- Install the plug : Connect the plug with the

corresponding specification according to the voltage label and ensure the power source parameter is the same.

- Electrical connect to the machine: Install the suitable electrical current circuit breaker.
- Install power cable fuse.
- Provide the effective workshop electrical installation.
- Avoid the prohibited machine operation. Pull out the power plug to extend the life of the machine when the machine is not in use or it is in the state of switch off.
- If the machine directly connected with the power source through the power board. It should be operated by the qualified person if without using the plug.



Perfect earth is necessary for the correct operation of the machine. Do not connect the earth with the pipe line, water pipe, telephone cable and the other improper objects.

#### Safety regulation



It will cause the serious injuries to the operators and the other persons if not in accordance to the regulation.

You can only operate the machine when completely read and understand the entire danger/warning hints.

The correct use of the machine need the professional authorized operator who must has got the appropriate

training and can understand the instruction manual of the factory, familiar to the safety regulation and cannot drink and smoke to avoid the influence on the physiological and mental.

The following conditions are necessary:

- Read and understand the info and instruction in the manual;
- completely know the characteristic and feature of the machine;
- Keep the unauthorized person far from the operation area;
- Secure the installation of the machine in accordance with the relative standard and regulation;
- Secure all the machine operators have been trained and can correctly and safety use the machine and under the enough monitoring in the process of operation.;
- Before confirm the power off, do not touch the cable or motor or any part in the electrical equipment;
- Carefully read the manual and know how to correctly and safely use the machine;
- Always refer to the manual.



-Do not remove or abrade any label of the warning and instruction on the danger or replace the label missing or fuzzy. You must get the label from your nearest dealer if any label is missing or damaged.

-Check the use and the relative accident defensive regulation of the standard and the high-voltage and

rotation parts.

The manufacturer will not be responsible for the damage and accident from the unauthorized changes or modification.



In the work and maintenance, you should always tie up the hair and do not wear the loosen clothing, necktie and watch or the others can be gripped into the movable parts.

#### BRIEF INTRODUCTION ON THE WHEEL BALANCER

##### Purpose of the design

This model of wheel balancer with the functions of CPU, digital display and high performance is designed to balance the car or van tire of 65kg. ALU mode make us balance the various appearances of the aluminum alloy tire.

##### Meaning of the label

(including the indicated instruction)



This label is at the rear of the machine to indicate that there is the plug of the power cable and the operator should care about the personal safety.



rotation

part

This label is near the balance shaft and hint the operator that this is a rotation part which is dangerous and should not use your hand to touch it. The indication of the arrow is the direction of the rotation.



grounding

This symbol is located on the left rear to indicate where to connect the earth wire.

#### APPEARANCE OF THE MACHINE

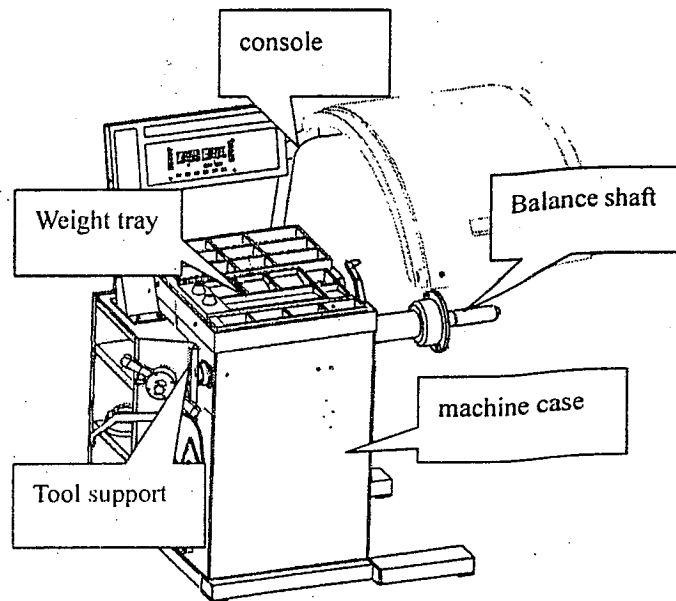

#### CHARACTERISTIC AND FUNCTION

- Apply the central synthesis signal manage system with the characteristic of high intelligent and long life.
- Main shaft adopts the high quality bearing with the characteristic of low noise and high precision.
- Advanced computer instructive system
- Automatic brake

- Sop button used to immediately stop the spin of the tire
- Side bracket
- Weight tray
- The use of the balance mode
- Standard- Dynamic (two sides of the tire)
- ALU - to balance the alloy rim;
- Static- one side
- General application
- Self-calibration
- Service
- Diagnose

No.	Item	Technical data	Remark
1	Type of the rim	aluminum/steel/siloy	
2	Type of the tire	Car, van and truck	
3	Mode	Dynamic, Static and 5 ALU modes	
4	Driven	electrical	
5	Power source	According to the requirement of the customer	
6	Weight type	standard	Adapt different rim
7	Inside/outside measure	standard	Adapt different model
8	Machine start when hood lower down	optional	Adapt different model
9	Quick nut with	standard	Adapt different model

	handle		
10	Caliper/weight/handle	standard	Adapt different rim
11	mm/inch conversion	standard	Adapt different model
12	g/ounce conversion	standard	Adapt different model
13	Calibration	standard	Adapt different model
14	Self-diagnose/error	standard	Adapt different model
15	Brake	Automatic	
16	Manual brake	no	CPU display
17	Display protection	separate package	
18	Display panel	LCD	
19	Distance setup	manual	
20	Cone	standard	customer specify
21	Balance cycle	7s (16" standard rim)	up to the weight of the wheel
22	Max. speed	200 rpm (car), 100 rpm (truck)	up to the weight of the wheel
23	Accuracy	± 1g	
24	Max. wheel breadth	20"	
25	Max wheel diameter	40"	
26	Max rim	10"~24"	

	diameter		
27	Wheel breadth	1.5"~20"	
28	Max. wheel weight	130kg	
29	Package size	1300mmX1000mmX1150mm	Outer package
30	Weight of the machine	220KG	net weight
31	Temperature	0°~40°	
32	Humidity	< 75% (without condensation)	
33	Noise	< 70 dB	
34	Resistance	> 20 MΩ	
35	Power	Approx. 300W	
36	Weight of the electrical / electronic element	10kg	

#### OPERATION NOTE

Note for the transportation of the machine

- A. Note : Avoid the damage in the process of transportation and de-package
- B. Check if there is damage in the transportation. If there is damage, tell the carrier and form the appropriate document.
- C. Check the structure to secure the required data of the machine is corresponding to the ones on the motor identified plate. Please contact with the dealers as soon as possible to solve the problem as soon as possible.

D. Do not ask the unauthorized person to adjust and operate the electrical system.

#### General operation

The wheel balancer in this manual is specially used to measure the unbalance value and unbalance position. The range of the measurement see the part of the technical data.



Any instruction not specified in the manual is considered to be inappropriate and unreasonable operation.



Do not start the machine without the tire lock facility.



Do not use the machine and touch the safety device without the hood.



Do not use the compressed air and the water spray pipe to clean the tire mounted on the machine.



During work, we suggest you had better not use the original parts and equipments



The best solutions to understand your machine to secure your machine to have the top performance and avoid the occurrence of the accident:  
Secure the operator understand the machine and know the performance and the position of the entire control



devices.

Carefully check if the entire control devices of the machine is normal or not.

The installation of the machine must be appropriate and the operation is correct and periodically maintenance to avoid the damage and accident.

#### Note the following issues

- Do not detach the wheel balancer by yourselves.
- Do not collide the rotation part of the shaft



- You should wait for 5 seconds to restart after power off.
- Do not place too many heavy objects on the wheel balancers.
- If you hear the strange voice and see the smoke or any other problems, power off and pull out the plug and notify the technicians assist.
- The wheel balancer cannot be used for the other purposes not specified in the manual.

#### Transport

Wheel balancer must be transported by the original package and place according to the position indicated on the package box and carried by the forklift with the corresponding lift capacity. The insert direction of the forklift must be in accordance to the direction in the picture.

#### DETACHING THE PACKAGE

- Open the protective cartoon or wood cartoon or the plastic bag and check the machine is complete or not and if the spare parts is missing or not.
- Remove the anchor bolt and detach the wheel balancer but we cannot carry the mail shaft of the wheel balancer.
- If you have any question, do not use the machine and contact with the supplier at once.

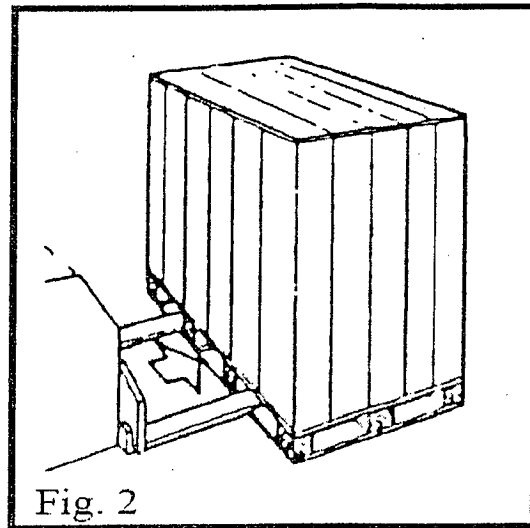

Fig. 2

#### OPERATION OF THE MACHINE

#### TRANSPORTATION AND INSTALLATION

- Transport and move the machine in the direction of the figure.

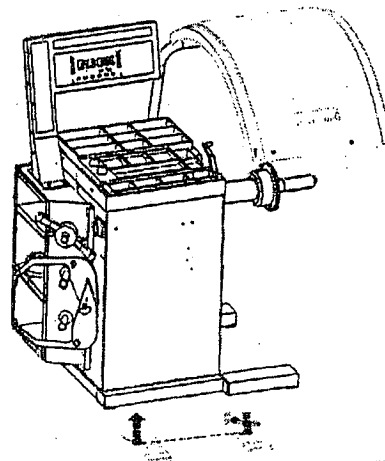
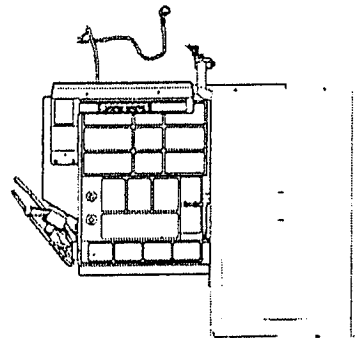

FIG 3



## HANDOVER NOTE

- A. When transport the machine, be careful to avoid the scratch and collide of the machine.
- B. Carefully check if there are any damage or fault in the process of transportation. Make the problems be the report which will be sent to the carrier and make mark and explanation on the goods handover documents.
- C. Check the construction of the machine and the data on the nameplate of the product and the motor is corresponding to the order. Timely feedback if you have any question to adopt the remedy ASAP.
- D. Wiring and commission of the machine must be done by the qualified person.

## CABLE OF THE MACHINE

A. Requirement of the circuit: Before wiring, you must confirm the electrical parameters. The power parameter from the user must comply with the electrical parameter of the machine. When use the machine, the user cannot directly connect the power cable with the circuit and they should specially equip a circuit breaker to avoid the damage to the machine for the abnormal in the circuit. Normally, we can choose the 15A dual pole or tri-pole circuit breaker with the overload protection and come off for the under-voltage. If you want to use the large circuit breaker, you should equip the additional fuses in the circuit. The metal cross section of the lead should be not less than 1.5mm and you can select 1.0mm<sup>2</sup> for the ground. If the environment is bad or frequent access and exit of the equipments and persons, the power cable should be buried underground or in the air.

B. Requirement of the power source: Voltage of the power source should be stable and the circuit should have some overload capacity. The voltage fluctuate should not exceed 10% of the rated voltage and the frequency fluctuate will not exceed 1Hz. Or you should add the voltage and frequency stabilizer to keep the stable of the voltage and frequency.

C. Requirement to the socket: Small size wheel

balancer should be equipped with the power cord and the plug before out of the factory. The customer should directly equip the socket adapted to plug. But the use of the socket must meet the following requirements:

I rated capacity exceeds 500VA and the rated current exceeds 15A;

II Socket must have the reliable earth wire and you cannot use the two pole socket without the earth wire for the missing of the earth wire will influence the accuracy and interference-resistance of the wheel balancer. III The best socket is one with the switch. The circuit can break the circuit and cut off the power to avoid the damage to the machine. 线路

V The best way is to have a special socket to power the machine and not connect several electrical device on one socket.

## PNEUMATIC CIRCUIT

A. Technical parameter of the lift:

Work capacity: 0.1~0.8MPa (0.5~0.8MPa for normal operation )

Accuracy: 0.01MPa

Air source: This machine is not equipped with the air supply which will be supplied by the customer. The air pressure of the air source should be controlled in the range of 0.6~0.9MPa. Then use the pressure reduction valve on the lift to below 0.8MPa. The air supply must be equipped with the filtration device and the accuracy of the filtration should be 5 $\mu$ m. The medium flow >0.15m<sup>3</sup>/min and the temperature should be 5~60 $^{\circ}$ C. The lift is equipped with the quick connect and the customer can insert the rubber hose of  $\Phi$ 8 into the air source connect of the lift and use the fastener to tight it. It is OK.

Environment: In accordance with the requirement of the wheel balancer

NT: 50Kg

size: 1129 $\times$ 1190 $\times$ 728mm (L\*W\*H)

B. Air pressure conversion

1Mpa=10Bar  
 1Bar=14.5Psi  
 1Bar≈1Kg/cm<sup>2</sup>

Environment: In accordance with the requirement of the wheel balancer

NT: 50Kg

Size: 1129×1190×728mm (L\*W\*H)

B、Normal conversion of the air pressure

1Mpa=10Bar  
 1Bar=14.5Psi  
 1Bar≈1Kg/cm<sup>2</sup>

Pneumatic theory diagram

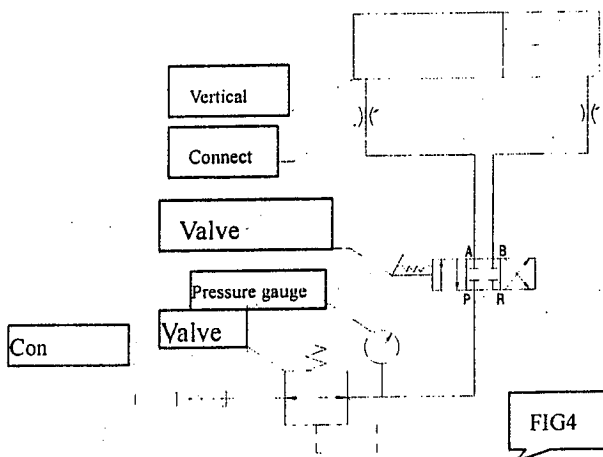

Operation and operation caution:

\*Do not install the machine in the area too hot or too cold and avoid placing the machine near the heater, cock, air humidity device or the oven.

\*Do not place the machine close to the window to avoid the direct sunlight. If installed by the window, you should equip the shield to cover the machine such as curtain.

\*Keep the machine from the chemicals such as dust, ammonia, alcohol, thinner, power and adhesive etc.

\*Do not install the machine near the equipments can

produce the vibration and the air compressor.

\*In the process of operation, except the operator, any other person can not close the machine in using.

\*Dynamic wheel balancer must use the separate rated power source and connect with any other electrical equipment to the socket. If without the reliable earth power source, you must provide the reliable power source.

\* The input power cable must be firmly fixed.

\* If you have to move the wheel balancer, you must equip the protective device to avoid the damage to the machine.

### INSTALLATION SITE

\*The distance between the rear of the wheel balancer and the wall is more than 80cm and the distance between the left panel and the wall should be more than 50cm to secure the perfect ventilation and the limit of space to the operation and the distance between the right panel of the case and the wall should be more than 200cm to make it convenient to mount and demount the tire and mount the lift device for the tire.

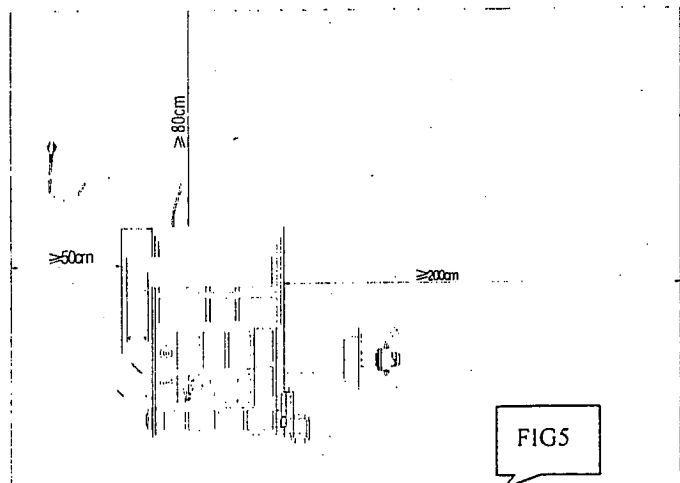

### MOUNTING THREAD SHAFT

Before using the machine, you should mount the thread shaft on the main shaft of the machine. Before install

the thread shaft, use the cotton yarn to clean up the link between the main shaft and thread shaft and then use spanner to firmly mount the thread shaft on the main shaft by following the figure.

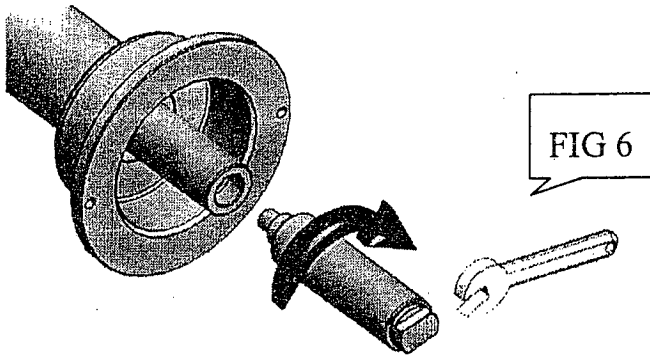

FIG 6

\*When the weight of the tire exceeds 15kg, you should use the lift to carry the tire and not by hand to avoid the injury to the person.

\*Before operating the wheel balancer, you must use the anchor bolt to fix at 3 points, or it will produce the vibration to cause the inaccuracy of the test result, especially the weight of the tire exceed 35kg.

\*The machine is equipped with protective hood and the interlock switch. When the hood lower the motor will automatically start up and the motor will stop when raise the hood. Please do not remove the hood for your safety.

\*The operator should wear the close-fitting work suit, it is necessary to line up a good clothing button or pull pouch hung from belt. The gloves should be the thin gloves. When operation, cannot wear the sandals and it is best to wear the insulation shoe.

\*When the machine in operation, there should not be the other electronic equipments of the high-power equipments to avoid the electromagnetic interference to the machine-generated, affecting the accuracy of the test machine.

If the light of the workplace is bad, lighting equipment shall be ready by you. The ordinary fluorescent or incandescent lighting is better, it is no need too bright, the brightness not affecting any operation is appropriate

2.5)

Please pay attention to the following

Do not refit the wheel balancer by yourself.

The rotating main shaft must have the protection to the bump.

After the dynamic wheel balancer is switched off, it must be restart after 5seconds.

Do not place too many heavy objects on the wheel balancer.

If there is any abnormal situations such the sudden noise, smoke of any other special situation, you must pull out the power source plug immediately and notify the service person.

There should be the enough space at the area of the plug of the wheel balancer to pull out the plug very easily.

The wheel balancer cannot be used for the operation not specified in the manual and cannot used to execute the functions not belonging to the functions of the wheel balancer.

The note to the wiring of the power cable

If the machine adopts the power source, 3ph 380V/220V/etc, the machine will not equip the plug before out of the factory and it need the customers to connect the power cable. It needs to test after the complete of the power cable. If the motor rotates reversely, the machine will remind the error of reverse. At this moment, you should power off and change the positions of any two live wires to change the rotation direction. In the future operation, you can use normally.

# DISPLAY CONSOLE

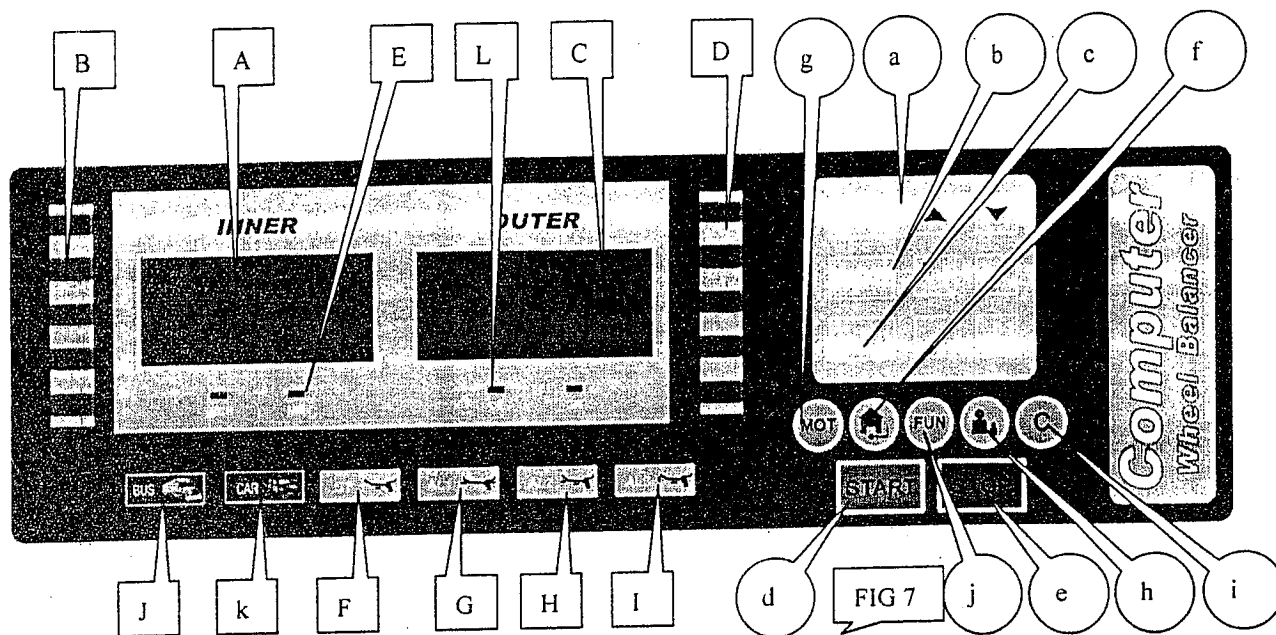

A	Parameter display/ inside unbalance value display	G	ALU1 aluminum mode 1 lamp
B	Inside unbalance position lamp	H	ALU2 aluminum mode 2 lamp
C	Outside unbalance position lamp	I	ALU3 aluminum mode 3 lamp
D	Parameter display/ outside unbalance value display	J	Truck tire balance mode lamp
	Br, Dia unit (mm/inch) conversion lamp	K	Car tire balance mode lamp
F	STA static mode lamp	L	Unbalance value (Gr/Oz) lamp

a	Dis input key	f	Program setup key
b	Br input key	g	truck/car mode conversion key
c	Dia input key	h	Unbalance display key
d	Start press key	i	Gr-Oz mm-inch unit conversion key
e	Stop/exit key	j	Balance mode conversion key



## MOUNTING TIRE

Select the cone adapting to the center hole of the tire and mount on the wheel balancer following the indication of the figure.

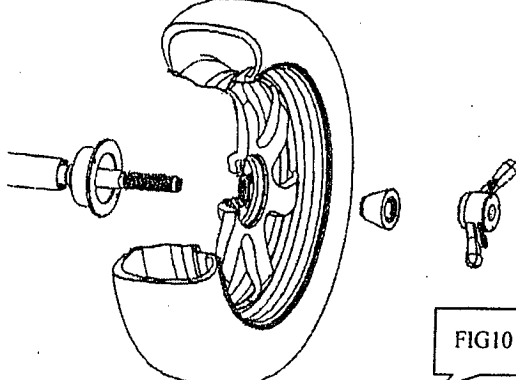
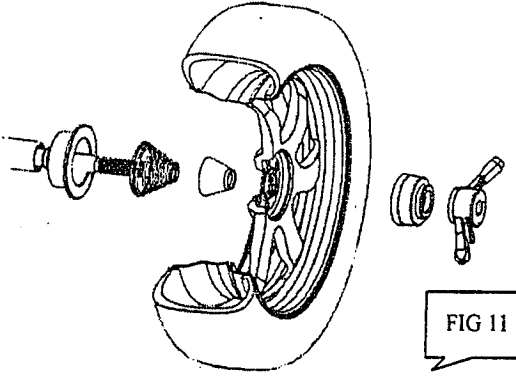
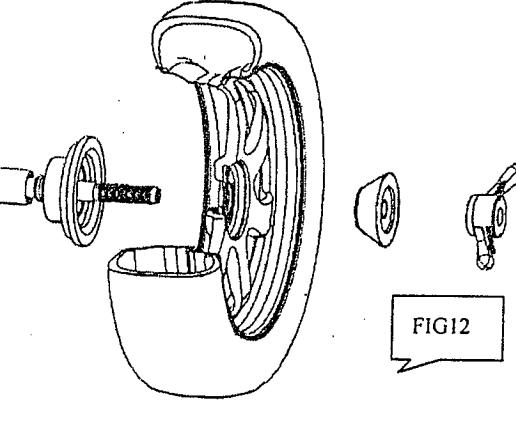
 <p style="text-align: center;">FIG10</p>	<p>Positive positioning is the normal method. It is featured with simple and quick operation. It is mainly suitable to the common steel rim and aluminum alloy rim with small deformation.</p> <p>Main shaft → Wheel (direction of the rim installation surface is inside) → cone → quick nut</p>
 <p style="text-align: center;">FIG11</p>	<p>When the deformation of the outside of the wheel, adopt this method to positioning to guarantee the accurate positioning of the steel rim inner hole and main shaft. It is suitable to the steel rim, especially the thick ALU rim.</p> <p>Main shaft → tower spring → suitable cone → wheel → bowl → quick nut</p>
 <p style="text-align: center;">FIG12</p>	<p>Suitable to the big tire assemble</p> <p>Main shaft → flange disk (fixed on the main shaft) → wheel → cone → quick nut</p>

## INPUTING TIRE PARAMETER

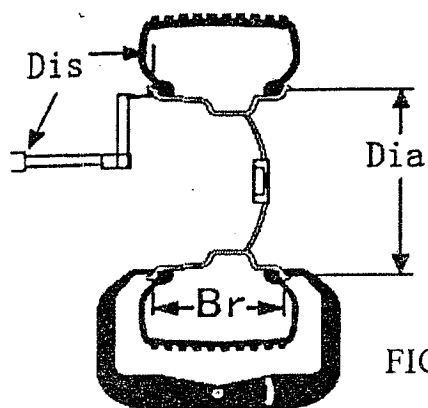

FIG 13

### Input Dis (Distance) Value

Pull the scale to measure the distance from the machine to the rim to the position the weight will be added onto the rim and press the key



to input the value of the scale into the display. At this moment, the display will display "Br": "XXX" and the default unit is inch.

### Input Br(Breadth) Value

Use the Br measurement caliper to measure the Br of

the rim, press the key  to input the

Br value into the display. At this moment, the display will display "Br": "XXX" and the default unit is inch.

### Input the Tire Diameter Value ( Dia )

After confirming the rim diameter, press the key to input the rim diameter into the display. At this moment, the display will display [Dia]—[XXX]" and the default unit is inch.

### UNIT CONVERSION:



①The unit conversion of the Br of the rim from inch to mm:

Normally, the display of Br should be in inch. When you need the unit of the display to be mm, you can use the

key to realize the unit conversion from inch to mm.



②The unit conversion of the Dia of the rim from inch to mm:

Normally, the display of D should be in inch. When you need the unit of the display to be mm, you can use the key to realize the unit conversion from inch to mm.

After unit conversion, the unit of the display values of rim Br and D are mm, but when you switch off and then on the wheel balancer, the unit will be still inch.

③The unit conversion from gram to ounce:



Normally, the unit of the unbalance value is gram (g). If you want to make the ounce(Oz) to be the unit, you can execute the g/Oz conversion.

The unit of the displayed unbalance value is gram (g). The way to realize the unit conversion from gram to

ounce is to press the key .

Press the start key , the wheel

balancer starts to run. A few seconds later, the machine automatically stops. The machine can also start by lowering down the protective cover which can be set by the program. And the machine can also automatically start by the program setup.

### DISPLAY UNBALANCE VALUE

When the spin ends, the display will display the inner

 and outer  unbalance

value of the rim. Use your hand to pull the wheel. When all the positioning lamps light inside and outside light, the weight adding position will be indicated.



Rotate the wheel, when the left side positioning lamp all light, at this moment, the highest position is the inner unbalance position and when the right side positioning lamp all light, at this moment, the highest position is the outer unbalance position.

Add the corresponding weight at the unbalance point and start test again until the balance of the tire.

## CAUTION

1. When start the machine, use hand to pull the wheel to help it start rotation, especially to the relative bigger tire, to prolong the working life of the motor.
2. Check if there are any mistakes on the dimension.
3. Check if the balance methods meet the configuration of the rim and select the balancer most easily to balance.
4. Check if the contract nut tight or not.
5. When the balance ends, remove the tire. Pay attention to handle it with gentle and avoid knocking the main shaft. When clipping the weight. Use the hammer to clip the weight on the rim without too much force. Do not knock the main shaft hardly to avoid damaging the sensor. The position to add the weight should be free from the grease and should be dry.

### RESIDUAL UNBALANCE DISPLAY

The minimum value of the standard weight is 5g so if the weight you use is less than 5 g, the wheel balancer will not display the value and only displays the state of "00". When you need to display the residual unbalance

value, you should press  and the display will immediately display the inside or outside unbalance value of less than 5g. The maximum residual unbalance value is 4 g.

### BALANCE MODE SELECT

Select the balance mode according to the weight adding position and the balance mode. Press the mode



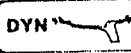
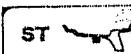
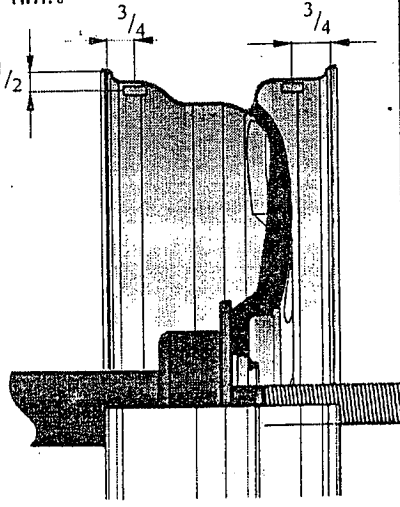

switching key  to select the balance mode.

When you switch on the machine the machine will automatic enter into the dynamic balance mode and no need to select.

## BALANCE MODE INTRODUCTION

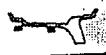
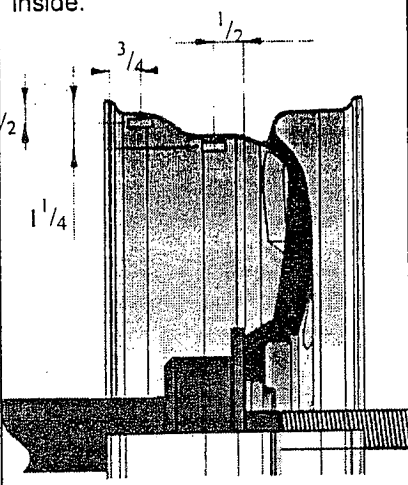
	<p>Dynamic—clip the weights on both sides of the Rim. It is Dynamic balance test after the boost of the wheel balancer. The default mode is the dynamic balance. That means it is the common dynamic balance mode when all the function indication lamp not light.</p>
	<p>Static—static amend the rim without adding the weights on both sides..</p>
<p>ALU1</p> <p>Dis1=Dis+3/4"</p> <p>Dis2=Dis+Br - 3/4"</p> <p>D1=D-1"</p> <p>D2=D-1"</p>	<p>ALU1—to balance the aluminum alloy rim by applying the weight on the 2 shoulders of the rim..</p> 

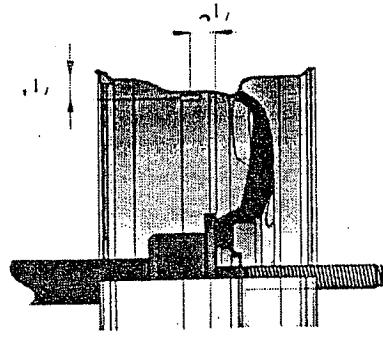
vill  
no

<p><b>ALU2</b> </p> <p>ALU2</p> <p>Dis1=Dis+ 3/4" Dis2=distance from 0 point to the outside of the flange disk - 1/2" Dia1=Dia-1" Dia2=Dia - 2 1/2"</p>	<p>ALU2—to balance the aluminum alloy rim by hiding the weight inside.</p> 
<p><b>ALU3</b> </p> <p>ALU3</p> <p>Dis=Dis Dis =distance from 0 point to the outside of the flange disk - 1/2" Dia=Dia DIA2=Dia - 2 1/2"</p>	<p>ALU3—clip the weight inside and stick the weight outside (outside position as ALU2)</p> 
<p>When balance heavy-duty vehicles such as truck, please</p> <p></p> <p>press and the truck balance mode light</p>	

When balance the car, please



press and the car balance mode light.



FIG 14

**SUPPLEMENTARY EXPLANATION:**

Once switching on, you will see standard dynamic balance mode setup by the computer. When selecting ALU mode and the configuration of the aluminum alloy rim is similar to the above standard ALU1\ALU2\ALU3, you can get relative accurate balance effect. If the section of the tire similar to the one given be the program, you need do some adjustment on the position and weight of the weight. General speaking, 1~2 times of adjustment can reach relative satisfactory balance effect.

**ERROR HINT**

DISPLAY	REASON	SOLUTION
ERR OPN	protective hood not lower	Lower down protective hood.
ERR SP	rotation speed not enough	Check belt and motor.
ERR OFF	stop error	Press the start key or raise the protective hood.
ERR FAC	factory setup error	Correctly execute the factory setup.
ERR USR	customer setup error	Execute the customer setup.

# STANDARD DYNAMIC BALANCE

It is used to test the unbalance value inside/outside when the wheel spin. Add the weight according to the balance point outside/inside tested and remove the unbalance when the wheel spin.

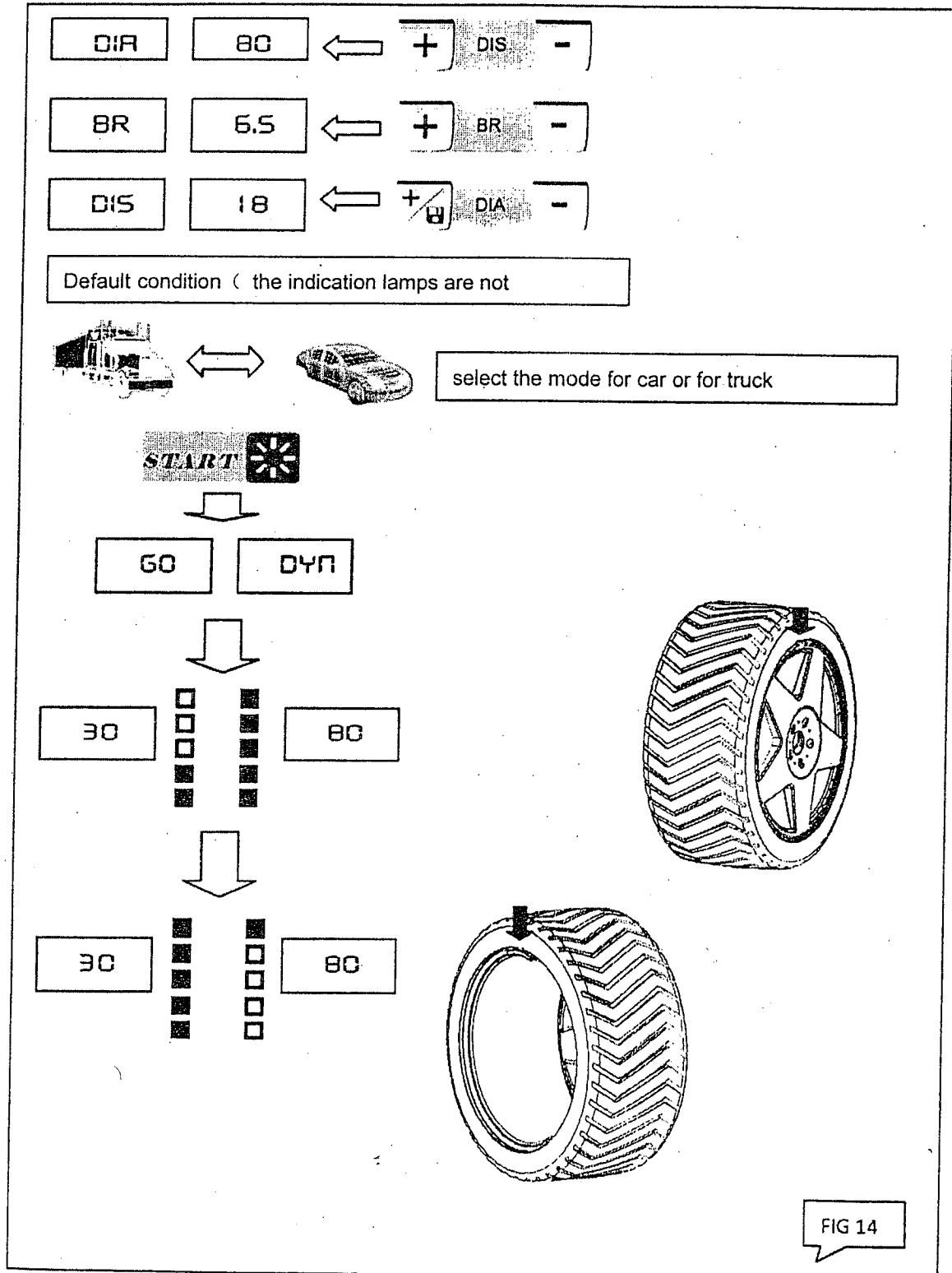

# STATIC BALANCE

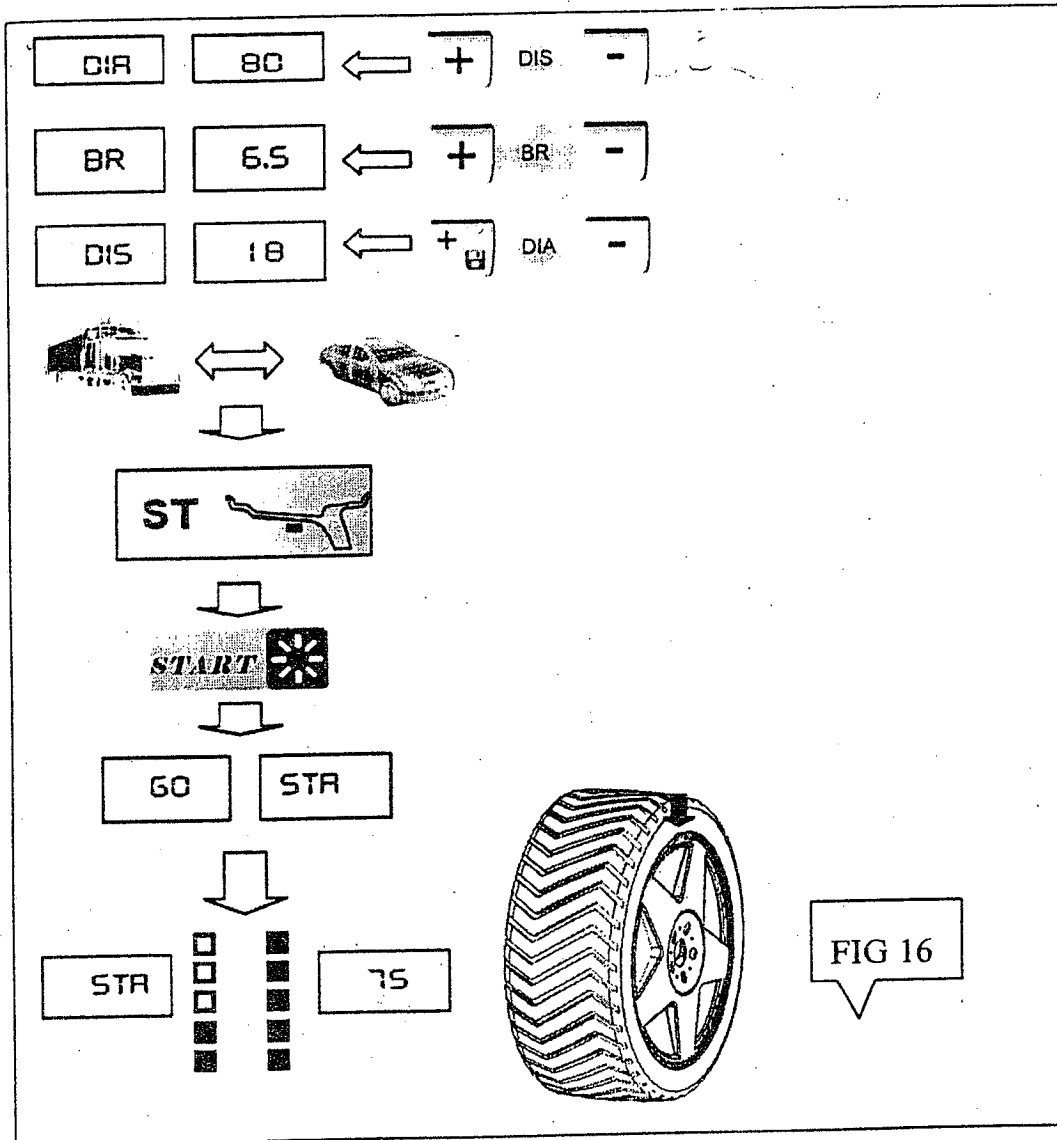

FIG 16

ALU Aluminum alloy rim balance mode

ALU is the approximate weight summarized from the different sizes of the rim.

See the introduction of the balance modes.(FIG 15).

Press **FUN** to enter in cycle **ST** → **ALU1** → **ALU2** → **ALU3**

and the static mode. ALU mode applies the clip of the weight according to the weight clip position in FIG15.You can also select the weight special scale to assist the completion of the weight clip.

# Weight calibration program

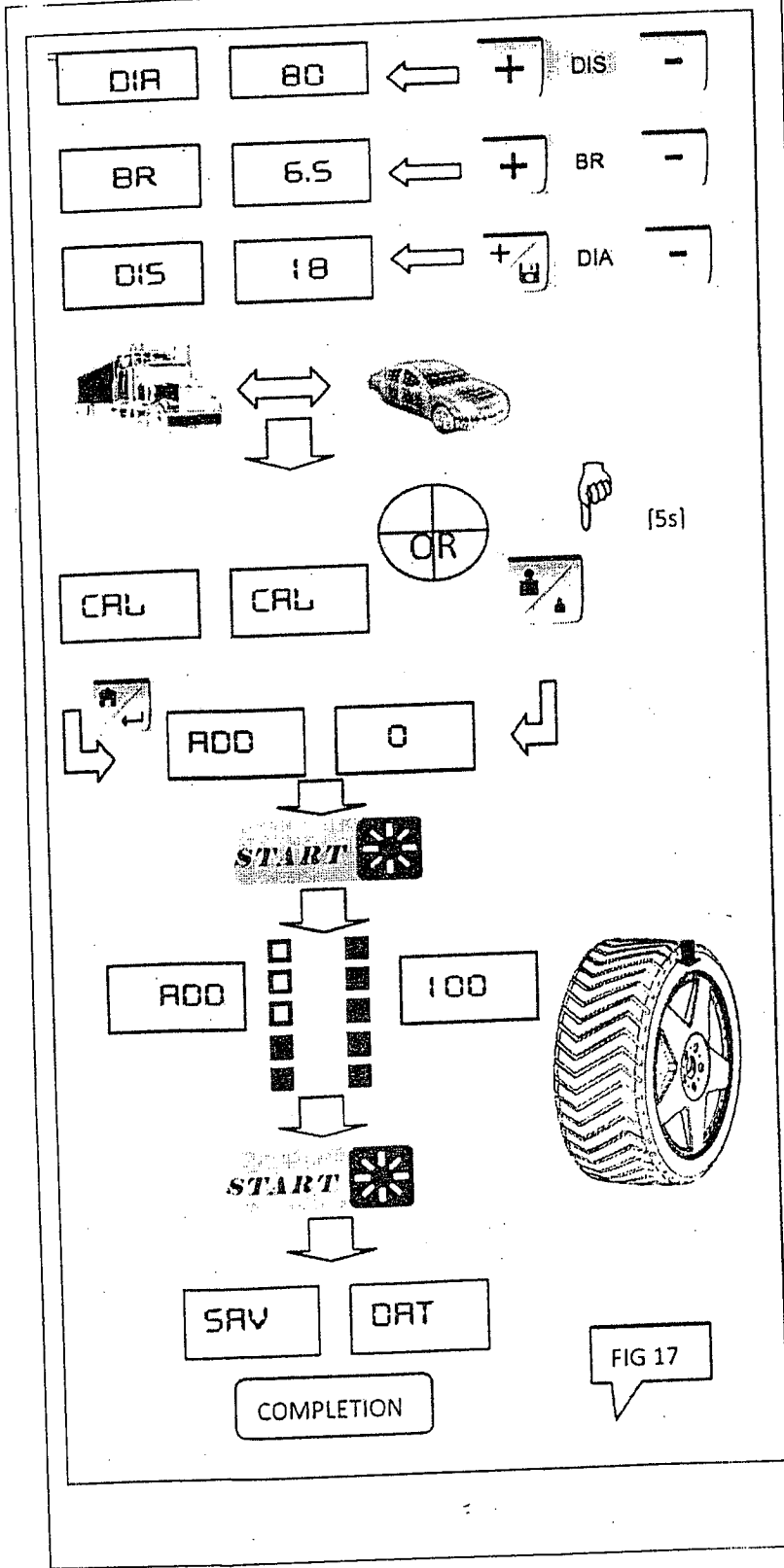



FIG 17

Select a suitable tire with the small unbalance value and mount it on the main shaft and input the parameter of the rim correctly.

Car mode and truck mode must be self-calibrated separately.

Refer to the FIG9, press the key to enter the program of [ CAL]-[ CAL] and then press  to enter the self-calibration[ ADD]-[ 0 ] to enter the self-calibration and input the parameter to select the mode os car or truck. Press and hold on  for 5 seconds and enter[ ADD]-[ 0 ]

According to the display start for one time without adding the weight to measure.

Spin the tire until the entire outer indication lamp light up. Add 100g of weight at the 12clock position outside and re-spin to measure.

After calibration, the machine will display [ SAV]-[ DAT ] and the program will automatically save and exit.

Complete the weight self-calibration.

## PIEZOELECTRICITY INSTALLATION AND CABLE

## SENSOR

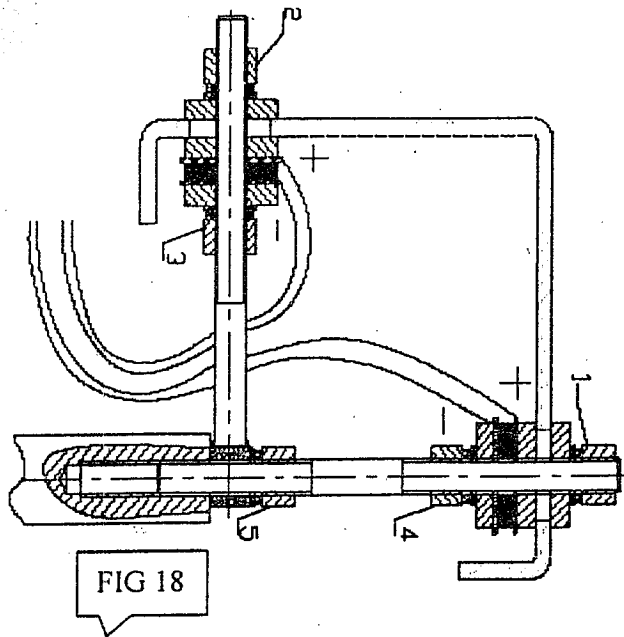

Sometimes, inaccurate balance or incorrect position is caused by the breakage of the press sensor. The changing method of the sensor is as following:

- (1) Remove the upper cover and the right side panel of the balancer.
- (2) Detach the nut1 and 2, elastic washer, plain washer and large flat washer.
- (3) Loose the back nut3.4.5 to detach every parts.
- (4) Change the new sensors and tight the dual-head screw and then tight nut 5. The installation of the negative and positive pole of the piezoelectric ceramics disk of the sensor must follow the picture.
- (5) Use the spanner to tight the nut4 and then nut 3. At this moment, you should pay attention to the horizontal and vertical sensor screws should be vertical. And the end of the screws should be just fallen into the 2 holes. Mount the nut1 and 2, elastic washer, plain washer and large flat washer and completely tight them. Usually, lock nut 1 and then nut 2. We require to flat the elastic washer and then return the nut 1/4—1/2turn. Use this way to get the normal

pre-pressure of the press sensor (use torque wrench to lock and the torque is 40NM) There are glass glue coat on the surface of the press sensor and the normal installation result of the piezoelectric ceramics disk of the sensor is the IR should be larger than 50MΩ.

(6) Discharge the output line of the shortcuts press sensor. Insert into the computer board after discharge to avoid the breakage of the computer board.

(7) Insert the vertical (⊥) & horizontal (//) sensor plugs according to the original position.





(8) Calibrate the balancer again and install the upper cover and the side panel after check result is normal.

(9) After change the computer board, phase sensor or the pressure sensor, it must self-calibrate.

## TROUBLESHOOTING AND ITS SOLUTION

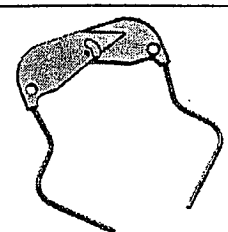
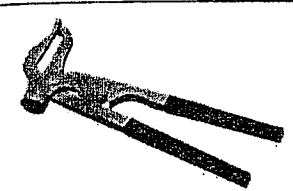
No	Description	Cause	Solution
1	Start the machine but not display or the main switch indicating lamp not light	<ol style="list-style-type: none"> <li>1. Socket fault</li> <li>2. power board fault</li> <li>3. The cable between the power board &amp; main board come off</li> <li>4. computer board fault</li> </ol>	<ol style="list-style-type: none"> <li>1. Check the power supply circuit, plug and socket</li> <li>2. Change the power board</li> <li>3. Connect the main board cable and reconnect and fix</li> <li>4. Change the computer board and recalibrate</li> </ol>
2	Display is normal but the start button and input push button not working.	<ol style="list-style-type: none"> <li>1. contact switch not good</li> <li>2. machine breakdown</li> </ol>	<ol style="list-style-type: none"> <li>1. Check the control panel cable.</li> <li>2 Switch on the machine again.</li> </ol>
3	display[0]-[0] without the other value display	<ol style="list-style-type: none"> <li>1. sensor cable come off</li> <li>2. computer board program fault</li> </ol>	<ol style="list-style-type: none"> <li>1. Check the piezoelectricity sensor cable.</li> <li>2. Change the computer board and recalibrate.</li> </ol>
4	Not brake after start or display ERR -sp	photocell sensor troubleshooting	Check is the POS is active through test. If it is active, check the photocell sensor and change if there is problem.
5	When start, the wheel cannot spin	Check the program setup to see if the hood monitor	In the program setup, set the [-P-] to be [OFF] and without using of the monitor or lower down the machine hood.
6	The wheel clip the weight for many times bur cannot balance the tire	The machine has not been used for a long time or the machine was bump.	So the weight self-calibration according to the FIG 17 .
7	The unbalance display of the wheel balancer is not stable.	<ol style="list-style-type: none"> <li>1. The machine affected by the vibration when rotating.</li> <li>2. The place of the machine is not stable.</li> <li>3. The wheel is not clamped firmly.</li> <li>4. The input of the data is not correctly.</li> <li>5. The machine is not calibrated.</li> </ol>	<ol style="list-style-type: none"> <li>1. Repeat the operation</li> <li>2. Avoid the vibration when accessing the value.</li> <li>3. Place the machine stable and clamp the wheel properly.</li> <li>4. Input the correct value.</li> <li>5 Make calibration.</li> </ol>
8	After clamping the tire which has be balanced, the test data will be larger.	<ol style="list-style-type: none"> <li>1. The link between the thread shaft and the main shaft is not clean when mount.</li> <li>2 There is impurity on the main shaft and or the flange.</li> </ol>	<ol style="list-style-type: none"> <li>1. Clean the link between the thread shaft and the main shaft and re-rotate and fix.</li> <li>2 Clean the impurity.</li> </ol>

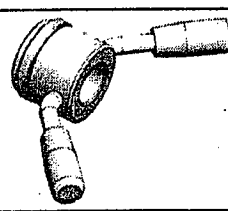
## WHEEL BALANCER ACCESSORY

Standard accessory					
Accessory	Name	Quantity	Accessory	Name	Quantity
	Cone/ flange disk	1 set		Br scale	1 piece
	pliers	1 piece		thread shaft	1 piece
	Quick nut	1piece		weight	1piece

### MAINTENANCE



Warning

The manufacturer will not bear any responsibility if the problems are caused by the application of the unoriginal spare parts and accessories.



Warning

Pull out the power plug and secure all the movable parts are locked before the execution of the adjustment and maintenance.



Warning

Do not remove or improve any part of the machine.



Cause

Keep the working area clean.

Never use the compressed air /water water spray to remove the dust and residual on the machine. Prevent the coming of the dust in the process of the operation.

Keep the clean of the balance shaft, nut, cone and the flange. Use the brush rinsed in the neutral solution to

clean these parts.

Carefully operate the cone and flange to avoid the accident fall and the following damage. Its result is the influence on the accuracy of the centering. Place the cone and flange in the condition of dust-proof. If necessary, use the ethanol to clean.

Make the calibration once per 6months.

### LUBRICATION

Greasing the wheel balancer

The only rotating parts of the wheel balancer are the motor and the balancing shaft, so the bearing of these components must be checked periodically by the operator and greased. If the machine is used frequently (more than two hours per day), check the bearing every year; if the machine is not used so often, the check can be made every two years. The bearing cannot be opened for the test, so insert a screwdriver and check the sound produced. As the bearing acts as a clamping support, it is not easy to change or take out the grease.



In addition, the rotation speed is not high for the machine, so it is not necessary to change the grease. If you notice an incorrect working or a noisy bearing, replace the bearing. If the customer confirms that the bearing has not been replaced, just change the grease, then disassemble the bearing, open the dust guard ring and add the grease (XHP103), carrying out these operations under the guidance of a professional. Calibrate the machine after replacing the bearing. If the operation has not been carried out correctly, the machine precision will be affected, so reposition the dust guard ring, reassemble the machine and repeat the adjustment.

Technical safety card for using grease in the wheel balancer

Mobilgrease XHP	103
NLGI degree	3
Type of thickener	Li-complex
Colour, appearance	Dark blue
Penetration on the processed item 25°, ASTM D 217, mm/10	235
Dropping point, °C, ASTM D 2265	280
Viscosity oil base, ASTM D 445, cSt @ 40°C	100
Change of penetration consistency, ASMT D 1831 (established upon the rolling of the greases), mm/10	10
4 spheres test, impression diam., ASTM D 2266, mm	0.5
4 spheres test, welding load, ASTM D 2509, kg	315
Test Timken OK load, ASTM D 2509, lb	45
Stability of oxidisation bomb method, ASTM D 942, pressure drop at 100 hours, kPa	35
Corrosion prevention, ASTM D 1743	Passed
Emcor rust, IP 220, wash away with acid water	0

Rust protection; IP 220-mod, wash away with distilled water	0
Corrosion on copper, ASTM D 4048	1A
Resistance to water spray, ASTM D 4049, % spray	15
Wash away with water, ASMT D 1264, loss (weight%), @ 79°C	5

### SCRAPPING

If the machine is to be scrapped, separate all electrical, electronic, plastic and ferrous components and dispose of them separately, as provided for by local regulations in force.

If the machines have the crossed-out bin symbol on



their data plate , the following disposal procedure must be applied to.

This product may contain substances that can be hazardous to the environment and to human health if it is not disposed of properly.

Electrical and electronic equipment must never be disposed of in the usual municipal waste but must be separately collected for their proper treatment.

The crossed-out bin symbol , placed on the product and on this page, reminds the user that the product must be disposed of properly at the end of its life.

Thus, the hazardous consequences that non-specific treatments of the substances contained in these products, or improper use of parts of them, may have on the environment or on human health are prevented. Furthermore, this helps to recover, recycle and reuse many of the materials contained in these products.

Electrical and electronic manufacturers and distributors set up proper collection and treatment systems for these products for this purpose.

Contact the collector product.

When purchase inform you piece of equivalent purchase

Any disposal way from penalties force in

Further recommendations packa batter

Your resolution elect prod prev bein

Cor fire

Dry

Wa

Fo

Po

CC

YE

L

T

g

e

r

Contact your local distributor to obtain information on the collection procedures at the end of the life of your product.

When purchasing this product, your distributor will also inform you of the possibility to return another end-of-life piece of equipment free of charge as long as it is of equivalent type and had the same functions as the purchased product.

Any disposal of the product performed in a different way from that described above will be liable to the penalties provided for by the national regulations in force in the country where the product is disposed of.

Further measures for environmental protection are recommended: recycling of the internal and external packaging of the product and proper disposal of used batteries (only if contained in the product).

Your help is crucial to reduce the amount of natural resources used for manufacturing electrical and electronic equipment, minimize the use of landfill for product disposal and improve the quality of life, preventing potentially hazardous substances from being released in the environment.

#### FIREFIGHTING MEANS TO BE USED

Consult the following table to choose the most suitable fire extinguisher.

Dry materials		Flammable liquids		Electrical equipment	
Water	YES	Water	NO	Water	NO
Foam	YES	Powder	YES	Foam	NO
Powder	YES*	Powder	YES	Powder	YES
CO2	YES*	CO2	YES	CO2	YES

YES\* Use only if more appropriate extinguishers are not at hand or when the fire is small.



Warning

This table contains general instructions to be used as guidelines for users. All the applications of each type of extinguisher must be obtained from the relevant manufacturer.

ATTACHMENT | 3 phase power board cable diagram

ATTACHMENT

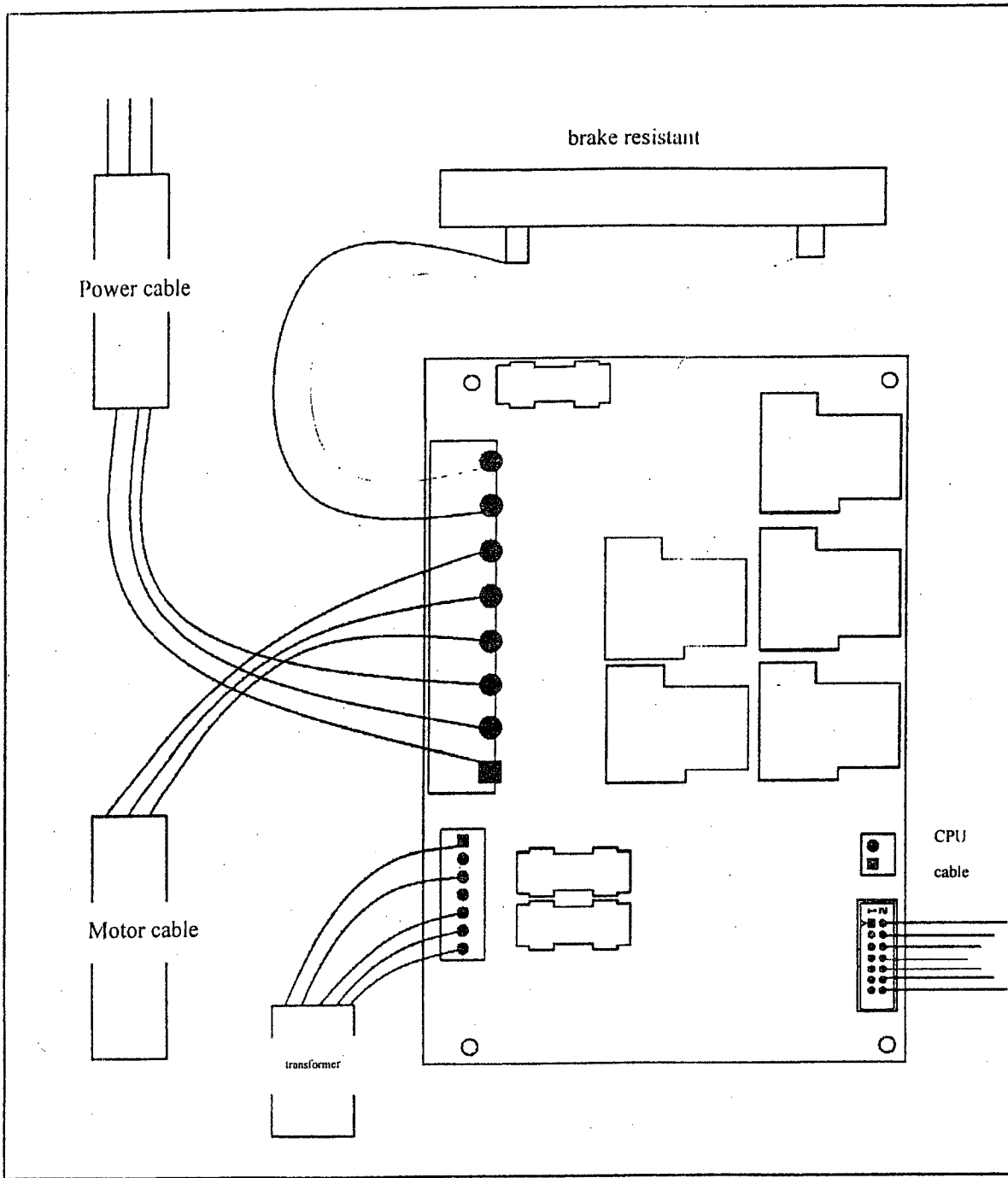

ATTACHMENT II Single phase power board cable diagram

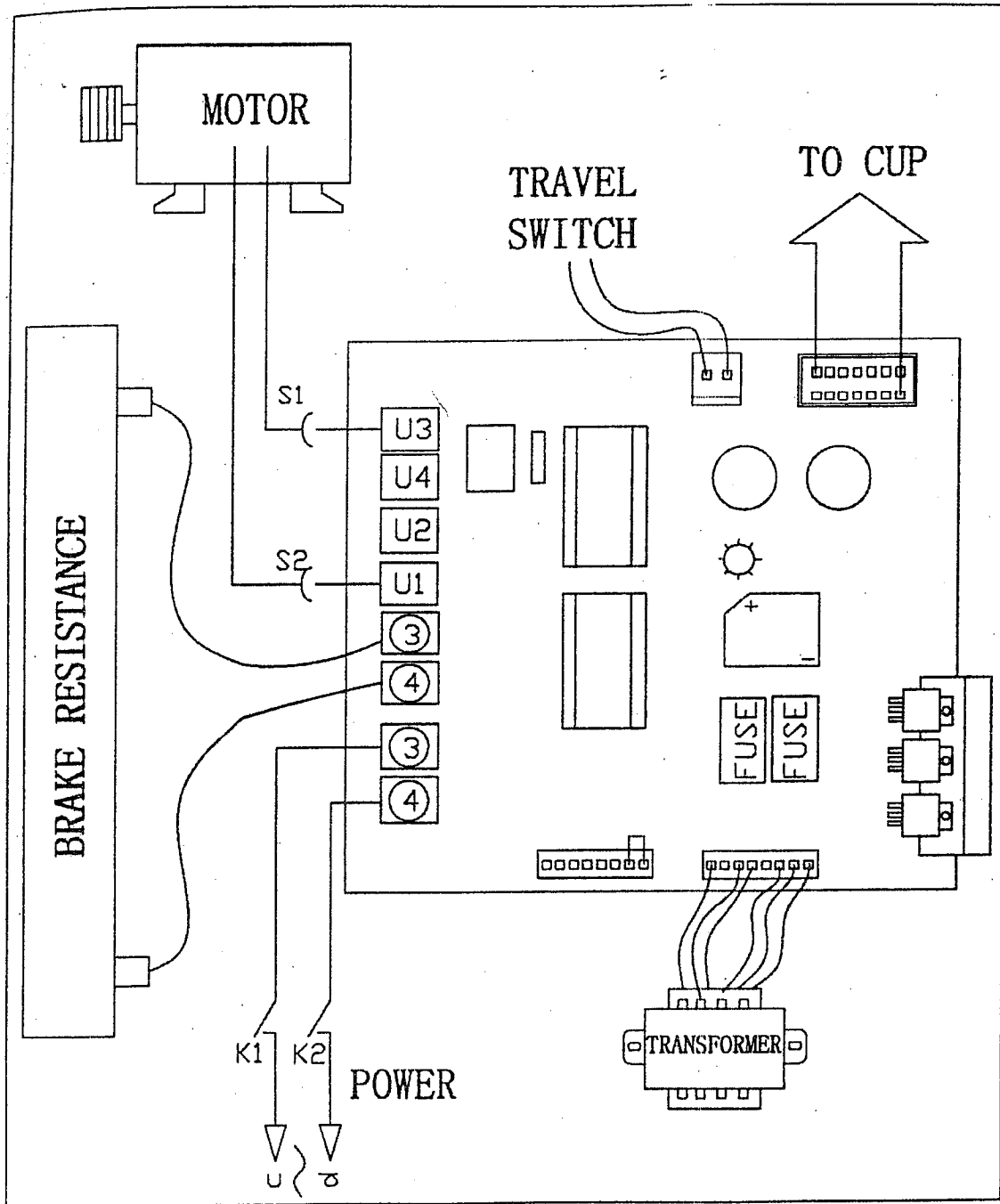

ATTACHMENT III Electrical theory diagram

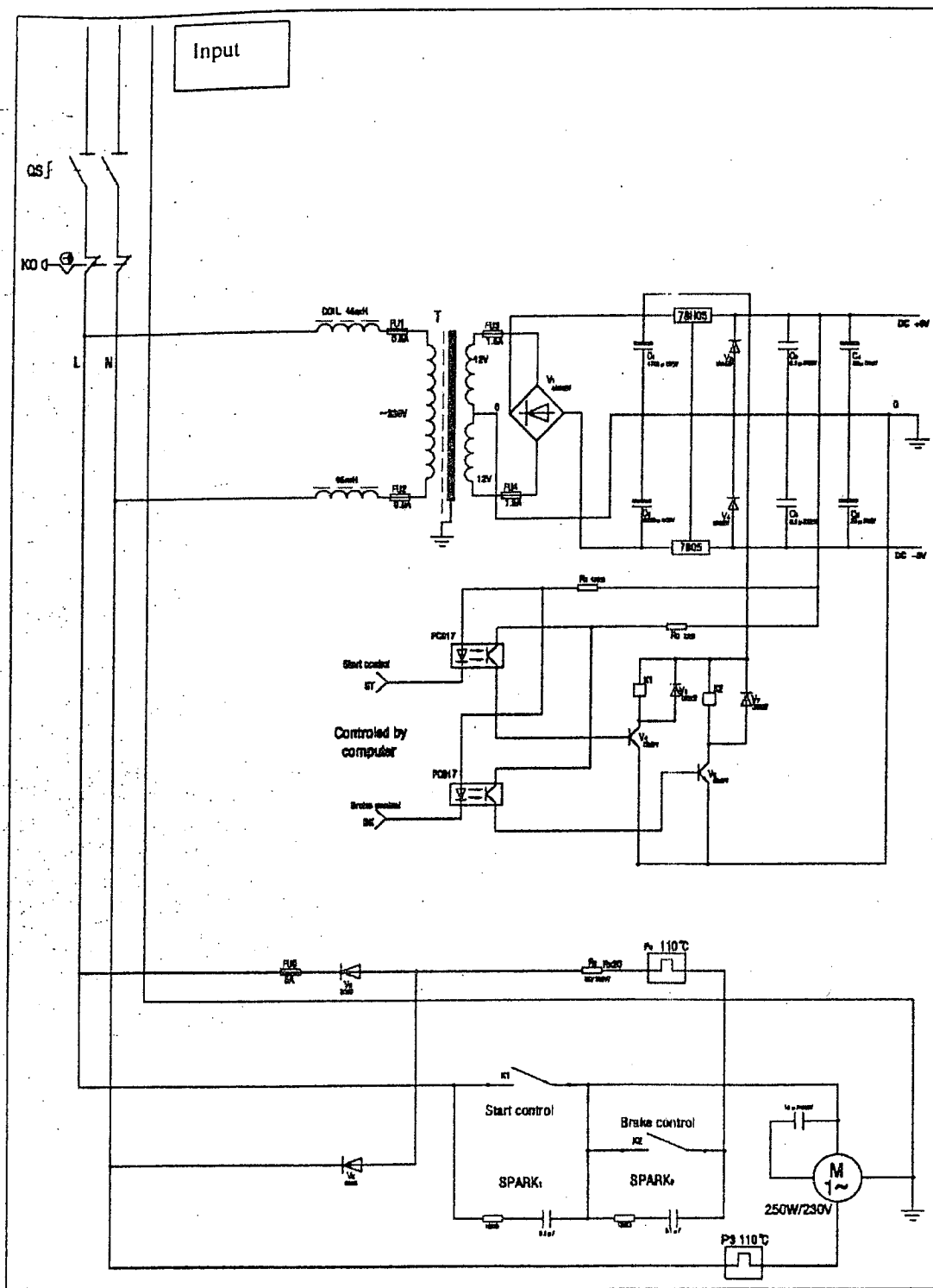

The pictures of the machine and drawings in the instruction manual are only as reference. manufacture is subject to change without notice.