

## Foam Chambers

### Features

- Choice of four foam chamber sizes for various foam solution flow rate requirements
- Hinged inspection hatch with captive bolt securement for ease of inspection and maintenance
- Choice of carbon steel or 304 stainless steel with corrosion resistant (CR) epoxy paint finish
- TEFLON\* vapor seal allows unrestricted flow of expanded foam
- Convenient vapor seal replacement without removal of retaining bolts
- UL Listed

### Application

CHEMGUARD foam chambers are air-aspirating foam discharge devices that are used to protect various types of flammable liquid storage tanks including open top floating roof tanks and cone roof tanks with or without internal floaters. Additional applications include most types of open tanks where flammable liquid products are involved.

Foam chambers are defined by NFPA 11 as Type II discharge outlets for delivering foam to the surface of a flammable liquid. They are commonly used with bladder tanks, balanced pressure pump proportioning systems, line proportioners, or foam trucks. These foam chambers can be used with CHEMGUARD low-expansion foam agents that are determined to be suitable for the flammable liquid being protected.

### Description

The CHEMGUARD foam chambers consist of a foam expansion chamber and an integral foam maker with a stainless steel screened air inlet. Each chamber includes an orifice plate, two inlet gaskets, vapor seal assembly, cover gasket, and an outlet gasket. The required deflector (split or shallow) and optional mounting pad assembly are sold separately.

A removable orifice plate located at the flanged inlet to the foam maker is sized to deliver the required flow rate of foam solution at a specified inlet pressure. A frangible TEFLON vapor seal is burst upon entry of foam solution allowing an unrestricted flow of expanded foam into the chamber body. From the chamber body, the foam flows through the foam deflector which disperses the foam into the storage tank.

The chamber vapor seal is accessible for inspection and service through a hinged inspection hatch that is secured with captive bolts. The hatch also contains a lifting handle that is designed to support the weight of the foam chamber.



009144

The foam deflector directs the foam stream down the tank side-wall to lessen the submergence of the foam and agitation of the fuel surface (Type II application). The foam deflector is a split (two-piece) style. The split deflector allows for either bolting or welding to storage tanks when installation may be performed from both sides of the tank wall as with newly constructed tanks. The split deflector also allows for insertion of the deflector through the flange opening from the outside wall as is often required with tanks already in service.

The foam chamber and deflector can be bolted to the storage tank using a mounting pad. The pad contains mounting studs to fit standard flange holes.

### Flow Range

The flow rate of the foam chamber is determined by the orifice size and the inlet pressure. The flow ranges listed in the following table are based on 40 psi (2.76 bar) using the smallest orifice for the minimum flow and 100 psi (6.9 bar) using the largest orifice for the maximum flow.

Model	Typical Flow Range	K-Factor Range
CGFC-90	49 gpm to 151 gpm (185 Lpm to 572 Lpm)	7.8 to 15.1
CGFC-170	94 gpm to 279 gpm (356 Lpm to 1,056 Lpm)	14.9 to 27.9
CGFC-330	183 gpm to 610 gpm (693 Lpm to 2,309 Lpm)	28.9 to 61.0
CGFC-550	350 gpm to 980 gpm (1,325 Lpm to 3,709 Lpm)	55.3 to 98.0

UL Listed flow ranges vary by foam concentrate – consult the UL Online Certifications Directory for agent-specific flow ranges. To determine flow rates for specific applications and proper orifice sizing, consult Tyco Fire Protection Products Technical Services.

## Specifications

The foam chamber assembly shall consist of a chamber body with an integral foam maker and orifice plate. Each chamber shall include an orifice plate, two inlet gaskets, vapor seal assembly, cover gasket, and an outlet gasket. A foam deflector and foam chamber mounting pad shall be available for use with the assembly as required.

The foam chamber body shall be of steel construction with a CR epoxy finish. The discharge outlet shall be of the flat faced flange design that may be welded or bolted to the storage tank. For ease of access to the vapor seal, the chamber body shall contain a hinged inspection hatch secured with stainless steel captive bolts. The hatch shall also contain a lifting handle designed to support the weight of the chamber for hoisting.

The foam maker shall contain a stainless steel screen that is cylindrically shaped to conform to the air inlet surface to help prevent damage. The vapor seal shall be of TEFLON construction to allow an unrestricted flow. The TEFLON vapor seal shall be designed of a thickness to meet the UL required flowing foam solution burst pressure range of 10 psi to 25 psi (0.69 bar to 1.72 bar). The vapor seal retainer shall be designed with slotted keyholes to eliminate bolt removal during replacement. The inlet to the foam maker shall be a raised face flange with an orifice sized to allow the required flow rate of foam solution at the available pressure.

A split foam deflector shall be provided for either bolting or welding to the mounting surface, or for installation from the outside wall of the storage tank. For bolting applications, a mounting pad shall be available with a stud pattern compatible with the flat-face flange of the foam chamber body and the foam deflector.

A stainless steel nameplate shall be attached to the foam chamber hatch. The nameplate shall specify manufacturer, model number, and part number.

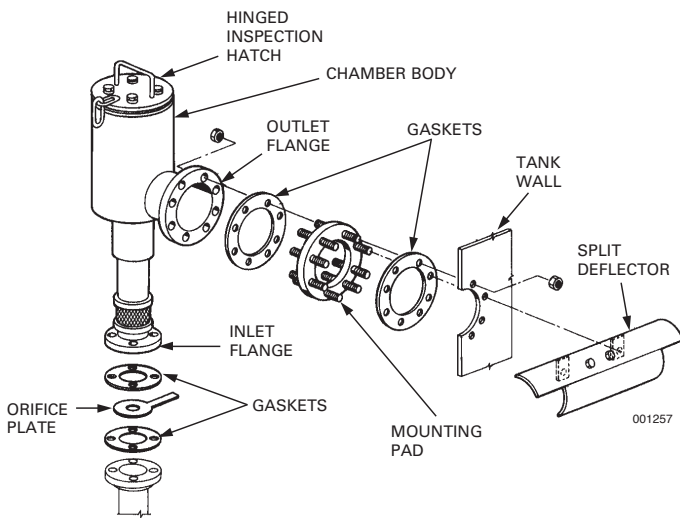

## Dimension Table

Dimension	CGFC-90	CGFC-170	CGFC-330	CGFC-550
A	26 1/16 in. (662 mm)	31 7/8 in. (810 mm)	35 3/8 in. (899 mm)	42 in. (1,067 mm)
B	15 5/16 in. (389 mm)	19 5/8 in. (498 mm)	20 5/8 in. (524 mm)	24 3/4 in. (629 mm)
C	8 1/2 in. (216 mm)	10 in. (254 mm)	11 1/8 in. (283 mm)	12 3/8 in. (314 mm)
D	8 5/8 in. (219 mm)	10 3/4 in. (273 mm)	12 3/4 in. (324 mm)	16 in. (406 mm)
E	7 in. (178 mm)	9 in. (229 mm)	10 in. (254 mm)	12 in. (305 mm)
F <sub>i</sub>	2 1/2 in. (64 mm)	3 in. (76 mm)	4 in. (102 mm)	6 in. (152 mm)
F <sub>o</sub>	4 in. (102 mm)	6 in. (152 mm)	8 in. (203 mm)	10 in. (254 mm)
G	3 1/4 in. (83 mm)	4 1/16 in. (103 mm)	5 in. (127 mm)	6 7/8 in. (175 mm)
H	5 5/16 in. (135 mm)	7 3/8 in. (187 mm)	9 1/8 in. (231 mm)	9 3/4 in. (248 mm)
I	8 in. (203 mm)	9 1/2 in. (241 mm)	11 in. (279 mm)	12 in. (305 mm)
J	4 5/8 in. (117 mm)	6 1/8 in. (156 mm)	7 3/4 in. (197 mm)	8 1/4 in. (209 mm)
K	8 in. (203 mm)	12 in. (305 mm)	16 in. (406 mm)	20 in. (508 mm)
L	12 in. (305 mm)	18 in. (457 mm)	24 in. (610 mm)	30 in. (762 mm)
M	4 1/2 in. (114 mm)	6 5/8 in. (168 mm)	8 5/8 in. (219 mm)	10 3/4 in. (273 mm)
N	7 1/2 in. (191 mm)	9 1/2 in. (241 mm)	11 3/4 in. (298 mm)	14 1/4 in. (362 mm)
O	3/4 in. (19 mm)	7/8 in. (22 mm)	7/8 in. (22 mm)	1 in. (25 mm)
P	2 7/8 in. (73 mm)	3 1/2 in. (89 mm)	4 1/2 in. (114 mm)	6 5/8 in. (168 mm)
Q	5 1/2 in. (139 mm)	6 in. (152 mm)	7 1/2 in. (191 mm)	9 1/2 in. (241 mm)
R	3/4 in. (19 mm)	3/4 in. (19 mm)	3/4 in. (19 mm)	7/8 in. (22 mm)
S	8 1/2 in. (216 mm)	12 in. (305 mm)	16 in. (406 mm)	20 in. (508 mm)
T	14 1/2 in. (368 mm)	16 in. (406 mm)	24 1/2 in. (622 mm)	23 1/4 in. (590 mm)
U	1 1/2 in. (38 mm)	1 1/2 in. (38 mm)	1 1/2 in. (38 mm)	3 5/16 in. (84 mm)
V	6 15/16 in. (176 mm)	8 25/32 in. (223 mm)	10 27/32 in. (275 mm)	13 3/4 in. (349 mm)
W	4 5/16 in. (110 mm)	4 11/16 in. (119 mm)	5 3/4 in. (146 mm)	7 5/32 in. (182 mm)

OUTLET FLANGE - FLAT FACE (FO DETAIL)

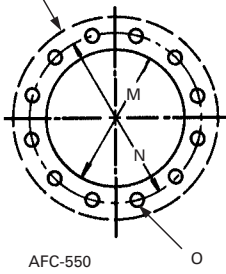

AFC-550

OUTLET FLANGE - FLAT FACE (FO DETAIL)

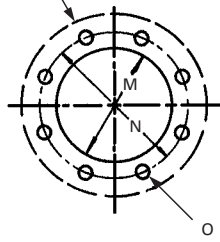

AFC-90, AFC-170, AFC-330

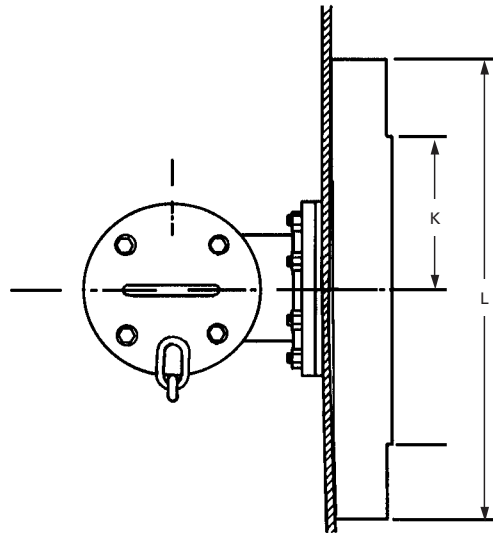

002158

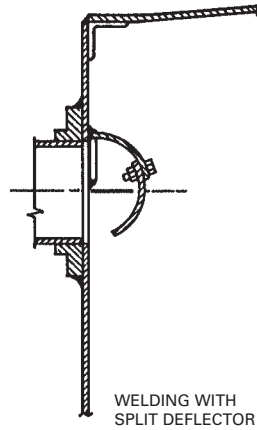
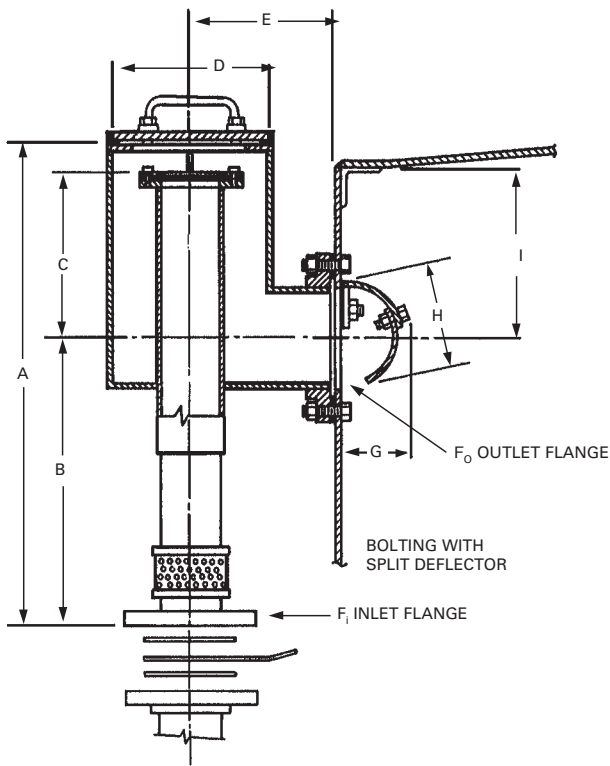

WELDING WITH SPLIT DEFLECTOR

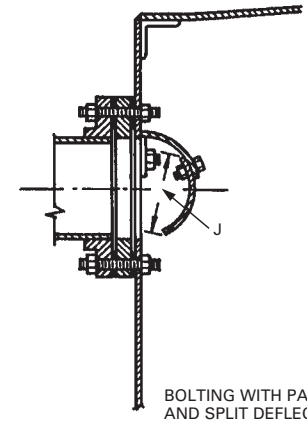

BOLTING WITH PAD AND SPLIT DEFLECTOR

009146

INLET FLANGE (F, DETAIL) - RAISED FACE

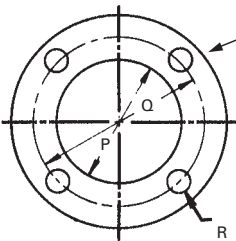

AFC-90, AFC-170

INLET FLANGE (F, DETAIL) - RAISED FACE

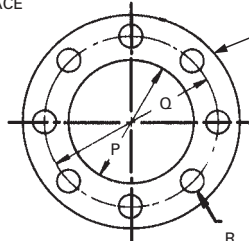

AFC-330, AFC-550

001260

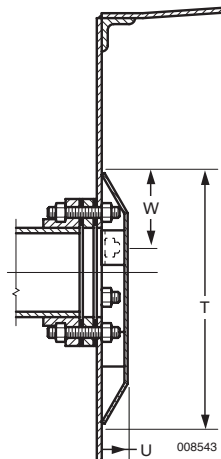

BOLTING WITH SHALLOW DEFLECTOR

008543

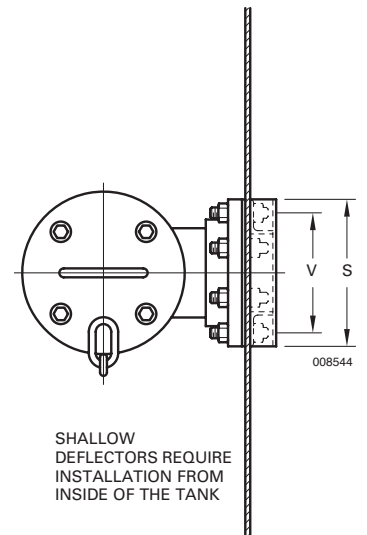

008544

**Note:** The inlet and outlet flanges are designed to mate with ANSI 150 lb class flanges.

## Ordering Information

### Foam Chambers

Part No.	Description	Approximate Shipping Weight	
		lb	(kg)
702660	Foam Chamber/Maker, CGFC-90, Carbon Steel, CR Epoxy Red	60	(27.2)
704058	Foam Chamber/Maker, CGFC-90, 304SS, CR Epoxy Red	60	(27.2)
74376	Split Deflector, 90 Size, Carbon Steel, Primed	5	(2.3)
428637	Shallow Deflector, 90 Size, Carbon Steel, Primed**	5	(2.3)
443200	Split Deflector, 90 Size, 304SS, Primed	5	(2.3)
443201	Shallow Deflector, 90 Size, 304SS, Primed**	5	(2.3)
702663	Foam Chamber/Maker, CGFC-170, Carbon Steel, CR Epoxy Red	100	(45.4)
704059	Foam Chamber/Maker, CGFC-170, 304SS, CR Epoxy Red	100	(45.4)
74380	Split Deflector, 170 Size, Carbon Steel, Primed	10	(4.5)
428638	Shallow Deflector, 170 Size, Carbon Steel, Primed**	10	(4.5)
443202	Split Deflector, 170 Size, 304SS, Primed	10	(4.5)
443203	Shallow Deflector, 170 Size, 304SS, Primed**	10	(4.5)
702666	Foam Chamber/Maker, CGFC-330, Carbon Steel, CR Epoxy Red	145	(65.8)
704060	Foam Chamber/Maker, CGFC-330, 304SS, CR Epoxy Red	145	(65.8)
74384	Split Deflector, 330 Size, Carbon Steel, Primed	20	(9.1)
428639	Shallow Deflector, 330 Size, Carbon Steel, Primed**	20	(9.1)
443204	Split Deflector, 330 Size, 304SS, Primed	20	(9.1)
443205	Shallow Deflector, 330 Size, 304SS, Primed**	20	(9.1)
702669	Foam Chamber/Maker, CGFC-550, Carbon Steel, CR Epoxy Red	270	(122.5)
704061	Foam Chamber/Maker, CGFC-550, 304SS, CR Epoxy Red	270	(122.5)
74388	Split Deflector, 550 Size, Carbon Steel, Primed	30	(13.6)
428640	Shallow Deflector, 550 Size, Carbon Steel, Primed**	30	(13.6)
443206	Split Deflector, 550 Size, 304SS, Primed	30	(13.6)
443207	Shallow Deflector, 550 Size, 304SS, Primed**	30	(13.6)

\*\* Shallow deflectors are a lower protrusion option than the standard split deflectors illustrated on Page 3. Shallow deflectors may be required for cone roof tanks with internal floaters where the protrusion of a split deflector interferes with the internal floater operation.

## Ordering Information (Continued)

### Foam Chamber Accessories

Part No.	Description	Approximate Shipping Weight	
		lb	(kg)
74390	Foam Chamber Mounting Pad, 90 Size, Carbon Steel, CR Epoxy Red	15.0	(6.80)
74394	Foam Chamber Mounting Pad, 170 Size, Carbon Steel, CR Epoxy Red	20.0	(9.07)
74398	Foam Chamber Mounting Pad, 330 Size, Carbon Steel, CR Epoxy Red	35.0	(15.88)
74402	Foam Chamber Mounting Pad, 550 Size, Carbon Steel, CR Epoxy Red	50.0	(22.68)
443208	Foam Chamber Mounting Pad, 90 Size, 304SS, CR Epoxy Red	15.0	(6.80)
443209	Foam Chamber Mounting Pad, 170 Size, 304SS, CR Epoxy Red	20.0	(9.07)
443210	Foam Chamber Mounting Pad, 330 Size, 304SS, CR Epoxy Red	35.0	(15.88)
443211	Foam Chamber Mounting Pad, 550 Size, 304SS, CR Epoxy Red	50.0	(22.68)
74408	Foam Chamber Diverter Test Tube, 90 Size	15.0	(6.80)
74412	Foam Chamber Diverter Test Tube, 170 Size	20.0	(9.07)
74416	Foam Chamber Diverter Test Tube, 330 Size	40.0	(18.14)
74420	Foam Chamber Diverter Test Tube, 550 Size	65.0	(29.48)

**Note:** Foam chambers, mounting pads, and foam deflectors are available in a *primed-only* finish on a special order basis. Lead times on stainless steel foam chambers may be longer than carbon steel versions. Contact Tyco Fire Protection Products Technical Services for additional information.

### Foam Chamber Spare Parts

418581	Foam Chamber Vapor Seal Assembly, 90 Size	0.5	(0.23)
418582	Foam Chamber Vapor Seal Assembly, 170 Size	0.5	(0.23)
418583	Foam Chamber Vapor Seal Assembly, 330 Size	0.5	(0.23)
418584	Foam Chamber Vapor Seal Assembly, 550 Size	0.5	(0.23)
75985	Foam Chamber Cover Gasket, 90 Size	0.3	(0.14)
75986	Foam Chamber Cover Gasket, 170 Size	0.3	(0.14)
75987	Foam Chamber Cover Gasket, 330 Size	0.3	(0.14)
75988	Foam Chamber Cover Gasket, 550 Size	0.3	(0.14)
74610	Foam Chamber Orifice Plate, 90 Size	1.0	(0.45)
74611	Foam Chamber Orifice Plate, 170 Size	1.0	(0.45)
74612	Foam Chamber Orifice Plate, 330 Size	1.0	(0.45)
74613	Foam Chamber Orifice Plate, 550 Size	1.0	(0.45)
75968	Foam Chamber Cover Screw, All Models	0.3	(0.14)

**Note:** The converted metric values in this document are provided for dimensional reference only and do not reflect an actual measurement.

\*TEFLON is a trademark of its respective owner.

CHEMGUARD and the product names listed in this material are marks and/or registered marks. Unauthorized use is strictly prohibited.

