



LEADERS IN BOTANICAL EXTRACTIONS

PROFESSIONAL.
CERTIFIED.
SAFE.

WWW.ILLUMINATEDEXTRACTORS.COM



Copyright © YEAR OF FIRST PUBLICATION - 2017 ILLUMINATED EXTRACTORS, LTD

Ownership of copyright 2018

The copyright in these materials and for the website (including without limitation the text, computer code, artwork, photographs, images, music, audio material, video material and audio-visual material on the website) is owned by ILLUMINATED EXTRACTORS, LTD and its licensors. The equipment listed on these materials is proprietary knowledge and contains information that is currently PATENT PENDING.

ILLUMINATED Extractors

All E-4k Systems are 100% Propane (PHO) and Butane (BHO) Compatible

Illuminated Extractors current models have received professional engineer certifications for safety and are certified for use in the following states:

1. Colorado
2. California
3. Nevada
4. Oregon
5. Washington
6. Pennsylvania
7. Maryland

FOR STATES NOT LISTED:
At this time no regulatory framework
is in place and therefore no
certification is currently required.

ILLUMINATED Extractor Current Product Offerings

Essential-4k Base Model (Model# 106-YYYYMM###)

Base Model Price: \$19,800.00

Included with the Base model:

- User Manual & Copy of Certification
- Custom Stand(s)
- Oil Separator / Gas Dryer (with 3A Seive)
- Supply Tank
- Clamps & Hoses
- Non-jacketed (regular) Columns: 3" x 36" 2Lb (x2)
- Base Extractor
- Haskel EXT-420

**With this base model, operators will need to heat the basin to maintain efficiency (crock-pot method).*

This model was designed for smaller operations requiring simple extraction processes and techniques.

Products that can be created with this system include:

- Honeycomb / Wax
- Shatter
- Budder
- Sugar
- THC / CBD Distillate



Essential-4k Midgrade Model (Model# 106-YYYYMM###-B)

Included with the Midgrade model:

- User Manual & Copy of Certification
- Custom Stand(s)
- Oil Separator / Gas Dryer (with 3A Seive)
- Supply Tank
- Clamps & Hoses
- Non-jacketed (regular) Columns: 3" x 24" 1Lb (x1); 3" x 36" 2Lb (x1); 4" x 36" 5Lb (x1) + Misc Sizes Available!
- Base Extractor w/ Jacketed Basin
- Polyscience Heating Recirculator
- Haskel EXT-420

Operating Conditions

Max Ambient Temp: 100°F

Max High Temp: 125°F

Max Low Temp: -4°F

Maximum Working Pressure: 350 psi

Rated Solvents: n-Butane, iso-Butane, and Propane

**Faster recovery time w/ jacketed basin; no mess operation, meaning the operator will not be required to heat the basin of the machine due to the thermal jacketed basin.*

This model was designed for commercial operations requiring advanced extraction processes and techniques.

Products that can be created with this system include:

- Honeycomb / Wax
- Shatter
- Budder
- Sugar
- THC / CBD Distillate

The Essential-4K is a dedicated hydrocarbon extraction system developed by Illuminated Extractors for the proper use of Butane and Propane solvents. To safely use LP Gas for extraction, our system was designed with a maximum working pressure of 350 psi. The design of the Essential-4K gives the user ultimate control of their extraction by allowing the artist to perform soak, flush, and "shower-head" extraction methods. Designed with a top supply, gravity-fed system, we took advantage of general physics to maintain a high flow extraction and simplicity of system operation.



Essential-4k Professional Model (Model# 106-YYYYMM###-C)

Included with the Professional model:

- User Manual & Copy of Certification
- Custom Stand(s)
- Oil Separator / Gas Dryer (with 3A Seive)
- Supply Tank
- Clamps & Hoses
- Jacketed Columns: 3" x 36" 2Lb (x2)
- Non-jacketed (regular) Columns: 3" x 36" 2Lb (x1) + 4" x 36" 5Lb (x1) + Misc Sizes Available!
- Cryo Extractor w/ Jacketed Basin
- Julabo Chilling Recirculator
- Julabo Heating Recirculator
- Haskel EXT-420

Fast recovery time + the ability to process and create "Live-Resin". *Turn Green to Gold with this model

This model was designed for large commercial operations requiring advanced extraction processes and techniques to produce multiple products.

Products that can be created with this system include:

- Honeycomb / Wax
- Shatter
- Budder
- Sugar
- Live-Resin
- Terp Sauce
- THC / CBD Distillate

HOW TO ENSURE A SAFE WORKING ENVIRONMENT WHEN HANDLING HYDROCARBONS

- A well-ventilated area.
- The absence of ignition sources within a radiant of 3 meters from the system.
- Wearing protective equipment (gloves, glasses) is also essential, as hydrocarbon refrigerants burn like HFCs.
- Making use of a simple leak detector, that is suitable for hydrocarbons (do not use standard leak detector).
- Hydrocarbon Recovery Machine: make sure that the machine is hydrocarbon friendly and that the electronics are sealed.

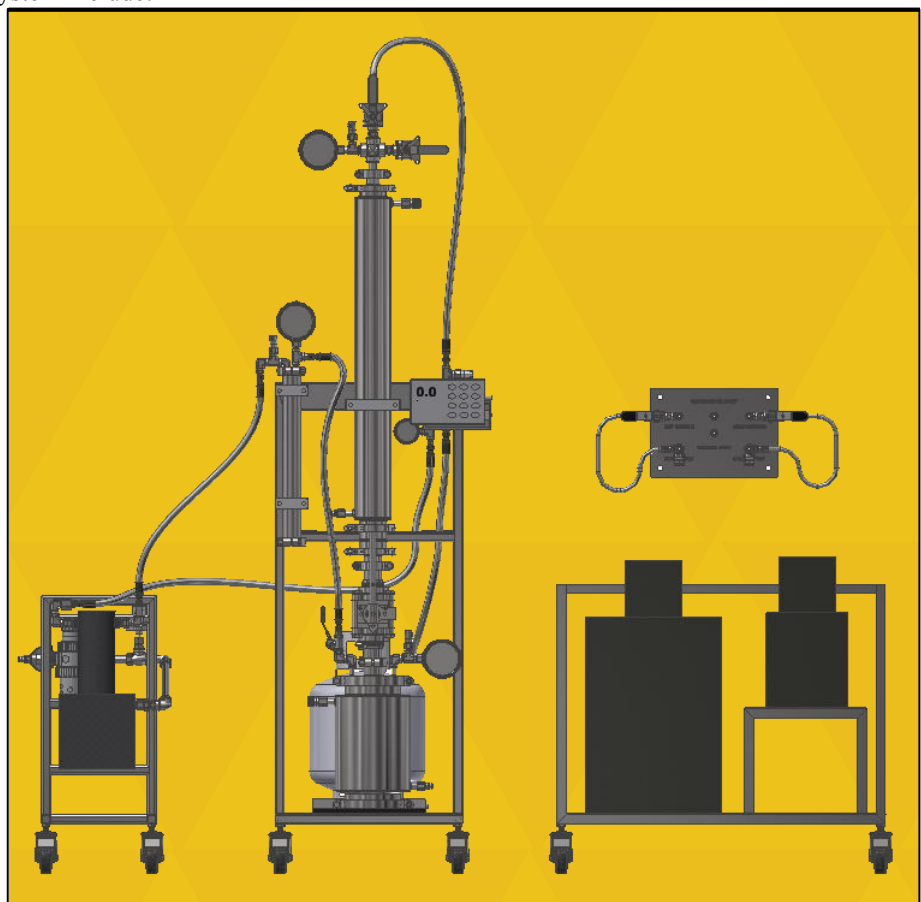

**Prices are "base values" which may be subject to sales tax.*



THE BEHEMOTH— THE 100 POUND UNIT

Please Call for Pricing

This model is essentially ten (10) of our E4k-Professional models put together as one single unit machine giving the user the ability to extract up to 100 pounds of material in a single run (est.). Available in 10 column (222.4 Liter), 5 column (111.2 Liter) or 3 column (67.2 Liter).

This model was designed for large-scale commercial operations requiring advanced extraction processes and techniques to produce multiple products.

Included with the Professional model:

- User Manual & Copy of Certification
- Custom Stand(s)
- Oil Separator
- Supply Tank
- Clamps & Hoses
- Jacketed Columns: 6" x 48" (x10)
- Non-jacketed (regular) Columns: 6" x 48" (x10)
- Jacketed De-waxing columns: 6" x 36" (x2)
- Cryo Extractor w/ Jacketed Basin
- Chilling Recirculator
- Heating Recirculator
- Haskel EXT-420 (x6)

Products that can be created with this system include:

1. Honeycomb / Wax
2. Shatter
3. Budder
4. Sugar
5. Live Resin
6. Terp Sauce
7. THC / CBD distillate
8. Sap

**Fast recovery time + the ability to process and create "Live Resin". *Turn Green to Gold with this Model*

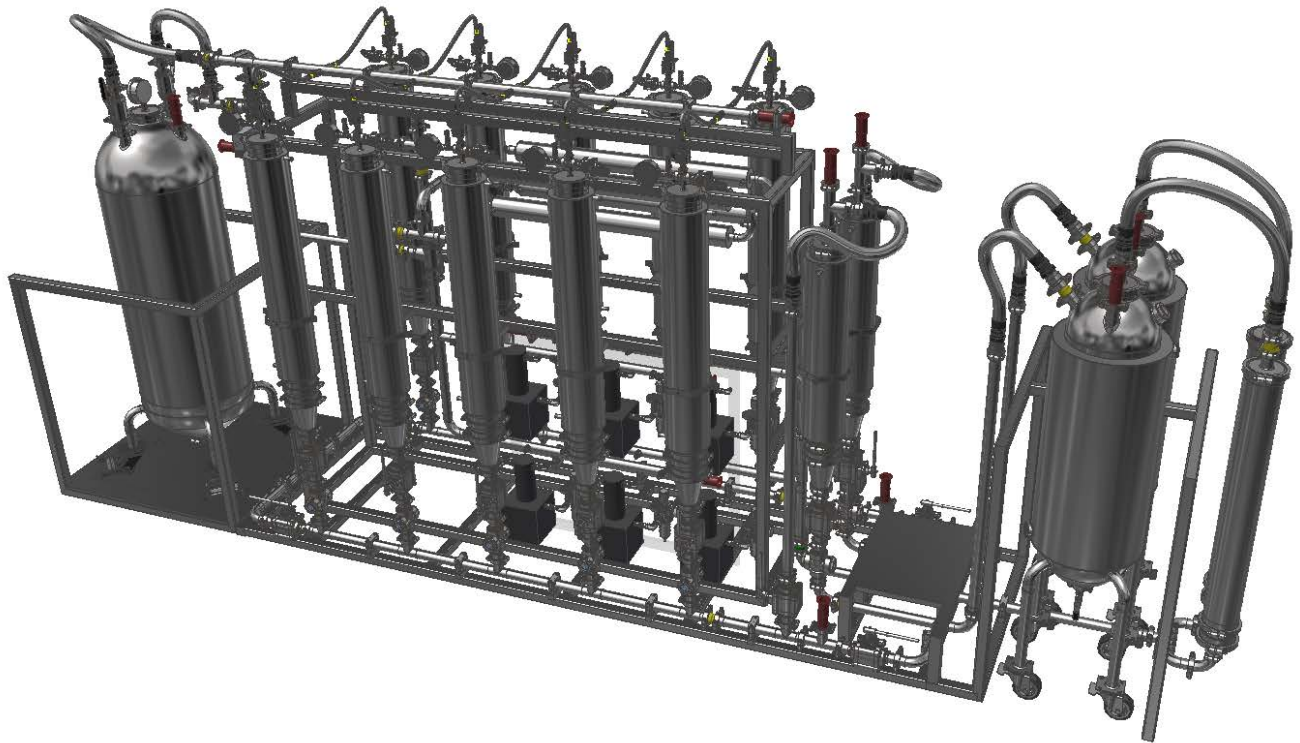

For more information please visit our website at www.illuminatedextractors.com or give us a call at (970)227-2564 to speak with one of our representatives.



Butane/Propane Distiller

All GD Systems are 100% Propane (PHO) and Butane (BHO) Compatible

Illuminated Extractors current models have received professional engineer certifications for safety and are certified for use in the following states:

1. Colorado
2. California
3. Nevada
4. Oregon
5. Washington
6. Pennsylvania
7. Maryland

FOR STATES NOT LISTED:
At this time no regulatory framework is in place and therefore no certification is currently required.

Gas Distiller 1.0 (Model# 109-YYYYMM###)

Included with this model:

- User Manual & Copy of Certification
- Custom Stand(s)
- Clamps & Hoses
- Vacuum Jacketed Rotary Evaporation Chamber
- Haskel EXT-420-2
- Ethanol Cleaning System
- CID1 Rated Drive Motor
- Made of PTFE & Stainless Steel
- Closed-Loop LP Gas Collection System
- +200°C Heat Circulation Pump

The GD-1 was designed to recover the majority of residual hydrocarbons (Butane or Propane) prior to vacuum oven purging or distillation.

Time spent in vacuum oven is greatly reduced due to the increased surface area created by the rollers.

This machine works in conjunction with both the E4k series extractors as well as the Roto-Still.

Products that can be made with this machine are:

- Oil
- Honeycomb / Wax
- THC / CBD Distillate (Vape Pens & Edibles)

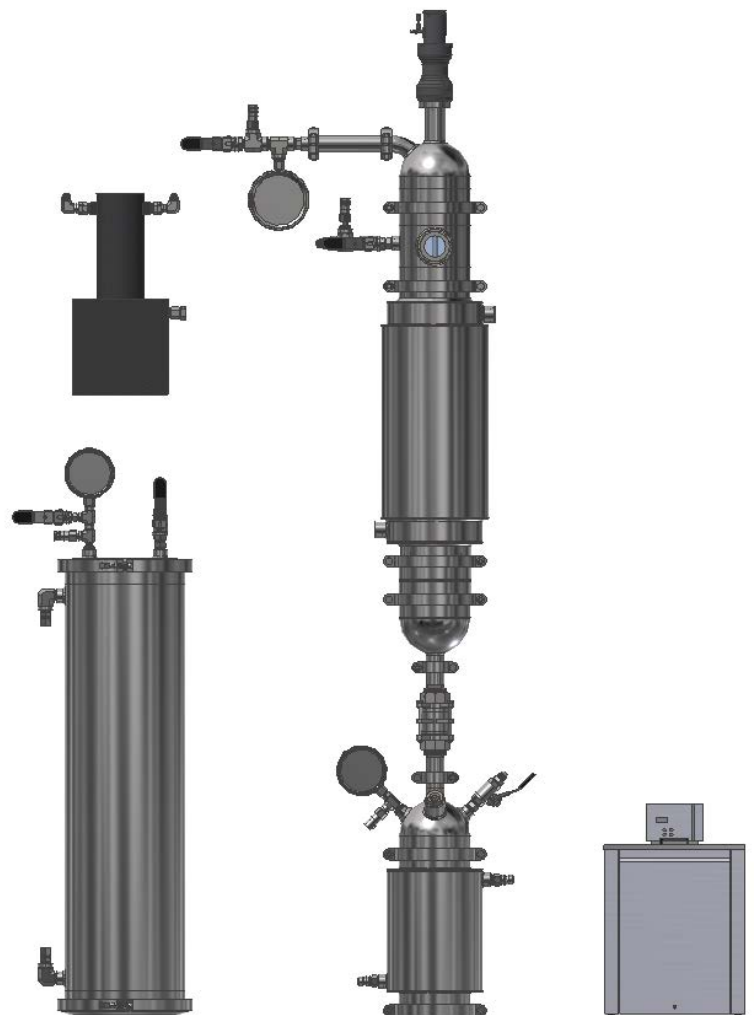

****Shown without hoses or stand**

The DaVinci Sensor

Special Introductory Price
of \$2,495.00

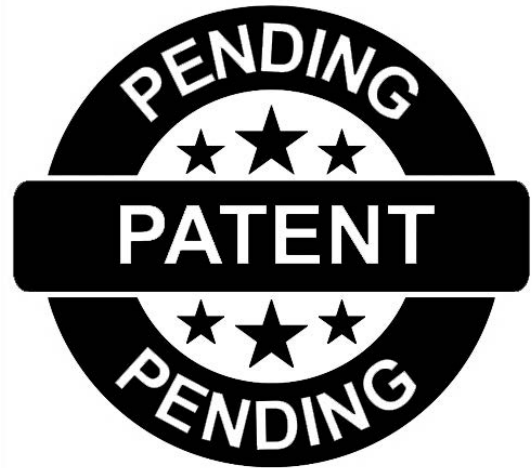
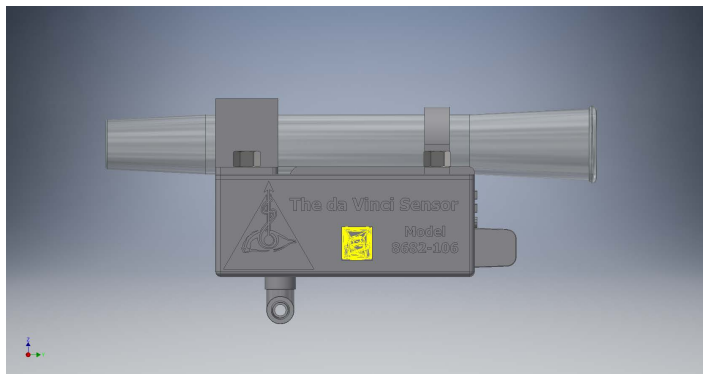

Short-Path Distillation Assistant Tool

Features & Benefits Included with this Sensor:

- Track Mantle & Head Probe Temperatures
- Ambient Sensor to Compensate for Vacuum Pressure
- Digital Vacuum Pressure Readout
- Light Sensor Sees 40 bit Color (719 Quadrillion Colors)
- Software Included (PC Only)
- Will fit on any Short-Path System (24/40 Standard)
- USB 3.0 Power Supply
- Visual Plot of Sensory Data Log
- Absorbance & Transmittance Data
- General Pre ID'd Product Concentration
- Set Personal Alerts for Worry Free Operation
- Collect Accurate Fractions
- Improved Run-Times
- ****Great Short-Path Training Tool**
- ****Great for Beginners and Experienced Users Alike**





Consulting Services

At Illuminated Extractors we pride ourselves in being full service extraction specialists. No matter what goals you have for your business we can help make your dreams a reality. We offer on-site consultation services to assist in training for all of our equipment as well as any advanced post-processing techniques. Let us come to your facility and work with your material to create a valuable product the entire time that we are there.

Our team of knowledgeable extraction technicians can help you create every known product in the cannabis and hemp sectors. We are constantly working in our own labs to ensure that we are always current in the most advanced extraction and post-processing methods. We train following all Class 1 Division 1 guidelines to ensure that anyone working with solvents is fully aware of the proper way to handle them ensuring safety at all times.

OUR CORE PROFICIENCIES INCLUDE:

- Liquid Hydrocarbon Extraction
- De-waxing & Winterization Methods
- Gas Distillation, Purification and Purge
- Short-Path Distillation
- CBD/THC Water Solubility
- Isolate Production
- Terpene Distillation
- Cryogenic Systems
- Spinning Band Fractional Distillation
- THC / CBD Separation
- Absolute "Rock" Shatter™
- Ethanol Extractions
- CID1 Safety Training
- SOP's and GMP's
- Facility Design and Build-Out
- Compliancy



MIP Design & Build-Out

Example 1.1 Turnkey MIP Design (Essential 4k Professional 20' Model):

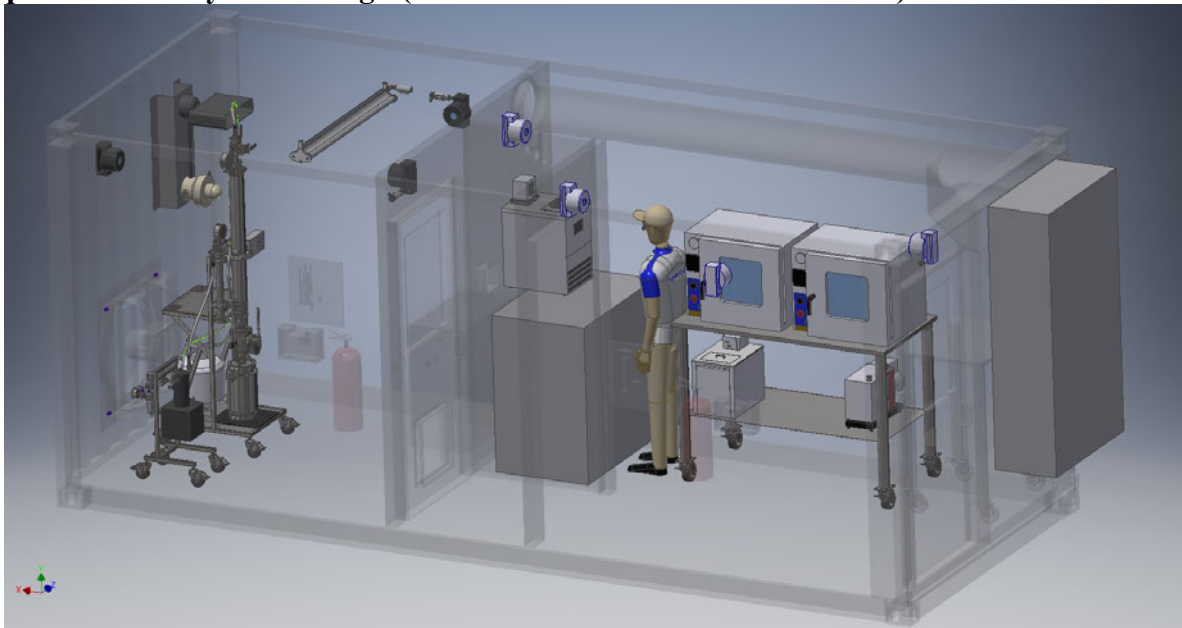

Mobile MIP (E-4k 20' Model)

**This item was designed to be a turnkey solution containing all necessary equipment to conduct butane and propane extractions in full compliance with state and local laws.

**All models are built to order and require a 50% deposit to secure production.

Included in this unit:

- Class 1 Division 1 Electrical
- Gas Detection System w/ Alarm
- Exhaust System w/ Explosion Proof Fan
- Explosion Proof Lighting
- C1D1 (4) and Standard (3) Security Cameras
- 1.9 cu. ft. Vacuum Ovens (2)
- Vacuum Pump
- Off-Gassing Station for Spent Material
- 64 CFM Air Compressor
- ABC Fire Extinguishers (2)
- Stainless Steel Table (60" x 30" x 36")
- Rolling Stainless Steel Table (24" x 30" x 36")
- Fire Proof Cabinet for Tank Storage
- AC/Heater Combo Unit
- Eye Wash Station & All Necessary Tools

Dimensions: 20'(L) x 8'(W) x 8'(H)

Each Design Is Certified Safe and Compliant by:
Pressure Safety Inspectors, LLC



NATIONAL FIRE PROTECTION ASSOCIATION

The leading information and knowledge resource on fire, electrical and related hazards



Facility Design & Build-Out

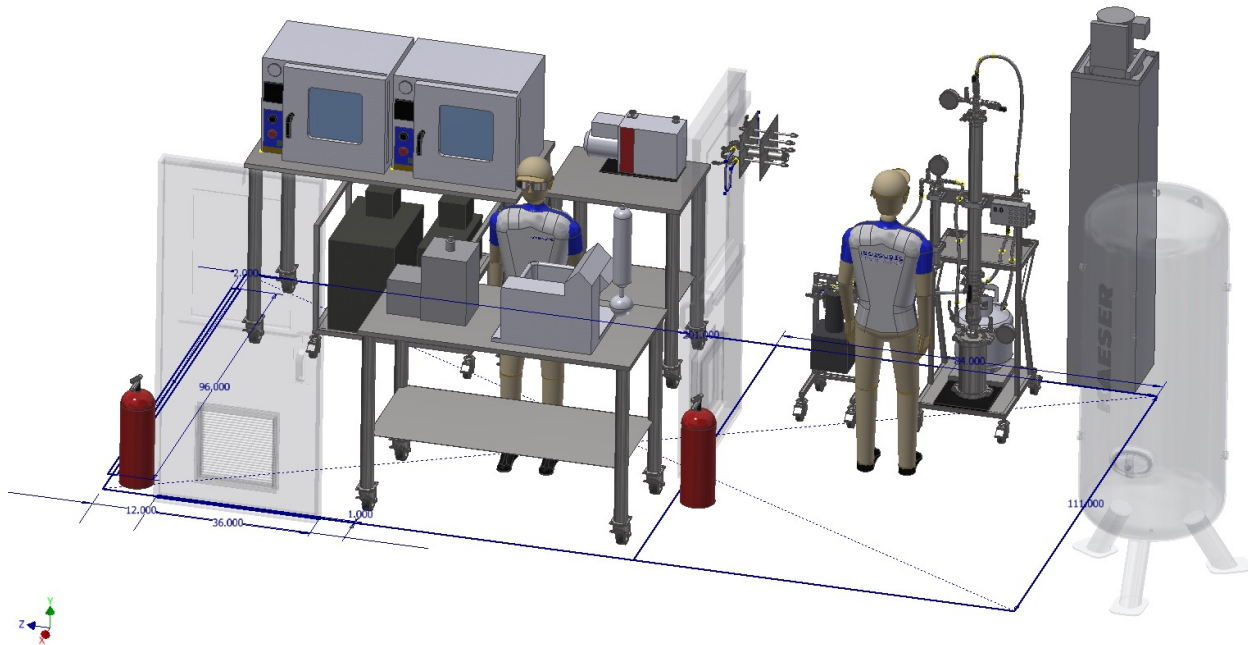

We can help design every aspect of you facility. Give us the dimensions and we will place all equipment in a workable configuration. No matter what the scale we have solutions for your processing lab. We will follow all NFPA, state and local guidelines to make sure your entire facility is compliant from day 1.

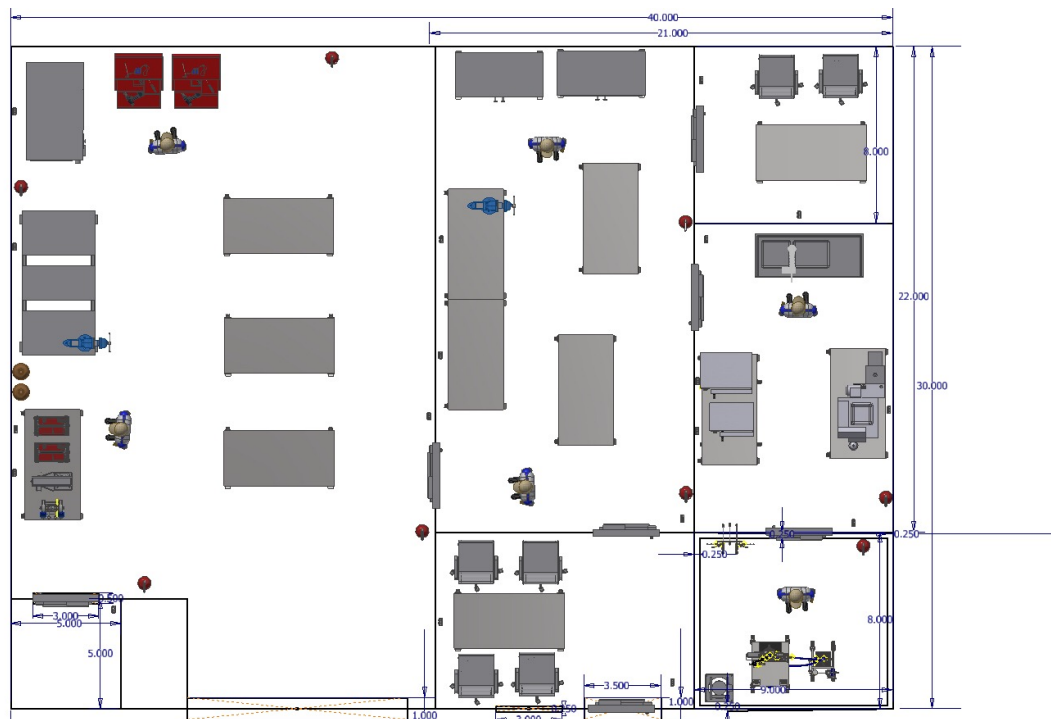

Mobile MIP (Behemoth 40' Model)

Example 3.1 40' Design (The Behemoth Model for Mass Production):

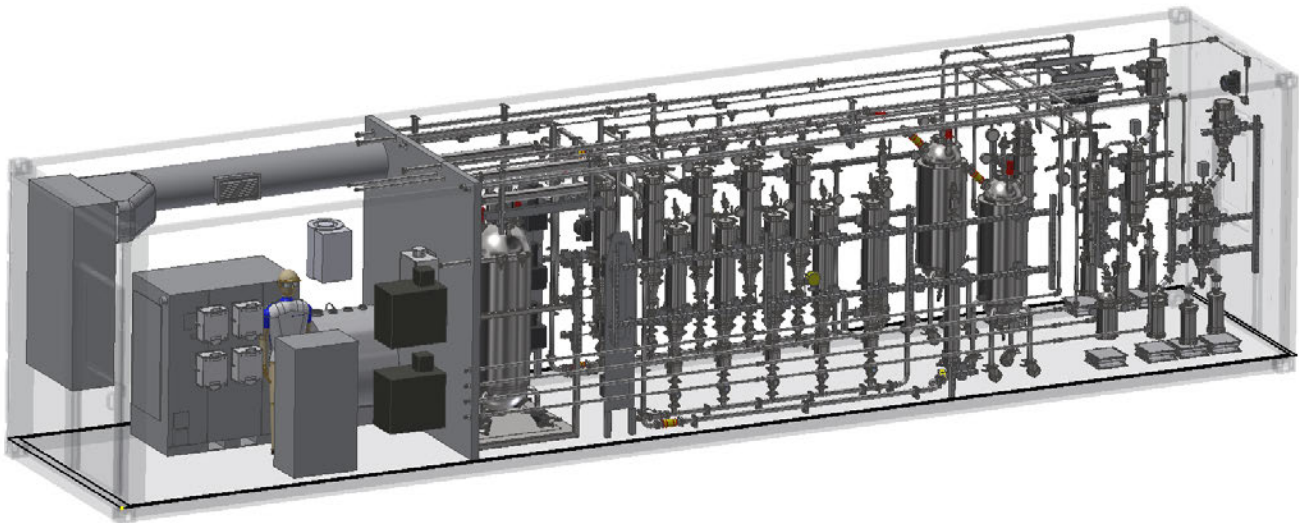

**This Model was designed for large scale commercial use. Designed to process 1000's of pounds of plant material in a 24-hour period.

**This product has only completed the design phase.

Example 3.2 40' Design (The Behemoth Model Side View):

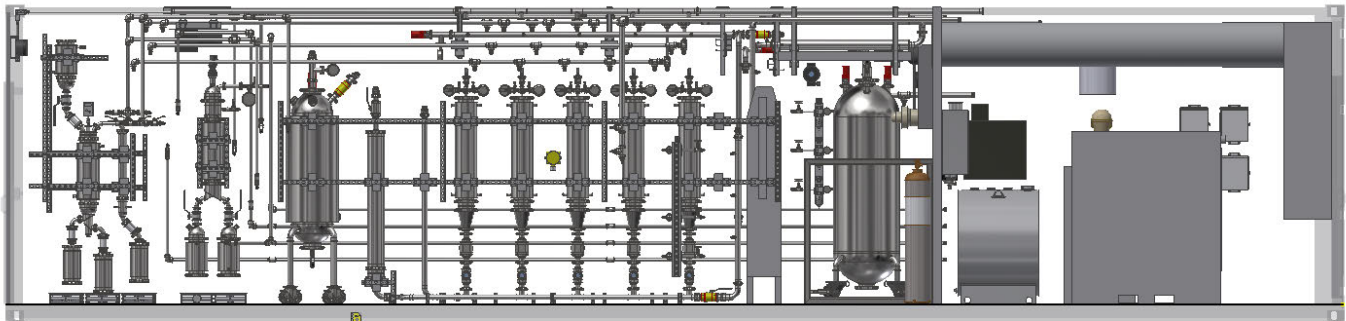

Example 3.3 40' Design (The Behemoth Model Overhead View):

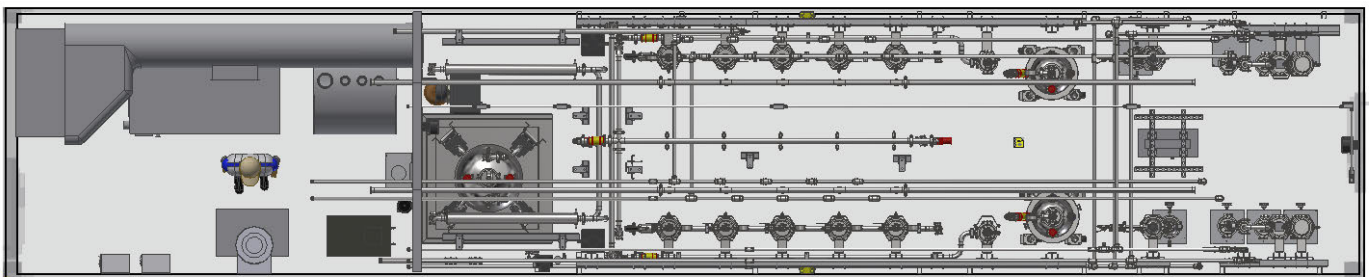

Dimensions: 40'(L) x 8'(W) x 8.5'(H)

Reactors/Crystallizers

Ai R10 2.6 Gallon/10L Glass Reactor



**Fully Customizable
10L Single/Dual
Jacketed Reactor**
\$4,690.00

Insulation jacket extends
chiller life, allows you to
go down to a lower
temperature, and cuts
your utility bill.

**Fully Customizable
20L Single/Dual
Jacketed Reactor**
\$5,900.00



Ai R50 13 Gallon/50L Glass Reactor



**Fully Customizable
50L Single/Dual
Jacketed Reactor**
\$7,990.00



Accessories



Vacuum Ovens (UL Listed)

0.9 Cu. Ft: \$1,890.00

1.9 Cu. Ft.: \$2,790.00

3.2 Cu. Ft.: \$6,090.00

7.5 Cu. Ft.: \$7,960.00

16 Cu. Ft.: \$17,590



Vacuum Pumps

6.9 CFM: \$2,700.00

21 CFM: \$5,200.00



Rotary Evaporator w/ Pump and Chiller

20-Liter Price: \$19,805.00



Complete Turn-key Short Path Distillation System

(Model# 115-YYYYMM###)

5-Liter Price: \$9,800.00

10-Liter Price: \$13,300.00

Butane/Propane

***All Prices Include Tank Deposit*

**24-lb N-Butane
99.99%
\$1,100.00**



**24-lb N-Butane &
70/30 Butane/
Propane 99.8%
\$370.00**



**100-lb Propane
99.8%
\$999.00**



**120-lb N-Butane
99.8%
\$1,200.00**



**114-lb N-Butane/
Propane Blend
99.8%
\$1,400.00**



***Please contact us for more blends and options*



**ILLUMINATED EXTRACTORS
LEADERS IN BOTANICAL EXTRACTIONS**

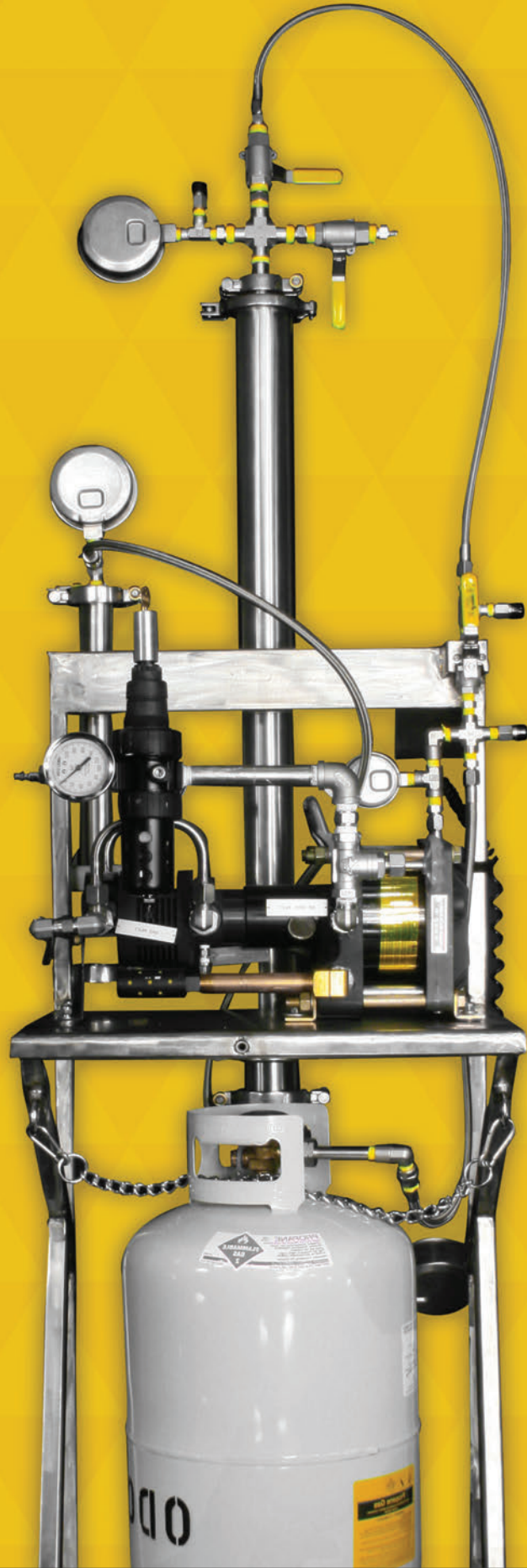

CONTACT US

ILLUMINATED EXTRACTORS
1151 EAGLE DR. #150
LOVELAND, CO 80537

Sales Department

Sales@IlluminatedExtractors.com

**PROFESSIONAL.
CERTIFIED.
SAFE.**

WWW.ILLUMINATEDEXTRACTORS.COM