

600E Series Drop-In Evaluation Board Controller Plus Switch for Fast Prototyping



PRODUCT FLYER
July 2017

General Description

The 600E Series Eval Boards are general purpose and complete solutions to operate most GaN devices. The on-board Controller and Switch provide bias adjustment, power sequence, and protection. Demonstrating device performance is as easy as dropping them in on GaN eval boards, sub-assemblies, and test apparatus. The tiny modules can be mounted on either metal surfaces or on printed circuit boards. Identical connections at opposite sides of the module simplifies placement for fast-prototyping. Drop it, set it, and forget it.

Features

Controller:

- Choice of 100L or 200L. Single power supply. Independent or Sequential Drain and Gate Switching.
- Default TTL control signal is Active-Low. Active-High control is available upon request.
- On-board potentiometer for fine gate bias adjustment.

Switch:

- Rated for 100V, Ultra-low Rds ON, Operation up to 150°C, with derated voltage and current.
- Utilize units at less than half the peak current for best results.

Specification Snapshot

Parameter	Min	Max
Supply (+) Voltage	+20 V	+65 V
Supply (-) Voltage, Optional	-6 V	0 V
Internal (-) Supply V, Gate Pinchoff	-4.3 V	
Internal (-) Supply I	-30 mA	
Gate Bias Voltage Range	-4.3V	-0.5 V
Gate Threshold Shutdown Range	-3.0 V	-0.5 V
TTL Voltage Logic High	+3.6 V	+5.0 V
TTL Voltage Logic Low	0 V	+1.4 V
Avg Current from MOS peak rating		50%
MOS Rds ON (36A to 12A)	0.07 Ω	0.22 Ω
Drain ON Prop Delay, loaded		300 ns
Drain ON Rise Time, loaded		200 ns
Drain OFF Prop Delay, loaded		5 us
Drain OFF Fall Time, loaded		4 us
Soldering Temp (10 sec)		+260°C
Operating Temperature	-40°C	+85°C
Storage Temperature	-65°C	+150°C

Eval Board Configurations

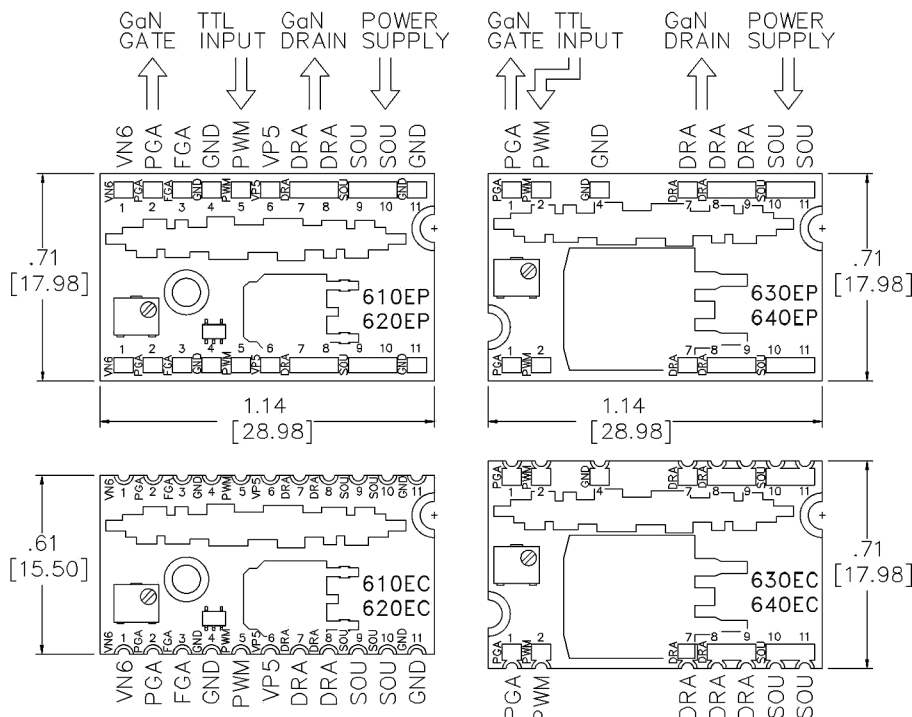

TYPE-EP typically mounts on metal surfaces, while TYPE-EC on printed circuit boards.



Propagation Delay is measured from 90% of TTL to 10% of Drain Voltage with device load. Rise/Fall Times are measured at 10% and 90% of signal. Both measurements are summed for total time.

Ordering Information

Content Type	Mount Type	Shut-down Preset	TTL Enable	Misc Type
610	EP	2R6	AL	20
620	EC	2R0	AH	50
630		1R4		PW
640		OR8		

Example: 610EP2R6AL20

610_100L Controller & 6A Avg (12A Peak) Switch
620_200L Controller & 6A Avg (12A Peak) Switch
630_100L Controller & 16A Avg (36A Peak) Switch
640_200L Controller & 16A Avg (36A Peak) Switch
EP_Mounts on Metal. Pads on top, Ground at bottom
EC_Mounts on PCB. Castellated ports for solder reflow
2R6...OR8_Gate Threshold Shutdown Presets at -2.6V, -2.0V, -1.4V, -0.8V. Has provisions for fine adjustment using one resistor. Refer to XAN-2 application note
AL_Active-Low (0V) TTL. Default for all Controllers
AH_Active-High (<5V) TTL for Gate/Drain Voltage ON
20_Supply range of +20V to +36V. General purpose
50_Supply range of +36V to +65V. General purpose
PW_Operates at PW < 500usec, Duty < 20%. Supply: +20V to +65V

I/O Pin Descriptions

610 PIN	630 PIN	640 PIN	LABEL	DESCRIPTION
1			VN6	Optional Neg Voltage Input (-6V min) for Gate Current Boost. Leave Open.
2	1		PGA	Neg Pulsed Voltage Output to Transistor Gate
3			FGA	Neg Fixed Voltage Output to Transistor Gate
4	4		GND	Ground
5	2		PWM	TTL/PWM Signal Input to Switch Transistor.
6			VP5	Optional Positive Voltage Input (+5V max). Leave Open.
7,8	7,8,9		DRA	High Voltage Output to Transistor Drain. Avoid excess wires or lines to minimize inductive parasitic. Max capacitive load is 500pF for optimum switching speed
9,10	10,11		SOU	High Voltage Power Supply Input. Connect high value storage capacitors here.
11			GND	Ground

Typical Timing Diagrams

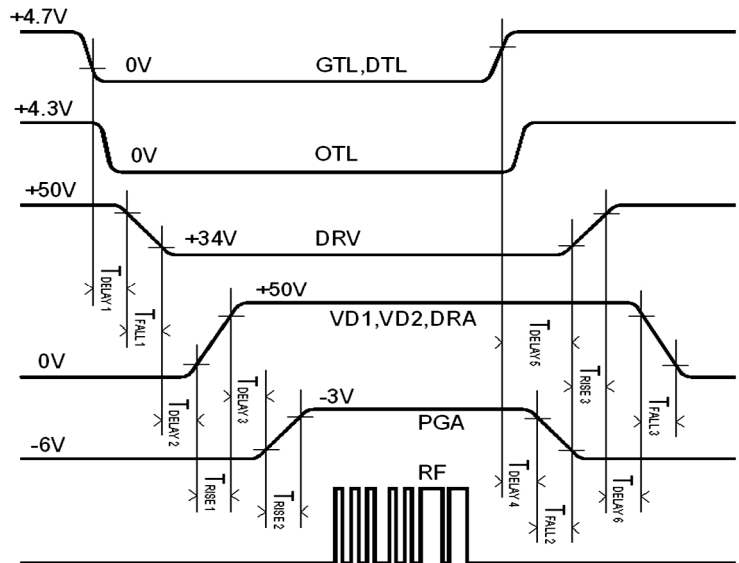

• Refer to Application Note XAN-2 for further details.

Outline & Land Pattern

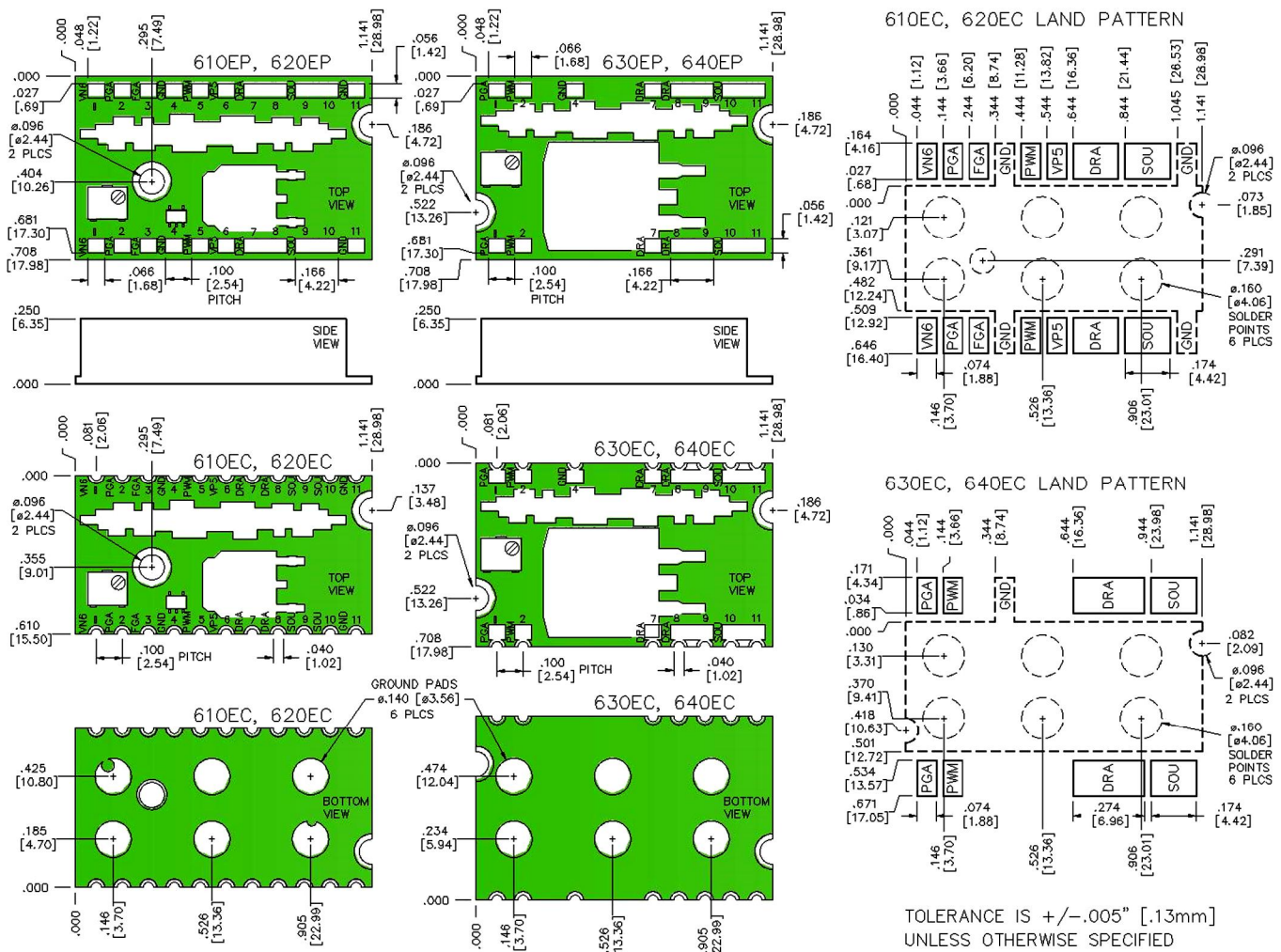

Model Number Color Code

0	1	2	3	4	5	6	7	8	9