

Data sheet

---

## Siemens MAG 8000 with READY Gateway

- Wireless M-Bus
- Long range
- 'Drive-by' or network
- Great measuring accuracy



## Description

---

### Built-in Wireless M-Bus

The meter is delivered with wireless radio communication – Wireless M-Bus – for data communication on 868 MHz which means that consumption data can be easily read remotely. In addition, the data can be read directly from the display or using an optical eye.

### Long range

The meter is equipped with a powerful long-range antenna which sends out a powerful radio signal with intelligent coding to the network. Furthermore, the meter can be read from a long distance via 'drive-by'. In addition, it is possible to mount an external pit antenna to optimise the range.

### 'Drive-by' or network

In the Kamstrup version, MAG 8000 is equipped with the newest radio technology which meets the increasing demands of the market for smart consumption measurement both in case of 'drive-by' and network installation.

### Great measuring accuracy

Magnetic inductive flow measurement guarantees high measuring accuracy. Thus, the meter includes no moving parts, which makes the meter resistant to wear and impurities in the water.

The meter is watertight, IP68 type tested and, therefore, also suitable for installation in meter pits. The meter has been MID approved and type tested according to OIML R49.



\*It is also possible to select a version with power supply for 115 - 230 VAC.

## Meter sizes

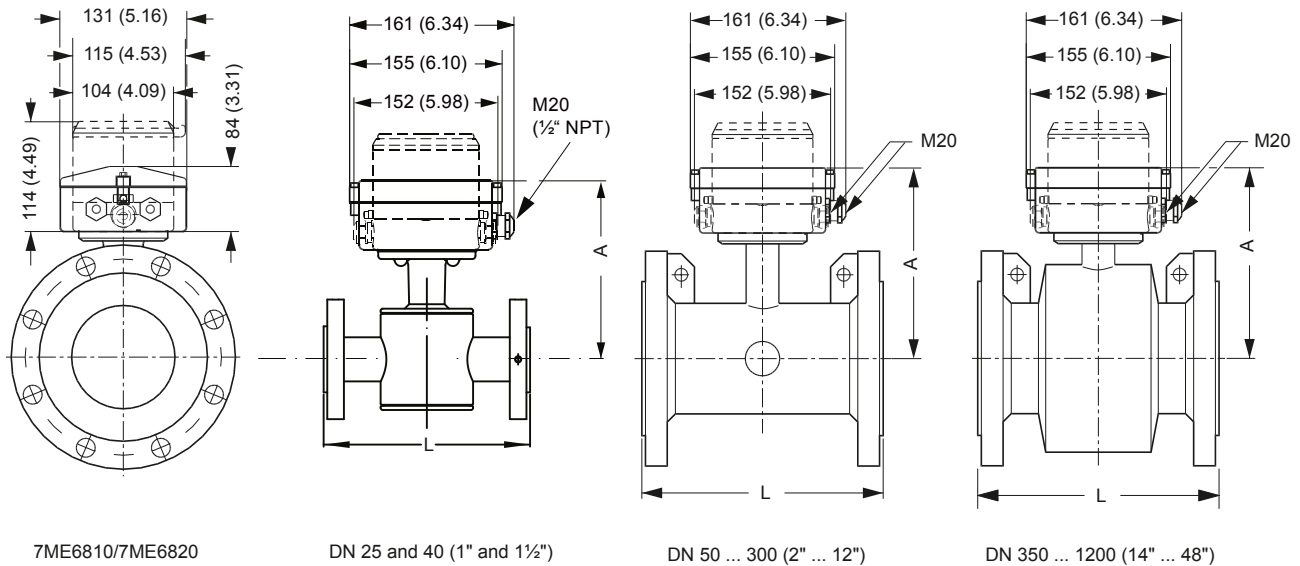

Nominal Size DN	A	L, lengths							D, diameter		Weight 1)	
		EN 1092-1			ANSI 16.5 Cl. 150	AS 4087 PN16	AWWA		DI	D	AS 4087 PN16	
		PN10	PN16	PN40			mm	inch			kg	lbs
50 [2]	195 [7.7]	-	200	-	7.9	200	N/A	N/A	42 [1.65]	2]	11	25
65 [2½]	201 [8]	-	200	-	7.9	200	N/A	N/A	55 [2.17]	2]	13	29
80 [3]	207 [8.2]	-	200	-	7.9	200	N/A	N/A	67 [2.64]	2]	15	34
100 [4]	214 [8.5]	-	250	-	9.8	250	N/A	N/A	81 [3.19]	2]	17	38
125 [5]	224 [8.9]	-	250	-	9.8	250	N/A	N/A	101 [3.98]	2]	22	50
150 [6]	239 [9.5]	-	300	-	11.8	300	N/A	N/A	131 [5.16]	2]	28	63
200 [8]	264 [10.5]	350	350	-	13.8	350	N/A	N/A	169 [6.65]	2]	50	113
250 [10]	291 [11.5]	450	450	-	17.7	450	N/A	N/A	212 [8.35]	2]	71	160
300 [12]	317 [12.6]	500	500	-	19.7	500	N/A	N/A	265 [10.43]	2]	88	198
350 [14]	369 [14.6]	550	550	-	21.7	550	N/A	N/A	350 [13.78]	2]	127	279
400 [16]	394 [15.6]	600	600	-	23.6	600	N/A	N/A	400 [15.75]	2]	145	318
450 [18]	425 [16.8]	600	600	-	23.6	600	N/A	N/A	450 [17.72]	2]	175	394
500 [20]	450 [17.8]	600	600	-	26.8	600	N/A	N/A	500 [19.68]	2]	225	494
600 [24]	501 [19.8]	600	600	-	32.3	600	N/A	N/A	600 [23.62]	2]	340	747
700 [28]	544 [21.4]	700	875	-	N/A	N/A	N/A	N/A	700 [27.55]	2]	316	694
750 [30]	571 [22.5]	N/A	N/A	-	N/A	N/A	N/A	N/A	750 [29.52]	2]	N/A	N/A
800 [32]	606 [23.9]	800	1000	-	N/A	N/A	N/A	N/A	800 [31.49]	2]	398	1045
900 [36]	653 [25.7]	900	1125	-	N/A	N/A	N/A	N/A	900 [35.42]	2]	476	1045
1000 [40]	704 [27.7]	1000	1250	-	N/A	N/A	N/A	N/A	1000 [39.36]	2]	602	1322
1050 [42]	704 [27.7]	N/A	N/A	-	N/A	N/A	N/A	N/A	1050 [41.33]	2]	N/A	N/A
1100 [44]	755 [29.7]	N/A	N/A	-	N/A	N/A	N/A	N/A	1100 [43.30]	2]	N/A	N/A
1200 [48]	810 [31.9]	1200	1500	-	N/A	N/A	N/A	N/A	1200 [47.23]	2]	887	1996

The meter is available in two versions: MAG 8000 or MAG 8000 CT. CT stands for "Custody Transfer" and refers to the fact that the meter has been approved according to OIML R49/MID.

## Functionality

	MAG 8000	MAG 8000 CT
Where is the meter used?	Pumping and district pit	Billing
Output	2 individual pulse outputs	
Communication	Wireless M-Bus, optical eye both on the meter and on READy Gateway	
Power supply	Meter: External battery package with 6 years' lifetime or 230 V Gateway: Internal battery package with 6 years' lifetime	
Meter flow in both directions	Yes	
Drinking water approval	ACS (France), WRc (UK), DVGW (Germany), NSF (USA) and Belgaqua (Belgium). The "Approved for use with drinking water" mark has been applied for.	

## Accuracy

Calibration type	Application	Accuracy	Water meter type
Standard	General water applications	0.4 %	MAG 8000
Extended	High performance applications	0.2 %	MAG 8000
Bulk water/revenue	Custody transfer applications (CT)	Class 1: 1 % at low flow 3 % Class 2: 2 % at low flow 5 %	MAG 8000 CT

## Data package

Volume	Current volume
Volume Month	Shows the volume of the latest month
Volume Reverse	Shows the amount running backwards in relation to the flow direction
Hour Counter	Hour counter
Info code Transmitter	Info code of the transmitter part
Info code Meter	Info code of the meter part
Serial Number	Shows the meter's serial number
Type (CT / ST)	Shows if the meter is a CT or ST meter. CT means that the meter has been approved according to OIML R49/MID

### Kamstrup A/S

Industrivej 28, Stilling  
DK-8660 Skanderborg  
T: +45 89 93 10 00  
F: +45 89 93 10 01  
info@kamstrup.com  
kamstrup.com

Think forward