

WHEATLEY® Series 822 Check Valves

Designed to safely prevent backflow of liquid or gas in pipeline applications

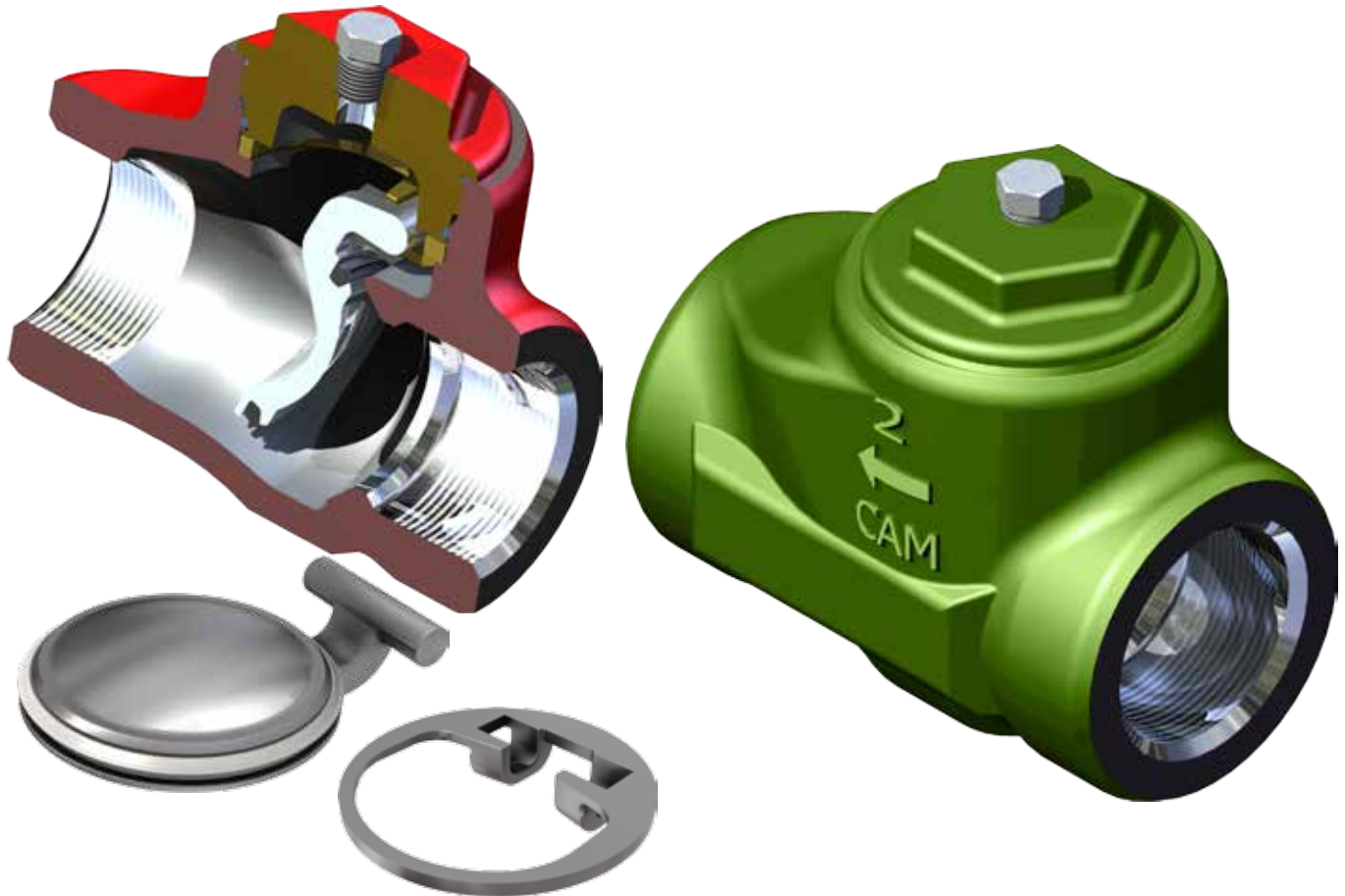

Standard Features

- Designed in accordance with ASME B16.34 (WCC, LCC and CF8M only)
- Materials of construction conform to NACE MR0175/ISO 15156
- Solid 316 stainless steel clapper and hanger reduce the need for separate pins, bushings and rollers
- Compact valve geometry reduces weight and space
- Bevelled, self-aligning clapper and seat design incorporates a molded seal in the clapper for a bubble-tight seal and metal-to-metal secondary seal
- Peroxide-cured Buna-N (FKM and HNBR optional) seals
- Generous wrench area on body and hex-head threaded cover for easier installation and maintenance
- Full opening
- Suitable for horizontal or vertical flow up
- Below-the-threads cover seal isolates the cover threads from line media
- Metal nameplate

WHEATLEY Series 822 Check Valves

Materials List

Item Number	Part Name	Material Series			
		Ductile Iron	Carbon Steel	Aluminum Bronze	Stainless Steel
1	Body	ASTM A395	ASTM A216 Grade WCC or LCC	ASTM B148 Alloy 955	ASTM A351 Grade CF8M
2	Cover	ASTM A216 Grade WCC	ASTM A216 Grade WCC or LCC	ASTM B148 Alloy 955	ASTM A351 Grade CF8M
3	Plug	ASTM A105	ASTM A105/A473-316	ASTM A473 Type 316	ASTM A276 Type 304
4	Clapper/Arm/Pin	ASTM A351 GRADE CF8M			
5	Hanger	ASTM A351 GRADE CF8M			
6	Cover Seal	90-Durometer Peroxide-Cured Buna-N (FKM, HNBR Optional)			
7	Clapper Seal	90-Durometer Peroxide-Cured Buna-N (FKM, HNBR Optional)			

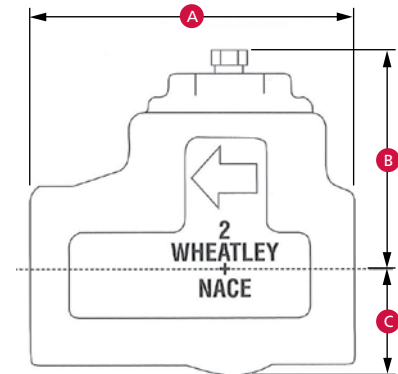
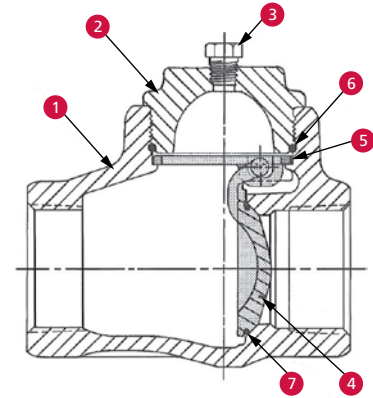

Product Specifications

Material Series	Valve Size in.	End Connection	Working Pressure	Weight lb	A in.	B in.	C in.
Ductile Iron	1	NPT	1000-2000	4	4-1/4	2-3/4	1-1/8
	2	Grooved	2500	9	7	4-1/4	1-13/16
	2	Grooved	2500	10	9	4-1/4	1-13/16
	2	NPT	300-2000	13	6	4-1/4	1-13/16
	2	NPT	300-2000	13	7-1/4	4-1/4	1-13/16
	3	Grooved	2500	22	10-3/4	5-3/4	2-1/2
	3	NPT	600-2000	23	8	5-3/4	2-1/2
Carbon Steel	1/2	NPT	275-3600	4	3-1/2	2-3/4	1-1/8
	3/4	NPT	275-3600	4	3-1/2	2-3/4	1-1/8
	1	NPT	275-3600	4	4-1/4	2-3/4	1-1/8
	1-1/2	NPT	275-3600	10	6	4-1/4	1-13/16
	2	NPT	275-3600	13	7-1/4	4-1/4	1-13/16
	2-1/2	Grooved	275-2160	11	9	4-1/4	1-13/16
Aluminum Bronze	1	NPT	2160-3600	4	4-1/4	2-3/4	1-1/8
	2	NPT	275-3600	13	7-1/4	4-1/4	1-13/16

Model Number Explanation

9D-822 Model	02 Size	3 End Connection	144 Working Pressure	1 Body	31 Trim
820 - Aluminum Bronze	50 1/2" (50 mm)	0 - Socket Weld	027 - 275 WP	1 = Carbon Steel	31 - CF8M SS Clapper/Arm and Hanger, PC Buna Seals 33 - CF8M SS Clapper/Arm and Hanger, FKM Seals 66 - CF8M SS Clapper/Arm and Hanger, HNBR Seals Sour Trim 67 - CF8M SS Clapper/Arm and Hanger, HNBR Seals, Sour Low-Temp. Trim 80 - CF8M SS Clapper/Arm and Hanger, PC Buna Seals, 7-1/4" Length 2": DI Only
822 - Integral Seat	75 3/4" (50 mm)	1 - Grooved	030 - 300 WP	2 = Ductile Iron	
	1 1"	3 - NPT Threaded	060 - 600 WP	3 = Stainless Steel	
	15 1-1/2" (100 mm)		072 - 720 WP	6 = Aluminum Bronze	
	02 2" (150 mm)		100 - 1000 WP		
	25 2-1/2" (200 mm)		150 - 1500 WP		
	3 3" (250 mm)		144 - 1440 WP		
	4 4" (300 mm)		200 - 2000 WP		
			216 - 2160 WP		
			360 - 3600 WP		

EXAMPLE
 9D-822-023144-131 = 2" NPT Threaded-Swing Carbon Steel Check Valve with Stainless Trim and Peroxide-Cured Buna-N Seals

Parts Replacement Kits

Material Series	Order Number	Valve Size in.
Ductile Iron	9D-820-01020*- DIK	1
	9D-820-02020*- DIK	2
	9D-820-03020*- DIK	2-1/2
	9D-820-03020*- DIK	3
	9D-820-04010*- DIK	4
Carbon Steel	9D-820-01036*- CSK	1/2, 3/4, 1
	9D-820-02021*- CSK	1-1/2
	9D-820-02021*- CSK	2
	9D-820-03021*- CSK	2-1/2
	9D-820-03021*- CSK	3
Aluminum Bronze	9D-820-04014*- CSK	4
	9D-820-01036*- ABK	1
	9D-820-02021*- ABK	2

Replace * with a "B" for Buna-N seals, a "V" for FKM seals or "H" for HNBR. Parts kit includes Item numbers 4, 6 and 7.

3250 Briarpark Drive, Suite 300
 Houston, TX 77042
 USA
 Tel 1 281 499 8511