

APPLICATION

The PVS Process Equipment 108-03v Series of vacuum style blower packages takes the guesswork out of sizing your next blower package. With a wide range of quality blowers in configurations for line sizes from 2" to 8", packages can be utilized in a variety of application such as conveying of pellets, powders, or other granular materials. The direct drive design provides operational flexibility capable of accommodating changes on demand. Each blower package includes integrated premium grade silencers with a chambered design for maximum noise reduction. The 108-3v package with horizontal tabletop style base is generally available on units up through 125HP. Larger units may require a skid style base arrangement, please consult the factory for specific details.

DESIGN

The vacuum blower package incorporates an industry-proven positive displacement blower (rotary lobe type). The blower is dynamically balanced, and isolation pads are positioned between the blower and the base to reduce vibration and noise. Depending on the application, vacuum blower motors are available ranging from 3HP to 125HP. An adjustable motor mount accommodates an IEC or NEMA motor bolt pattern. A heavy-duty guard encloses the direct drive coupling to protect facility personnel. The complete motor/blower assembly is supported by a heavy-duty base that allows easy access for service and cleaning. Noise level of the freestanding package without enclosure ranges from 70 to 95 dB depending on the actual configuration and installation of the vacuum blower package. Sound attenuation and weather protective enclosures are available as an option.

OPTIONS

- Sound Attenuation Enclosures
- Variable Frequency Drives
- Rain Caps
- Custom Color Painted Base
- Additional Silencers
- Pipe Couplings and Size Reducers
- Temperature Switch
- Special Voltage Requirement
- NEC Class I, Div. 1, Groups G & D Class II, Div. 2, Groups E, F & G

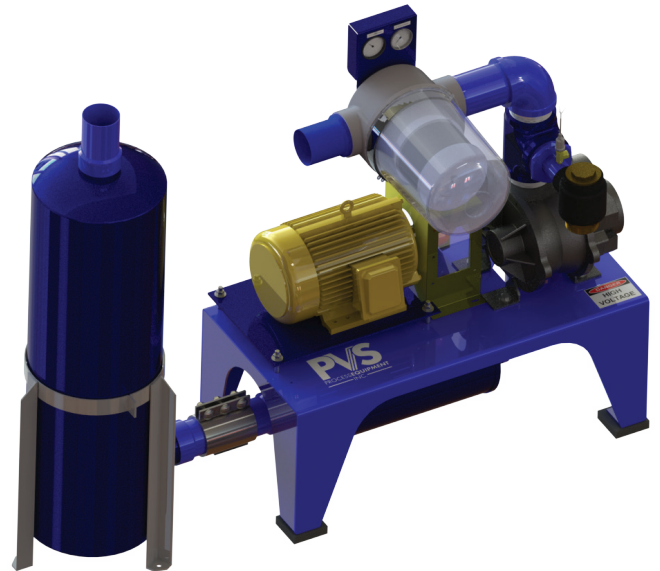

STANDARD SPECIFICATIONS

- Positive Displacement Blower
- Table Top Base (Painted)
- Adjustable Motor Base
- NEMA Premium® Efficiency, Severe Duty, TEFC Motor
- 200-230/380-460 volt, 3-phase, 50/60 cycle motor
- Direct Drive Coupling
- Drive Guard with Inspection Window
- Easy to Read Liquid Filled Gauge
- Vibration Isolation Mounting Pads
- Mechanical Vacuum Relief Valve
- Inter-Connecting Hardware
- Discharge Silencer (Absorptive Type)
- Inlet Filter and Inlet Silencer
- Pressure Gauge
- PVS Textured Blue Painted Base
- For blower performance information such as motor sizes and airflow ranges, contact factory.

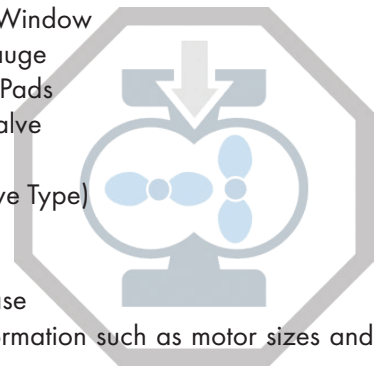

Drawing data is for general reference ONLY. Certified drawings for your application available upon request.

DIMENSIONS OF THE 108-03v SERIES BLOWER PACKAGE

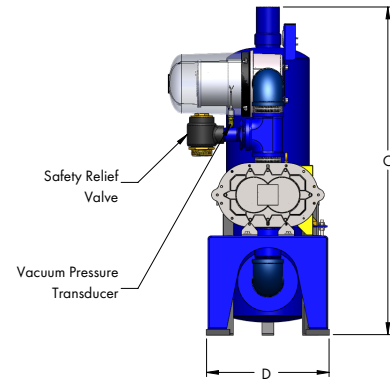
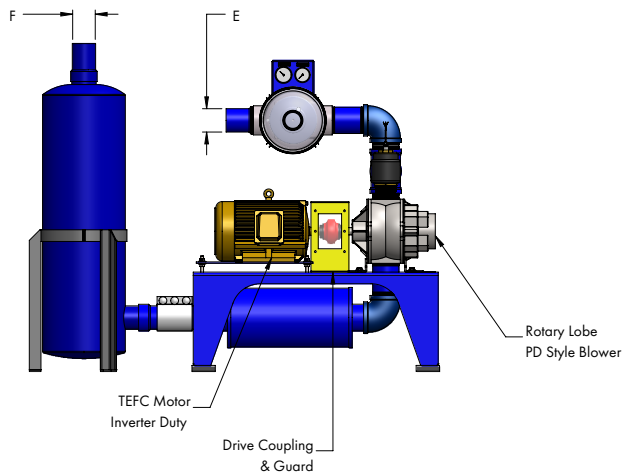
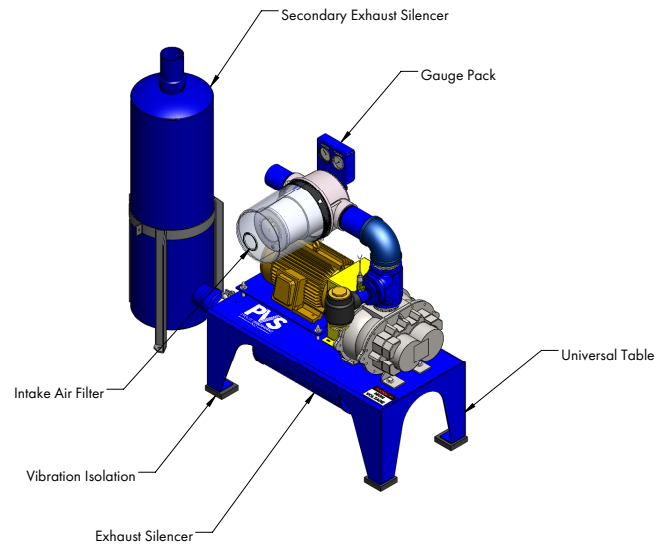
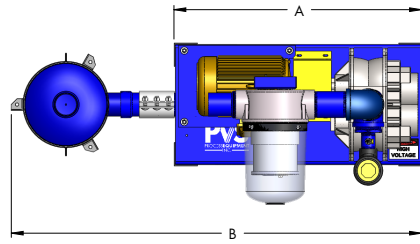

MODEL NUMBER	HP	A	B	C	D	E	F
108-03v-3	3	3'-7"	5'-10"	3'-9"	1'-9"	2½"	3"
108-03v-5	5	3'-7"	5'-10"	3'-9"	1'-9"	2½"	3"
108-03v-7.5	7.5	3'-7"	5'-10"	3'-9"	1'-9"	2½"	3"
108-03v-10	10	3'-7"	5'-10"	4'-6"	1'-9"	3"	4"
108-03v-15	15	3'-7"	5'-10"	4'-8"	1'-9"	3"	4"
108-03v-20	20	4'-4"	6'-4"	5'	2'-1"	4"	4"
108-03v-25	25	4'-4"	6'-4"	5'-2"	2'-1"	4"	5"
108-03v-30	30	4'-4"	6'-4"	5'-8"	2'-1"	6"	6"
All blower volumes are based on standard Inlet Conditions (14.7 PSIA, 70 F)							

CUSTOMER DRIVEN SOLUTIONS.

PVS Process Equipment | 2600 Hamburg Turnpike Suite A | Buffalo, NY 14218
p. 716-646-0181 | f. 716-646-0157

CALL PVS TODAY
855.244.9533