

ANCHORS

SLEEVE ANCHORS

- No hole spotting. No mis-alignments. Simply drill through the fixture into concrete, insert and tighten.
- **Preassembled** for fast, easy installation.
- No special tools necessary; meets federal specifications.
- Ribbed sleeve design assures holding power of expansion sleeve.

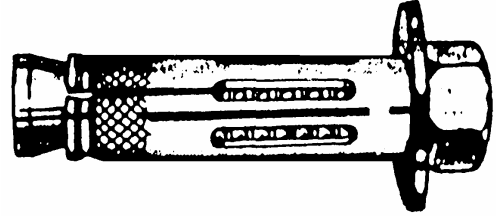

J&B #	DIAMETER & LENGTH	BOLT DIAMETER	MINIMUM EMBEDMENT	QTY
24833	1/4 x 5/8	3/16		100
32325	1/4 x 1-3/8	3/16	1	100
32326	1/4 x 2-1/4	3/16	1	100
24834	5/16 x 1-1/2	1/4	1	100
24835	5/16 x 2-1/2	1/4	1	50
24836	3/8 x 1-7/8	5/16	1-1/4	50
24837	3/8 x 3	5/16	1-1/4	50
24838	1/2 x 3	3/8	1-1/2	25
32324	1/2 x 4	3/8	1-1/2	25
24839	5/8 x 2-1/4	1/2	2	25
38928	5/8 x 3	1/2	2	20
24840	5/8 x 4-1/4	1/2	3-1/2	10
24841	5/8 x 6	1/2	3-1/2	10
24842	3/4 x 2-1/2	5/8	2	10
24846	3/4 x 6-1/4	5/8	3-1/2	5

INSTALLATION:

1. Drill hole to proper size to any depth exceeding minimum embedment. Outside diameter is necessarily larger than actual bolt diameter.
2. Insert assembled anchor into hole, so that washer is flush with material to be fastened.
3. Expand anchor by tightening nut or head 2 to 3 turns.

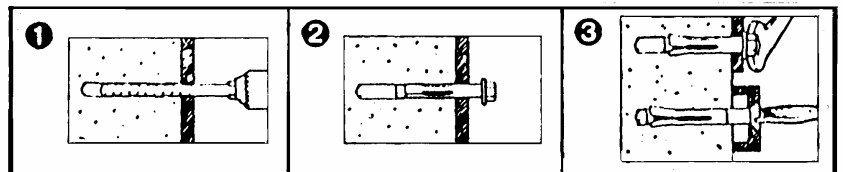

ANCHORS

WEDGE ANCHORS

- Carbon steel. Zinc Plated. Anchor body meets minimum 70,000 psi tensile strength.
- Easy-to-install - up to 50% reduction in fastening time.
- Exceptionally strong - safety step features assures higher and more consistent holding values.
- Special heat-treated spring steel collars dig into concrete and hold better as working load and vibration increases.

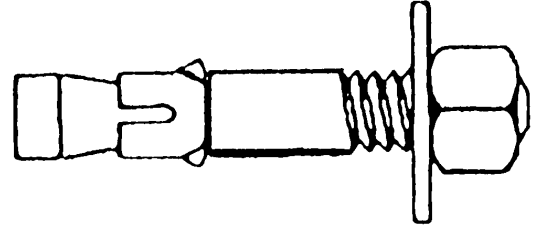

J&B #	DIAMETER & LENGTH	THREAD LENGTH	DRILL BIT DIA	FIXTURE HOLE	WRENCH SIZE	QTY
38650	3/8 x 2-3/4	1-5/8	3/8	7/16	9/16	50
42105	3/8 x 3-3/4	2-5/8	3/8	7/16	9/16	50
38652	1/2 x 2-3/4	1-5/16	1/2	9/16	3/4	25
40205	1/2 x 4-1/4	2-3/16	1/2	9/16	3/4	25
42205	1/2 x 5-1/2	4-1/16	1/2	9/16	3/4	25
40206	1/2 x 7	4-9/16	1/2	9/16	3/4	25
38654	5/8 x 3-1/2	1-7/8	5/8	11/16	15/16	20
40208	5/8 x 6	4-3/8	5/8	11/16	15/16	20
42206	5/8 x 10	6"	5/8	11/16	15/16	10
38656	3/4 x 4-1/4	2-3/8	3/4	7/8	1-1/8	10
42207	3/4 x 5-1/2	3-5/8	3/4	7/8	1-1/8	10
40210	3/4 x 7	5-1/8	3/4	7/8	1-1/8	10
42208	3/4 x 10	6"	3/4	7/8	1-1/8	10
40212	3/4 x 12	6"	3/4	7/8	1-1/8	5

QUICK, EASY INSTALLATION:

1. DRILL HOLE TO DEPTH EQUAL TO LENGTH OF WEDGE ANCHOR.

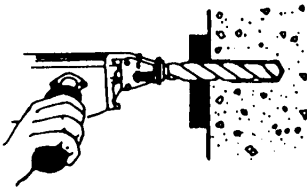

2. INSERT WEDGE ANCHOR SO THAT WASHER RESTS AGAINST FIXTURE.

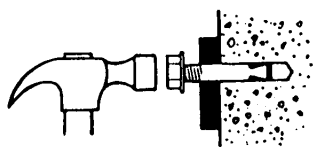

3. TIGHTEN NUT, TWO-TO-THREE FULL TURNS.

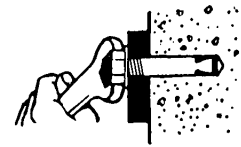

ANCHORS

TITEN HD

Heavy Duty Screw Anchor for Concrete & Masonry Zinc Plated

- Patented, high-strength screw for concrete and masonry.
- The self-undercutting, non-expansion characteristics makes it the ideal anchor for structural applications, even at minimum edge distances & under reduced spacing conditions.
- The proprietary teeth enable it to be installed in one eighth of the time when compared to traditional expansion anchors, and at significantly reduced installation torques.
- This heat-treated anchor undercuts the concrete to create a strong mechanical interlock over the entire length of the anchor.
- Ratchet teeth on the underside of the hex-washer head help prevent the anchor from loosening in vibratory conditions.
- The head is stamped with the anchor length in inches.
- Ideal for temporary anchoring or applications where fixtures may need to be moved.



J&B #	DIAMETER & LENGTH	DRILL BIT	WRENCH SIZE	QTY
4000	3/8 x 4	3/8	9/16	50
4005	1/2 x 4	1/2	3/4	20
4007	1/2 x 6	1/2	3/4	20
4009	5/8 x 4	5/8	15/16	10
4011	5/8 x 6	5/8	15/16	10
4014	3/4 x 4	3/4	1-1/8	10
4016	3/4 x 6	3/4	1-1/8	5

INSTALLATION

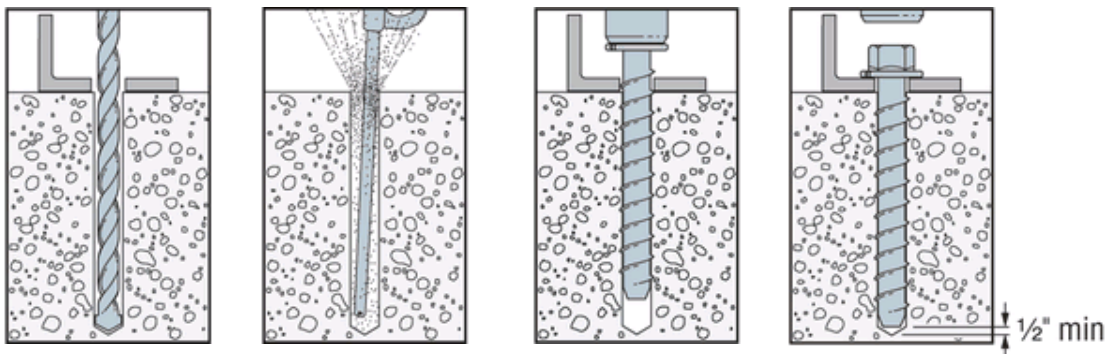

- Drill a hole in the base material using a carbide drill bit the same diameter as the nominal diameter of the anchor to be installed. Drill the hole to the specified embedment depth plus 1/2" minimum to allow the thread tapping dust to settle and blow it clean using compressed air. Overhead installations need not be blown clean. Alternatively, drill the hole deep enough to accommodate embedment depth and dust from drilling and tapping.
- Insert the anchor through the fixture and into the hole.
- Tighten the anchor into the base material until the hex washer head contacts the fixture.
- If the anchor will not install completely, remove the anchor and assure that all dust has been evacuated or drill the hole deeper. Begin re-installation of the anchor by hand to prevent cross-threading.

ANCHORS

SELFDRILL CHUCK END SHIELDS

- A precision-machined combination anchor-drill of high grade steel, specially tempered to insure clean, close-fitting holes and plated to resist rust and corrosion.
- Eight sharp cutting teeth quickly and accurately drill into masonry materials without fouling.
- Selfdrill shields are permanently secured after expansion . . . though fixtures may be readily removed and replaced.

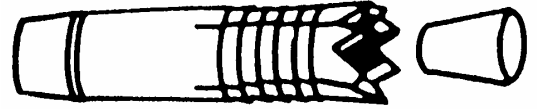

J&B #	BOLT SIZE	OUTSIDE DIAMETER	OVERALL LENGTH	THREAD DEPTH	QTY
24133	1/4	7/16	1-7/32	1/2	50
24138	3/4	1	3-3/16	1	10

* CHUCK END...Installed with power hammer. Snap-off-end type for light-to-heavy-duty installations with standard machine screws or machine bolts.

INSTALLATION INSTRUCTIONS:

1. Place anchor in chuck. Drill hole rotating chuck handle 1/4 turn in each direction.
2. Remove anchors once or twice to remove dust.
3. Remove anchor when chuck face is close to concrete.
4. Clean dust out of hole.
5. Insert plug in anchor and re-insert the entire assembly in the hole, without rotating the chuck, with an electric or air hammer until the chuck is close to the concrete.
6. Break off the tapered end of anchor with a sharp blow on the side of the chuck.
Remove broken off collar from the chuck.

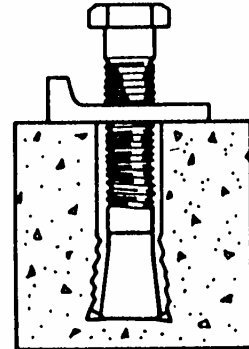

ANCHORS

WOOD SCREW SHIELD

- Made for quick installation of lighter weight fixtures in masonry.
- Made of lead, it will expand without turning in soft material.
- Withstands extreme changes in temperatures and is not affected by moisture or chemicals.



J&B #	SCREW SIZES	HOLE SIZE	ANCHOR LENGTH	QTY
32328	#6-#8	1/4	3/4	100
32329	#6-#8	1/4	1	100
32330	#10-#12-#14	5/16	1	100
32331	#10-#12-#14	5/16	1-1/2	100

TOGGLE WINGS

- Strong spring action opens wings quickly and positively after insertion through wall.
- For use in: hollow walls, tile, plaster, metal, plywood, concrete block.

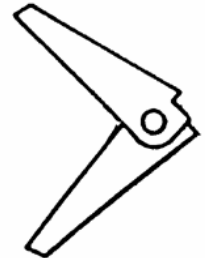

J&B #	THREAD SIZE	HOLE SIZE	WING LENGTH	ULTIMATE TENSION LOAD VALUE	QTY
24110	6-32	3/8	1-3/4	240	100
24111	10-24	1/2	2-1/4	430	100
24112	1/4-20	5/8	2-1/4	900	100
24113	5/16-18	7/8	2-3/4	1030	50
24114	3/8-16	1	3-1/4	1090	50
24115	1/2-13	1-1/4	5	1200	25

EASY INSTALLATION:

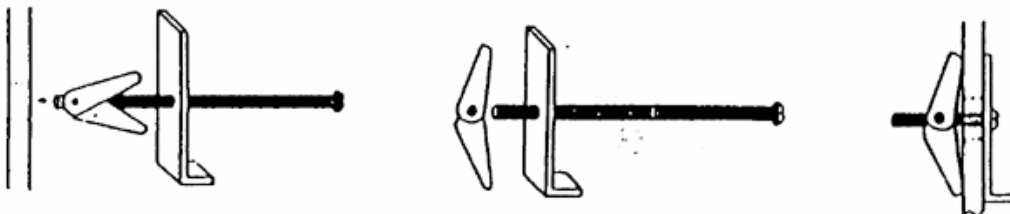

ANCHORS

ALLOY LAG SHIELDS

- A precision die-cast expansion shield of rustproof alloy.
- Heavy external corrugations assure powerful gripping action.
- They cannot be over-tightened, which makes them ideal for use in brittle materials or near the edges of slabs.



INSTALLATION:

SHORT				
J&B #	SIZE	LENGTH	DRILL HOLE	QTY
24128	1/4	1	1/2	50
24129	5/16	1-1/4	1/2	50
24130	3/8	1-3/4	5/8	50
24131	1/2	2	3/4	25
24132	5/8	2	7/8	25

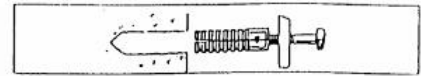

1. Drill recommended hole size. Install shield flush or slightly below surface.



2. Insert lag screw through fixture into shield and tighten.

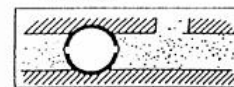

3. In mortar joints, place shield between solid brick so sides bear against brick.

Precision internal shield threads permit easy turning of lag screw without lubrication.



LONG				
J&B #	SIZE	LENGTH	DRILL HOLE	QTY
24123	1/4	1-1/2	1/2	50
24124	5/16	1-3/4	1/2	50
24125	3/8	2-1/2	5/8	50
24126	1/2	3	3/4	25
24127	5/8	3-1/2	7/8	25

MACHINE SCREW ANCHORS

- Designed for shallow-hole applications in all types of solid masonry such as: concrete, stone, brick, mortar, tile and cinder block.
- Economical; fixtures being fastened may be removed and replaced any number of times without loss of holding power in the anchor.

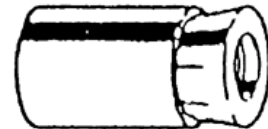

INSTALLATION:

J&B #	BOLT SIZE	DRILL HOLE	MIN HOLE	QTY
24116	6-32	5/16	1/2	100
24117	8-32	5/16	1/2	100
24119	1/4-20	1/2	7/8	100
24120	5/16-18	5/8	1	50
24121	3/8-16	3/4	1-1/4	50
24122	1/2-13	7/8	1-1/2	25

1. Drill hole in masonry. Insert anchor conical end first.



2. Use setting tool to expand lead sleeve into masonry.

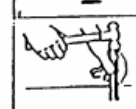

3. Install work by inserting and tightening a standard machine bolt or screw.



ANCHORS

TOGLER PLASTIC ANCHORS

- Ease of installation - can be installed in seconds.
- Greater holding power - up to three times stronger than ordinary wall fasteners.
- Saves money - eliminates the need for long bolts in normal application.

J&B #	SCREW SIZE	HOLE SIZE	QTY
40873	10-24	1/2	25
40874	1/4-20	5/8	25

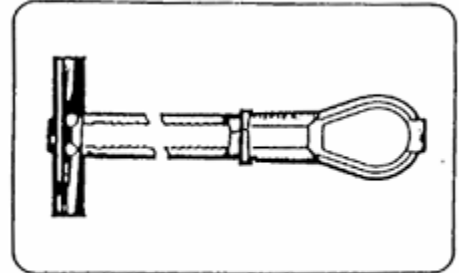

FAST AND EASY TO INSTALL:

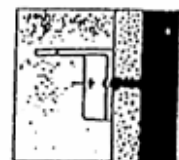
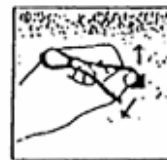
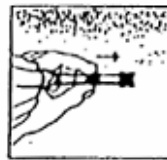
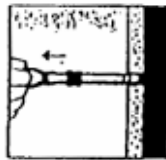
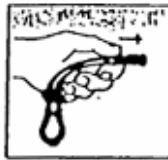
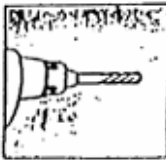

1. Drill proper size hole. (1/2" hole for 3/16" and 1/4" bolt; 3/4" hole for 3/8" and 1/2" bolt).

2. Hold metal channel flat alongside plastic straps and slide channel through pre-drilled hole.

3. With one hand pull ring so metal channel rests flush behind wall.

4. Slide plastic cap along straps with other hand until flange of cap is flush with wall.

5. Place thumb between straps. Push side to side, snapping off straps level with flange of cap.

6. Place item over flange. Insert bolt and tighten until snug against item, then stop.

ANCHORS

PLASTIC ANCHORS

- Inner ridges provide better screw retention to eliminate pull-out.
- Three outer ridges prevent turning or spinning of anchor in the hole.
- Designed to be used with either wood screws or sheet metal screws.



J&B #	LENGTH	SCREW SIZE	DRILL SIZE	QTY
24100	3/4	4-8	3/16	100
24107	7/8	6-10	3/16	100
24108	1	10-12	1/4	100
24109	1-3/8	14-16	5/16	100

INSTALLATION:

1. Drill hole 1/4 inch deeper than length of plastic anchor. Insert plastic anchor flush with surface of wall.
2. Insert screw through fixture into plastic anchor and tighten. Plastic anchor is expanded and will hold firmly.
3. For best results screw should protrude 1/4 inch thru bottom of plastic anchor.
4. Screw length should equal thickness of fixture, plus length of plastic anchor, plus 1/4 inch.

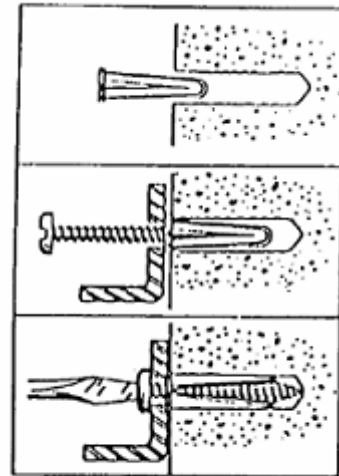

ANCHOR KIT

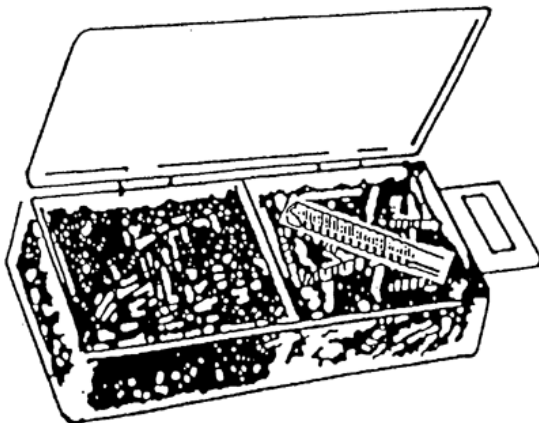

INCLUDES:

- 100 (#10 X 1-1/4) Combo Phil/Slot Pan Head Tapping Screws.
- 100 (10-12) Plastic Anchors.
- 1 ea 1/4 x 4 Carbide Tipped Drill.



J&B #	QTY
40882	EA

ANCHORS

NYLON TAP-IT

Mushroom Type

- Composition nylon construction flexes when subjected to dynamic loads . . . won't shake or vibrate loose.
- Smooth surface prevents snagging of cargo.
- The nylon shell will not fracture fragile materials such as tile or plaster.

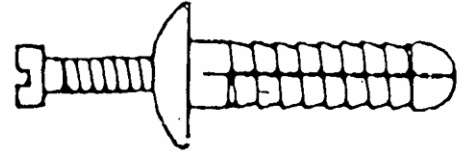

J&B #	DIAMETER & LENGTH	HOLE SIZE	QTY
39270	3/16 x 3/4	3/16	100
39272	3/16 x 1	3/16	100
39274	1/4 x 3/4	1/4	100
39276	1/4 x 1	1/4	100
39277	1/4 x 1-1/2	1/4	100
39278	1/4 x 2	1/4	100

“EXPANDET” VINYL WALL ANCHORS

- Will not turn in hole . . . maintains complete contact.
- Will not fray or flatten out when driven into hole.
- Provides for flush mounting of fixture.
- Not affected by moisture, acids or extreme temperatures.



J&B #	COLOR CODE	SCREW SIZE	LENGTH	DRILL SIZE	QTY
39050	GREEN	10-12	2	1/4	100

INSTALLATION:

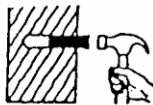

1. TAP ANCHOR INTO HOLE.

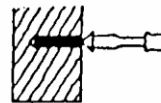

2. INSERT SCREW.

ANCHORS

E-Z ANCOR

Self-Drilling Wallboard Anchor

- Self Drilling . . . one piece anchor. For mounting to gypsum wallboard.
- Fast & Easy . . . no pre-drilling . . . installs easily with #2 Phillips screwdriver . . . no electric drill or other tools necessary.
- Breakaway Point....point can be broken off if cavity behind wallboard is too shallow.
- Secure . . . deep threads provide strong engagement in 3/8", 1/2" and 5/8" wallboard.
- E-Z Anchor Wall Applications: mirrors, shelving and supports, picture frames, brackets, bulletin boards, signs.

EASY ANCOR IS EASY AND FAST TO INSTALL:

1. Place #2 Phillips screwdriver into recess of E-Z Ancor.
2. Press into wallboard, while turning the anchor clockwise until it is seated flush with the wall.
3. Place fixture in position over installed E-Z Ancor. Insert screw with #2 Phillips screwdriver. (#8 screw, type A or AB recommended).
4. Tighten threads of screw securely into the anchor. Do not over tighten.

(A minimum of 1" thread engagement is recommended).

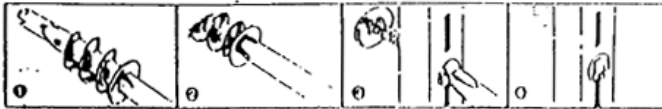

J&B #	DESCRIPTION	QTY
38770	ZINC PLATED	50
42152	NYLON	50

CONCRETE SCREW ANCHORS

Phillips Flat Head



J&B #	SIZE	QTY
4080	3/16 x 1-1/4	100
4081	3/16 x 1-3/4	100
4085	1/4 x 1-1/4	100
4086	1/4 x 1-3/4	100
4088	1/4 x 2-3/4	100

- Creates a mechanical linking of anchor and concrete providing exceptional pullout strength.
- The anchor cuts threads in everything from concrete to brick to cinder block.
- It requires a standard drill or a hammer drill for harder aggregates.

NOTE: Full box of screws includes one carbide tipped drill.

ANCHORS

CONCRETE SCREW ANCHORS

Hex Washer Head



J&B #	SIZE	QTY
40540	3/16 x 1-1/4	100
40541	3/16 x 1-3/4	100
40544	3/16 x 2-3/4	100
40546	1/4 x 1-1/4	75
40547	1/4 x 1-3/4	100
40549	1/4 x 2-3/4	100

NOTE: Full box of screws includes one carbide tipped drill.

- Creates a mechanical linking of anchor and concrete providing exceptional pullout strength.
- The anchor cuts threads in everything from concrete to brick to cinder block.
- It requires a standard drill or a hammer drill for harder aggregates.
- 3/16 sizes use a 5/32 carbide masonry drill bit.
1/4 sizes use a 3/16 carbide masonry drill bit.

CONCRETE DRILL BITS

J&B #	SIZE	QTY
40555	5/32 x 3-1/2	EA
40557	1/4 x 3-1/2	EA



INSTALLATION TOOL SET

J&B #	QTY
40560	EA

INCLUDES 1 EACH OF:

- 1/4" Magnetic Hex Driver for Hex Head Screws
- 5/16" Magnetic Hex Driver for Hex Head Screws
- Magnetic Driver for #2 and #3 Phillips Bits
- #2 Phillips Bit for 3/16" Screws
- #3 Phillips Bit for 1/4" Screws
- Masonry Drill Holder
- Sleeve Assembly
- Allen Hex Key





J&B Fleet - Industrial Supply

22428 Harrisburg-Westville Rd. Alliance, Ohio 44601 Phone: (330) 821-6342 Fax: (330) 821-0411

www.jbfleet.com

PART # 2075

ANCHORS



39050



3/16 GREEN EXPANDET
VINYL WALL ANCHOR

10

40878



5/8 - 3/4 TOGGLER
HOLLOW WALL ANCHOR

4

24109



14-16 PLASTIC ANCHORS

10

24108



10-12 PLASTIC ANCHORS

15

24107



8-10 PLASTIC ANCHORS

20

24100



6-8 PLASTIC ANCHORS

25

38770



E-Z ANCHORS

5

40873

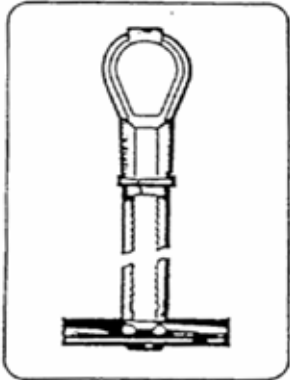

3/16 TOGGLER BOLT

5

40874

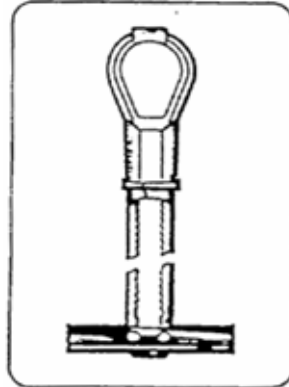

1/4 TOGGLER BOLT

5

40877



3/8 - 1/2 TOGGLER
HOLLOW WALL ANCHOR

6

40876

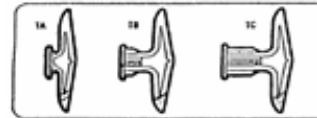

1/8 - 1/4 TOGGLER
HOLLOW WALL ANCHOR

8

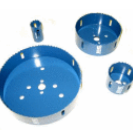

LET US HELP YOU MAKE THE CONNECTION

PART # 3023

ANCHORS



J & B FLEET-INDUSTRIAL SUPPLY
PHONE: 330-821-6342



24100

**4-8 SCREW
3/16 DRILL
PLASTIC**

24107

**6-10 SCREW
3/16 DRILL
PLASTIC**

24108

**10-12 SCREW
1/4 DRILL
PLASTIC**

24109

**14-16 SCREW
5/16 DRILL
PLASTIC**

38770

**E-Z
ANCHORS**



100

100

100

50

25



J&B Fleet - Industrial Supply









22428 Harrisburg-Westville Rd. Alliance, Ohio 44601 Phone: (330) 821-6342 Fax: (330) 821-0411

www.jbfleet.com

PART # 2805

CONCRETE SCREW ANCHORS PHILLIPS FLAT HEAD



<p>4080 1</p>  <p>3/16 X 1-1/4</p> <p>25</p>	<p>4081 2</p>  <p>3/16 X 1-3/4</p> <p>25</p>	<p>4082 3</p>  <p>3/16 X 2-1/4</p> <p>25</p>	<p>DRILLS</p> <p>40555 (3/16)</p> <p>40557 (1/4)</p>   <p>1 EA</p>
<p>4085 4</p>  <p>1/4 X 1-1/4</p> <p>25</p>	<p>4086 5</p>  <p>1/4 X 1-3/4</p> <p>25</p>	<p>4088 6</p>  <p>1/4 X 2-3/4</p> <p>25</p>	



J&B Fleet - Industrial Supply







22428 Harrisburg-Westville Rd. Alliance, Ohio 44601 Phone: (330) 821-6342 Fax: (330) 821-0411

www.jbfleet.com

PART # 2125

CONCRETE SCREW ANCHORS



<p>40541 1</p>  <p>25 3/16 X 1-3/4</p>	<p>40547 2</p>  <p>25 1/4 X 1-3/4</p>	<p>3</p> <p>DRILLS</p> <p>40555 (3/16)</p> <p>40557 (1/4)</p>  	<p>7</p>
<p>40540 4</p>  <p>25 3/16 X 1-1/4</p>	<p>40546 5</p>  <p>25 1/4 X 1-1/4</p>	<p>40549 6</p>  <p>25 1/4 X 2-3/4</p>	<p>1 EA</p>