



Owner's Manual

J7
Monitor

K7
Monitor

LCR7
Array

Snell

SPECIFICATIONS**J7**

| | |
|----------------------------------|--|
| Frequency Response (± 3 dB) | 40 Hz–20 kHz |
| Recommended Amplifier | 100–300 watts |
| Nominal Impedance | 8 ohms |
| Sensitivity (2.83v at 1m) | 88dB SPL |
| Tweeter (video shielded) | 1" (27mm) SEAS silk dome |
| Bass Driver (video shielded) | 6 $\frac{1}{2}$ -inch (165mm) SEAS treated paper cone, 5mm excursion |
| Crossover Point | 2.0 kHz |
| Grille | Perforated metal |
| Dimensions (HxWxD) | 16 x 8 x 13 inches (406 x 203 x 330mm) |
| Shipping Weight | 32 lbs (14.5kg) / each |
| Finish | Black, Cherry, others to special order |

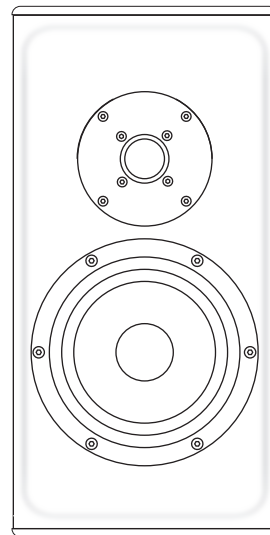
**J7**



K7

LCR7

50 Hz–20 kHz

75 Hz–22 kHz

100–300 watts

50 - 300 watts

8 ohms

4 ohms

87dB SPL

90dB SPL

1" (27mm) SEAS silk dome

1" (27mm) SEAS silk dome

5¹/₄-inch (130mm) SEAS treated paper cone,
5mm excursion

Dual 5¹/₄-inch (132mm) treated
paper cone, 5mm excursion

2.5 kHz

2.0 kHz

Perforated metal

Perforated metal

11⁷/₈ x 7 x 10¹/₂ inches
(302 x 178 x 267mm)

19 x 7 x 8¹¹/₁₆ inches
(483 x 178 x 221mm)

38 lbs (17.3kg) / pair

25 lbs (11.4kg) / each

Black, Cherry,
others to special order

Black, Cherry,
others to special order

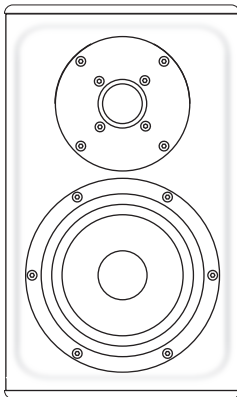

K7

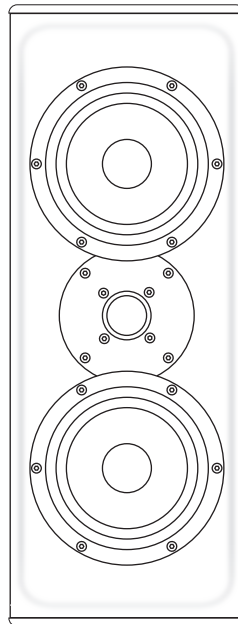

LCR7

PRODUCT DESCRIPTION

The Snell J7, K7 and LCR7 are high performance loudspeakers suitable for use in a wide variety of applications, particularly when space is limited. The J7 and K7 are classic compact Monitors. The LCR7 Array features a D'Appolito MTM design. All the Series 7 models feature compact designs, unique cabinet construction, superior drive units, and complex crossovers, which contribute to their exceptional sound quality.

These Series 7 models are ideal for use as:

- ▶ *The main speakers of a compact music system*
- ▶ *Front, Rear and Center channel speakers of a surround system, especially where space is limited*
- ▶ *Surround speakers in conjunction with larger front speakers*
- ▶ *A multiroom extension speaker*

Snell Series 7 loudspeakers reveal the depth, impact and nuance in every music and movie soundtrack, without the obtrusive look and placement conflicts of typical speakers. Handcrafted in Massachusetts from real wood and solid aluminum, the elegant Series 7 models, with their soft lines and superb finish, plays perfect host to the technology inside.

HOW TO PLACE YOUR SPEAKER SYSTEMS

Speaker Separation

The distance between the speakers determines the width of the stereo image. If the speakers are placed too close together, the image will be too narrow; too far apart and the blend will suffer, creating a hole in the middle.

When properly placed, your speakers will create a continuum of "virtual images" from left to right, with an illusion of sound outside, in front, and behind the speaker systems.

- ▶ *We recommend an angular separation of about 50 degrees (when viewed from above). This is equivalent to a separation between the speaker systems that is about 85% of the distance from the speakers to the listener location.*

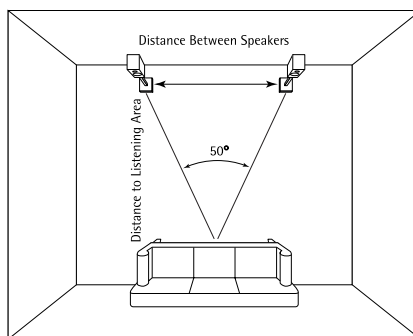

Speaker Distance

Creation of sound between the speakers requires precise placement. The left and right speakers both be the same distance from the listener location. We advise using a tape measure to equalize these two distances to the primary listening position. The results will be well worth the time and effort.



Aiming the Speakers

Your Snell speakers are designed to produce a very smooth response over as wide a range of radiated angles as possible. Like all speakers of this type the response evenness is maintained over a wider horizontal arc than vertical (assuming the long box dimension is vertical). Take this into account when placing and aiming your speakers.

- ▶ *If the speakers are mounted very high or very low, aim the center of the speaker to your ear level while listening in a seated position.*
- ▶ *If this is not possible, it may be preferable to place the speakers on their sides.*

Toe-In

"Toe-in" refers to the angling of the speaker systems toward the listener location. Toe-in is a matter of taste. As the degree of toe-in increases, the stereo effect becomes more direct-sounding, like a pair of headphones. Speakers not toed-in will give a more diffuse sound with a less defined central image.

Location Affects Bass

As speakers are moved closer to rigid room boundaries - the walls, the floor, and the ceiling the deep bass part of the sound range is accentuated. However, if speakers are too close to the room boundaries, particularly corners, the bass output can be uneven. Experiment until you find the best overall sound for your room. Choose a musical selection with a strong, continuous bass line. Repeat a short section until you have a firm impression of it in your mind, then try another speaker location. Repeat this process until you are content with the bass response you are getting. Moving your listening position will affect the sound as much as moving the speakers. Try different listener locations as well as speaker locations.

The Placement Switch

In some situations it may be best to position the speakers in a location that does not produce the best overall sound balance. A common example is in audio/video installations where, in order get the best sound image, the speakers must be placed next to a large cabinet or big screen television. This can cause uneven response in the upper bass and lower midrange which can make voices sound unnatural. The Snell J7, K7 and LCR7 feature a Placement Switch, located in the upper left corner of the terminal cup, that can help restore smooth response in such situations.

If the speaker is located where it has at least 12 inches (30cm) of clearance on three sides, use the Normal switch setting (toggle up). If it is placed next to a large object, try the Boundary switch (toggle down) position to see if it results in smoother response.

When Used as a Center Channel

In a multichannel system the center channel keeps dialogue or soundtrack information centered. Therefore, its placement relative to the left and right speakers is critical.

- ▶ *Place the speaker on top of or beneath your TV, with its front edge as far forward as practical. Try to keep the front of the speaker flush with the front of the screen.*
- ▶ *Try to place all front speakers at approximately the same height. If possible, the center speaker height should be within 2 feet (60cm) of the height of your left and right speakers.*
- ▶ *If you need to place the speaker any higher or lower, angle it toward ear level. If this is not possible, place the speaker on its side for best results.*

CONNECTING THE SPEAKERS

Warning! To prevent electrical shock, always switch off the amplifier or receiver when making connections to the speaker system.

Choosing cable

We recommend 16 gauge cable or thicker for runs up to 25 feet (8m) and 12 gauge wire or thicker for longer runs. (We use a custom-configured 12 gauge oxygen-free cable in our crossover networks.)

Connecting with bare wire:

- ▶ Insert bare wire into holes and tighten.

Connecting with banana plugs, pins or spade lugs:

- ▶ The gold-plated binding posts accept standard banana plugs and pins, and can accommodate spade lugs to 5/16-inch.

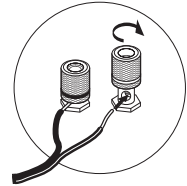

Basic Connections

- ▶ Keep the speaker terminal jumper straps in place
- ▶ When making connections, be sure to connect + to + (red) and - to - (black).

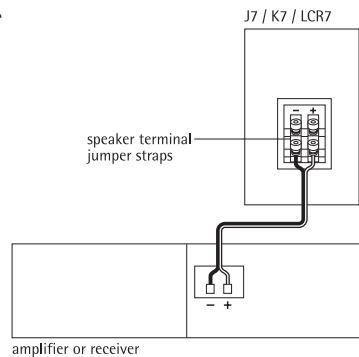

Bi-Wiring

- ▶ Use equal lengths of the same kind of cable when bi-wiring each speaker
- ▶ Unscrew both sets of terminals and remove the jumper straps
- ▶ When making connections, be sure to connect + to + (red) and - to - (black).

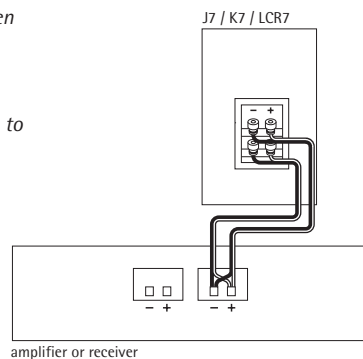

Bi-Amplifying

Using One Amplifier for the Bass and One for the High End

- ▶ Unscrew both sets of terminals and remove the jumper straps
- ▶ Connect the cables from the bottom set of terminals to the amplifier driving the bass unit
- ▶ Connect the cables from the top set of terminals to the amplifier driving the tweeters
- ▶ When making connections, be sure to connect + to + (red) and - to - (black)
- ▶ Do not use an external crossover. It will interact with the phase and frequency response of the speaker.

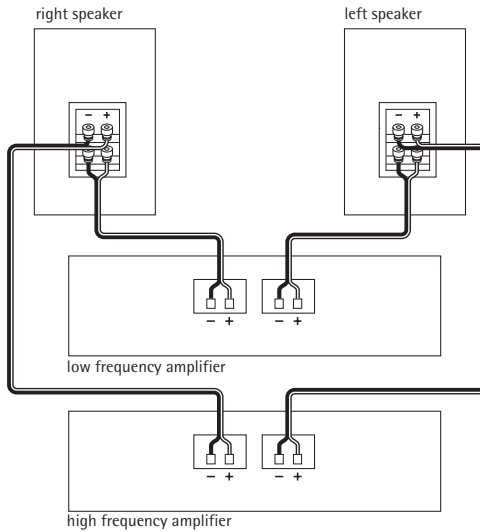

Using One Amplifier for Each Speaker

- ▶ Use two identical amplifiers
- ▶ Unscrew both sets of terminals and remove the jumper straps
- ▶ Connect the cables from the bottom set of terminals to the first amplifier's right channel
- ▶ Connect the cables from the top set of terminals to the first amplifier's left channel
- ▶ Repeat steps 2 and 3 for the second amplifier

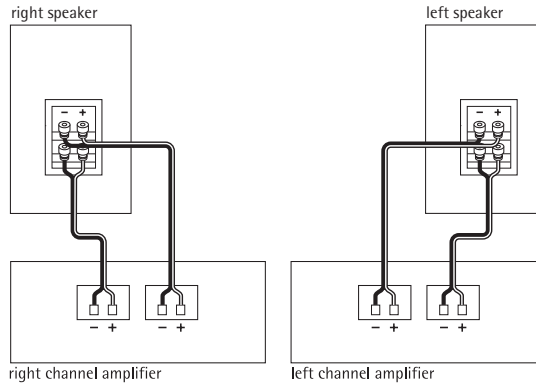

Using With a Multichannel Surround Processor

When using a subwoofer:

- ▶ Select the **SMALL** setting on your receiver or processor for your main and center channels. This routes all bass information (typically below 100Hz) to your subwoofer.

When not using a subwoofer:

- ▶ Select the **LARGE** setting on your receiver or processor for your main speakers. This routes all bass information (typically below 100Hz) to your main speakers. Otherwise, bass information will be lost.

Matching the sound levels of each speaker:

- ▶ Your home theater system most likely includes a test signal that simplifies level matching. Refer to the instructions provided with these electronics.



HOW TO CARE FOR YOUR SPEAKERS

- ▶ *Use a soft terry cloth towel slightly dampened with water, glass cleaner, or a diluted mild detergent. The towel should be just damp enough to wipe the surface clean without leaving a trail of moisture.*
- ▶ *Do not use abrasive cleaners or any cleaner containing chemicals harsher than those found in glass cleaner.*

LISTENING LEVELS AND POWER HANDLING

- ▶ *The power recommendation for the system assumes you will operate the amplifier in a way that will not produce distortion. All speakers can be damaged by even a modest amplifier if it is producing distortion. If you hear a gritty noise or other signs of strain, turn down the volume. Prolonged or repeated operation of your speakers with a distorted signal can cause damage that is not covered by the warranty. It is especially important that you do not overdrive the bass capability of smaller speakers. Watch for noises, such as pops, caused by the music's bass line. Use of the loudness control and/or full bass boost at louder volumes is likely to overdrive the woofer. Use such controls sparingly.*

LIMITED WARRANTY

For five years from the date of purchase, Snell Acoustics will repair for the original owner any defect in materials or workmanship that occurs in normal use of the speaker system, without charge for parts and labor.

Your responsibilities are to use the product according to the instructions supplied, to provide safe and secure transportation to an authorized Snell Acoustics service representative, and to present proof of purchase from an authorized Snell dealer in the form of your sales slip when requesting service.

Excluded from this warranty is damage that results from abuse, misuse, accidents, shipping, repairs, or modifications by anyone other than an authorized Snell Acoustics service representative. This warranty is void if the serial number has been removed or defaced.

If Service Seems Necessary

Contact the dealer from whom you purchased the speaker system.

If that is not possible, call us at 607-352-2488, or write to:

Snell Acoustics
2 Chambers Street
Binghamton, NY 13903

We will promptly advise you of what action to take. If it is necessary to return your speaker system to the factory, please ship it prepaid in the original factory packaging. Please note that Snell Acoustics will not be held liable for shipping damage due to improper packaging. After it has been repaired, we will return it freight prepaid in the U.S. or Canada.

Snell

2 Chambers Street
Binghamton, NY 13903-2699
phone: 607-352-2488
fax: 607-352-2498
email: info@snellacoustics.com
www.snellacoustics.com

©2009 Snell Acoustics. All Rights Reserved.
Specifications are subject to change without notice.
Covered by patents issued and/or pending.
Part #542-1044