



SELF FLASHING CURB

MODELS:
LS-SF (STEEL)
LA-SF (ALUMINUM)



APPLICATION

The LS-SF/LA-SF is Lloyd's self flashing curb. LS-SF consists of a 16 gage galvanized steel, 3lb. Density 1" thick insulation and 2"x2" nominal wood nailer. The steel insulated curb is 8" high with 1" of insulation. LA-SF consists of aluminum alloy 3003-H-14, 3lb. Density 1" thick insulation and 2"x2" nominal wood nailer. The aluminum insulated curb is 8" high with 1" of insulation.

STANDARD CONSTRUCTION

Fabricated using 16 gage galvanized steel
3lb. Density 1" thick insulation
2"x2" nominal wood nailer
Mill finish is standard
"C" dimension=8in.
Damper tray optional

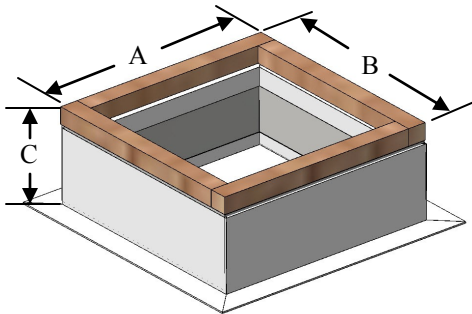

Side	Minimum Size	Maximum Size
A	6"	Contact factory
B	6"	
C	8"	

LS-SF **Steel Self Flashing Curb**

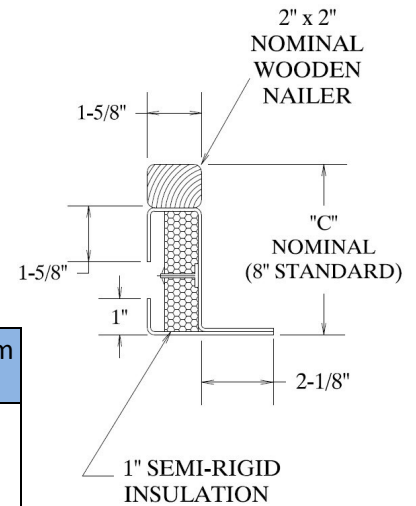

STANDARD CONSTRUCTION

Fabricated using aluminum alloy 3003-H-14
3lb. Density 1" thick insulation
2"x2" nominal wood nailer
Mill finish is standard
"C" dimension=8in.
Damper tray optional

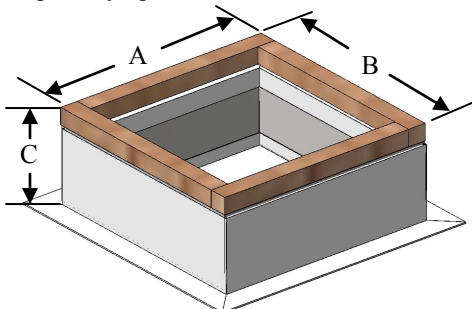

Side	Minimum Size	Maximum Size
A	6"	Contact factory
B	6"	
C	8"	

LA-SF **Aluminum Self Flashing Curb**

