

# OWS-BP MODEL

UNDERGROUND OIL/ WATER  
SEPARATORS - BYPASS TYPE

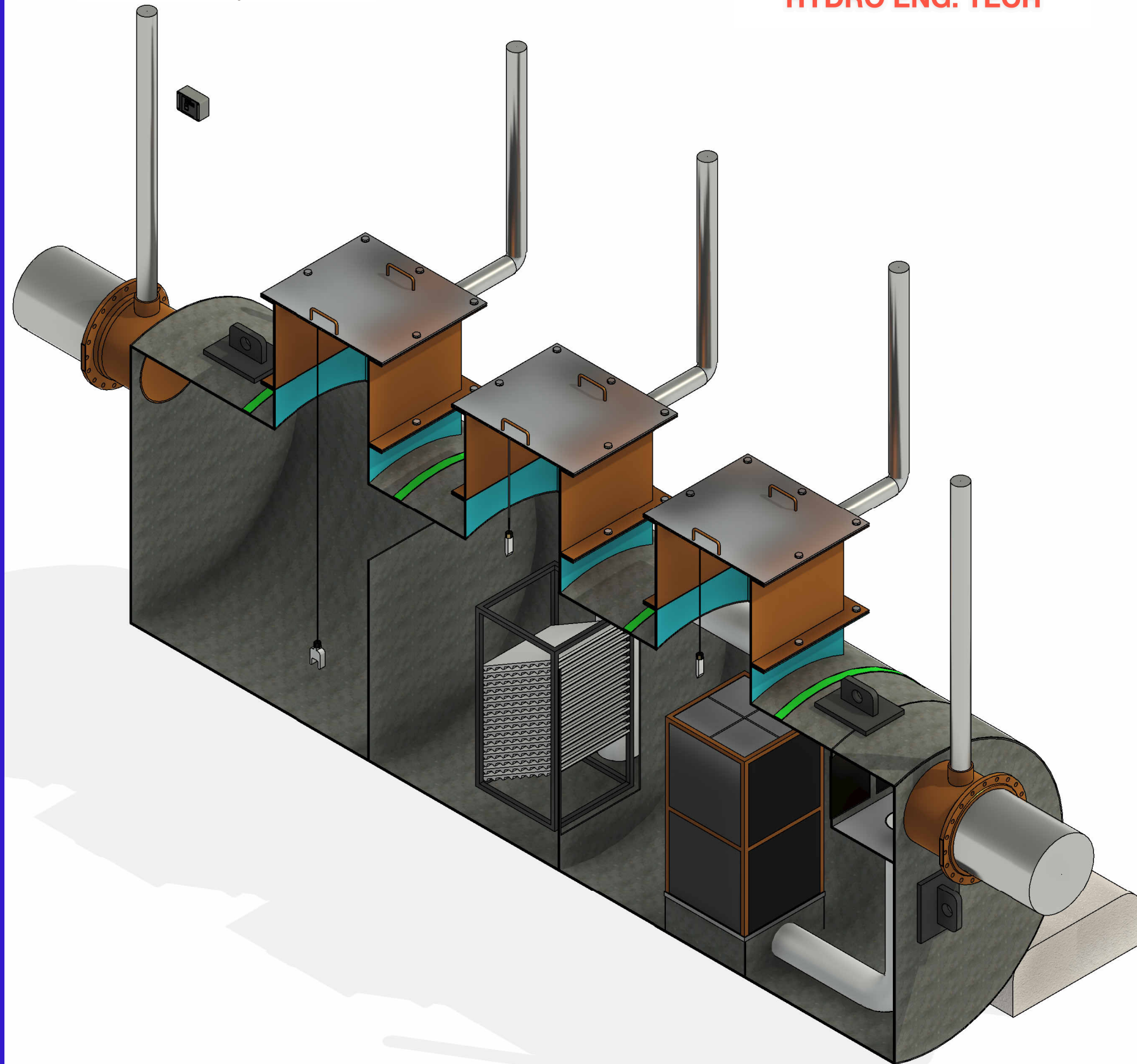

UNITED INTERNATIONAL  
HYDRO ENG. TECH



# OUR EXPERIENCE

UIHT offers customized Oil Separator Tank packages for the reduction of oil and gas in storm and drainage water. UIHT maintains project management and quality assurance standards that are in compliance with the requirements of the leading oil and petrochemical companies across the globe.

UIHT optimized process design and comprehensive project management can produce a cost-effective package.

Our OWS-BP Oil/ Water Separators are the most widely used separators where it is acceptable to treat the 'first flush' ie. flows according to the nominal size (NSB) generated by rainfall rates of up to 6.5mm/hour. This covers most rainfall events in the world. Any excess rainfall is by-passed without treatment. The OWS-BP by-pass separator is a well proven high quality factory made unit, designed and tested in accordance with the European Standard BS EN 858-1 and meets the requirements of the Environment Agency's Pollution Prevention Guidelines PPG3 and the Construction Products Regulations. Our by-pass separators are manufactured in class 1 and class 2 models and with or without silt capacity in accordance with BS EN 858-1.

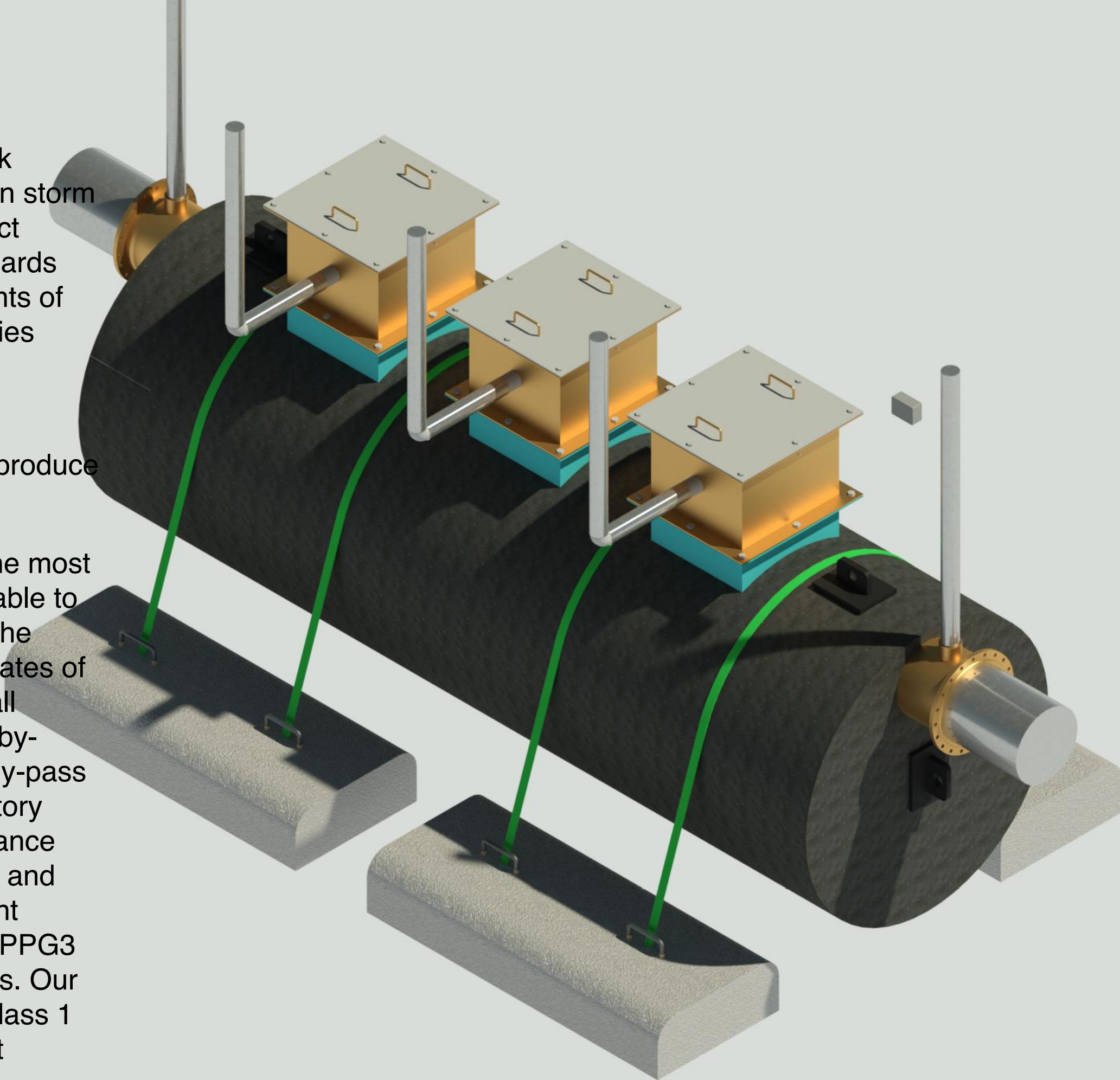

# UIHT Oil/ Water Separators by Coalescence:

OWS-BP Separators are engineered to collect sand, grit, grease and free oil (hydrocarbons and other petroleum products) from storm water runoff, spills and vehicle maintenance operations.

## Function:

The Oil/ Water Separator is a stationary underground, wastewater treatment vessel, filled with water. Internal baffles and inclined plate/ cartridge coalescers to accelerate the oil/ water separation process. Waste accumulates within the separator while effluent is discharged by gravity. The system is designed for access from above for observation, maintenance and cleaning.



## Characteristics:

- Outlet parameters lower than 5 ppm.
- Includes a dedicated sand and solids settling chambers.
- Designed in accordance with EN 858.
- Vessel manufactured in Epoxy Coated Carbon Steel.
- Oil and hydrocarbon separation and solids settling chambers.
- Accumulation of oil and hydrocarbon on water surface.
- Coalescing plates with large specific surface: 240 m<sup>2</sup>/m<sup>3</sup>.
- Polishing coalescing cartridge on final stage.
- Oil removal by upper manhole.
- Level sensors for oil interface layer, high water level, and solids level.

**OWS-BP** Oil/ Water Separators are unparalleled in performance, structural strength, product compatibility, and corrosion resistance. With hundreds of high-performance separators in commercial operation throughout the world, UIHT's patented oil/ water separators have a proven record of reliability.

UIHT engineers have designed a functional means of primary separation that not only meets these federal, state, and local oil and grease discharge limitation requirements, but also surpasses them. And unlike other oil/ water separators, UIHT separators are easy to operate and maintain!

Each Oil/ Water separator is backed by UIHT Tank's professional design, engineering, fabrication, delivery and service. **OWS-BP** separators come directly from UIHT's manufacturing facilities. This practice ensures complete quality control, from expert design to timely delivery by our experienced drivers. Construction and performance certification of the separator in strict accordance with Underwriters' Laboratories Subject SU-2215 is also available.

**OWS-BP** Oil/ Water Separators handle a wide range of oily discharges from paved surfaces at petroleum, industrial, military, commercial, and municipal facilities. Most common applications include facilities with vehicle fueling, repair/ maintenance areas and wash pads. **OWS-BP** Oil/ Water Separators come in a variety of capacities and designs, available in either a cylindrical or rectangular vessel. Single and double-wall construction is available for both underground and aboveground applications.



**OWS-BP** Oil/ Water Separators are competitively priced and are readily available from a network of knowledgeable regional factory representatives and distributors. In addition, UIHT provides a wide array of support information, including an engineering manual with detailed information, specifications, and engineering drawings for selecting and specifying oil/ water separators and accessories. You can depend on UIHT Tank to provide you with environmentally safe

and structurally sound oil water separator solutions well into the 21st century and beyond.

In addition, all protected **OWS-BP** Oil/ Water Separators carry a 30-year limited warranty against corrosion and structural failure.

From the solid heavyweight construction to the patented design and operating simplicity, a **OWS-BP** Oil/ Water Separator is a product of experience, backed by a company with 15+ years of private ownership and management.

## Additional Features:

- Oil and Hydrocarbon Detection Alarm.
- Oil maximum level alarm.
- Maximum Solids level alarm to avoid clogging.
- Mechanical skimmer for separated oil removal.



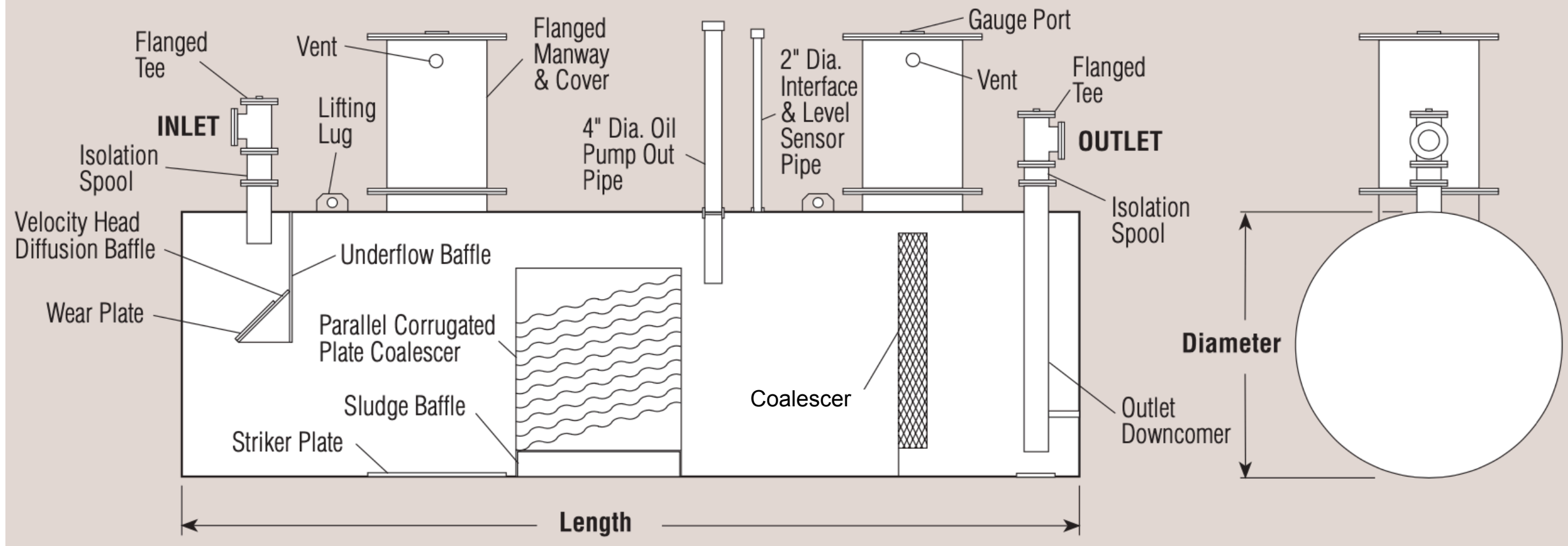

<b>MODEL</b>	<b>Nominal Size (NSB) Flow (l/s)</b>	<b>Nominal Flow (m3/h)</b>	<b>Peak Flow Flow (l/s)</b>	<b>Oil Storage NSBX15 (L)</b>	<b>Silt Storage NSBX100 (L)</b>	<b>Length (mm)</b>	<b>Diameter (mm)</b>	<b>Inlet/ Outlet Pipe (mm)</b>	<b>Approx. Wt. (Kg)</b>
OWS-BP-005	005	018	0,050	75	500	2,000	1,300	200	791
OWS-BP-010	010	036	0,100	150	1,000	3,200	1,300	300	1,103
OWS-BP-015	015	054	0,150	225	1,500	4,300	1,300	350	1,390
OWS-BP-030	030	108	0,300	450	3,000	4,800	1,800	450	2,998
OWS-BP-040	040	144	0,400	600	4,000	6,000	2,000	500	4,057
OWS-BP-050	050	180	0,500	750	5,000	6,800	2,000	600	4,484
OWS-BP-100	100	360	1,000	1,500	10,000	7,500	2,700	850	6,961
OWS-BP-150	150	540	1,500	2,250	15,000	8,000	3,000	1,000	8,327
OWS-BP-200	200	720	2,000	3,000	20,000	8,500	3,600	1,200	10,934
OWS-BP-250	250	900	2,500	3,750	25,000	10,000	3,600	1,300	12,376
OWS-BP-300	300	1,080	3,000	4,500	30,000	10,500	4,200	1,400	15,537
OWS-BP-400	400	1,440	4,000	6,000	40,000	13,800	4,200	1,600	19,236
OWS-BP-500	500	1,800	5,000	7,500	50,000	16,000	4,200	1,800	21,702

# PERFORMANCE ADVANTAGES

- ⦿ Consistently removes large quantities of non-emulsified organic contaminants to non-detectable levels or levels meeting regulatory codes.
- ⦿ Especially effective in removing oil and grease, total petroleum hydrocarbons, and dissolved hydrocarbons.
- ⦿ Eliminates or reduces waste volume, mobility and toxicity.
- ⦿ Uses no anthracite coal fillers
- ⦿ Enhanced coalescer system is comprised of oleophilic plates to maximize separation and minimize maintenance.
- ⦿ Removable plates simplifies routine cleaning.
- ⦿ Removes free floating oils and settleable solids for oil/ water mixtures to achieve 10 ppm effluent quality (or 15 ppm if specified).
- ⦿ Includes a 30-year internal/ external corrosion and structural warranty.

## APPLICATION

OWS-BP Oil/ Water Separators are used specifically for the removal of free floating oil, grease, and settleable oily coated solids from oil/ water discharges associated with many types of industrial facilities. Designed to remove oils with a specific gravity less than .95, high performance separators from 15 ppm oil/ grease discharge (Model OWS-BP)

## INTERCEPTORS

Oil drippings and spills from parking lots, driveways, oil terminals, airplane aprons, runways, and other vehicular traffic surfaces are being washed into our water supplies by rainwater, creating serious environmental concerns. OWS-BP Oil/ Water Separators are designed to meet EPA and local guidelines for rainwater runoff control.

## ELECTRONICS

Oil/ Water Separator monitoring and control systems can be configured to satisfy a wide range of customer requirements. Control panels, sensors, probes and gauges are available for double-wall and single-wall oil/water separator systems as well as for single-tank or multiple-tank installations. UIHT carries a full line of pump controls, inlet and outlet pumps, and waste oil pumps. We can package the right model with the proper electronics so when the tank arrives the only thing left to do is connect the piping.



# OPTIONAL FEATURES:

- Single-wall, Double-Wall Separator
- Manway Extension
- Tank Sump
- Cross-Flow Baffle
- Coalescer Plate Packs
- Oil Stop Valve
- Anchor Straps
- Deadman Anchor System

The unique cross flow design of the **OWS-BP** model results in the most efficient use of the corrugated plate pack.

## SEPARATOR DESIGN & SIZING

Since each site is unique, the most effective approach is to analyze each situation and design the system accordingly. UIHT engineering staff can help determine the best fit for your technical considerations and site specific needs:

- |                    |                                    |
|--------------------|------------------------------------|
| • Inlet flow rates | • Inlet/ Outlet Concentration      |
| • Effluent Quality | • Specific Gravity of Contaminants |

**OWS-BP** separators are sized primarily on flow rates. A complete list of flow rate plate pack options are available. Contact your UIHT representative for more information.

## Operation

After installation and commissioning, the idOil separator alarm system functions entirely independently and does not require constant monitoring.

The alarm information can be connected to automation systems through relays.

All of the system's connections and functions are described in the figure below and in more detail in the following sections.

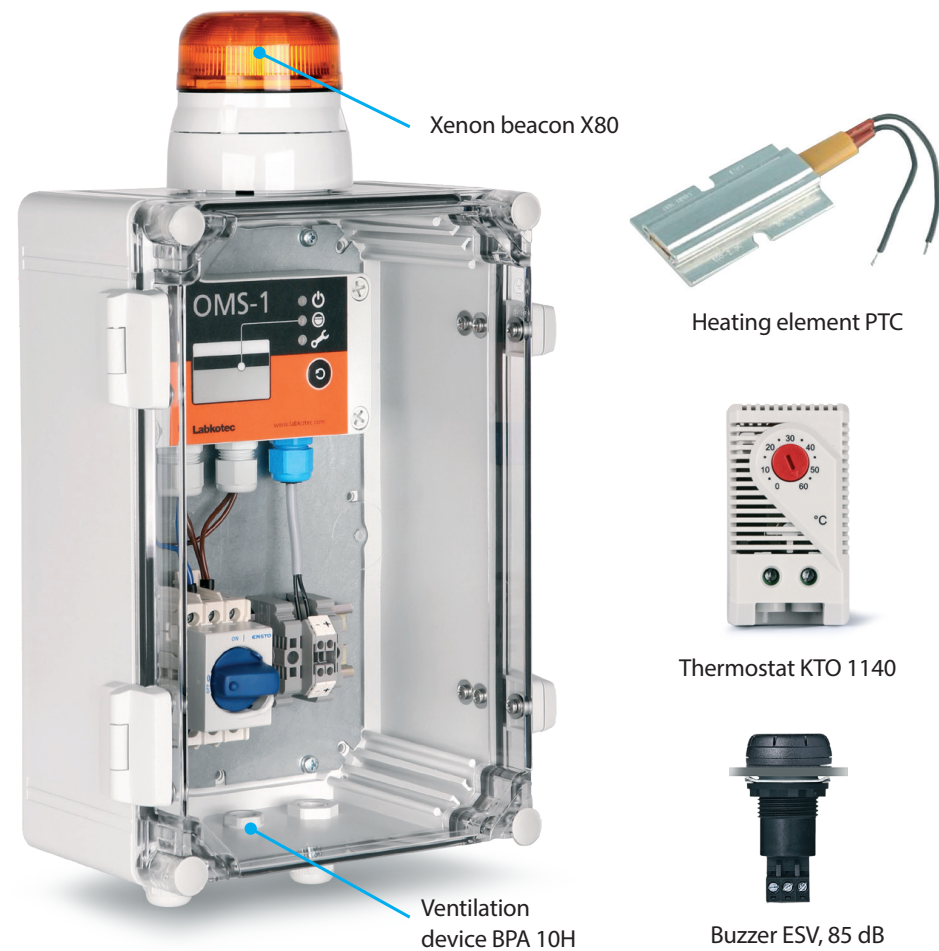
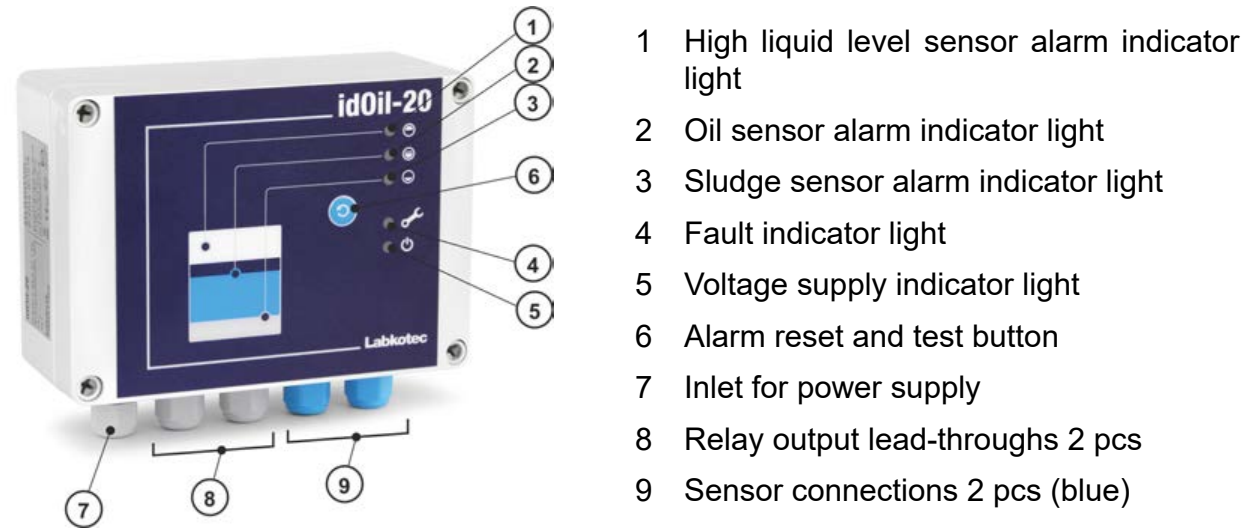

## Device operation

idOil® is an alarm system intended for monitoring liquid levels particularly in oil and sand separators. The system consists of the idOil control unit and the idOil sensors installed in the separator. The sensor cables can be extended with a cable connector or connection box.

One to three different types of digital idOil sensors can be connected to the control unit. The sensors can be used to monitor the following:

- High liquid level (idOil-LIQ high liquid level sensor)
- Oil layer detection (idOil-OIL oil sensor is for class IIA explosive liquids and idOil-OIL-S oil sensor is for class IIB explosive liquids)
- Sludge layer detection (idOil-SLU sludge sensor)

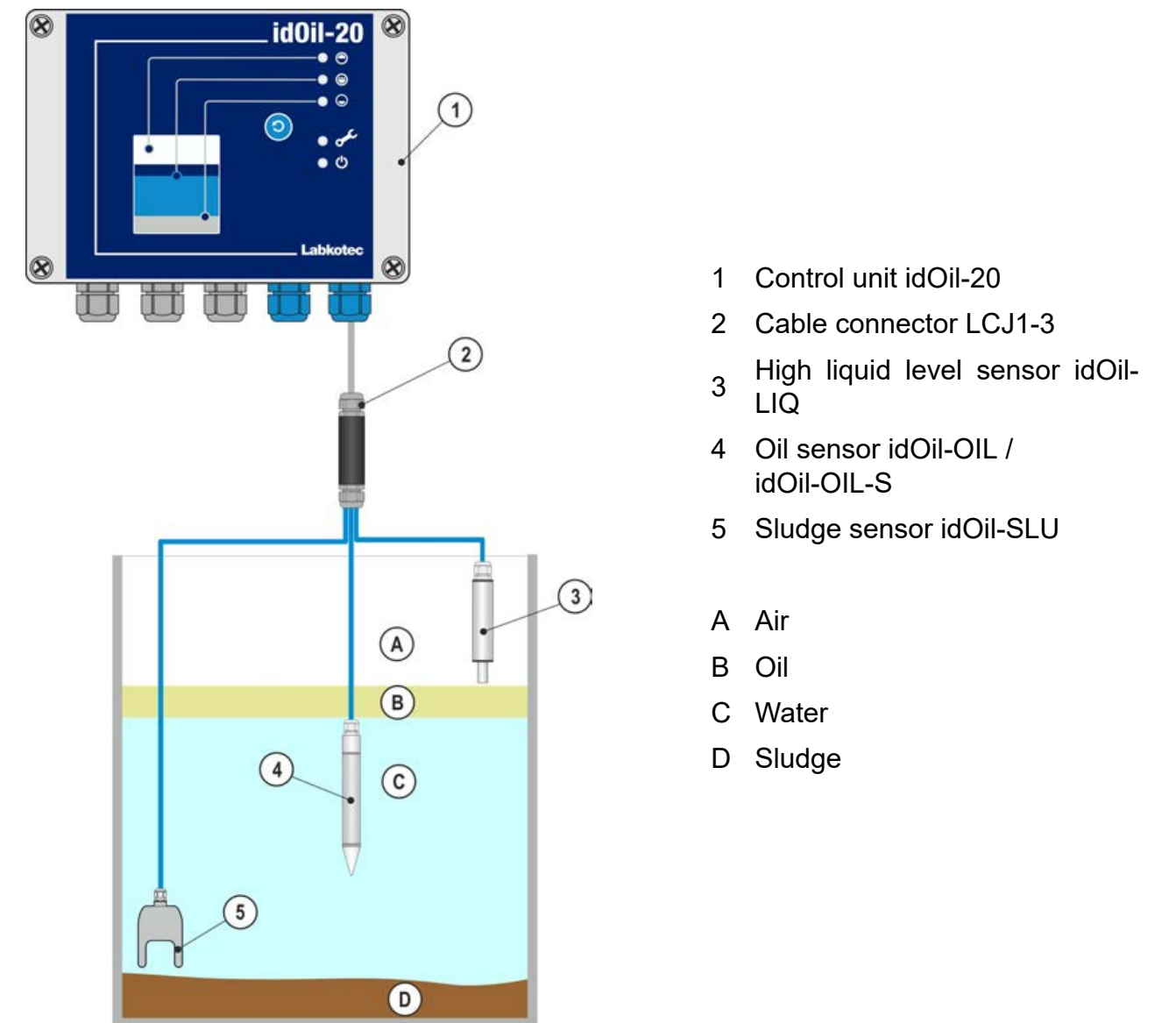

# ACCESSORIES FOR OIL/ WATER SEPARATORS

## HYDROCARBON, SAND AND SOLIDS DETECTION ALARM

- Equipment of level detection of hydrocarbon, oil and grease to install in grease and oil/ water separators with working temperatures (-20 to 50°C).
- Combined alarm system for oil, hydrocarbon, sand and solids.
- Detection of maximum level of oil and hydrocarbon on the water surface. To be installed in civil construction tanks or open top tanks.
- The probe is placed on three floats and detects an hydrocarbon layer up to 15 mm thick.



### Application

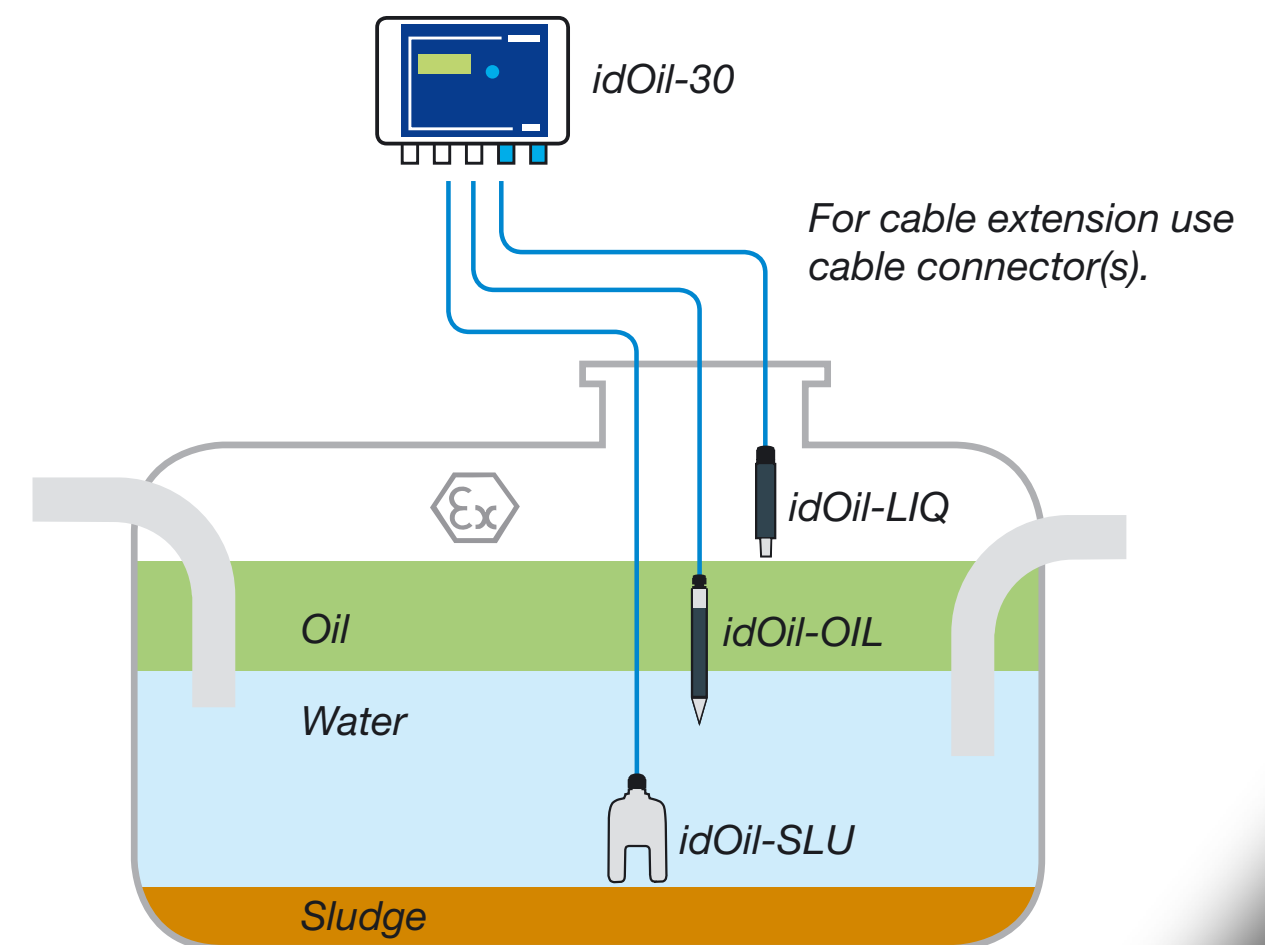

PARAMETER	PERFORMANCE OWS-BP MODEL
Stokes' Law	✓
ASTM D-4201	✓
UL 1316	✓
API 421	✓
USCG 46CFR 162.050	✓
15 PPM	✓
10 PPM	✓
UL 2215	✓
Intermittent Flow	✓
Continuous Flow	✓



# Oil Coalescer Filter Pack

Oil Coalescer Filter Pack are common oil separation systems due to their simplicity, modularity, and economic cost. Oil Coalescer Cabinet Filter have no moving parts, the configuration of plates simply enhances the coalescence of small droplets making them larger which is reflected in a faster rise rate according to Stoke's Law.

## GENERAL DESCRIPTION & PRINCIPLE OF WORK

Oil Coalescer Filter Pack is a device used to separate fluid mixtures into individual using the principle of coalescence. Coalescence is a process whereby fluid molecules agglomerate (come together) to form a larger whole. Coalescing filters can separate particulate components of mixtures at a comparable efficiencies. Any heavy solids present in the water being treated, or sludge, in theory should fall into the sludge compartment of the OWS unit. As oil droplets coalesce into to larger droplets, the buoyancy of the droplets increases. This is reflected in the known rise time for a given size of oil droplet. The more efficient the coalescence action of the media, the larger the oil droplets become. Oil Coalescer Filter Pack can be used to eliminate the need for chemicals in odor- control scrubbers, or improve oil removal efficiency in compact oil-water separators. The main function is to enhance the oil-water separation systems by capturing the small oil droplets of the oily water stream, enlarge their size, and help to float the oil to the top surface. Moreover, it can collect other suspended solids also that pass throw plates and enhance the water stream overall parameters.



# VESSEL CONSTRUCTION

## Manufacturing

UIHT Tank's Steel Oil/ Water Separators and Interceptors are second to none in design, quality and workmanship. The following information describes UIHT's standard vessel construction and fabrication options for steel separators and interceptors.

Standard 24", 30" and 36" diameter manways permit access to the inside of the vessel for maintenance from above. Double bolt ring manways for secondary containment sumps and custom, large rectangular access chambers to allow for total unconfined, unrestricted access from above, are also available.

**Forming Heads:** Sheet steel is cut with a rotary shear and flanged to form tank head.

**Rolling Steel:** Steel plates from 7 ga. to 1/2" are rolled to form the rigid shell of the vessel

**Fitting Components:** Flanged and threaded fittings, and other special components are fitted to the vessel, then welded in place.

**Protective Coating:** A tough, heavy duty dielectric coating of polyurethane covers the separator and seals it from the surrounding soil providing the first line of defense against stray current and galvanic corrosion.

**Welding:** All separators are sealed with a continuous exterior full-fillet lap weld.

**Coating:** Polyurethane, fiberglass reinforced polyester or other high-grade coatings are applied based on the separator's end use.

**Testing:** All separators are air tested for leaks at 5 psi. All seams are inspected to ensure weld integrity.

**Electrical Isolation:** UL-Listed dielectric nylon bushings or flange isolation kits are used in each opening to electrically isolate the separator from piping, preventing the entry of stray currents or galvanic action through piping connections.

# OWS-BP SYSTEM PROCESS

## How It Works . . .

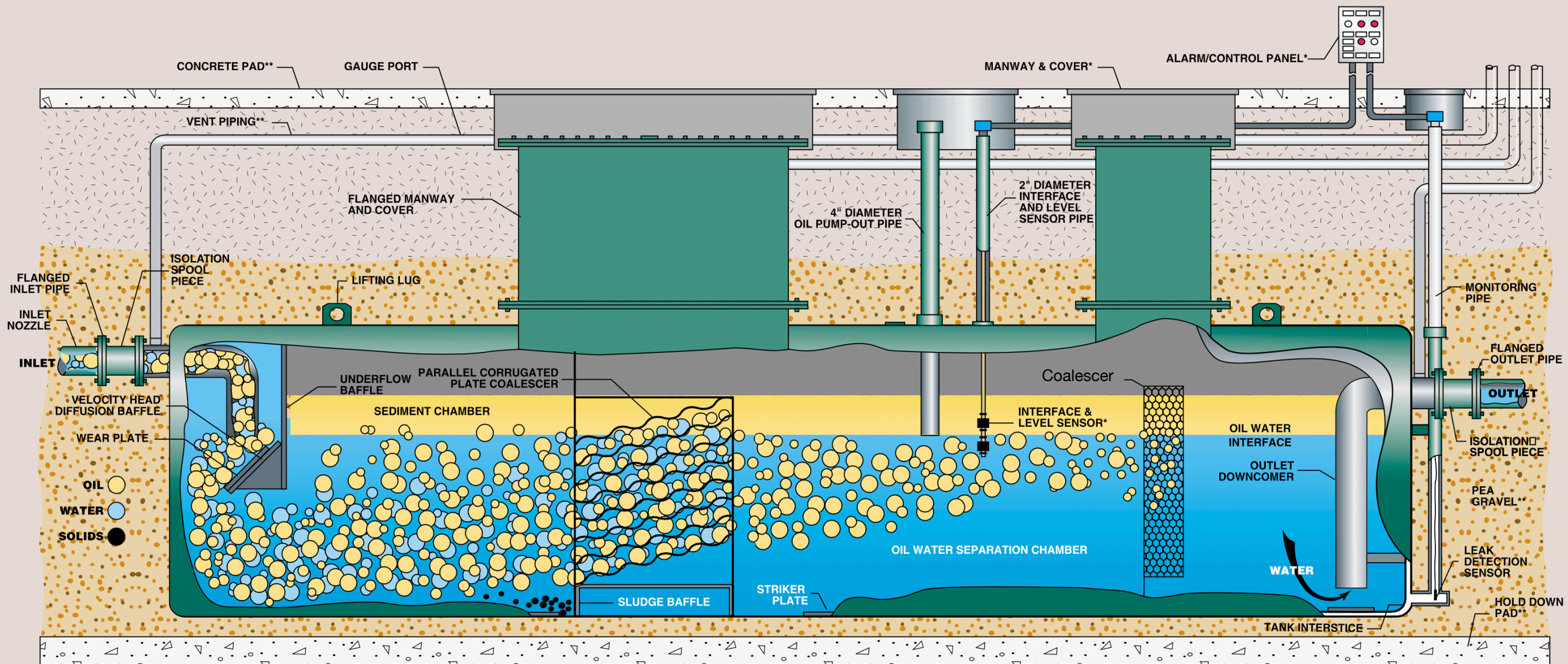

### Diffusion Baffle

- The velocity head diffusion baffle, located near the inlet of the separator, is designed to serve four basic functions:
  - To dissipate the velocity head, thereby improving the overall hydraulic characteristics of the separator.
  - To direct incoming flow downward and outward maximizing the use of the separator volume.
  - To reduce flow turbulence and to distribute the flow evenly over the separator's cross-sectional area.
  - To isolate inlet turbulence from the rest of the separator.

### Monitoring Systems

For easy and efficient operation and maintenance, an oil level sensor can sound an alarm at high oil levels so waste oil can be removed from the separator. Double-wall separators can be furnished with a leak detection system for the interstitial space. Additional monitoring equipment is available for oil or water level sensing, alarm and pump-out control.

### Internal Chambers

In the sediment chamber, heavy solids settle out, and concentrated oil slugs rise to the surface. As the oily water passes through the parallel corrugated plate coalescer (an inclined arrangement of parallel corrugated plates) the oil rises and coalesces into sheets on the underside of each plate. The oil then creeps up the plate surface, and breaks loose at the top in the form of large globules. These globules then rise rapidly to the surface of the separation chamber where the separated oil accumulates.

The effluent flows downward to the outlet downcomer, where it is discharged by gravity displacement from the lower regions of the separator.

The Oil/ Water Separator is buried and filled with water. Each separator includes a combination of baffles and coalescer packs, based on effluent requirements, to accelerate separation. Oil storm water enters through the inlet and gravity naturally settles heavier solids to the bottom of the tank as the oil floats to the top of the water level. The oily water then passes through the coalescing plates in a straight flow or cross flow direction depending on the tank model.

The configuration of the packs efficiently coalesces or joins oil droplets together forming larger masses of oil that rise to the surface where it accumulates and can be removed. Gravity displacement discharges the effluent through the outlet at a lower point in the tank chamber. Separator systems can also be equipped with electronic monitoring with high oil level alarms, oil stop valve, and control panel.

# PLATE COALESCER

Corrugated Plate Cabinet Filter are common oil separation systems due to their simplicity, modularity, and economic cost. Corrugated Parallel Plate Cabinet Oil Separator have no moving parts, the configuration of plates simply enhances the coalescence of small droplets making them larger which is reflected in a faster rise rate according to Stoke's Law.

Moreover, a proper arrangement of inclined plates will force the fluid stream to rise while passing between plates, decreasing the rise distance of oil droplets. In contrast, solids gathered between plates will sink by gravity moving backward ideally towards the sludge hopper. In addition to the above, this simple process results in a very low failure possibility and requires minimum efforts for maintenance as plates can be removed individually for cleaning and replacement.

The CPPC main function is to enhance the oil-water separation systems by capturing the small oil droplets of the oily water stream, enlarge their size, and help to float the oil to the top surface. Moreover, the Corrugated Plate Separator can collect other suspended solids also that pass through plates and enhance the water stream overall parameters.

PLATE COALESCER  
HIGH PERFORMANCE

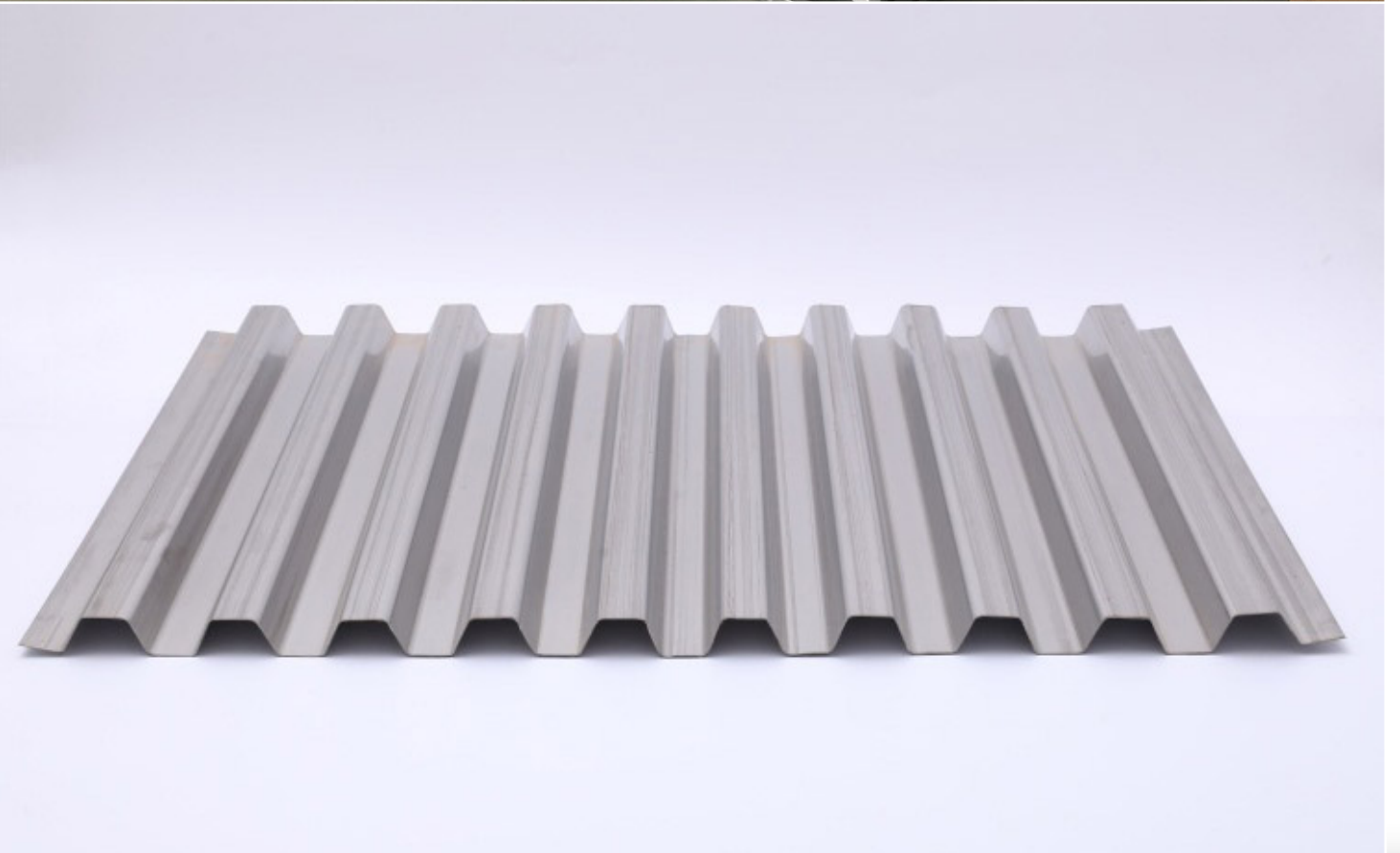



# VESSEL CONSTRUCTION

## Single-wall

Standard single-wall vessels are constructed of mild carbon or stainless steel meeting ASTM specifications. Material thicknesses from 7 gauge to 1/2" can be specified. Superior "ribbed" strength is achieved with continuous exterior full-fillet lap welds, employing a minimum 1/2" overlap on both head and shell joints. All separators and interceptors are factory air tested for leaks at 5 psi.

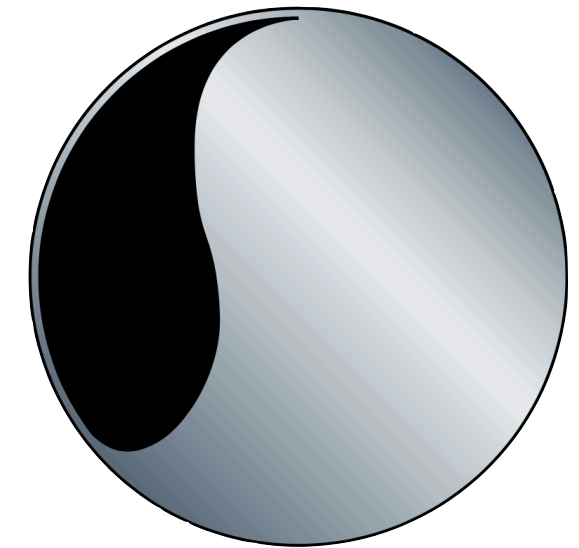

Single-wall

## Double-wall

Double-wall vessels are constructed by wrapping a secondary steel wall completely around the primary vessel. Each double-wall vessel is constructed employing the same basic fabrication techniques as are used on single-wall vessels. The area between the vessel walls, known as the interstice, can be monitored with a leak detection system installed in the monitor tube, located on the vessel head.

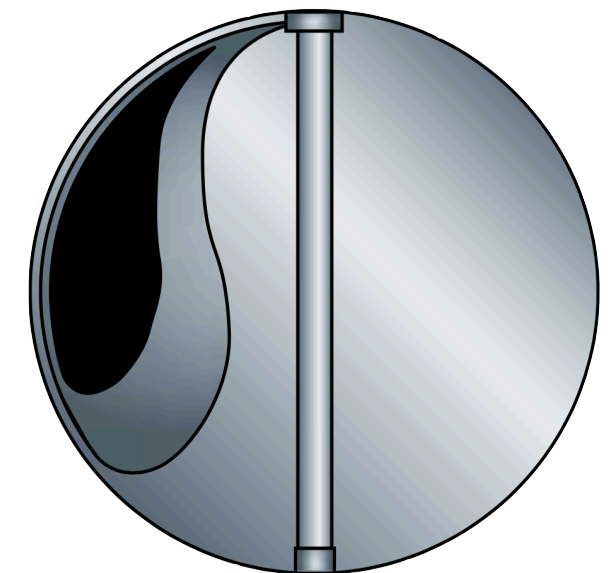

Double-wall

# OWS-BP MODEL

UNDERGROUND OIL/ WATER SEPARATORS  
BYPASS TYPE



UNITED INTERNATIONAL  
HYDRO ENG. TECH





UNITED INTERNATIONAL  
HYDRO ENG. TECH

[www.uihydro.com](http://www.uihydro.com) - [eng@uihydro.com](mailto:eng@uihydro.com)



[www.basiiia.com](http://www.basiiia.com) - [sales@basiiia.com](mailto:sales@basiiia.com)