

C212



WHEEL BALANCER FOR CARS, HEAVY-DUTY TRUCKS AND BUSES

C212 WHEEL BALANCER

for truck wheels, heavy-duty truck service shops, municipalities, fleet truck tire service companies and all commercial truck tires.



CEMB[®] USA

C212

- Electro-pneumatic stationary brake
- **MULTIFUNCTIONAL DIGITAL PANEL** with Direct Weight Placement program and Behind Spoke (Split) mode
- **STATIC UNBALANCE ALWAYS DISPLAYED ON SCREEN** for full-time accuracy
- **AUTOMATIC ARM 2D** to measure automatically distance and diameter
- 51" wheel guard
- **PNEUMATIC LIFT** integrated, for wheels up to 550 lbs (250 Kg)
- Made in ITALY

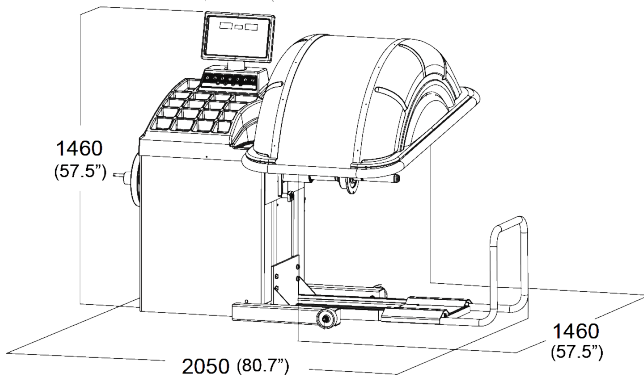

Power requirements	110 VAC, 50/60 Hz, 1 ph
Balancing speed	70 rpm (truck) - 100 rpm (car)
Measuring cycle	10 - 20 s
Unbalance resolution	0.25 oz (10 g) truck mode - 0.01 oz (1 g) car mode
Rim width setting range	1.5" - 20" (40 - 510 mm)
Rim diameter setting range	10" - 30" (265 - 765 mm)
Max. tire diameter	51" (1,295 mm)
Max. wheel weight	550 lbs (250 Kg)
Shaft diameter	40 mm
Machine weight	615 lbs (280 Kg)

STANDARD ACCESSORIES

UC 215HW 41FF59368



MANUAL LOCKING



OPTIONAL ACCESSORIES

SR215/2 STAR ADAPT. - 41FF67879

ACCESSORY RACK - 41FF03151

For a complete list of accessories and more information visit our website www.cemb-usa.com

CEMB[®] USA

CEMB[®] USA - BL Systems Inc.
2873 Ramsey Road, Gainesville GA 30501 - USA
Phone +1 (678) 717-1050 - sales@cemb-usa.com
www.cemb-usa.com

DISTRIBUTED BY

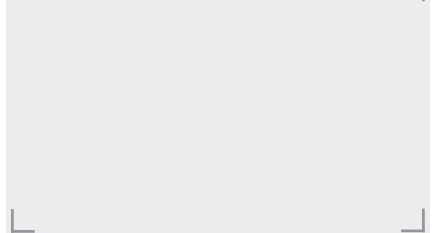

Because of continuing technological advancements, specifications, models and options are subject to change without notice.