

**MANUFACTURING  
DISTRIBUTING**

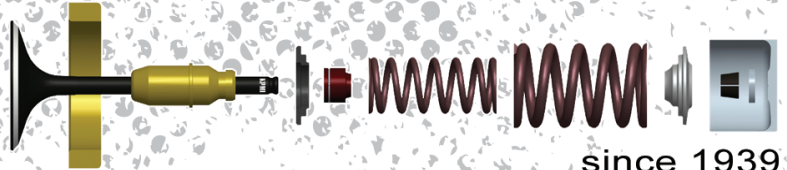

**2021**

HIGH PERFORMANCE VALVETRAIN



since 1939

January 12, 2021

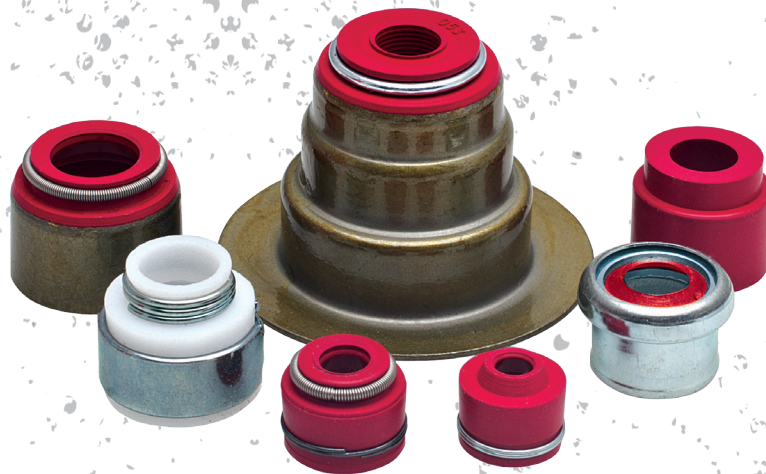

**VALVE GUIDE SEAL CATALOG**

**MANUFACTURING  
DISTRIBUTING**

**WWW.KPMI.US**



**f t** Follow us on



# LARRY MCBRIDE

Top Fuel World Champion



# SAMMY HALBERT

Flattrack Grand National Champion



# IAN KING











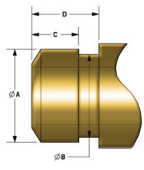

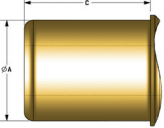
European Top Fuel World Champion

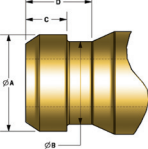
# KPMI® VALVE STEM SEALS

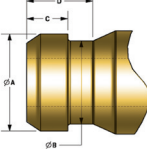
**USED BY THE TOP RACERS  
IN THE WORLD**

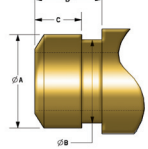
**INSIST ON THE RED ONES!**

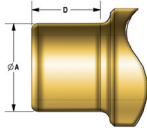
KPMI® has been working for the past ten years designing and developing a premium line of “RED” valve stem seals. The KPMI® engineering team were given strict guidelines to develop seals that are made from premium materials, provide optimum fitment, offer maximum life and allow for maximum lift. By limiting material choices to High Temperature Viton® and Teflon®, the entire KPMI® Red Seal line are resistant to high temperatures, petroleum products and corrosive gasses that typically break down lesser quality seals. KPMI® seals retain their ability to seal in situations that other materials harden and deform, which then allows oil to bypass the seal and enter into the combustion chamber, causing detonation, carbon build up and a loss of power. Don't complete you're next rebuild without a set of the “Red Ones”.

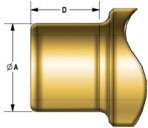
<p><b>KPMI® Seal Style 1</b></p>			<p><b>KPMI® Seal Style 3</b></p>		
<p><b>KPMI® Seal Style 2</b></p>			<p><b>KPMI® Seal Style 5</b></p>		
<p><b>KPMI® Seal Style 4</b></p>			<p><b>KPMI® Seal Style 7</b></p>		
<p><b>KPMI® Seal Style 6</b></p>			<p><b>KPMI® Seal Designs Offer a Diagram and Dimentions So You Can Insure For a Proper Fit.</b></p>		

All KPMI® seals are conveniently packaged in quantities of: 4, 8, 16, 50, and 100. Value added savings have been built into the 16, 50, and 100 quantity packs with 10, 15, and 20% savings respectively. All 5-valve motors have been kitted and when a model has unique stem diameters between intake and exhaust, they too have been kitted. In the following pages of this brochure you can find the comprehensive offering of valve stem seals KPMI® has to offer.

## Seal Style 1 - Solid Viton

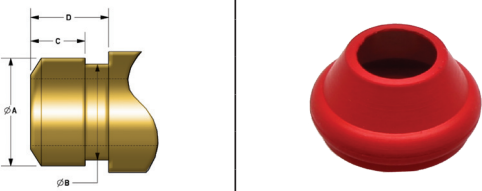
Stem Diameter	O.L.	Seal O.D.	Designed for these guide specs				OEM REF.
			A	B	C	D	
<b>8.0mm</b>	0.285"	0.555"	0.466"-0.475"	0.411"-0.430"	0.040"	0.135"	764.1.013.1A
			Part Number		Quantity		
		<b>71043-4</b>		Pkg. of 4			
		<b>71043-8</b>		Pkg. of 8			
		<b>71043-16</b>		Pkg. of 16			
		<b>71043-50</b>		Pkg. of 50			
		<b>71043-100</b>		Pkg. of 100			

## Seal Style 1 - Solid Viton

Stem Diameter	O.L.	Seal O.D.	Designed for these guide specs				OEM REF.
			A	B	C	D	
<b>5/16"</b>	0.465"	0.550"	0.500"±0.010"	0.445"	0.230"	0.280"	---
			Part Number		Quantity		
		<b>71012-4</b>		Pkg. of 4			
		<b>71012-8</b>		Pkg. of 8			
		<b>71012-16</b>		Pkg. of 16			
		<b>71012-50</b>		Pkg. of 50			
		<b>71012-100</b>		Pkg. of 100			

## Seal Style 2 - Solid Viton w/ Tension Spring

Stem Diameter	O.L.	Seal O.D.	Designed for these guide specs				OEM REF.
			A	B	C	D	
<b>4.0mm</b>	0.310"	0.380"	0.315"±0.005"	0.270"	0.120"	0.235"	12209-KT7-013
			Part Number		Quantity		
		<b>71013-4</b>		Pkg. of 4			
		<b>71013-8</b>		Pkg. of 8			
		<b>71013-16</b>		Pkg. of 16			
		<b>71013-50</b>		Pkg. of 50			
		<b>71013-100</b>		Pkg. of 100			



## Seal Style 2 - Solid Viton w/ Tension Spring

Stem Diameter	O.L.	Seal O.D.	Designed for these guide specs				OEM REF.
			A	B	C	D	
<b>5.5mm</b>	0.330"	0.455"	0.365"±0.002"	0.325"	0.120"	0.235"	51Y-12119-00-00
			Part Number		Quantity		
		<b>71040-4</b>		Pkg. of 4			
		<b>71040-8</b>		Pkg. of 8			
		<b>71040-16</b>		Pkg. of 16			
		<b>71040-50</b>		Pkg. of 50			
		<b>71040-100</b>		Pkg. of 100			

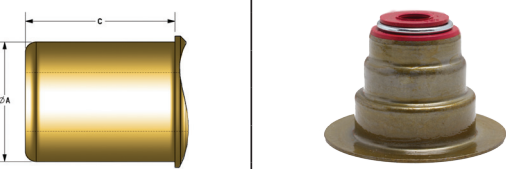

## Seal Style 3 - Solid Viton w/ Metal Jacket & Integral Spring Base

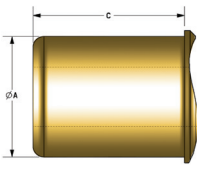
Stem Diameter	O.L.	Seal O.D.	Designed for these guide specs			Spring Shoulder Dia.	OEM REF.
			A	B	C		
<b>7.0mm</b>	0.974"	1.457"	0.560"±0.005"	---	0.700"	0.970"	18094-02A
			Part Number		Quantity		
		<b>71030-4</b>		Pkg. of 4			
		<b>71030-8</b>		Pkg. of 8			
		<b>71030-16</b>		Pkg. of 16			
		<b>71030-50</b>		Pkg. of 50			
		<b>71030-100</b>		Pkg. of 100			

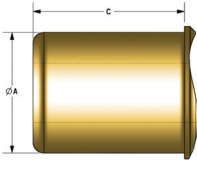

### Seal Style 3 - Solid Viton w/ Metal Jacket & Integral Spring Base

Stem Diameter	O.L.	Seal O.D.	Designed for these guide specs			Spring Shoulder Dia.	OEM REF.
			A	B	C		
5.5mm	0.630"	1.043"	A	B	C	0.697"	3610212
			0.435 ± 0.005	---	0.480"		
			Part Number			Quantity	
			71048-4			Pkg. of 4	
			71048-8			Pkg. of 8	
			71048-16			Pkg. of 16	
			71048-50			Pkg. of 50	
			71048-100			Pkg. of 100	

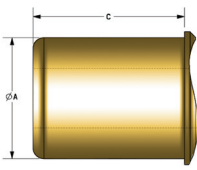

### Seal Style 3 - Solid Viton w/ Metal Jacket & Integral Spring Base

Stem Diameter	O.L.	Seal O.D.	Designed for these guide specs			Spring Shoulder Dia.	OEM REF.
			A	B	C		
5.0mm	0.460"	0.975"	A	B	C	0.674"	420431671
			0.355 ± 0.005	---	0.290"		
			Part Number			Quantity	
			71047-4			Pkg. of 4	
			71047-8			Pkg. of 8	
			71047-16			Pkg. of 16	
			71047-50			Pkg. of 50	
			71047-100			Pkg. of 100	

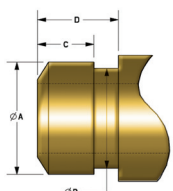

### Seal Style 3 - Solid Viton w/ Metal Jacket & Integral Spring Base

Stem Diameter	O.L.	Seal O.D.	Designed for these guide specs			Spring Shoulder Dia.	OEM REF.
			A	B	C		
6.0mm	0.712"	1.170"	A	B	C	0.707"	18100044
			0.475"±0.005"	---	0.545"		
			Part Number			Quantity	
			71046-4			Pkg. of 4	
			71046-8			Pkg. of 8	
			71046-16			Pkg. of 16	
			71046-50			Pkg. of 50	
			71046-100			Pkg. of 100	

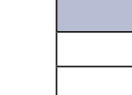

### Seal Style 4 - Solid Viton w/ Choker & Tension Spring

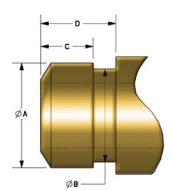
Stem Diameter	O.L.	Seal O.D.	Designed for these guide specs				OEM REF.
			A	B	C	D	
4.5mm	0.331"	0.370"	A	B	C	D	12209-ML0-722
			0.321"±0.005"	0.281"	0.120"	0.240"	
			Part Number			Quantity	
			71014-4			Pkg. of 4	
			71014-8			Pkg. of 8	
			71014-16			Pkg. of 16	
			71014-50			Pkg. of 50	
			71014-100			Pkg. of 100	

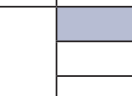

### Seal Style 4 - Solid Viton w/ Choker & Tension Spring

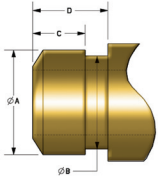
Stem Diameter	O.L.	Seal O.D.	Designed for these guide specs				OEM REF.
			A	B	C	D	
5.0mm	0.350"	0.405"	A	B	C	D	09289-05011
			0.340"±0.005"	0.303"	0.125"	0.230"	
			Part Number			Quantity	
			71015-4			Pkg. of 4	
			71015-8			Pkg. of 8	
			71015-16			Pkg. of 16	
			71015-50			Pkg. of 50	
			71015-100			Pkg. of 100	

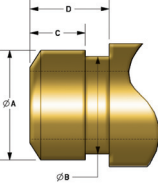

### Seal Style 4 - Solid Viton w/ Choker & Tension Spring

Stem Diameter	O.L.	Seal O.D.	Designed for these guide specs				OEM REF.
5.5mm	0.320"	0.440"	A	B	C	D	12209-422-005
			0.358"±0.005"	0.320"	0.115"	0.225"	
		Part Number		Quantity			
		71016-4		Pkg. of 4			
		71016-8		Pkg. of 8			
		71016-16		Pkg. of 16			
		71016-50		Pkg. of 50			
		71016-100		Pkg. of 100			

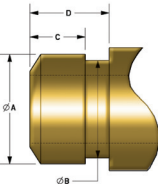

### Seal Style 4 - Solid Viton w/ Choker & Tension Spring

Stem Diameter	O.L.	Seal O.D.	Designed for these guide specs				OEM REF.
6.5mm	0.353"	0.560"	A	B	C	D	12209-300-003
			0.475"±0.005"	0.415"	0.115"	0.260"	
		Part Number		Quantity			
		71018-4		Pkg. of 4			
		71018-8		Pkg. of 8			
		71018-16		Pkg. of 16			
		71018-50		Pkg. of 50			
		71018-100		Pkg. of 100			

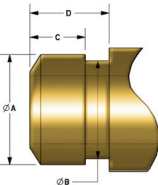

### Seal Style 4 - Solid Viton w/ Choker & Tension Spring

Stem Diameter	O.L.	Seal O.D.	Designed for these guide specs				OEM REF.
7.0mm	0.374"	0.560"	A	B	C	D	92049-016
			0.475"±0.005"	0.430"	0.115"	0.240"	
		Part Number		Quantity			
		71019-4		Pkg. of 4			
		71019-8		Pkg. of 8			
		71019-16		Pkg. of 16			
		71019-50		Pkg. of 50			
		71019-100		Pkg. of 100			

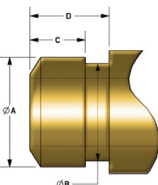

### Seal Style 5 - Solid Viton w/ Metal Jacket & Choker Spring

Stem Diameter	O.L.	Seal O.D.	Designed for these guide specs				OEM REF.
4.0mm	0.320"	0.355"	A	B	C	D	---
			0.285"±0.002"	0.245"	0.120"	0.215"	
		Part Number		Quantity			
		71039-4		Pkg. of 4			
		71039-8		Pkg. of 8			
		71039-16		Pkg. of 16			
		71039-50		Pkg. of 50			
		71039-100		Pkg. of 100			
Note: The 71039 seals do not have a choker spring.							

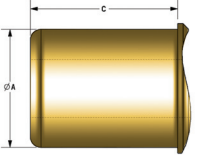

### Seal Style 5 - Solid Viton w/ Metal Jacket & Choker Spring

Stem Diameter	O.L.	Seal O.D.	Designed for these guide specs				OEM REF.
5.0mm	0.320"	0.435"	A	B	C	D	77036027000
			0.305"±0.002"	0.265"	0.100"	0.195"	
		Part Number		Quantity			
		71041-4		Pkg. of 4			
		71041-8		Pkg. of 8			
		71041-16		Pkg. of 16			
		71041-50		Pkg. of 50			
		71041-100		Pkg. of 100			

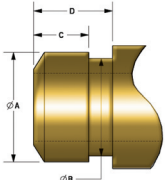

### Seal Style 5 - Solid Viton w/ Metal Jacket & Choker Spring

Stem Diameter	O.L.	Seal O.D.	Designed for these guide specs				OEM REF.
5.5mm	0.540"	0.524"	A	B	C	D	---
			0.435"±0.002"	---	---	0.410"	
		Part Number			Quantity		
		71038-4			Pkg. of 4		
		71038-8			Pkg. of 8		
		71038-16			Pkg. of 16		
		71038-50			Pkg. of 50		
71038-100			Pkg. of 100				

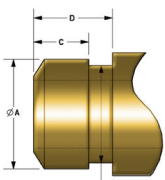

### Seal Style 5 - Solid Viton w/ Metal Jacket & Choker Spring

Stem Diameter	O.L.	Seal O.D.	Designed for these guide specs				OEM REF.
5.5mm	0.315"	0.455"	A	B	C	D	420430420
			0.325"±0.002"	0.310"	0.110"	0.220"	
		Part Number			Quantity		
		71042-4			Pkg. of 4		
		71042-8			Pkg. of 8		
		71042-16			Pkg. of 16		
		71042-50			Pkg. of 50		
71042-100			Pkg. of 100				

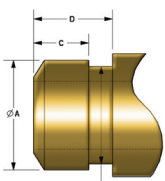

### Seal Style 5 - Solid Viton w/ Metal Jacket & Choker Spring

Stem Diameter	O.L.	Seal O.D.	Designed for these guide specs				OEM REF.
6.0mm	0.371"	0.480"	A	B	C	D	5H0-12119-00-00
			0.385"±0.002"	0.341"	0.120"	0.255"	
		Part Number			Quantity		
		71017-4			Pkg. of 4		
		71017-8			Pkg. of 8		
		71017-16			Pkg. of 16		
		71017-50			Pkg. of 50		
71017-100			Pkg. of 100				

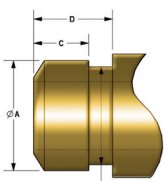

### Seal Style 5 - Solid Viton w/ Metal Jacket & Choker Spring

Stem Diameter	O.L.	Seal O.D.	Designed for these guide specs				OEM REF.
6.0mm	0.400"	0.560"	A	B	C	D	711230510
			0.435"±0.002"	0.400"	0.120"	0.285"	
		Part Number			Quantity		
		71025-4			Pkg. of 4		
		71025-8			Pkg. of 8		
		71025-16			Pkg. of 16		
		71025-50			Pkg. of 50		
71025-100			Pkg. of 100				

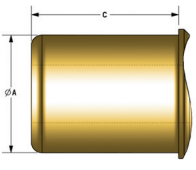

### Seal Style 5 - Solid Viton w/ Metal Jacket & Choker Spring

Stem Diameter	O.L.	Seal O.D.	Designed for these guide specs				OEM REF.
6.0mm	0.315"	0.520"	A	B	C	D	59036027000
			0.435"±0.002"	0.395"	0.120"	0.210"	
		Part Number			Quantity		
		71029-4			Pkg. of 4		
		71029-8			Pkg. of 8		
		71029-16			Pkg. of 16		
		71029-50			Pkg. of 50		
71029-100			Pkg. of 100				

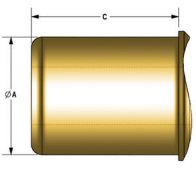

### Seal Style 5 - Solid Viton w/ Metal Jacket & Choker Spring

Stem Diameter	O.L.	Seal O.D.	Designed for these guide specs				OEM REF.
			A	B	C	D	
<b>6.0mm</b>	0.524"	0.615"	A	B	C	D	---
			0.495"±0.002"	---	---	0.385"	
		Part Number		Quantity			
		<b>71031-4</b>		Pkg. of 4			
		<b>71031-8</b>		Pkg. of 8			
		<b>71031-16</b>		Pkg. of 16			
		<b>71031-50</b>		Pkg. of 50			
		<b>71031-100</b>		Pkg. of 100			

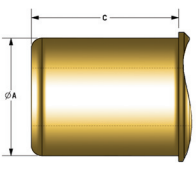

### Seal Style 5 - Solid Viton w/ Metal Jacket & Choker Spring

Stem Diameter	O.L.	Seal O.D.	Designed for these guide specs				OEM REF.
			A	B	C	D	
<b>6.0mm</b>	0.394"	0.555"	A	B	C	D	---
			0.447"±0.002"	---	---	0.265"	
		Part Number		Quantity			
		<b>71037-4</b>		Pkg. of 4			
		<b>71037-8</b>		Pkg. of 8			
		<b>71037-16</b>		Pkg. of 16			
		<b>71037-50</b>		Pkg. of 50			
		<b>71037-100</b>		Pkg. of 100			

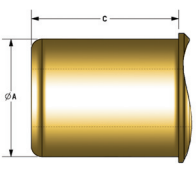

### Seal Style 5 - Solid Viton w/ Metal Jacket & Choker Spring

Stem Diameter	O.L.	Seal O.D.	Designed for these guide specs				OEM REF.
			A	B	C	D	
<b>7.0mm</b>	0.517"	0.550"	A	B	C	D	022-1516
			0.435"±0.002"	---	---	0.310"	
		Part Number		Quantity			
		<b>71026-4</b>		Pkg. of 4			
		<b>71026-8</b>		Pkg. of 8			
		<b>71026-16</b>		Pkg. of 16			
		<b>71026-50</b>		Pkg. of 50			
		<b>71026-100</b>		Pkg. of 100			

### Seal Style 5 - Solid Viton w/ Metal Jacket & Choker Spring

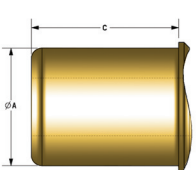

Stem Diameter	O.L.	Seal O.D.	Designed for these guide specs				OEM REF.
			A	B	C	D	
<b>7.0mm</b>	0.510"	0.665"	A	B	C	D	---
			0.560"±0.002"	---	---	0.375"	
		Part Number		Quantity			
		<b>71028-4</b>		Pkg. of 4			
		<b>71028-8</b>		Pkg. of 8			
		<b>71028-16</b>		Pkg. of 16			
		<b>71028-50</b>		Pkg. of 50			
		<b>71028-100</b>		Pkg. of 100			

### Seal Style 5 - Solid Viton w/ Metal Jacket & Choker Spring



Stem Diameter	O.L.	Seal O.D.	Designed for these guide specs				OEM REF.
			A	B	C	D	
<b>7.0mm</b>	0.360"	0.520"	A	B	C	D	764.1.087.1A
			0.383"-0.389"	---	---	0.255"	
		Part Number		Quantity			
		<b>71044-4</b>		Pkg. of 4			
		<b>71044-8</b>		Pkg. of 8			
		<b>71044-16</b>		Pkg. of 16			
		<b>71044-50</b>		Pkg. of 50			
		<b>71044-100</b>		Pkg. of 100			

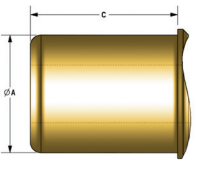

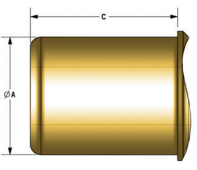

### Seal Style 5 - Solid Viton w/ Metal Jacket & Choker Spring

Stem Diameter	O.L.	Seal O.D.	Designed for these guide specs				OEM REF.
8.0mm	0.374"	0.598"	A	B	C	D	E6TZ6571A
			0.472"±0.002"	---	---	0.265"	
		Part Number			Quantity		
		71027-4			Pkg. of 4		
		71027-8			Pkg. of 8		
		71027-16			Pkg. of 16		
		71027-50			Pkg. of 50		
		71027-100			Pkg. of 100		

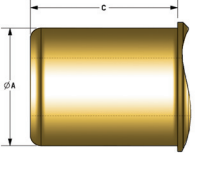

### Seal Style 5 - Solid Viton w/ Metal Jacket & Choker Spring

Stem Diameter	O.L.	Seal O.D.	Designed for these guide specs				OEM REF.
5/16"	0.412"	0.566"	A	B	C	D	35178930
			0.420"±0.002"	---	---	0.275"	
		Part Number			Quantity		
		71010-4			Pkg. of 4		
		71010-8			Pkg. of 8		
		71010-16			Pkg. of 16		
		71010-50			Pkg. of 50		
		71010-100			Pkg. of 100		

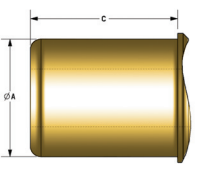

### Seal Style 5 - Solid Viton w/ Metal Jacket & Choker Spring

Stem Diameter	O.L.	Seal O.D.	Designed for these guide specs				OEM REF.		
5/16"	0.514"	0.671"	A	B	C	D	---		
			0.530"±0.002"	---	---	0.330"			
					Part Number			Quantity	
					71045-4			Pkg. of 4	
					71045-8			Pkg. of 8	
					71045-16			Pkg. of 16	
					71045-50			Pkg. of 50	
					71045-100			Pkg. of 100	

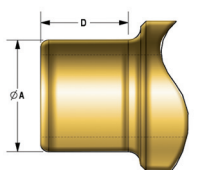

### Seal Style 5 - Solid Viton w/ Metal Jacket & Choker Spring

Stem Diameter	O.L.	Seal O.D.	Designed for these guide specs				OEM REF.
3/8"	0.516"	0.661"	A	B	C	D	---
			0.562"±0.002"	---	---	0.375"	
		Part Number			Quantity		
		71011-4			Pkg. of 4		
		71011-8			Pkg. of 8		
		71011-16			Pkg. of 16		
		71011-50			Pkg. of 50		
		71011-100			Pkg. of 100		

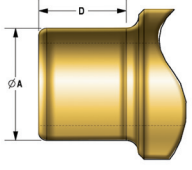

### Seal Style 6 - Solid PC w/ Metal Band & Choker Spring

Stem Diameter	O.L.	Seal O.D.	Designed for these guide specs				OEM REF.
5/16"	0.386"	0.512"	A	B	C	D	5403212
			0.425"±0.002"	---	---	0.235"	
		Part Number			Quantity		
		71003-4			Pkg. of 4		
		71003-8			Pkg. of 8		
		71003-16			Pkg. of 16		
		71003-50			Pkg. of 50		
		71003-100			Pkg. of 100		

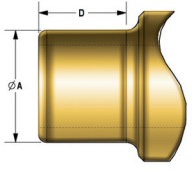

### Seal Style 6 - Solid PC w/ Metal Band & Choker Spring

Stem Diameter	O.L.	Seal O.D.	Designed for these guide specs				OEM REF.
5/16"	0.510"	0.600"	A	B	C	D	---
			0.500"±0.002"	---	---	0.365"	
		Part Number		Quantity			
		71006-4		Pkg. of 4			
		71006-8		Pkg. of 8			
		71006-16		Pkg. of 16			
		71006-50		Pkg. of 50			
		71006-100		Pkg. of 100			

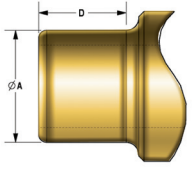

### Seal Style 6 - Solid PC w/ Metal Band & Choker Spring

Stem Diameter	O.L.	Seal O.D.	Designed for these guide specs				OEM REF.
5/16"	0.517"	0.510"	A	B	C	D	8921209
			0.415"±0.005"	---	---	0.350"	
		Part Number		Quantity			
		71008-4		Pkg. of 4			
		71008-8		Pkg. of 8			
		71008-16		Pkg. of 16			
		71008-50		Pkg. of 50			
		71008-100		Pkg. of 100			

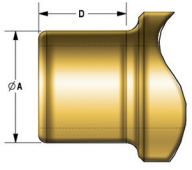

### Seal Style 6 - Solid PC w/ Metal Band & Choker Spring

Stem Diameter	O.L.	Seal O.D.	Designed for these guide specs				OEM REF.
5/16"	0.506"	0.632"	A	B	C	D	---
			0.530"±0.002"	---	---	0.365"	
		Part Number		Quantity			
		71009-4		Pkg. of 4			
		71009-8		Pkg. of 8			
		71009-16		Pkg. of 16			
		71009-50		Pkg. of 50			
		71009-100		Pkg. of 100			

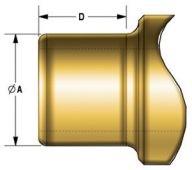

### Seal Style 6 - Solid PC w/ Metal Band & Choker Spring

Stem Diameter	O.L.	Seal O.D.	Designed for these guide specs				OEM REF.
11/32"	0.510"	0.596"	A	B	C	D	---
			0.500"±0.002"	---	---	0.360"	
		Part Number		Quantity			
		71005-4		Pkg. of 4			
		71005-8		Pkg. of 8			
		71005-16		Pkg. of 16			
		71005-50		Pkg. of 50			
		71005-100		Pkg. of 100			

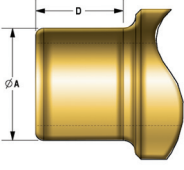

### Seal Style 6 - Solid PC w/ Metal Band & Choker Spring

Stem Diameter	O.L.	Seal O.D.	Designed for these guide specs				OEM REF.
11/32"	0.514"	0.654"	A	B	C	D	---
			0.562"±0.002"	---	---	0.345"	
		Part Number		Quantity			
		71007-4		Pkg. of 4			
		71007-8		Pkg. of 8			
		71007-16		Pkg. of 16			
		71007-50		Pkg. of 50			
		71007-100		Pkg. of 100			

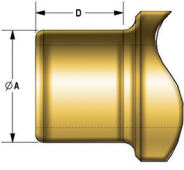

### Seal Style 6 - Solid PC w/ Metal Band & Choker Spring

Stem Diameter	O.L.	Seal O.D.	Designed for these guide specs				OEM REF.
3/8"	0.502"	0.626"	A	B	C	D	---
			0.530"±0.002"	---	---	0.350"	
		Part Number			Quantity		
		71001-4			Pkg. of 4		
		71001-8			Pkg. of 8		
		71001-16			Pkg. of 16		
		71001-50			Pkg. of 50		
		71001-100			Pkg. of 100		

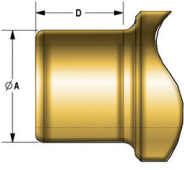

### Seal Style 6 - Solid PC w/ Metal Band & Choker Spring

Stem Diameter	O.L.	Seal O.D.	Designed for these guide specs				OEM REF.
3/8"	0.518"	0.650"	A	B	C	D	---
			0.562"±0.002"	---	---	0.365"	
		Part Number			Quantity		
		71002-4			Pkg. of 4		
		71002-8			Pkg. of 8		
		71002-16			Pkg. of 16		
		71002-50			Pkg. of 50		
		71002-100			Pkg. of 100		

### Seal Style 6 - Solid PC w/ Metal Band & Choker Spring

Stem Diameter	O.L.	Seal O.D.	Designed for these guide specs				OEM REF.
3/8"	0.507"	0.600"	A	B	C	D	---
			0.500"±0.002"	---	---	0.355"	
		Part Number			Quantity		
		71004-4			Pkg. of 4		
		71004-8			Pkg. of 8		
		71004-16			Pkg. of 16		
		71004-50			Pkg. of 50		
		71004-100			Pkg. of 100		

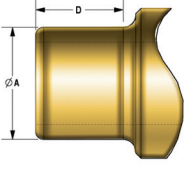
### Seal Style 7 - H.D. OEM Style Solid Teflon w/ a Metal Jacket

Stem Diameter	O.L.	Seal O.D.	Designed for these guide specs				OEM REF.
5/16"	0.385"	0.565"	A	B	C	D	18001-83B
			0.420"±0.002"	---	---	0.315"	
		Part Number			Quantity		
		71032-4			Pkg. of 4		
		71032-8			Pkg. of 8		
		71032-16			Pkg. of 16		
		71032-50			Pkg. of 50		
		71032-100			Pkg. of 100		

### Seal Style 7 - H.D. OEM Style Solid Teflon w/ a Metal Jacket

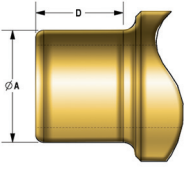
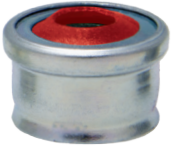
Stem Diameter	O.L.	Seal O.D.	Designed for these guide specs				OEM REF.
5/16"	0.375"	0.630"	A	B	C	D	1804698
			0.530"±0.002"	---	---	0.295"	
		Part Number			Quantity		
		71033-4			Pkg. of 4		
		71033-8			Pkg. of 8		
		71033-16			Pkg. of 16		
		71033-50			Pkg. of 50		
		71033-100			Pkg. of 100		

## Seal Style 7 - H.D. OEM Style Solid Teflon w/ a Metal Jacket

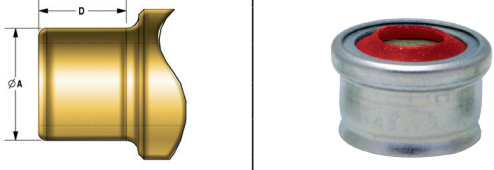
Stem Diameter	O.L.	Seal O.D.	Designed for these guide specs				OEM REF.
<b>11/32"</b>	0.375"	0.630"	A	B	C	D	---
			0.530"±0.002"	---	---	0.295"	
		<b>Part Number</b>			<b>Quantity</b>		
		<b>71034-4</b>			Pkg. of 4		
		<b>71034-8</b>			Pkg. of 8		
		<b>71034-16</b>			Pkg. of 16		
		<b>71034-50</b>			Pkg. of 50		
		<b>71034-100</b>			Pkg. of 100		

## Seal Style 7 - H.D. OEM Style Solid Teflon w/ a Metal Jacket

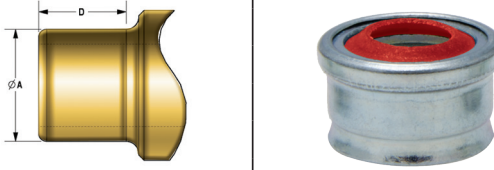
Stem Diameter	O.L.	Seal O.D.	Designed for these guide specs				OEM REF.
<b>3/8"</b>	0.375"	0.660"	A	B	C	D	---
			0.562"±0.002"	---	---	0.315"	
		<b>Part Number</b>			<b>Quantity</b>		
		<b>71035-4</b>			Pkg. of 4		
		<b>71035-8</b>			Pkg. of 8		
		<b>71035-16</b>			Pkg. of 16		
		<b>71035-50</b>			Pkg. of 50		
		<b>71035-100</b>			Pkg. of 100		

## Seal Style 7 - H.D. OEM Style Solid Teflon w/ a Metal Jacket

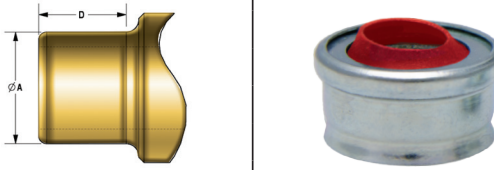
Stem Diameter	O.L.	Seal O.D.	Designed for these guide specs				OEM REF.
<b>3/8"</b>	0.400"	0.720"	A	B	C	D	1800081
			0.625"±0.002"	---	---	0.310"	
		<b>Part Number</b>			<b>Quantity</b>		
		<b>71036-4</b>			Pkg. of 4		
		<b>71036-8</b>			Pkg. of 8		
		<b>71036-16</b>			Pkg. of 16		
		<b>71036-50</b>			Pkg. of 50		
		<b>71036-100</b>			Pkg. of 100		

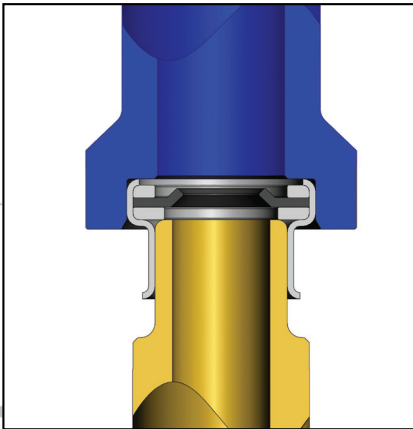

**Seal Installation Detail**





**Seal Installation Tool P/N 20-20835**

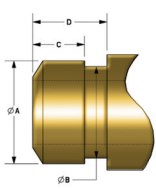

The Installation tools for OE style seals are manufactured from high strength 6061-T6 Aluminum for increased durability when compared to plastic installers. The tools are designed for precision fitment onto the seal OD to help the builder center the seal over the valve guide so that a few light strikes from a hammer will set the seal. Radiused top striking surface reduces the likelihood of a burr forming from deformation.

Each installation tool is color coded and laser marked for each seal size by guide diameter. For more information visit [KPML.US](http://KPML.US)

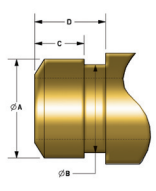

### BSA® B25™ 1968-1971 (2-Valve) Seal Kit

IN / Ex Stem Diameter			O.L	Seal O.D.	Designed for these guide specs			
					A	B	C	D
5/16"			0.465"	0.550"	0.500"±0.010"	0.445"	0.230"	0.280"
<b>Part Number</b>		Kit includes : 2- Intake / Exhaust Seals (Style 1)						
71012-2								

### BSA® Rocket III™ 1969-1972 (6-Valve) Seal Kit

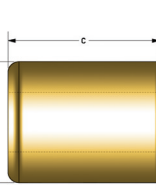

IN / Ex Stem Diameter			O.L	Seal O.D.	Designed for these guide specs			
					A	B	C	D
5/16"			0.465"	0.550"	0.500"±0.010"	0.445"	0.230"	0.280"
<b>Part Number</b>		Kit includes : 6- Intake / Exhaust Seals (Style 1)						
71012-6								

### Can Am® Maverick X3™ (Max / Turbo's) 2017-'18 / Maverick™ (Max / Turbo's) 2019-'20 Spark™ (ACE / 900 / HO / TRIXX) 2014-'19 / GTI-GTR-GTS™ 2017 / GTI™ 90 2018-'19 / GTS™ 90 2018(12-Valve) Seal Kit

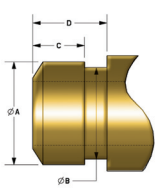

IN / Ex Stem Diameter			O.L	Seal O.D.	Designed for these guide specs			Spring Shoulder Dia.
					A	B	C	
5.0mm			0.460"	0.975"	0.355 ± 0.005	---	0.290"	0.674"
<b>Part Number</b>		Kit includes : 12- Intake / Exhaust Seals (Style 3)						
71047-12								

**NEW PRODUCTS**

### Honda® CRF™ / XR™ 75-100 1973-2013 (2-Valve) Seal Kit

IN / Ex Stem Diameter			O.L	Seal O.D.	Designed for these guide specs			
					A	B	C	D
5.5mm			0.320"	0.440"	0.358"±0.005"	0.320"	0.115"	0.225"
<b>Part Number</b>		Kit includes : 2- Intake / Exhaust Seals (Style 4)						
71016-2								

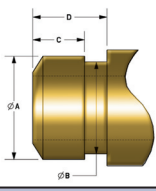
### Honda® ATC™ 185 / 200 1980-1986 • XL™ 200R/ XR™ 200 / XR™ 200R 1980-2002 XR™ 200R / XR™ 250R / XL™ 250R RFVC 1984-1985 (2-Valve) Seal Kit

IN / Ex Stem Diameter			O.L	Seal O.D.	Designed for these guide specs			
					A	B	C	D
5.5mm			0.320"	0.440"	0.358"±0.005"	0.320"	0.115"	0.225"
<b>Part Number</b>		Kit includes : 2- Intake / Exhaust Seals (Style 4)						
71016-2								

## Honda® CRF™ 450R 2002-2008 (4-Valve) Seal Kit

Intake Stem Diameter			O.L	Seal O.D.	Designed for these guide specs			
					A	B	C	D
5.5mm			0.320"	0.440"	0.358"±0.005"	0.320"	0.115"	0.225"
Exhaust Stem Diameter			O.L	Seal O.D.	Designed for these guide specs			
					A	B	C	D
5.0mm			0.350"	0.405"	0.340"±0.005"	0.303"	0.125"	0.230"
<b>Part Number</b>		Kit includes : 2 - Intake Seals (Style 4) and 2 - Exhaust Seals (Style 4)						
30-30550								

## Honda® CRF™ 450X 2005-2017 (4-Valve) Seal Kit

Intake Stem Diameter			O.L	Seal O.D.	Designed for these guide specs			
					A	B	C	D
5.5mm			0.320"	0.440"	0.358"±0.005"	0.320"	0.115"	0.225"
Exhaust Stem Diameter			O.L	Seal O.D.	Designed for these guide specs			
					A	B	C	D
5.0mm			0.350"	0.405"	0.340"±0.005"	0.303"	0.125"	0.230"
<b>Part Number</b>		Kit includes : 2 - Intake Seals (Style 4) and 2 - Exhaust Seals (Style 4)						
30-31570								



## Honda® TRX™ 450R / ER 2006-2014 (4-Valve) Seal Kit

Intake Stem Diameter			O.L	Seal O.D.	Designed for these guide specs			
					A	B	C	D
5.5mm			0.320"	0.440"	0.358"±0.005"	0.320"	0.115"	0.225"
Exhaust Stem Diameter			O.L	Seal O.D.	Designed for these guide specs			
					A	B	C	D
5.0mm			0.350"	0.405"	0.340"±0.005"	0.303"	0.125"	0.230"
<b>Part Number</b>		Kit includes : 2 - Intake Seals (Style 4) and 2 - Exhaust Seals (Style 4)						
30-30980								



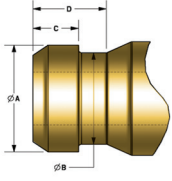

## KTM® XC4 Engines 400-530cc 2008-2013 (4-Valve) Seal Kit

Intake Stem Diameter			O.L	Seal O.D.	Designed for these guide specs			
					A	B	C	D
6.0mm			0.315"	0.520"	0.435"±0.002"	0.395"	0.120"	0.215"
Exhaust Stem Diameter			O.L	Seal O.D.	Designed for these guide specs			
					A	B	C	D
5.0mm			0.320"	0.435"	0.305"±0.002"	0.265"	0.100"	0.195"
<b>Part Number</b>		Kit includes : 2 - Intake Seals (Style 5) and 2 - Exhaust Seals (Style 5)						
96-96380								

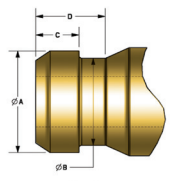

## Yamaha® Raptor™ 250 2008-2013 (2-Valve) Seal Kit

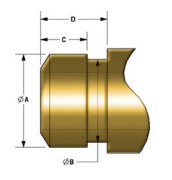
IN / Ex Stem Diameter			O.L	Seal O.D.	Designed for these guide specs			
					A	B	C	D
<b>6.0mm</b>			0.371"	0.480"	0.385"±0.002"	0.341"	0.120"	0.255"
<b>Part Number</b>		Kit includes : 2- Intake / Exhaust Seals (Style 5)						
<b>71017-2</b>								



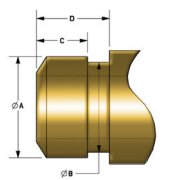

## Yamaha® WR™ / YZ 250F™ 2001-2013 (5-Valve) Seal Kit

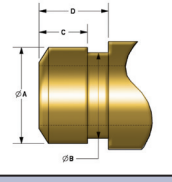
Intake Stem Diameter			O.L	Seal O.D.	Designed for these guide specs			
					A	B	C	D
<b>4.0mm</b>			0.320"	0.355"	0.285"±0.002"	0.245"	0.120"	0.215"
Exhaust Stem Diameter			O.L	Seal O.D.	Designed for these guide specs			
					A	B	C	D
<b>4.5mm</b>			0.331"	0.370"	0.321"±0.002"	0.281"	0.120"	0.240"
<b>Part Number</b>		Kit includes : 3 - Intake Seals (Style 5) and 2 - Exhaust Seals (Style 4)						
<b>80-80440</b>								

## Yamaha® YZ™ 250F 2014-'18 / WR™ 250F & YZ™ 250FX 2014-'19 (4-Valve) Seal Kit

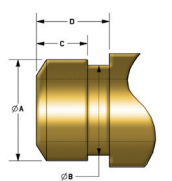

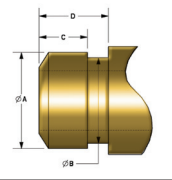
Intake Stem Diameter			O.L	Seal O.D.	Designed for these guide specs			
					A	B	C	D
<b>5.0mm</b>			0.350"	0.405"	0.340"±0.005"	0.303"	0.125"	0.230"
Exhaust Stem Diameter			O.L	Seal O.D.	Designed for these guide specs			
					A	B	C	D
<b>4.5mm</b>			0.331"	0.370"	0.321"±0.002"	0.281"	0.120"	0.240"
<b>Part Number</b>		Kit includes : 2 - Intake Seals (Style 4) and 2 - Exhaust Seals (Style 4)						
<b>80-80990</b>								

## YAMAHA® YZ™ 250F 2019-2020 (4-Valve) Seal Kit

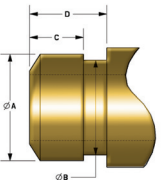

Intake Stem Diameter			O.L	Seal O.D.	Designed for these guide specs			
					A	B	C	D
<b>5.0mm</b>			0.350"	0.405"	0.340"±0.005"	0.303"	0.125"	0.230"
Exhaust Stem Diameter			O.L	Seal O.D.	Designed for these guide specs			
					A	B	C	D
<b>4.5mm</b>			0.331"	0.370"	0.321"±0.002"	0.281"	0.120"	0.240"
<b>Part Number</b>		Kit includes : 2 - Intake Seals (Style 4) and 2 - Exhaust Seals (Style 4)						
<b>80-82345</b>								

**NEW PRODUCTS**

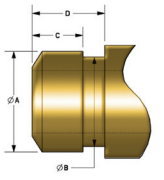

## Yamaha® WR™ / YZ™ 400F / 426F 1998-2002 (5-Valve) Seal Kit

IN / Ex Stem Diameter			O.L	Seal O.D.	Designed for these guide specs			
					A	B	C	D
<b>4.5mm</b>			0.331"	0.370"	0.321"±0.002"	0.281"	0.120"	0.240"
<b>Part Number</b> <b>80-80106</b>		Kit includes : 5 - Intake / Exhaust Seals (Style 4)						

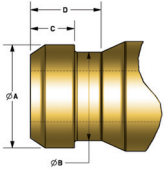

## Yamaha® Various 450cc 2003-2020 (5-Valve) Seal Kit

IN / Ex Stem Diameter			O.L	Seal O.D.	Designed for these guide specs			
					A	B	C	D
<b>4.5mm / 5.0mm</b>			0.331"	0.370"	0.321"±0.002"	0.281"	0.120"	0.240"
<b>Part Number</b> <b>80-80710</b>		Kit includes : 5 - Intake / Exhaust Seals (Style 4)						

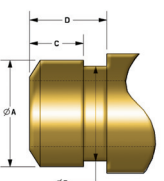

## Yamaha® Various 660's 2001-2008 (5-Valve) Seal Kit

IN / Ex Stem Diameter			O.L	Seal O.D.	Designed for these guide specs			
					A	B	C	D
<b>6.0mm</b>			0.371"	0.480"	0.385"±0.002"	0.341"	0.120"	0.255"
<b>Part Number</b> <b>71017-5</b>		Kit includes : 5- Intake / Exhaust Seals (Style 5)						

## Yamaha® APEX™ / RX-1 (All Models) 2003-2010 MR-1 Watercraft Engines 2002-2013 (20-Valve) Seal Kit

IN / Ex Stem Diameter			O.L	Seal O.D.	Designed for these guide specs			
					A	B	C	D
<b>4.5mm</b>			0.331"	0.370"	0.321"±0.002"	0.281"	0.120"	0.240"
<b>Part Number</b> <b>71014-20</b>		Kit includes : 20- Intake / Exhaust Seals (Style 4)						

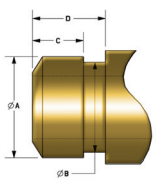
## Arctic Cat® Various 998cc Triples 2017-2019 Yamaha® SRViper™ 2014-2015 / Various 1049cc Triples 2008-2015 YZ™ 1000R 2016-2020/ FX Nytro™ 2008-2014 (12-Valve) Seal Kit

IN / Ex Stem Diameter			O.L	Seal O.D.	Designed for these guide specs			
					A	B	C	D
<b>4.5mm</b>			0.331"	0.370"	0.321"±0.002"	0.281"	0.120"	0.240"
<b>Part Number</b> <b>71014-12</b>		Kit includes : 12- Intake / Exhaust Seals (Style 4)						



# KPMI® Seal Part Numbers Assigned to Applications

If specific application is not listed, use the diagram and specifications to determine correct valve guide seal part number.

KPMI P/N	APPLICATIONS
71014-12	ARCTIC CAT® VARIOUS 998cc TWINS 2017-'19
71016-8	ARCTIC CAT® VARIOUS 1056cc TWINS 2008-'16
71029-4	BRP® • CAN AM® DS 450™ 2008-2015
71041-4	BRP® • CAN AM® OUTLANDER 300/ 400cc 2004-'15 (4 Valve)
71041-8	BRP® • CAN AM® VARIOUS 500 -1000cc Twins 2006-'20
71025-4	<b>NEW PRODUCTS</b> BRP® • CAN AM® DS™ 650 2000-2007
71042-8	BRP® • CAN AM® MAVERICK™ 2013-2018
71019-4	BRP® • ROTAX® AIR COOLED SINGLES 500/600 1982-'06
71012-2	BSA® B25™ 1968-1971
71012-6	BSA® ROCKET III™ 1968-1973
71043-4	Ducati® 750 GT™ 1971-1974
71043-4	Ducati® 750/ 906 1986-1990
71044-4	Ducati® SBK™ 851/ 888/ 916 1987-1998
71043-4	Ducati® 900/ 800 2000-2007
71044-4	Ducati® Various 696/ 796/ 1000/ 1100 2003-2010
71011-4	HD® PANHEAD™ 1948-1965
71002-4	HD® PANHEAD™ 1948-1965
71035-4	HD® PANHEAD™ 1948-1965
71035-50	HD® PANHEAD™ 1948-1965
71035-100	HD® PANHEAD™ 1948-1965
71033-4	HD® SPORTSTER™ 1957-1969
71033-50	HD® SPORTSTER™ 1957-1969
71033-100	HD® SPORTSTER™ 1957-1969
71034-4	HD® SPORTSTER™ 1957-1969
71034-50	HD® SPORTSTER™ 1957-1969
71034-100	HD® SPORTSTER™ 1957-1969
71033-4	HD® SPORTSTER™ 1970-1983
71033-50	HD® SPORTSTER™ 1970-1983
71033-100	HD® SPORTSTER™ 1970-1983
71034-4	HD® SPORTSTER™ 1970-1983
71034-50	HD® SPORTSTER™ 1970-1983
71034-100	HD® SPORTSTER™ 1970-1983
71035-4	HD® SHOVELHEAD™ 74" 1966-1977
71035-50	HD® SHOVELHEAD™ 74" 1966-1977
71035-100	HD® SHOVELHEAD™ 74" 1966-1977
71011-4	HD® SHOVELHEAD™ 74" 1966-1977

KPMI P/N	APPLICATIONS
71002-4	HD® SHOVELHEAD™ 74" 1966-1977
71036-4	HD® SHOVELHEAD™ 80" 1978-1983
71036-50	HD® SHOVELHEAD™ 80" 1978-1983
71036-100	HD® SHOVELHEAD™ 80" 1978-1983
71011-4	HD® SHOVELHEAD™ 80" 1978-1983
71002-4	HD® SHOVELHEAD™ 80" 1978-1983
71010-4	HD® EVOLUTION™ 1984-1999
71008-4	HD® EVOLUTION™ 1984-1999
71032-4	HD® EVOLUTION™ 1984-1999
71032-50	HD® EVOLUTION™ 1984-1999
71032-100	HD® EVOLUTION™ 1984-1999
71032-4	HD® EVO SPORTSTER™ 883cc 1986-'03
71032-50	HD® EVO SPORTSTER™ 883cc 1986-'03
71032-100	HD® EVO SPORTSTER™ 883cc 1986-'03
71010-4	HD® EVO SPORTSTER™ 883cc 1986-'03
71008-4	HD® EVO SPORTSTER™ 883cc 1986-'03
71030-4	HD® EVO SPORTSTER™ 883cc 2004-'20
71030-50	HD® EVO SPORTSTER™ 883cc 2004-'20
71030-100	HD® EVO SPORTSTER™ 883cc 2004-'20
71028-4	HD® EVO SPORTSTER™ 883cc 2004-'20
71032-4	HD® XL™ 1100cc 1986-1987
71032-50	HD® XL™ 1100cc 1986-1987
71032-100	HD® XL™ 1100cc 1986-1987
71010-4	HD® XL™ 1100cc 1986-1987
71008-4	HD® XL™ 1100cc 1986-1987
71032-4	HD® EVO SPORTSTER™ 1200cc 1988-'03
71032-50	HD® EVO SPORTSTER™ 1200cc 1988-'03
71032-100	HD® EVO SPORTSTER™ 1200cc 1988-'03
71010-4	HD® EVO SPORTSTER™ 1200cc 1988-'03
71008-4	HD® EVO SPORTSTER™ 1200cc 1988-'03
71030-4	HD® EVO SPORTSTER™ 1200cc 2004-'20
71030-50	HD® EVO SPORTSTER™ 1200cc 2004-'20
71030-100	HD® EVO SPORTSTER™ 1200cc 2004-'20
71028-4	HD® EVO SPORTSTER™ 1200cc 2004-'20
71032-4	HD® TWIN CAM™ 88" 1999-2004

# KPMI® Seal Part Numbers Assigned to Applications

If specific application is not listed, use the diagram and specifications to determine correct valve guide seal part number.

KPMI P/N	APPLICATIONS
71032-50	HD® TWIN CAM™ 88" 1999-2004
71032-100	HD® TWIN CAM™ 88" 1999-2004
71010-4	HD® TWIN CAM™ 88" 1999-2004
71008-4	HD® TWIN CAM™ 88" 1999-2004
71030-4	HD® TWIN CAM™ 88"-103" 2005-2017
71028-4	HD® TWIN CAM™ 88"-103" 2005-2017
71030-4	HD® BUELL® XB9™ 2003-2007
71028-4	HD® BUELL® XB9™ 2003-2007
71046-8	<b>NEW PRODUCTS</b> HD® Milwaukee-Eight 2017-2020
71016-2	HONDA® CRF™ / XR™ 75-100 1985-2013
71014-4	HONDA® CRF™ 150R 2007-2021
71016-4	<b>NEW PRODUCTS</b> HONDA® CB™ 160 1965-1969
71016-4	HONDA® CB™ 175 1970-1975
71016-2	HONDA® ATC™ 185 / 200 1980-1986
71016-2	HONDA® XL™ 200R / XR™ 200 / XR™ 200R 1980-02
71016-4	HONDA® XR™ 200R 1984-1985 RFVC
71014-4	HONDA® CRF™ 250R 2004-'07 / 250X 2004-'17
71014-4	HONDA® CRF™ 250R 2008-2009
71014-4	HONDA® CRF™ 250R 2010-2017
71014-4	<b>NEW PRODUCTS</b> HONDA® Various 250-300's 2011-2021
71016-4	HONDA® TRX™ 250X 1987-1992
71016-2	HONDA® XR™ / XL™ 250R RFVC 1984-'95
71016-4	HONDA® XR™ 250R RFVC 1996-2004
71016-4	HONDA® XR™ 350 RFVC 1983-1985
71016-4	HONDA® XR™ 250L 1991-1996
71016-4	HONDA® TRX™ 300EX / X 1993-2009
71015-4	HONDA® CB™ / CL™ 350 TWIN 1968-'73 (5mm Conv.)
71040-8	<b>NEW PRODUCTS</b> HONDA® CB™ 350F / 400F 1972-1977
71016-4	HONDA® TRX™ 400X/ 400EX 1999-'14
71016-4	HONDA® XR™ 400 RFVC 1996-2004
71015-4	HONDA® CB™ 450 1965-'72 / CB™ 500 TWIN 1965-'76 (5mm Conv.)
30-30550	HONDA® CRF™ 450R 2002-2008
71015-4	HONDA® CRF™ 450R 2009-2012
71015-4	HONDA® CRF™ 450R 2013-2016
30-31570	HONDA® CRF™ 450X 2005-2017
71015-4	<b>NEW PRODUCTS</b> HONDA® CRF™ 450R / RX/ WE 2017-2021
71016-4	HONDA® TRX™ 450R 2004-2005

KPMI P/N	APPLICATIONS
30-30980	HONDA® TRX™ 450R / ER 2006-2014
71016-8	HONDA® CB™ 500 / 4 - CB™ 550 / 4 1971-'78
71013-16	HONDA® CBR™ 600 F2 / F3 1991-1996
71013-16	HONDA® CBR™ 600F4i 2001-2006
71018-4	HONDA® VARIOUS 500cc-650cc 1983-'18
71018-4	HONDA® XR™ 650R 2000-2007
71018-4	HONDA® TRX™ 700XX 2008-2009
71018-8	HONDA® CB™ / 750 SOHC 1969-1977
71015-8	HONDA® CB™ 750 SOHC 1969-1977 (5mm Conv.)
71016-16	HONDA® CB™ 750 DOHC 1979-1983
71014-16	HONDA® CBR™ 900RR 1993-1999
71016-8	<b>NEW PRODUCTS</b> HONDA® CRF™ 1000A/D 2017-2019
71016-8	<b>NEW PRODUCTS</b> HONDA® Pioneer™ 1000 2016-2021
71016-8	<b>NEW PRODUCTS</b> HONDA® Talon™ 1000X/R 2019-2021
71016-16	HONDA® VARIOUS 750cc-1100cc 1979-'83
71016-24	HONDA® CBX 6 CYLINDER 1979-1982
71029-4	<b>NEW PRODUCTS</b> HUSQVARNA® VARIOUS 510-610cc 1983-2001
71016-8	<b>NEW PRODUCTS</b> INDIAN® Scout™ 4V 1200's 2015-2019
71048-8	<b>NEW PRODUCTS</b> INDIAN® Scout™ 4V 1200's 2015-2019
71013-4	KAWASAKI® KX250F™ 2004-2016
71013-4	<b>NEW PRODUCTS</b> KAWASAKI® KX250F™ 2017-2019
71013-4	KAWASAKI® KLX™ 300R/ 250R/ S/ SF 1994-'14
71015-4	KAWASAKI® KLX™/ KFX™ 400 2001-'06
71016-4	KAWASAKI® KLX 450R™ 2008-2020
71016-4	KAWASAKI® KX 450F™ 2006-2008
71016-4	KAWASAKI® KX 450F™ 2009-2016
71016-4	KAWASAKI® KFX 450R™ 2008-2014
71016-8	KAWASAKI® NINJA 500R™ 1987-2009
71013-8	<b>NEW PRODUCTS</b> KAWASAKI® NINJA™ 650R / VERSYS 2006-'16
71015-8	KAWASAKI® VARIOUS 650/ 700/ 750 2005-2013
71014-8	KAWASAKI® VARIOUS 650/ 750/ 800 2012-2020
71019-8	KAWASAKI® KZ™ / Z1™ 900 1973-1977
71019-8	KAWASAKI® KZ™ / Z1™ POLICE 1000 1977-'05
71016-8	KAWASAKI® NINJA™ 1000R 1986-1987
71019-8	KAWASAKI® GPZ™ 1100 1981-1982
71013-16	KAWASAKI® ZX-7R™ 1991-1995
71013-16	KAWASAKI® ZX-7R™ 1996-2003
71013-16	KAWASAKI® ZX-9R™ 1994-2003

KPMI P/N	APPLICATIONS
71015-16	<b>NEW PRODUCTS</b> KAWASAKI® ZX-10R™ 1988-1990
71013-16	KAWASAKI® ZX-10R™ 2011-2013
71015-16	KAWASAKI® ZX-11™ / ZRX™ 1100 / 1200 1999-'05
71015-16	KAWASAKI® ZX-12R™ 2000-2005
71015-16	KAWASAKI® ZX-14™ 2006-2011
71015-16	<b>NEW PRODUCTS</b> KAWASAKI® PWC™ 2007-2019
71029-4	KTM® ALL RFS ENGINES 400cc-560cc 2000-'09
71041-4	KTM® 250 2005-2007 (For RC4 Engines)
71041-4	KTM® 250 2008-2011 (For RC4 Engines)
71041-4	KTM® 250 2012-2013 (For RC4 Engines)
71041-4	KTM® SX-F / XC-F 250 2013-2015
71029-4	KTM® 450 2007-2011 (For RC4 Engines)
96-96380	KTM® 400-530cc 2008-2013 (XC4 Engines)
71029-4	<b>NEW PRODUCTS</b> KTM® VARIOUS 450'S 2013-2018
71012-4	NORTON® 750 1968-1973
71012-4	NORTON® 850 1973-1977
71017-4	POLARIS® PREDATOR™ / OUTLAW™ 500 2003-'07
71017-4	POLARIS® SPORTSMAN™ 800 2006-2014
71017-4	POLARIS® RZR™ 800 2008-2010
71017-4	POLARIS® RZR™ 800 (&S/4) / RANGER 800 2011-'17
71015-8	POLARIS® RZR™ XP900 2011-2012
71048-8	<b>NEW PRODUCTS</b> POLARIS® RZR™ XP900 2011-2012
71015-8	POLARIS® RZR™ XP900 2013-2014
71048-8	<b>NEW PRODUCTS</b> POLARIS® RZR™ XP900 2013-2014
71016-8	POLARIS® Ranger™ 900 XP 2013-'15 / RZR™ 900 2015-'16
71048-8	<b>NEW PRODUCTS</b> POLARIS® Ranger™ 900 XP 2013-'15 / RZR™ 900 2015-'16
71016-8	POLARIS® RZR™ XP1000 2014
71048-8	<b>NEW PRODUCTS</b> POLARIS® RZR™ XP1000 2014
71048-8	<b>NEW PRODUCTS</b> POLARIS® RZR™ XP1000 2015-'20 / XP Turbo 2016-'20
71015-4	SUZUKI® DR™ 250 / 350S / SE 1990-'99
71013-4	SUZUKI® RM-Z250™ 2004-2006
71013-4	SUZUKI® RM-Z250™ 2007-2017
71015-4	SUZUKI® DR-Z400™ E / S / SM / LT-Z400™ / 400Z™ 2000-'19
71016-4	SUZUKI® LTR™ 450 / 450Z 2006-2009
71015-4	SUZUKI® RM-Z450™ 2005-2006
71016-4	SUZUKI® RM-Z450™ 2007
71016-4	SUZUKI® RM-Z450™ 2008-2020
71014-16	SUZUKI® GSX-R™ 600 1997-2000
71014-8	SUZUKI® SV™ 650 1999-2009
71016-4	<b>NEW PRODUCTS</b> SUZUKI® KING QUAD's 700-750 2005-'20
71019-4	SUZUKI® DR™ 750 / 800 BIG 1988-1998

KPMI P/N	APPLICATIONS
71019-8	SUZUKI® GS™ 750 PRE-1980
71016-16	SUZUKI® GS™ 750 E / ES / L / T 1980-1986
71015-16	SUZUKI® GS™ 750 E / ES / L / T 1980-1986 (5mm Conv.)
71015-16	SUZUKI® GSX-R™ 750 1980-1992
71014-16	SUZUKI® GSX-R™ 750 1993-1995
71014-16	SUZUKI® GSX-R™ 750 SRAD 1996-1999
71018-8	SUZUKI® GS™ 1000 PRE-1981
71014-16	SUZUKI® GSX-R™ 1000 2005-2008
71016-16	SUZUKI® GS™ 1100 E / ES / S 1980-1986
71015-16	SUZUKI® GSX-R™ 1100 1986-1990
71015-16	SUZUKI® GSX-R™ 1100 1991-1992
71014-16	SUZUKI® GSX-R™ 1100 1993-1998
71016-16	SUZUKI® GS™ 1150 1984-1986
71015-16	SUZUKI® GS™ 1150 1984-1986 (5mm Conv.)
71015-16	<b>NEW PRODUCTS</b> SUZUKI® HAYABUSA™ 1999-2019
71017-4	TRIUMPH® 650 / 750 1963-1983 (6mm Conv.)
71012-4	TRIUMPH® 650 / 750 1963-1983
71012-4	TRIUMPH® Pre-Unit 500 / 600 1951-'62 / TRIDENT™ 1971-76
71016-8	TRIUMPH® 865 2001-2010
71017-2	YAMAHA® RAPTOR™ 250 2008-2013
71016-4	YAMAHA® SRX™ 250 / XT™ 250 / 350 1984-2000
80-80440	YAMAHA® WR™ / YZ™ 250F 2001-2013
80-80990	YAMAHA® YZ™ 250F 2014-'18 / WR™ 250F & YZ™ 250FX 2014-'19
80-82345	<b>NEW PRODUCTS</b> YAMAHA® YZ™ 250F 2019-2020
80-80106	YAMAHA® WR™ / YZ™ 400F/426F 1998-'02
80-80710	YAMAHA® VARIOUS 450cc 2003-2020
71040-4	YAMAHA® YZ™ 450F 2010-2013
71040-4	YAMAHA® YZ™ 450F 2014-2019 / 450FX 2016-2020
71017-5	YAMAHA® VARIOUS 660'S 2001-2008
71017-4	YAMAHA® VARIOUS 700'S 2006-2020
71014-12	<b>NEW PRODUCTS</b> YAMAHA® YXZ 1000R 2016-2020
71016-16	YAMAHA® FJ™ 1100 / 1200 1984-1993
71016-16	YAMAHA® V-MAX™ 1985-2007
71014-20	YAMAHA® YZF™ R1 1998-2003
71014-12	YAMAHA® Various 1049cc Triples 2008-2015
71014-8	YAMAHA® APEX™ / RX-1 (ALL MODELS) 2003-2010
71014-8	<b>NEW PRODUCTS</b> YAMAHA® MR-1™ Watercraft eng. 2002-'13
71040-16	<b>NEW PRODUCTS</b> YAMAHA® 1.8L 4V Watercraft 2008-2019

For the full range and to check availability for your parts visit [www.kpmi.us](http://www.kpmi.us)



**KIBBLEWHITE PRECISION MACHINING INC.**

**MADE IN USA**

**ENGINEERING VALVETRAIN FOR 80 - YEARS & 2 - GENERATIONS**

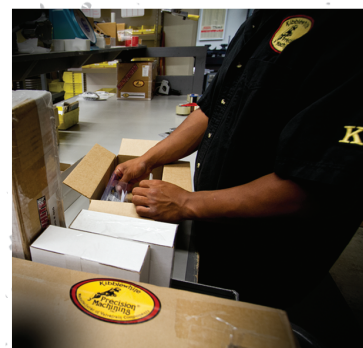
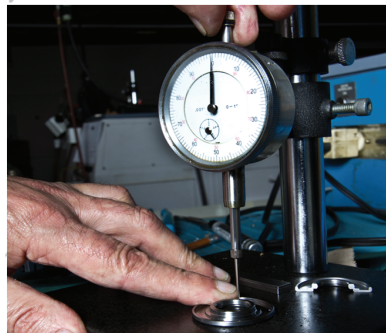
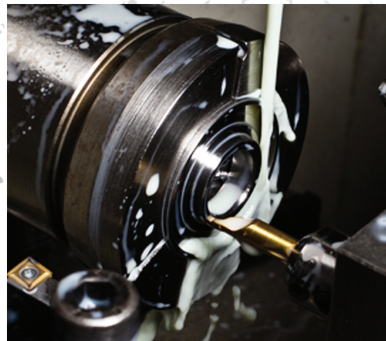

Find your parts and order online at [www.kpmi.us](http://www.kpmi.us) or contact your local dealers and distributors today!

**KIBBLEWHITE PRECISION MACHINING, INC**  
**580-H CRESPI DRIVE - PACIFICA, CA 94044**

**WWW.KPMI.US - FACEBOOK.COM/KPMUSA**

**SALES@KPMI.US**