

184 Davenport

TORONTO, ONTARIO

SPACE AVAILABLE:

673 SF

RATE: \$3000.00 Net

TMI: \$965.94

FEATURES:

- Beautiful main floor space in high-end boutique building on Davenport.
- Easy access to all the amenities of Yorkville.
- Great layout, perfect for boutique retail, gallery/ studio space, or professional office with plenty of natural light.
- Open concept layout with private washroom and direct access to a tandem parking space (\$150/mth)



REGENT STREET

Retail & Restaurant Real Estate Solutions

CONTACT:

ANDREA BULLER*

VICE PRESIDENT

ANDREA.BULLER@REGENTSTRET.CA

All information is from sources deemed reliable and is submitted subject to errors, omissions, change of price, rental, prior sale and withdrawal without notice.

*Salesperson

184 Davenport
TORONTO, ONTARIO

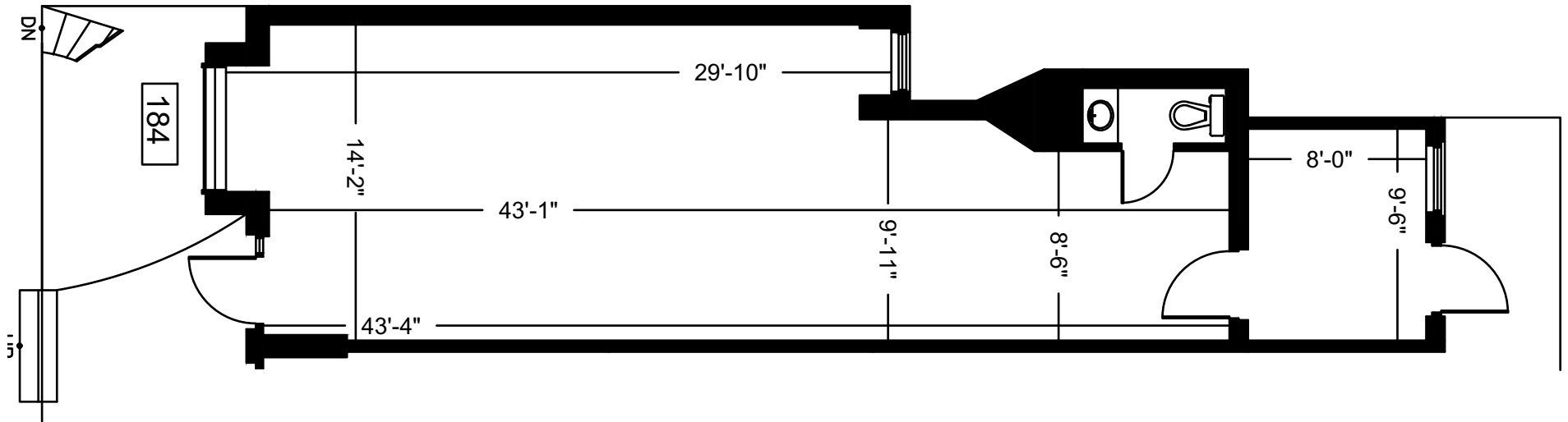

REGENT STREET
Retail & Restaurant Real Estate Solutions

CONTACT:

ANDREA BULLER*

VICE PRESIDENT

ANDREA.BULLER@REGENTSTRET.CA

All information is from sources deemed reliable and is submitted subject to errors, omissions, change of price, rental, prior sale and withdrawal without notice.