

3/4" PLYWOOD
BLOCKING
(BY OTHERS)

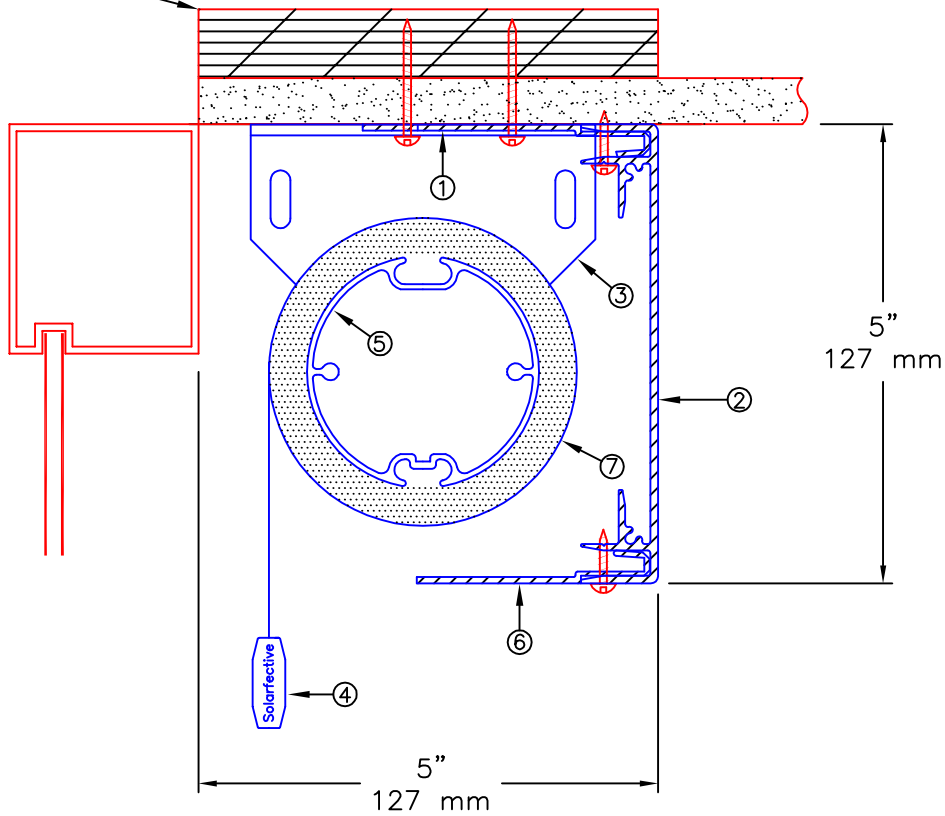

NOTES:

1. MOUNTING ANGLE
2. EXTRUDED ALUMINUM 5" FASCIA
3. END BRACKETS
4. EXTRUDED ALUMINUM EXTERIOR HEMBAR
5. 2" Ø EXTRUDED ALUMINUM TUBE
6. 2 5/8" EXTRUDED ALUMINUM CLOSURE
7. FABRIC: 1%, 3%, 5%, 10% OPENNESS OR BLACKOUT

**** NOTE ****

JUNCTION BOX TO BE LOCATED WITHIN 3 FT OF MOTOR LOCATION. MOTOR LOCATION TO BE DETERMINED WITH SOLARFACTIVE REPRESENTATIVE.

Solarfactive

55 Hymus Road, Scarborough
Ontario, Canada. M1L 2C6

Tel. (416) 421-3800
Fax. (416) 421-8424

Web Site: www.solarfactive.com
Email: shades@solarfactive.com

MOTORIZED SHADE
WITH CEILING MOUNT 5" FASCIA

PROJECT: -

DATE:
JAN. 01, 2015

SCALE:
N.T.S.

FILE No.
-

DRAWN:
ADIE

DWG. No.
ES-12

REV
0