



**VME / cPCI CHASSIS & ENCLOSURES, BACKPLANES, 19" SUB RACKS, CARD GUIDES, CUSTOM BACKPLANES, EXTENDERS AND ACCESSORIES**

11115 Vanowen Street, North Hollywood, CA 91605

[www.Vectorelect.com](http://www.Vectorelect.com) 1-800-423-5659 [Inquire@Vectorelect.com](mailto:Inquire@Vectorelect.com)

## **4626-Series Single, Dual and Triple-slot Power Supply Backplanes**



## Contents

1. Reference Documentation	3
2. Description and Features	3
2.1 Description	3
2.2 Features	3
3. Power Input	4
4. Power Output	4
4.1 ATX Connector	5
4.2 Power screw terminals (power bugs)	6
4.3 PCI-47-Style 'P47' Power Supply Connectors	6
4.4 Control Header	9
4.5 Local / Remote Voltage Sensing	10
4.6 Geographic Address Option	11
5. Mechanical Drawings	
5.1 4626-11 Single-slot	12
5.2 4626-12 Dual-slot	13, 14
5.3 4626-14 Triple-slot	15, 16

CompactPCI® and PICMG® are registered trademarks of Cat.# 02127-002 S  
the PCI Industrial Computer Manufacturers Group.

## 1. Reference Documentation

PICMG 2.0 Rev. 3.0            CompactPCI Specification  
PICMG 2.11 Rev. 1.0        CompactPCI Power Interface Specification  
IEEE Std. 1101.10 – 1996  
PCI Hardware and Software Architecture & Design, Third Edition  
by Ed Solari    RTC Books Date published: 4/1/1996  
ISBN-13: 9780929392325; ISBN: 0929392329

## 2. Description and Features

### 2.1 Description

**4626-11** is a 1.544"W 3U X 8HP power supply backplane for **ONE** CompactPCI plug-in power supply (Assy P/N's **0900-0017-\*\***).

**4626-12** is a 3.144"W, 3U X 16HP power supply backplane for **TWO** CompactPCI plug-in power supplies (Assy P/N's **0900-0018-\*\***).

**4626-14** is a 4.744"W, 3U X 24HP power supply backplane for **THREE** CompactPCI plug-in power supplies (Assy P/N's **0900-0023-\*\***).

(Assy P/N's '\*\*' = '-01' fully populated, others '-' numbers can include many combinations of board loading, please contact factory or e-mail [Inquire@Vectorelect.com](mailto:Inquire@Vectorelect.com)).

### 2.2 Features

20-pin ATX power headers distributed across the power plane, one for each power supply

The distribution allows power to be sourced from either any the power supplies (4626-12, 4626-14). Power 'bugs' (screw terminals) are provided for high current output of each voltage. One 3-pin Mate-N-Lok power connector for AC or DC power input. Geographic addressing headers are provided for each power supply.

**Vector can customize the 4626 design to suit your specific need, please contact us at:**  
**[Inquire@Vectorelect.com](mailto:Inquire@Vectorelect.com)**

### 3.0 Power Input

#### 4626-series AC Power In (AMP Mate-N-Lok)

A single 1x3 style AMP Mate-N-Lok connector is provided for AC power input. Total current available from line to neutral is about 11 Amps (derated for a 30C-temperature rise with a minimum cable length of 11.3"). See the following pin-out for the Mate-N-Lok connector:

#### Mate-N-Lok Pin Assignments

Mate-N-Lok Pin Number	Name	Derated Current Capacity (30C temp. rise)	P47 Connector Connection
1	CHASSIS GROUND	11 Amps (16 AWG WIRE)	Connected to CGND, Pin 45
2	LINE	11 Amps (16 AWG WIRE)	Connected to ACL, Pin 47
3	NEUTRAL	11 Amps (16 AWG WIRE)	Connected to ACN, Pin 46

These terminals can be used to connect a DC input supply. -48VDC and -48VDC\_return are connected to AC Line and AC Neutral respectively. Refer to the power supply specifications for details.

### 4. Power Output

All series 4626 power backplanes have +5V, +3.3V, +12V, and -12V outputs.

#### 4.1 ATX Connectors

Power is provided from the backplane through the use of one 20-pin ATX style power connectors for each slot. See the following for a pinout of these connectors.

#### ATX Connector Pinout – Power Supply Backplane REAR

Description	Pin	Pin	Description
+3.3V	11	1	+3.3V or 3S+ (see note next page)
-12V	12	2	+3.3V
COM	13	3	COM
** PS_ON or INH#	14	4	+5V
COM	15	5	COM
** COM or 5S-	16	6	+5V
COM	17	7	COM
** -5V or 12S+	18	8	** PW_OK or FAL# (see note next page)
** +5V or 5S+	19	9	** 5VSB or DEG# (see note next page)
+5V	20	10	+12V

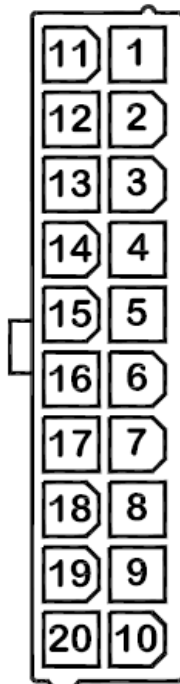

**NOTE:** These signals are not 'standard' ATX signals. INH#, DEG#, and FAL# are connected directly to the CompactPCI power supplies.

Please see the CompactPCI specification for a description of these signals. SEN3V, SEN5V, SEN12V, and SENGND are voltage sensing signals. Voltage sensing signals are standard and are present on every ATX connector. When a small difference in voltages are measured, the power supplie(s) will average the value. Connector positions are derated to 9A of current for a 20-position connector and a 30C-temperature rise. The following are the maximum currents that can be drawn through each ATX Connector:

Supply Voltage	Nominal Current (each ATX Connector)	Derated Current (each ATX Connector) (4626-11)	Derated Current for 2 ATX Connectors (4626-12)	Derated Current for 3 ATX Connectors (4626-14)
+5V	36 Amps	27 Amps	54 Amps	81 Amps
+3.3V	24 Amps	18 Amps	36 Amps	54 Amps
+12V	12 Amps	9 Amps	18 Amps	27 Amps
-12V	12 Amps	9 Amps	18 Amps *	27 Amps

#### 4.2 Screw Terminals (Power Bugs)

There are power output screw terminals (power bugs) that can be used when the current is greater than the capacity of the ATX connector.

The power bugs have #6 screws for typical ring or fork-type lugs. The power bugs are individually insulated, 40A rated, and derated to 25A at 30C. Terminal voltage and assignment and ratings table below:

4626-11 Voltage	4626-11 Location	No.Power Bugs	4626-11 Max Current	4626-12 Voltage	4626-12 Location	No.Power Bugs	4626-12 Max Current
+3.3	J6	1	40A	+3.3	J8, J9	2	80A
+5.0	J7	1	40A	+5.0	J17	1	40A
+12	J4	1	40A	+12	J10	1	40A
-12	J5	1	40A	-12	J11	1	40A
GND	J9	2	80A	GND	J3, J15, J16	3	120A

4626-14 Voltage	4626-14 Location	No.Power Bugs	4626-14 Max Current
+3.3	J8, J10, J14	3	120A
+5.0	J12, J16	2	80A
+12	J13, J18	2	80A
-12	J17, J19	2	80A
GND	J7, J9, J11, J15	4	160A

**IF LONGER SCREWS ARE USED, MAKE ABSOLUTELY SURE THAT THE TIP OF THE SCREW DOES NOT COME IN CONTACT WITH THE BOARD SURFACE OR SHORTING MAY OCCUR.**

#### 4.3 P47 Connector(s)

PCI47-type connectors will allow for the plug-in of 8HP wide PICMG 2.11 power supplies. The larger #16 contacts have a current rating of 28A each, derated to 16A for a 30Ctemperature rise. The smaller #22 contacts have a current rating of 3A each.

All power slots support power supplies compatible with PICMG 2.11 R1.0 Power

**Total Current Capacity of PCI47-style Connector**

Supply	Nominal Current per PCI47-style Connector	Derated Current per PCI47-style Connector (4626-11)	Derated Current for 2 PCI47-style Connectors (4626-12)	Derated Current for 3 PCI47-style Connectors (4626-14)
+5.0V	112 Amps	64 Amps	128 Amps *	192 Amps
+3.3V	168 Amps	80 Amps	160 Amps *	240 Amps
+12.0V	56 Amps	32 Amps	64 Amps *	96 Amps
-12.0V	3 Amps	1.5 Amps	3 Amps	4.5 Amps

*The ATX connectors will limit the total current capacity. All connectors use the pinouts as shown in PCI47-style connector Pinout & Mechanical Location*

**PCI47-style, 'P47' power connector pinout**

Description	Pin	Pin	Description
AC Line/-DC_IN	47	31	GA2
AC Neutral/DC_RTN	46	30	+5V Sense
Chassis GND	45	29	+5V Adjust
+12V Current Share	44	28	GA1
IPMB PWR	43	27	Enable
FAIL	42	26	RSVD
+3.3V Current Share	41	25	GA0
IPMB SDA	40	24	GND
Inhibit	39	23	RSVD
Degrade	38	22	RTN
IPMB SCL	37	21	-12V
+12V Sense	36	20	+12V
+5V Current Share	35	19	GND
GND Sense	34	13-18	+3.3V
+3.3V Sense	33	5-12	GND
3.3V Adjust	32	1-4	+5V

**PCI47-style, 'P47' POWER CONNECTOR FRONT VIEW**

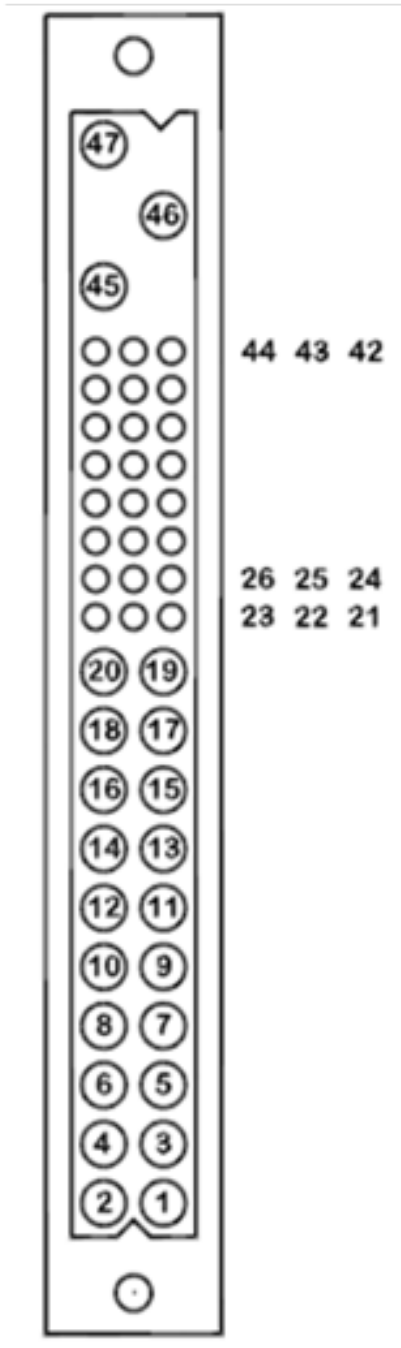

**PCI47-style, 'P47' Connector may be blue, grey or black**



#### 4.4 Utility Control Connector (Black or Blue 20-pin header)

A 20-pin header connector is installed at JP1 on series 4626 where the following signals can be accessed:

#### BLACK OR BLUE UTILITY (CONTROL) CONNECTOR PIN ASSIGNMENTS

Pin Number	Signal	Description
1	FAL#	Power supply failure. Connected to the power supply FAL# pin. (see PICMG 2.11, R 1.0, & PICMG 2.0, R3)
2	ISH12V	Connected to the power supply ISHARE12V pin. (not used for normal operation)
3	GND	Ground return for the power supply output rails.
4	ISH3V	Connected to the power supply ISHARE3V pin. (not used for normal operation)
5	INH#	Power supply inhibit. Connected to the power supply INH# pin. (see PICMG 2.11, R 1.0, & PICMG 2.0, R3)
6	ISH5V	Connected to the power supply ISHARE5V pin. (not used for normal operation)
7	SENGND	Voltage sense ground return line. Connected to the power supply SENGDND pin.
8	SEN12V	+12V sense line. Connected to the power supply SEN12V pin.
9	SENGND	Voltage sense ground return line. Connected to the power supply SENGDND pin.
10	SEN3V	+3.3V sense line. Connected to the power supply SEN3V pin.
11	SENGND	Voltage sense ground return line. Connected to the power supply SENGDND pin.
12	SEN5V	+5V sense line. Connected to the power supply SEN5V pin.
13	RESVD1	Reserved pin, uncommitted
14	DEG#	Power supply degrade signal. Connector to the power supply DEG# pin (see PICMG 2.11, R 1.0, & PICMG 2.0, R3).
15	+5V	+5V power
16	RSVD2	Reserved pin, uncommitted
17	IPMB_SDA	Connected to power supply IPMB_SDA pin.
18	IPMB_SCL	Connected to power supply IPMB_SCL pin.
19	IPMB_PWR	Connected to power supply IPMB_PWR pin.
20	RSVD3	Reserved pin, uncommitted

**\*\*\*Female ribbon connector mate for blue/black header is FCI 66900-020LF**

**\*\*\*Female socket connector is Amp 1-87456-6, contacts Amp 87667-5**

Sensing connections should be made using twisted pairs, with each sense signal paired with SENGDND. There are 3 SENGDND pins available for this.

The sense wires should not be routed alongside the other power cables to minimize noise pickup. Excessive noise on the sense lines will not significantly affect regulation since the variations are too fast. However, a noise spike may trigger the over-voltage protection circuitry that has a relatively fast response time. This would cause the power supply to intermittently shut down for no apparent reason.

## 4.5 Local or Remote Voltage Sensing

The 47-pin power supply connector provides voltage measurement (sensing) capabilities for the 5V, 3.3V, and +12V power rails.

Voltage sensing on the backplane is accomplished through one of the following:

**ATX Connector Sensing:** The ATX headers provide a method to measure the voltage at the destination. Voltage measurements made at each ATX connector are averaged through 1 Ohm summing resistors. This measurement average is fed to the power supplies for power supply voltage correction.

(ATX connector is J3 on 4626-11 and J3 & J4 on 4626-12 and J4, J5 & J6 on 4626-14)

**Control Header Sensing:** The 20-pin black/blue control header can also be used to provide remote sensing on boards where there is no ATX connection. (JP1 on all series 4626)

**Local Sensing:** A local 2x4-pin sense header provides a means to bypass the external sense inputs and use the power plane as the sense input. When shunted (jumpered), the voltage is sensed locally on the backplane. See the following pin-out for 'local' sense capability: (JP2 on all series 4626)

### JP2 Pinout

Jumper	Voltage Sense	Notes
JP2 pins 1&2	+12V sense	Shunted by default to force local +12V sensing.
JP2 pins 3&4	+3.3V sense	Open by default to force remote sensing.
JP2 pins 5&6	+5V sense	Open by default to force remote sensing.
JP2 pins 7&8	GND sense	Open by default to force remote GND sensing.

## 4.6 Geographic Address Configuration for 4626-11 (single-slot)

There is one set of 3 jumpers (JP3) used to set the physical address of the slots. Pin identification of jumpers is silkscreened on the board (see mechanical drawing for 4626-11, page 12).

Use the chart on page 11 to set the geographic address jumpers. The pin numbers refer to the pins of the 2x3 header used to create the jumpers.

### 4.6.1 Geographic Address Configuration for 4626-12 (2-slot) & 4626-14 (3-slot)

There are two or three sets of 3 jumpers (JP3 & JP4, JP5) used to set the physical address of the slots. Pin identification of jumpers is silkscreened on the board (see mechanical drawing for 4626-12, 4626-14 page 13 - 16).

Use the following chart on page 11 to set the geographic address jumpers. The pin numbers refer to the pins of the 2x3 header used to create the jumpers.

### 4626-Series Geographic Address Settings

<b>Physical Slot Assignment</b>	<b>Pin 1, 2</b>	<b>Pin 3, 4</b>	<b>Pin 5, 6</b>
0	Jumpered	Jumpered	Jumpered
1	Jumpered	Jumpered	Open
2	Jumpered	Open	Jumpered
3	Jumpered	Open	Open
4	Open	Jumpered	Jumpered
5	Open	Jumpered	Open
6	Open	Open	Jumpered
7	Open	Open	Open

5.0 Mechanical Drawings  
 5.1 4626-11 (single slot)

**4626-11 FRONT**

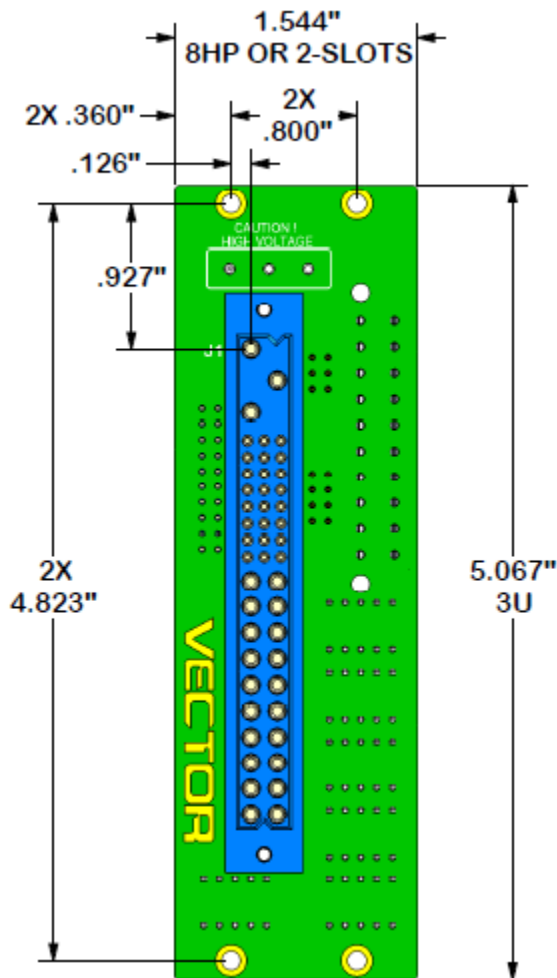

**4626-11 REAR**

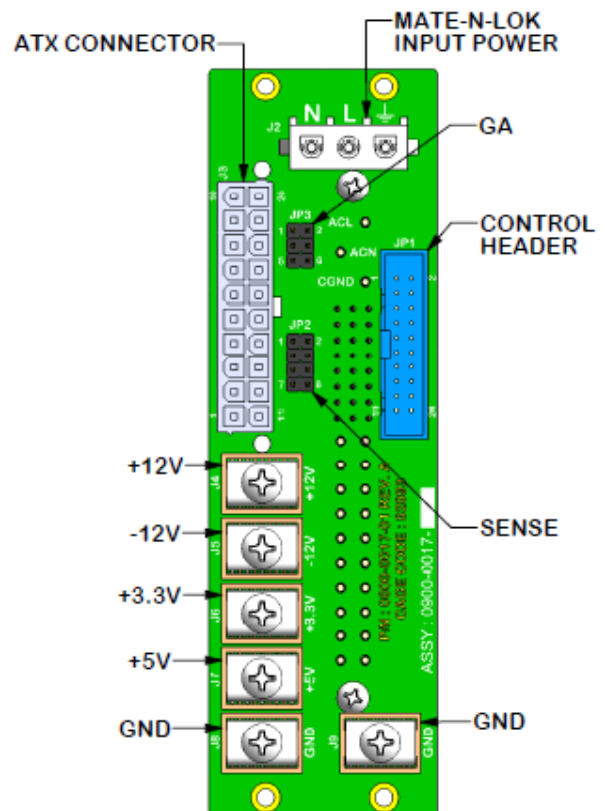

PCI47-style, 'P47' Connector (blue shown) can also be grey or black

5.2 4626-12 (dual slot)

4626-12 FRONT

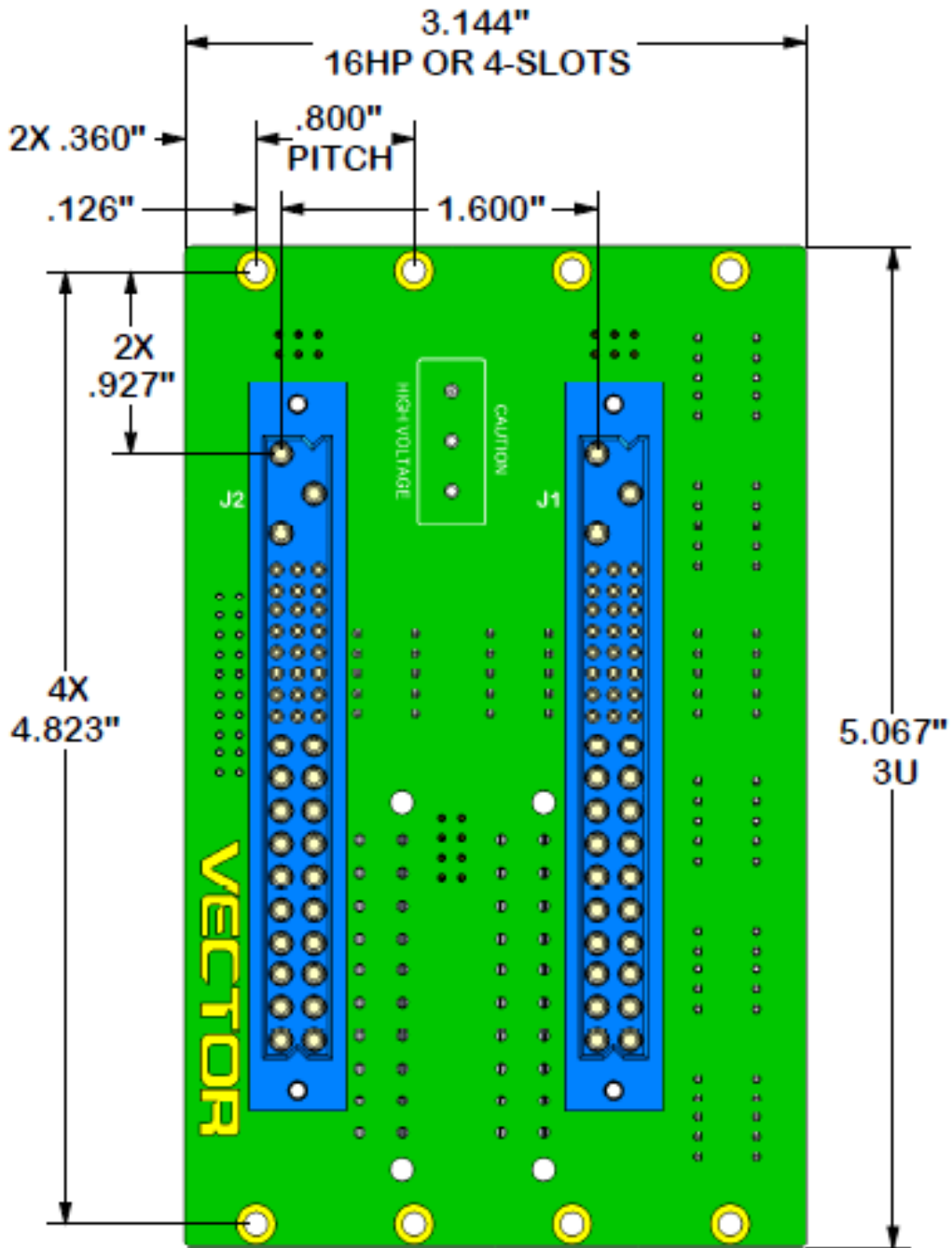

PCI47-style, 'P47' Connector (blue shown) can also be grey or black

**4626-12 REAR**

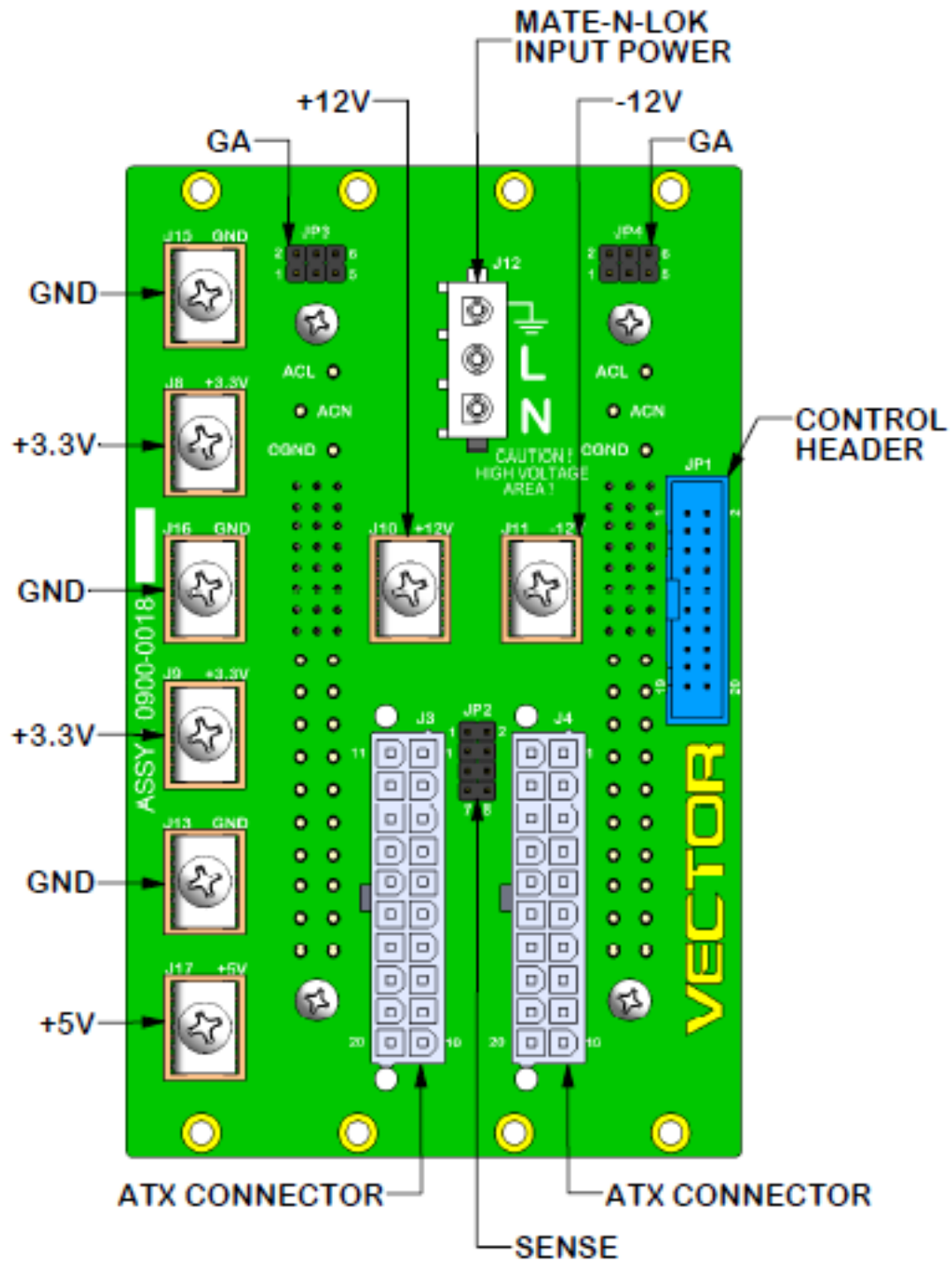

### 5.3 4626-12 (Triple-slot)

#### 4626-14 FRONT

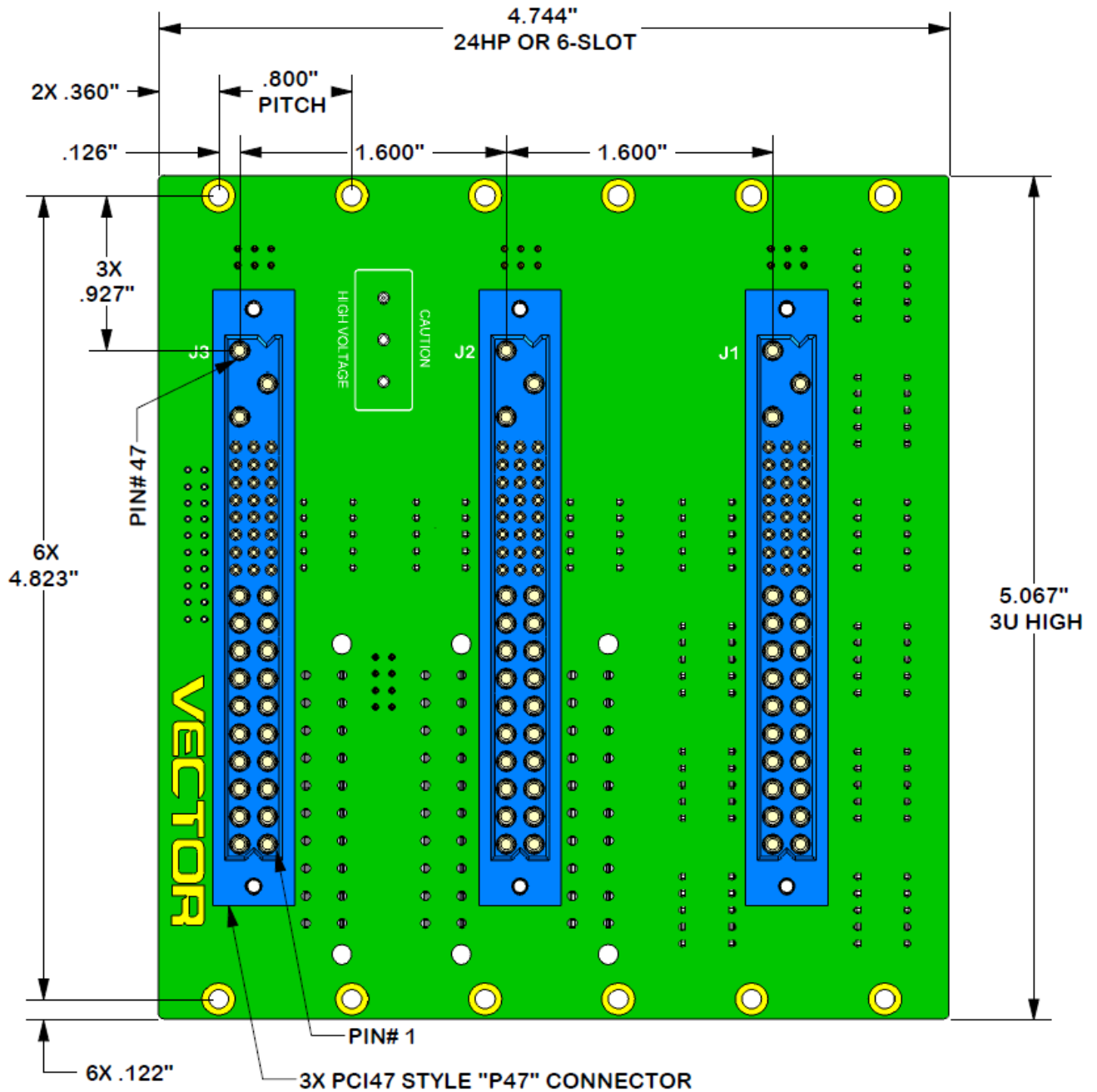

**PCI47-style, 'P47' Connector (blue shown) can also be grey or black**

**4626-14 REAR**

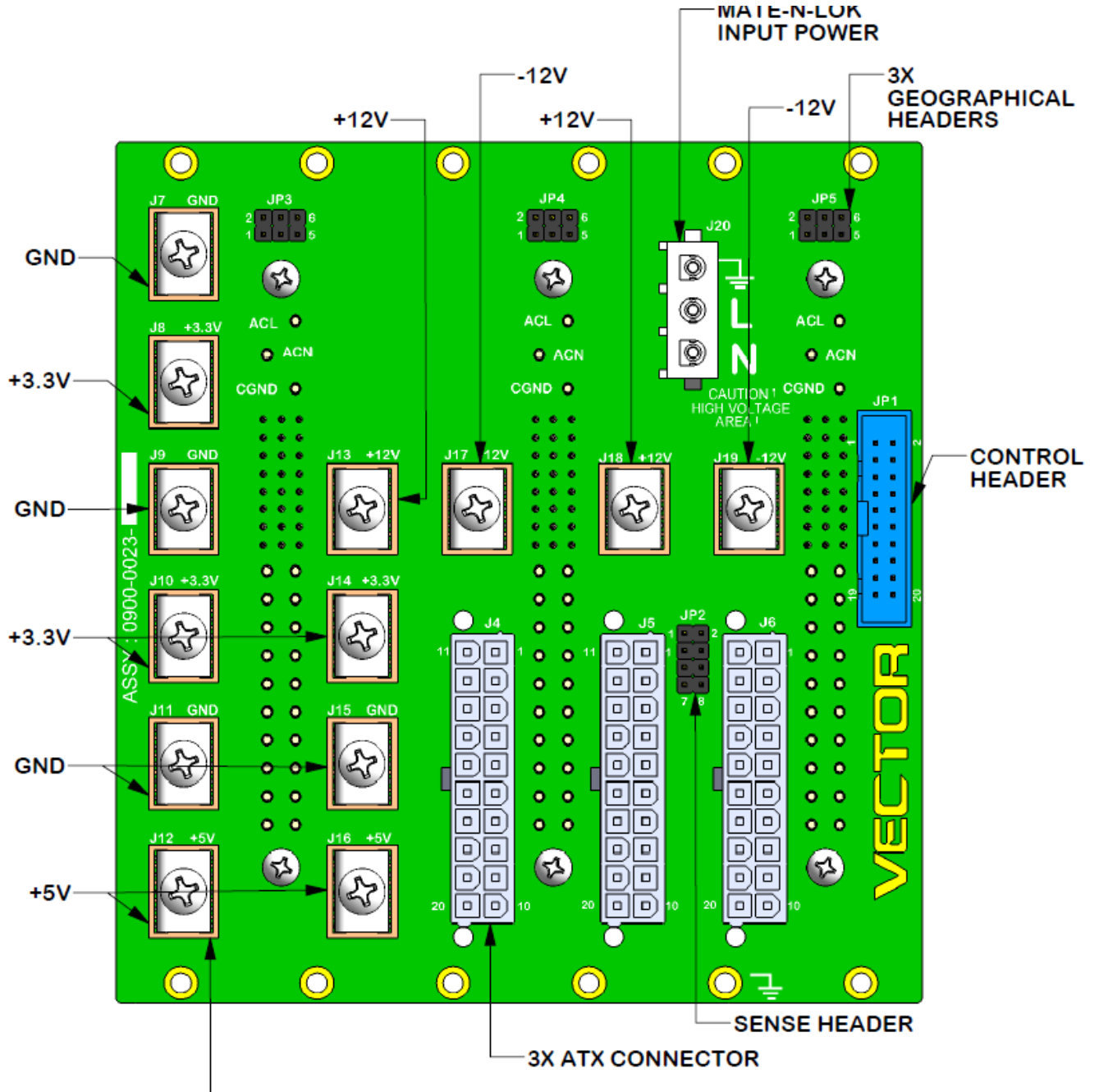



**4626-24 FRONT**

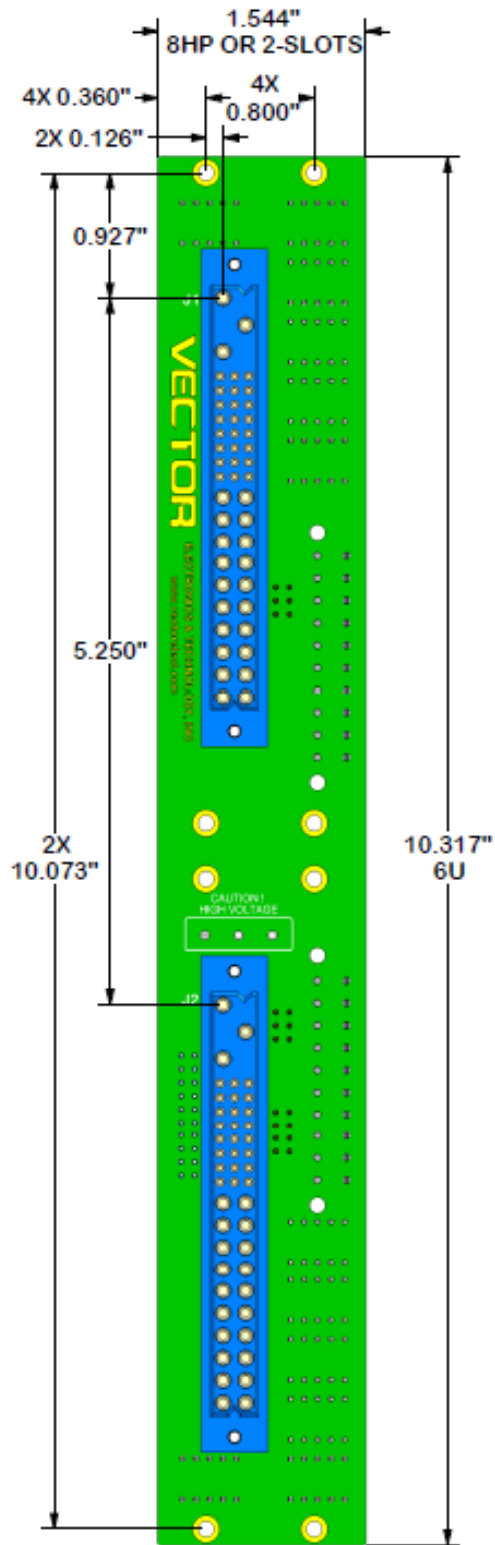

## 4626-24 REAR

