

4

3

2

1

- 1. CAD generated drawing - Do not update manually. This drawing to be used for reference only. Detailed model information is available from SolidWorks 3D files.
- 2. Decimal tolerances .X = ±.1 .XX = ±.01 .XXX = ±.005 unless noted.
- 3. Break all sharp edges to .01" unless noted.
- 4. Parts to have minimal burrs, sink marks and flash.
- 5. Material- Polypropylene (20% GF)
- 6. Color- Black.
- 7. EDM finish on all outer surfaces. No texture required on internal surfaces.

REVISIONS				
ZONE	REV.	DESCRIPTION	DATE	APPROVED

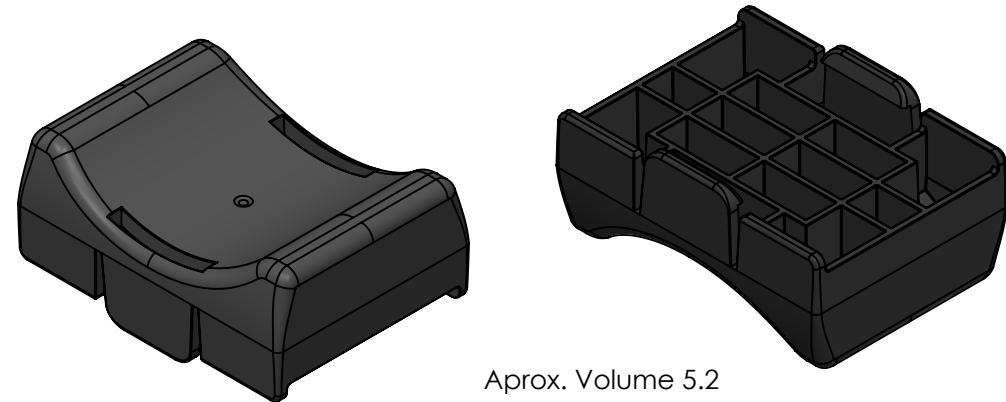

Aprox. Volume 5.2 cubic inches

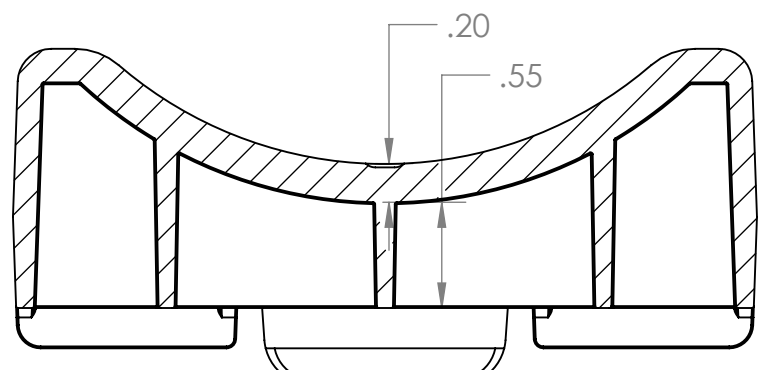

SECTION A-A

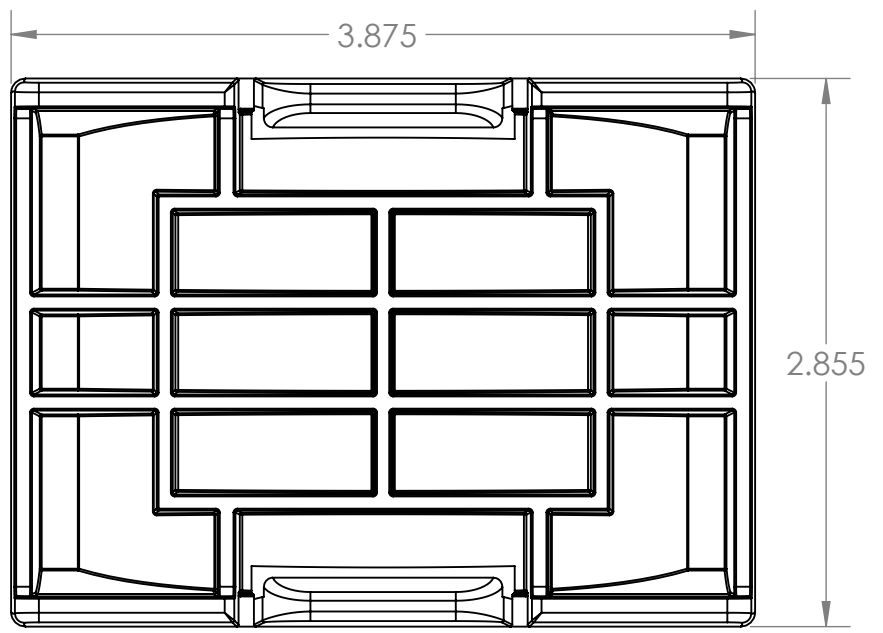
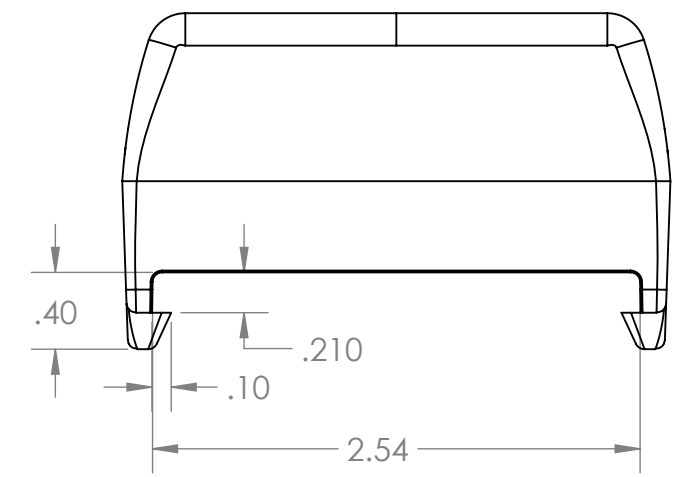
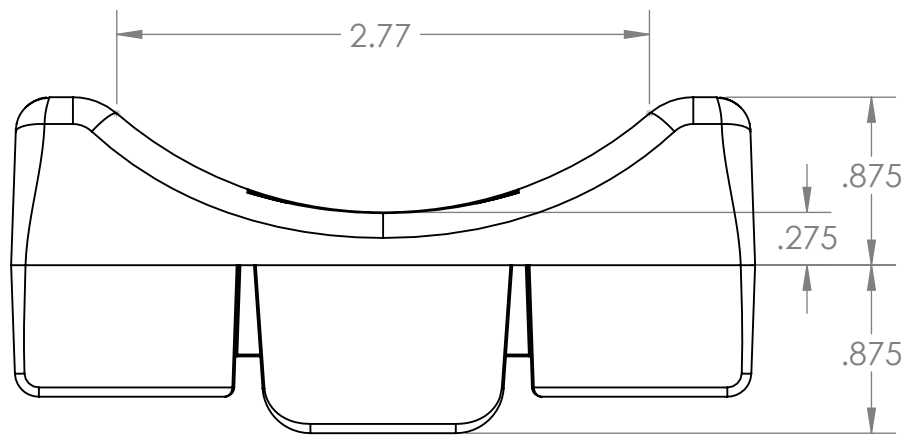
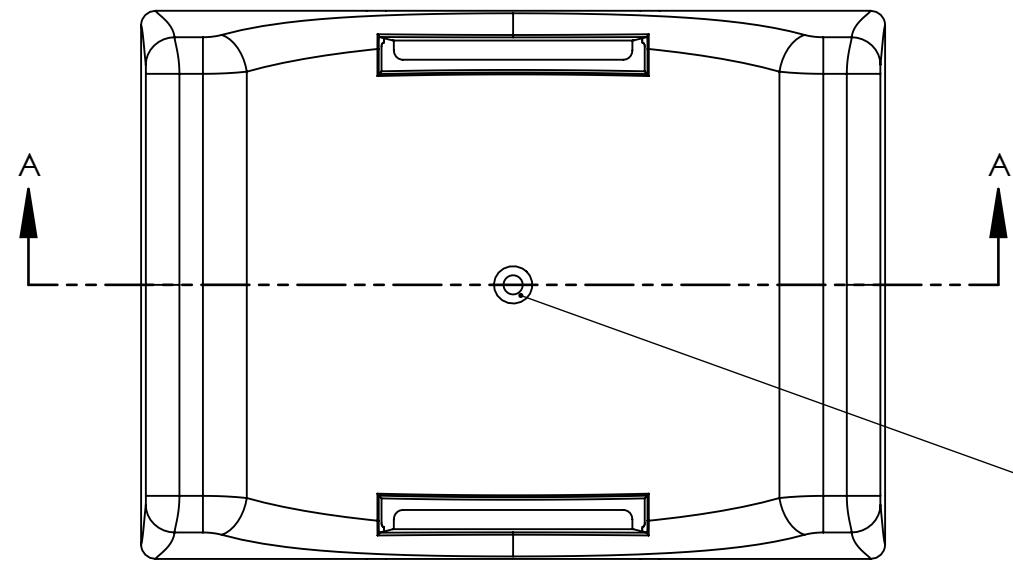

Poly Saddle is compatible with the following brackets/Cable Stanchions/Rack Arms

Consolidated Edison
1 Way - 2 Way - 3 Way
Fabricated Brackets

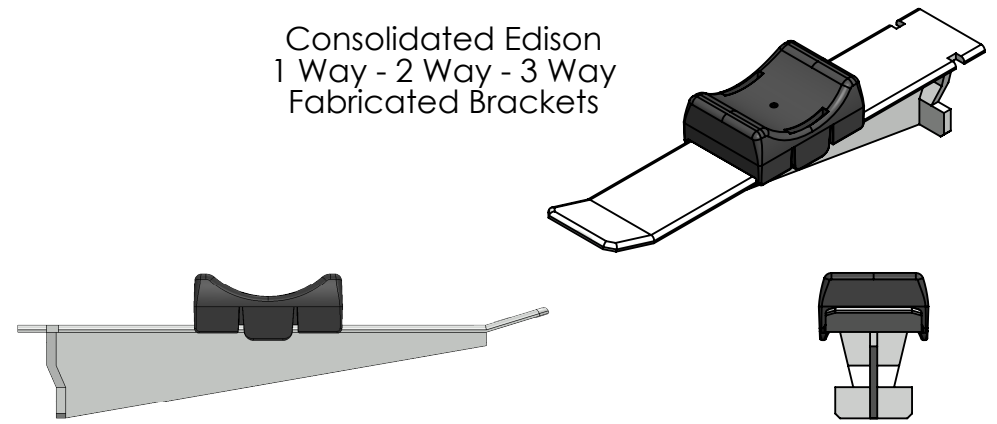

Saddle needs to fit over stock brackets. Will develop a test fixture for in process checks.

POLY-SADDLE



PROPRIETARY AND CONFIDENTIAL

SIZE B	DWG. NO. Poly Saddle (ConEd)	
SCALE: 1:1	DATE: 12-3-2018	

4

3

2

1