

Owner's Manual

IW-K7

IW-J7

IW-LCR7

IW-D7

IW-CR7

Snell

SPECIFICATIONS	IW-CR7	IW-K7
Frequency Response ($\pm 3\text{dB}$)	80 Hz-20 kHz	78 Hz-20 kHz
Recommended Amplifier	50-150W	50-125W
Nominal Impedance	4 ohms	8 ohms
Sensitivity (2V.83v at 1m)	88dB SPL	87dB SPL
Tweeter	1" Vifa silk dome, ferrofluid cooling	1" SEAS silk dome, ferrofluid cooling
Bass Driver	2 - 4-inch (102mm) treated paper cone with butyl rubber surround, 5mm excursion	5 $\frac{1}{4}$ -inch (132mm) treated paper cone with butyl rubber surround, 5mm excursion
Crossover Point	2.5kHz	2.5 kHz
Composite Baffle	Specialty adhesive between two $\frac{1}{4}$ " layers of HD fiberboard	Specialty adhesive between two $\frac{1}{4}$ " layers of HD fiberboard
Grille	Perforated metal, 53% open	Perforated metal, 53% open
Dimensions (HxWxD)	17 x 10 $\frac{1}{2}$ x 3 $\frac{3}{4}$ inches (432 x 267 x 95mm)	14 x 9 $\frac{1}{2}$ x 3 $\frac{3}{4}$ inches (356 x 241 x 95mm)
Rough Opening Cutout (HxW)	15 $\frac{7}{8}$ x 9 $\frac{3}{8}$ inches (403 x 238mm)	12 $\frac{7}{8}$ x 8 $\frac{3}{8}$ inches (327 x 212mm)
Finish*	White trim, suitable for painting	White trim, suitable for painting
Weight	10 lbs (4.5kg) / each	6 lbs (2.7kg) / each

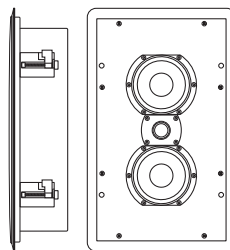

IW-CR7

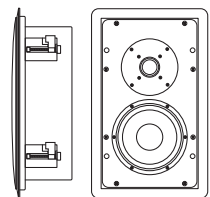

IW-K7

IW-J7	IW-LCR7	IW-D7
66 Hz–20 kHz	70 Hz–20 kHz	62 Hz–20 kHz
50–150W	50–250W	50–250W
8 ohms	4 ohms	4 ohms
87dB SPL	89dB SPL	90dB SPL
1" SEAS silk dome, ferrofluid cooling	1" SEAS silk dome, ferrofluid cooling	1" SEAS silk dome, ferrofluid cooling
6 1/2-inch (165mm) copolymer with butyl rubber surround. 5mm excursion	2 - 5 1/4-inch (132mm) treated paper cone with butyl rubber surround, 5mm excursion	2 - 6 1/2-inch (165mm) copolymer with butyl rubber surround, 5mm excursion
2.5 khz	2kHz	2kHz
Specialty adhesive between two 1/4" layers of HD fiberboard	Specialty adhesive between two 1/4" layers of HD fiberboard	Specialty adhesive between two 1/4" layers of HD fiberboard
Perforated metal, 53% open	Perforated metal, 53% open	Perforated metal, 53% open
17 x 10 1/2 x 3 3/4 inches (432 x 267 x 95mm)	23 1/4 x 13 1/4 x 3 3/4 inches (590 x 336 x 95mm)	30 1/2 x 10 1/2 x 3 3/4 inches (775 x 267 x 95mm)
15 7/8 x 9 3/8 inches (403 x 238mm)	22 x 12 inches (559 x 305mm)	29 3/8 x 9 3/8 inches (746 x 238mm)
White trim, suitable for painting	White trim, suitable for painting	White trim, suitable for painting
9 lbs (4kg) / each	19 lbs (8.6kg) / each	19 lbs (8.6kg) / each

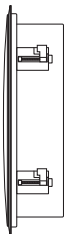

IW-J7

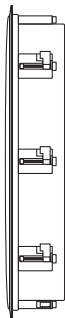
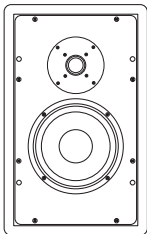

IW-LCR7

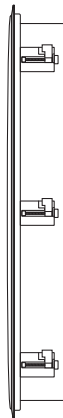
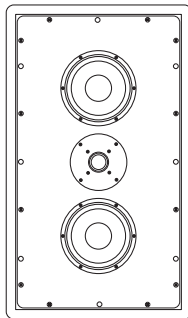

IW-D7

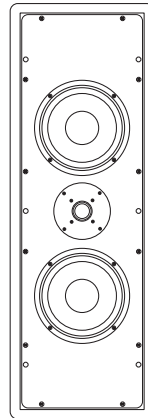

INTRODUCTION: WHAT IS A HIGH END IN-WALL?

The new Snell IW series units bring a novel approach to the design and construction of in-wall loudspeakers, expanding the boundaries of in-wall performance.

Our primary goal was to develop loudspeakers that delivered performance that was as close as possible to that of our highly regarded freestanding loudspeakers, like the K7 and LCR7. To do this several issues had to be addressed.

The bass performance of conventional loudspeakers mounted in wall cavities is very unpredictable. Cavity volume can be large, which should be good for bass performance. However, with one very short dimension (approximately 4") and one very long dimension (up to 8'), the wall cavity takes on the characteristics of a closed-end organ pipe. This creates a strong resonance that tends to null out the bass. Lining this cavity with fiberglass will reduce the "Q" of the notch but not restore the bass. What is needed is a defined volume of a more regular size. This is best done with fully enclosed in-wall speakers.

The Snell IW loudspeaker enclosure is a thin, but strong, aluminum tub. It is both damped and braced. This largely contains the back radiated sound of the woofer within the enclosure. An added benefit of containing the woofer output is a reduced chance that resonances will be excited in the house walls. Furthermore, sound "bleed through" to adjacent rooms is reduced.

To minimize resonances in the Snell enclosure, the speaker baffle uses a technique first pioneered on our .5 and XA series loudspeakers. The baffle is a three part composite with MDF (fiberboard) outer layers around a thin, but highly effective, damping layer. This controls the panel resonances of the baffle that can obscure midrange clarity. As we have found with our freestanding loudspeakers, a better loudspeaker cabinet means a better sounding loudspeaker.

In addition to these unique solutions, all traditional Snell attributes are retained. Highly coherent in-phase crossover networks ensure a seamless blend from driver to driver. Drivers are designed for smooth, wide range response and low distortion. Long sessions of listening and adjusting give each system that special, characteristic Snell sound. Finally, that Snell sound is guaranteed in every production pair by Snell's proprietary 0.5dB production tuning techniques.

PLACEMENT OF THE FRONT CHANNEL SPEAKERS

A home theatre system includes three loudspeakers placed across the front of the listening room. The distance between the left and right speakers determines the width of the stereo image. If the speakers are placed too close together, the image will be too narrow; too far apart and the blend will suffer, creating a hole in the middle. When properly placed, your speakers will create a continuous "virtual image" from left to right, with an illusion of sound outside, in front of, and behind the speaker systems.

We recommend an angular separation between 45 degrees and 60 degrees (when viewed from above). This is equivalent to a separation between the speaker systems that is about 85% of the distance to either of the speakers.

Creation of sounds between the speakers requires some precise placement. The distance from the left speaker, right speaker, and center channel to the listener location should all be as equal as possible. We advise using a tape measure to equalize these two distances to the primary listening location.

Ideally the front channel speakers should be installed at the same height as the ears of a seated listener. Try to keep the front channel tweeters within two vertical feet of that height.

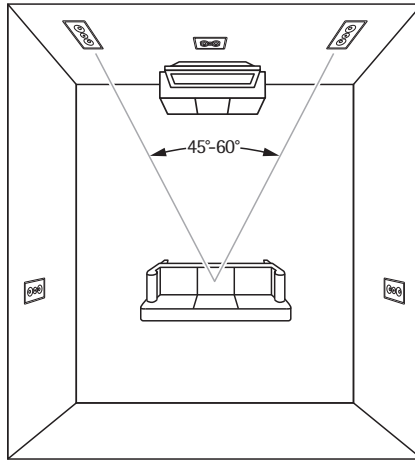

PLACEMENT OF THE SURROUND SPEAKERS

There are many opinions about where surround or "rear" speakers should be mounted. The following is based on the findings of the best academics, and on our experience with many installations. These placement recommendations apply to all the IW models.

If two surrounds are used in a standard 5.1 configuration (not 7.1 or EX), they are best mounted to the sides of the listening area. This means straight to the sides of the listener or in line with the primary row of seating, plus or minus 15 degrees. This is preferred over back wall mounting for several reasons: It places the surrounds at locations where the difference between left ear and right ear discrimination is at a maximum. This gives the maximum sense of "envelopment" or being surrounded by sound. Rear mounted speakers force a huge angular gulf between the front primary speakers and the rear speakers. The sound image is inherently discontinuous. Also, front to rear aural discrimination is not very strong. Differentiation between front and rear speakers will not be as strong as the effect of adding speakers to the side. 7.1 or EX systems that use side and rear speakers together overcome all of these obstacles and give both maximum envelopment and a more continuous surround effect.

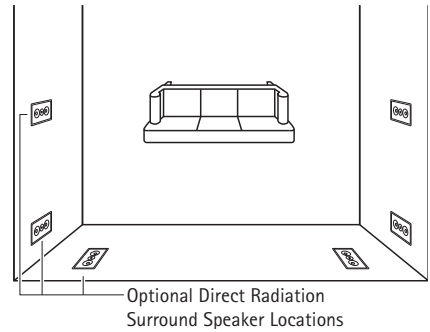

A second factor to consider is the evenness of sound coverage over the seating area. Most surround processors have features for setting the balance of all channels. A circulating noise signal is adjusted in each channel until the apparent or measured sound level is even. Of course, moving to another seat will shift this balance somewhat. Well-placed surround speakers will minimize the level variation from seat to seat. The best way to achieve evenness is to increase the distance of the surround speakers from the listening area. Mount them high on the side walls or even on the ceiling. As a good rule of thumb, surrounds should be on the side walls at least one foot above the height of a standing listener. If the speakers are ceiling-mounted, they should be close to the side walls, well away from an overhead position.

If a large theater room with three or more rows of seats is planned, then more than one pair of surround speakers should be used to give more even coverage and a more diffuse sound field. We recommend that a pair of surrounds be used for every other seating row (the first, the third, the fifth, etc.). This follows standard cinema practice.

INSTALLATION INSTRUCTIONS

IMPORTANT: This manual assumes that the installer possesses skill in the proper use of hand and power tools, knowledge of local building and fire codes, and a familiarity with the environment behind the wall or ceiling in which the speakers will be installed.

Optional preconstruction brackets are available for each model.

PAINTING THE SPEAKERS

If you intend to paint the speakers, it is best to do so before installation.

- 1) Remove the speaker grille.
- 2) Mask the baffle.
- 3) After painting, carefully remove the paint mask.

Note: Custom paint and grilles are available for an extra charge.

PREPARING FOR INSTALLATION

Map out the wiring paths from the speakers to the amplifier. We recommend 16-gauge wire for runs up to 25 feet, and 14-gauge wire for longer runs. Be sure the speaker wire does not rest or rub against any sharp or pointed objects.

The speakers should be mounted on a flat surface to form a good seal between the speaker flange and the mounting surface.

When connecting more than two speakers per amplifier channel, you should use series/parallel wiring. In all cases, make certain that the total impedance does not fall below the amplifier's rating. If you are not sure, contact your Snell Acoustics dealer.

You will Need:

- 1) A utility knife, an electric jigsaw, or other means of cutting a hole in the mounting surface.
- 2) A #2 Phillips screwdriver.
- 3) A wire cutter or stripper for preparing the speaker wires.

With the supplied hardware, the speaker can be installed in existing walls or ceilings from 1/2" (12mm) to 1 1/2" (38mm). For thinner walls, you will need to use spacers for the mounting legs (contact your Snell dealer for this optional rubber part).

INSTALLATION

For convenient installation, these Snell IW series speaker systems use a dog-leg mounting system (see illustrations below). This provides a quick and clean install. Furthermore, the dog-legs can be removed if a particular situation requires the speaker to be directly attached to a stud.

- 1) Make an appropriate size speaker mounting cutout in the wall material.
- 2) Run the wire from the amplifier to the cutout. Allow an extra foot of wire at the cutout. Strip 1/2" (12mm) off the wire, and tightly twist the wire strands together.
- 3) Remove the speaker grille.
- 4) Insert the speaker wires into the spring terminal binding posts mounted in the terminal cup.

Push down on the terminal to open the hole for the wire and insert the wire. Release the terminal to clamp the wire in place.

Important: The speaker wire may be color coded as illustrated here. Or it may have a ridge or stripe on the insulation of one of the conductors. Use the color coding or marks to be sure the + terminal of the speaker is connected to the + terminal on the amplifier, and the - terminal of the of the speaker is connected to the - terminal of the amplifier.

All the speakers in the system must be connected the same way to get proper performance.

Warning! To prevent electrical shock, always switch off the amplifier or receiver when making connections to the speaker system.

- 5) Place the speaker into the rough opening.
- 6) Level the speaker and tighten the screws, being careful not to over tighten them. See illustration below for details.
- 7) Replace the speaker grille.

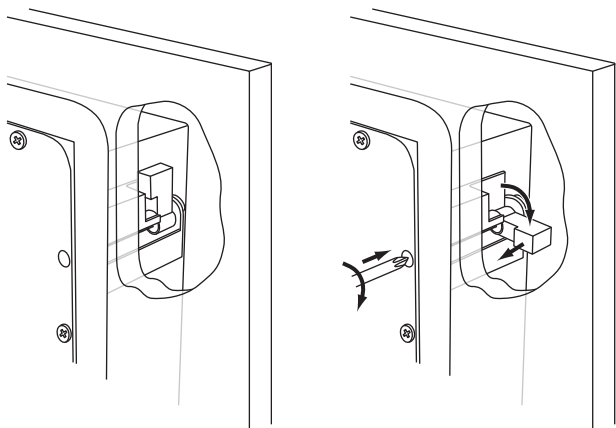
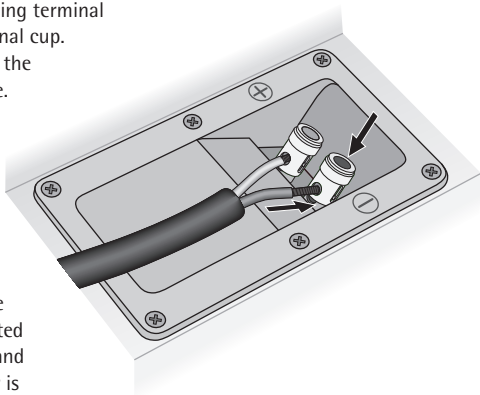

Turn the mounting clamps against the enclosure, then place the speaker in the mounting hole. Use a phillips head screwdriver to deploy the mounting clamps and pull them against the back of the drywall.

LISTENING LEVELS AND POWER HANDLING

The power recommendation for the system assumes you will operate the amplifier in a way that will not produce distortion. All speakers can be damaged by even a modest amplifier if it is producing distortion. If you hear a gritty noise or other signs of strain, turn down the volume. Prolonged or repeated operation of your speakers with a distorted signal can cause damage that is not covered by the warranty. It is especially important that you do not overdrive the bass capability of smaller speakers. Watch for noises, such as pops, caused by the music's bass line. Use of the loudness control and/or full bass boost at louder volumes is likely to overdrive the woofer. Use such controls sparingly.

HOW TO CARE FOR YOUR SPEAKERS

- ▶ Use a soft terry cloth towel slightly dampened with water, glass cleaner, or a diluted mild detergent. The towel should be just damp enough to wipe the surface clean without leaving a trail of moisture.
- ▶ Do not use abrasive cleaners or any cleaner containing chemicals harsher than those found in glass cleaner.

LIMITED WARRANTY

For five years from the date of purchase, Snell Acoustics will repair for the original owner any defect in materials or workmanship that occurs in normal use of the speaker system, without charge for parts and labor.

Your responsibilities are to use the product according to the instructions supplied, to provide safe and secure transportation to an authorized Snell Acoustics service representative, and to present proof of purchase from an authorized Snell dealer in the form of your sales slip when requesting service.

Excluded from this warranty is damage that results from abuse, misuse, accidents, shipping, repairs, or modifications by anyone other than an authorized Snell Acoustics service representative. This warranty is void if the serial number has been removed or defaced.

This warranty gives you specific legal rights, and you may also have other rights that vary from state to state.

If Service Seems Necessary

Contact the dealer from whom you purchased the speaker system. If that is not possible, call us at 607-352-2488, or write to:

Snell Acoustics
2 Chambers Street
Binghamton, NY 13903

We will promptly advise you of what action to take. If it is necessary to return your speaker system to the factory, please ship it prepaid in the original factory packaging. Please note that Snell Acoustics will not be held liable for shipping damage due to improper packaging. After it has been repaired, we will return it freight prepaid in the U.S. or Canada.



For EU Customers Only

This symbol found on the product indicates that the product must not be disposed of with household waste. Instead, it may be placed in a separate collection facility for electronic waste or returned to a retailer when purchasing similar product. The producer paid to recycle this product. Doing this contributes to reuse and recycling, minimizes adverse effects on the environment and human health and avoids any fines for incorrect disposal.

©2009 Snell Acoustics. All Rights Reserved.
Specifications are subject to change without notice.
Covered by patents issued and/or pending.
Part #542-1063

Snell

2 Chambers Street
Binghamton, NY 13903-2699
phone: 607-352-2488
fax: 607-352-2498
email: info@snellacoustics.com
www.snellacoustics.com