

**D Systems Residential Fire Pump**  
13D Compliant Pump Submittal Data Sheet-  
3HP Dcono Package

**Model F-302-D**

**Pump Data**

- 3HP 5-1/4 Imp, 1 Stage Centrifugal Pump
- 316L SS Corrosion Resistance Construction
- Built-In Overload , Auto-Reset Provided
- 15.5amp 230V Single Phase UL Motor
- \*110V not available
- 1-1/2 F IPT Suction

**Pump Flow**

( not for certification use )

GPM	0	30	40	60	80	100
PSI	48	46	45	42	38	33

**Components**

- A - Flow Switch
- B - 1-1/2 Galvanized Riser F IPT
- C - Supervised Control Valve
- D - Pressure Gauge
- E - D Panel Control Box with Full Steel Frame
- F - 40 60 Pressure Switch
- G - Bypass Line w/ 3/4 Backflow Preventer
- H - 3 HP Pump
- \*Wiring in Liquid Tight Conduit (not shown)

**Check Box for Optional Equipment**

- I - Butterball Tamper Switch

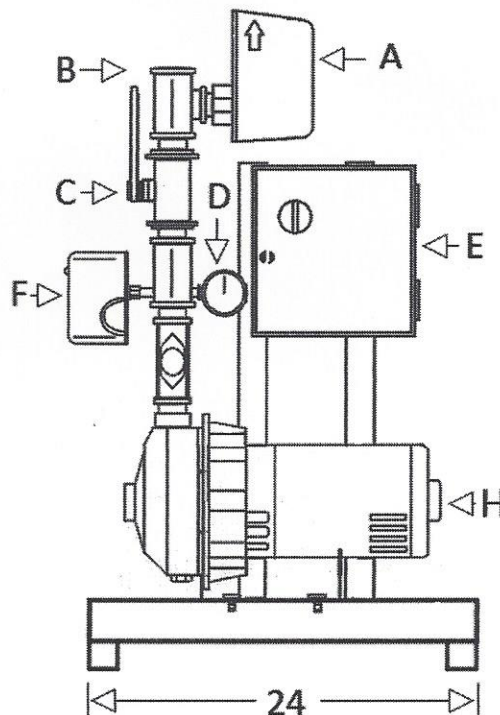
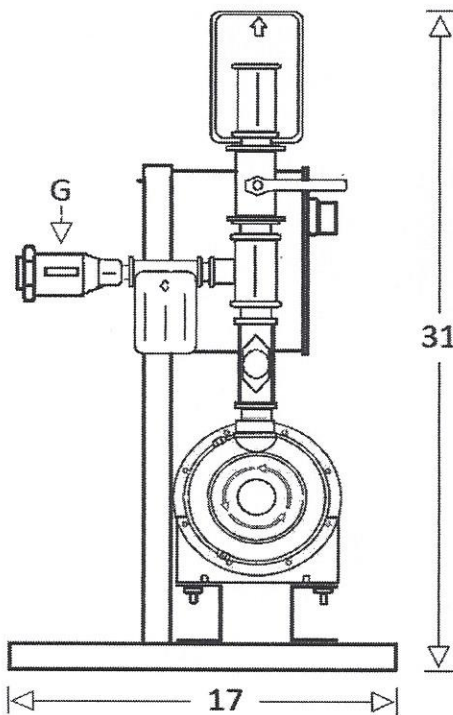

\*Note: all measurement in inches