

All Hampden Products are Made in The USA

MILITARY TRAINING

GSA Contract Pricing in Place
Contract # GS-02F-0208R

LOOK INSIDE!
For the new
Tier 2 and 3
Trainers

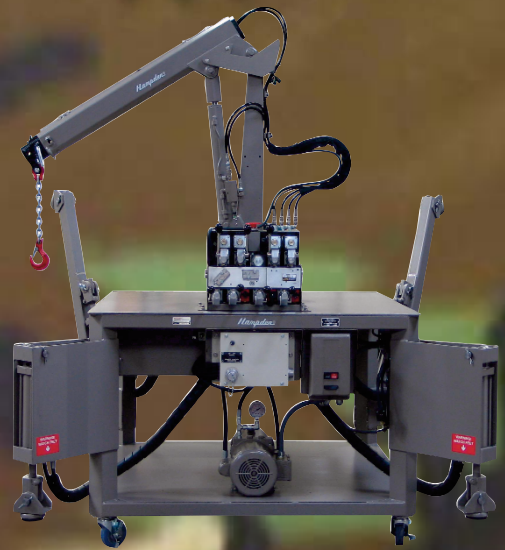
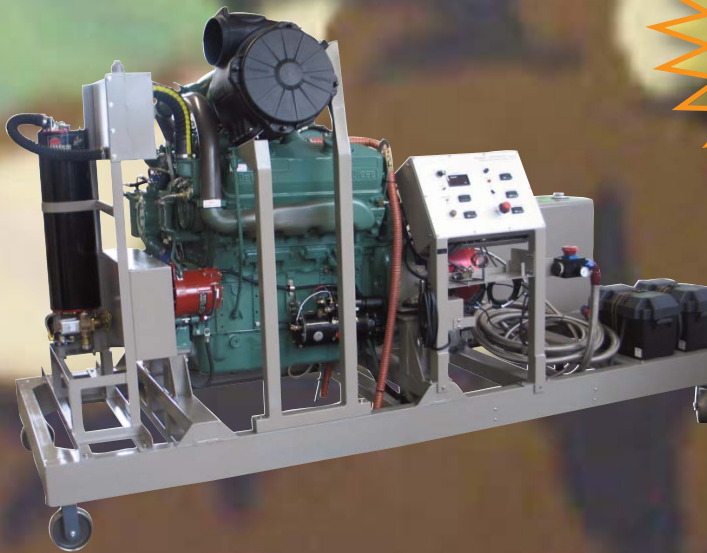

Hampden[®]
ENGINEERING CORPORATION



MILITARY TRAINING

GET THE HAMPDEN H-AACT-HMMWV Humvee Air Conditioning Trainer

Model H-AACT-HMMWV

Humvee Air Conditioning Trainer provides students with the ability to learn the air conditioning cycle found in a military Humvee, including measurements of pressure, vacuum, flow rate, and temperature.

The H-AACT-HMMWV

consists of an actual HMMWV frame, body, and rear hatch mounted on a 2" x 2" welded furniture grade steel mobile carrier, finished in instrument tan enamel.

Included are six castors, four with locks.

(No doors or windows are provided.)

Hampden
customizes training units
for the military
as well as schools and
industrial applications.

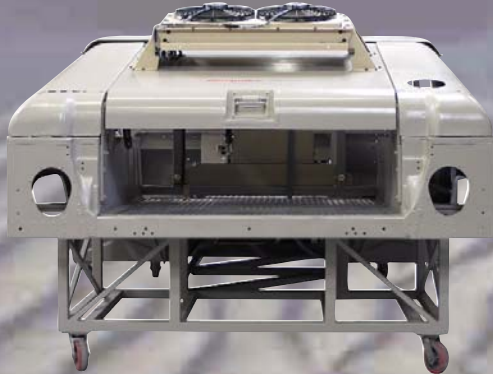

Mounted on the rear hatch is a Red Dot brand air conditioning system.

This system is fully functional; the compressor is located in the engine compartment and is coupled to a five horsepower electric motor.

The electric motor is controlled via a Baldor variable frequency drive (VFD).

An electrical power cord with cord wrap is provided.

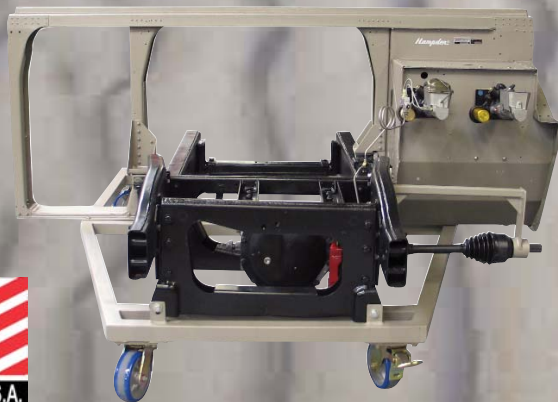

← H-BST-HMMWV

Hampden Braking System Trainer
for Humvee, front drivers Side Section
Mounted on a Mobile Frame



Standard Products...Designed to Meet Your Growing Needs!

DON'T GET STUCK WITHOUT TRAINING

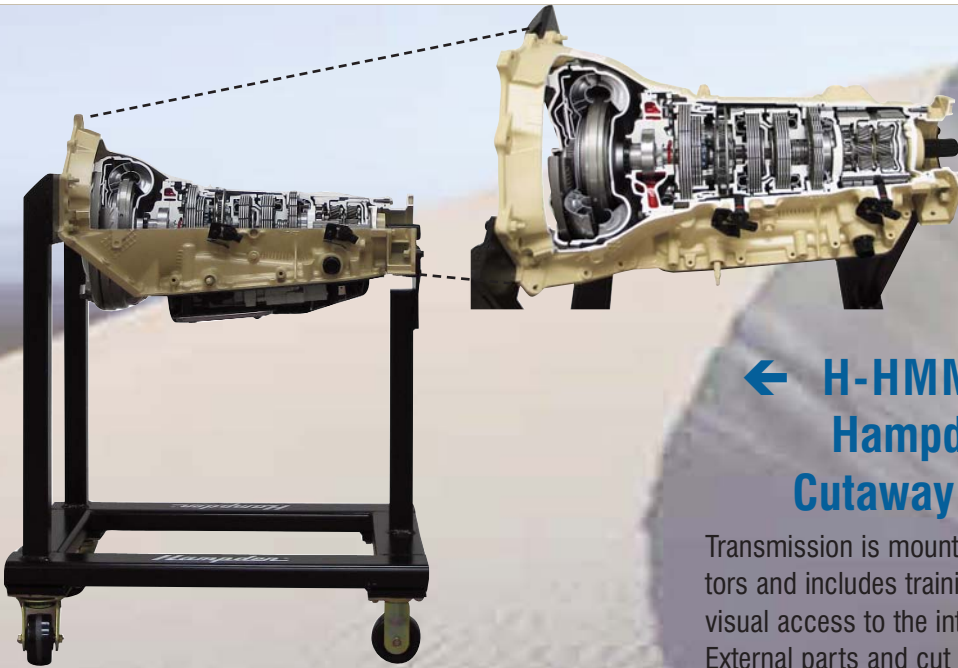

← H-HMMWV-4L80E-CA Hampden Humvee Cutaway Transmission

Transmission is mounted on a steel base with castors and includes training cutaway areas to provide visual access to the internal working components. External parts and cut surfaces will be painted.

Model H-CD-46-RC → Four-Cycle, Six-Cylinder Digital Diesel Engine Simulator



←H-PLS-BSTT Palletized Load System Air Brake with Cutaway Axle

The front axle of a LMTV will be mounted on a steel base with castors. The braking system will be fully operational with the air actuators being plumbed back to a lever operated pneumatic switch. The center of the axle assembly will be cutaway to provide visual access to the internal parts, the opening will be shielded with plastic covers for safety.





MILITARY TRAINING

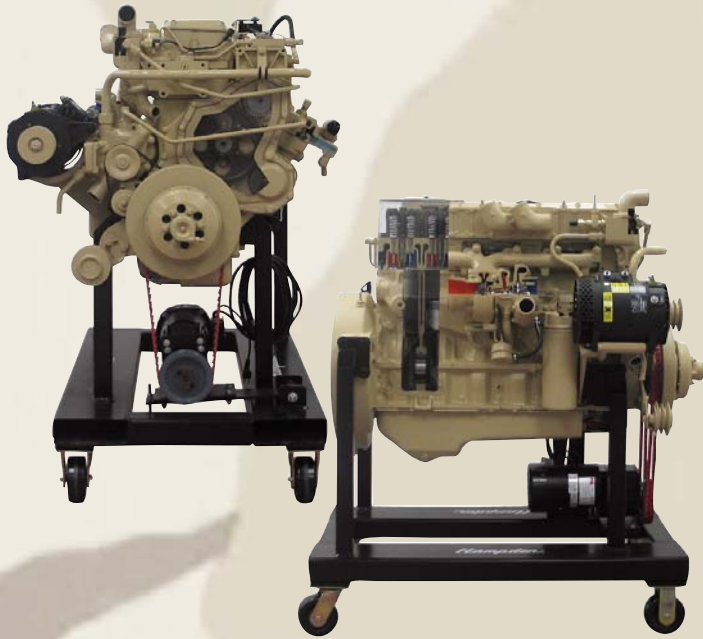

**H-CAT-3116-CA
Caterpillar Engine Cutaway
on Mobile Stand**

Cutaway Engines

Engine is mounted on a steel base with drive motor and castors.
Training cutaway areas on engine will include:

- Thermostat Housing
- Cylinder Head
- Valve Cover
- Air Intake
- Water Pump
- Oil Pan
- Manifold
- Fuel Pump
- Fuel Pickup Pump
- Engine Block
- Lube Pump
- Front Gear Housing

External parts and cut surfaces will be painted. Internal working parts will be lubed for rotation (approximately 3 RPM)
Openings will be shielded with plastic covers for safety.

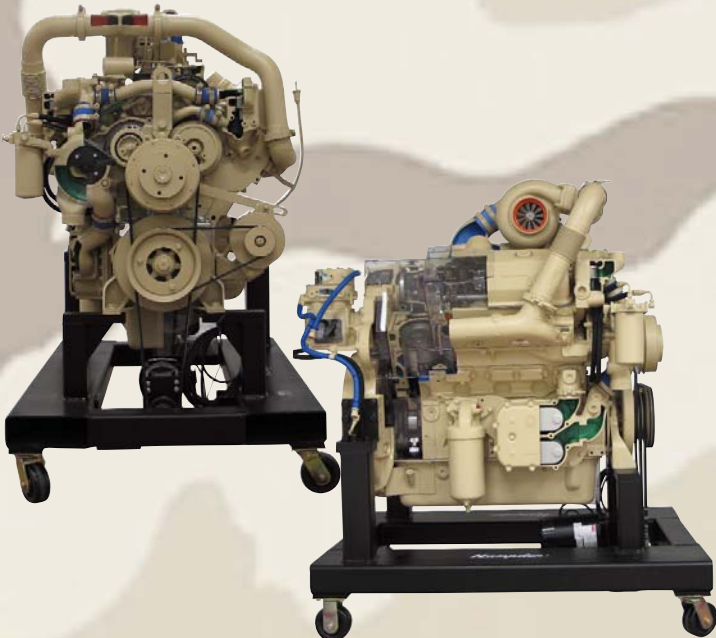

**H-DET-8V-92TA-CA
Detroit Engine Cutaway
on Mobile Stand**

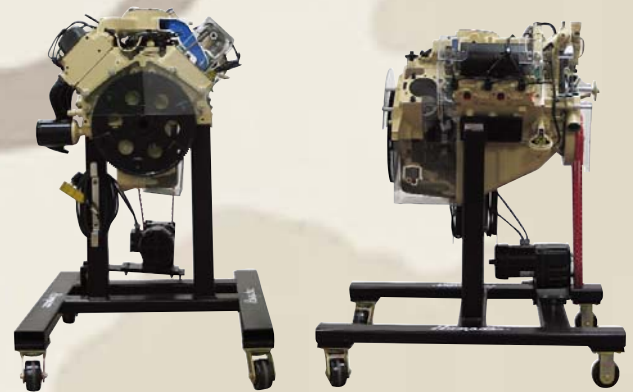

**H-HMMWV-6.2-CA
Humvee Engine Cutaway
on Mobile Stand**

***Everything
you ever wanted to know
about your
Humvee Motor***



MILITARY TRAINING

Working Engines

Engine with Dynamometer is mounted on a mobile stand/frame with control panel. The performance of the engine can be monitored on both the control panel and on a computer via the included data logging package. Coupled to the engine is a 19" toroid water-brake with the ability to load a 1,000 hp motor. The water-brake will allow the engine to be tested at full load. Hampden Working Engines will include:

- Engine
- Fuel Tank 50 gal. with level gauge
- Control Panel with:
 - Digital Water Temperature Display
 - Digital Tachometer
 - Digital Volts Meter
 - Digital Amp Meter
 - Digital Oil Pressure Display
 - Digital Fuel Pressure Display
 - Key Start Switch
 - Throttle Control
 - Emergency Stop with Reset
- Batteries (2)
- DC to AC Inverter
- Cooling Tower (Replaces the Radiator and Fan Blade)
- Dynamometer with Load Valve

H-CAT-3116 Caterpillar Engine on Mobile Stand with Dynamometer

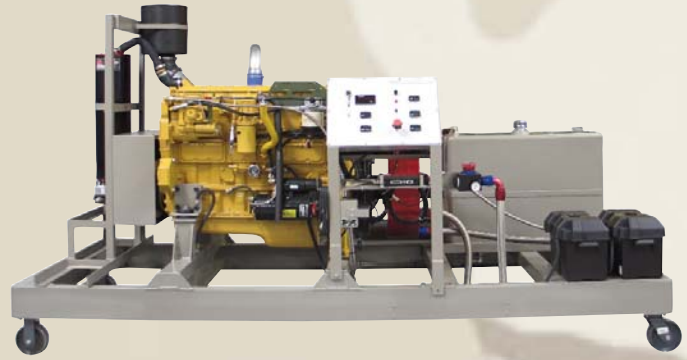

H-DET-8V-92TA Detroit Engine on Mobile Stand with Dynamometer

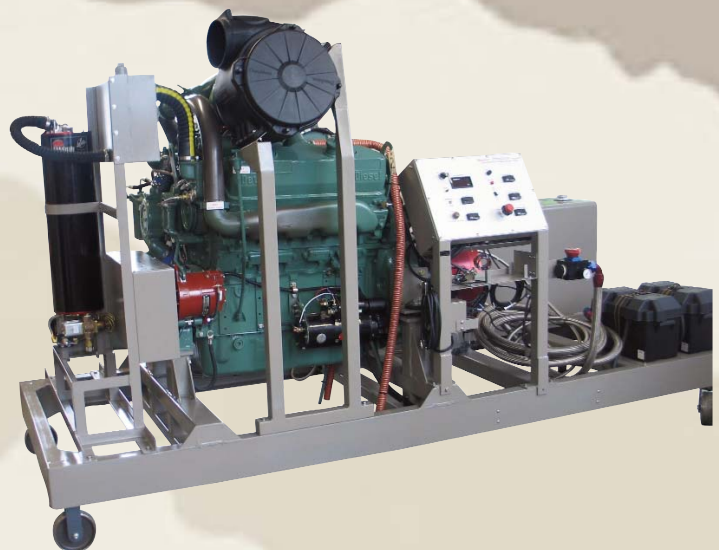

Panel used for H-DET-8V-92TA and H-CAT-3116



MILITARY TRAINING

State-of-the-Art Classroom Training

H-HEMTT-1 Hemtt Hydraulic Crane System Trainer

Model H-HEMTT-1
Hemtt Hydraulic Crane System Trainer is a fully operational crane system that simulates the actions of a H-HEMTT-1 crane. It uses one main control system to control all of the components of the crane. The unit consists of a control system with emergency stop located on top of the control box, the crane itself positioned on the center of the bench, two outriggers located on the front corners of the unit, two support pistons on the back two corners, the hydraulic pump located under the bench and the start and stop controls for the hydraulic pump. The crane also has three movement controls. It can move rotationally 270 degrees, extend the arm outward 4ft, and can lift its arm up and down. Each of the levers on the control system controls one of these motions. There is also a sensor system that controls one lockout solenoid on the control system. The H-HEMTT-1 also comes with insertable faults which are located in the fault box with locking door. ▶

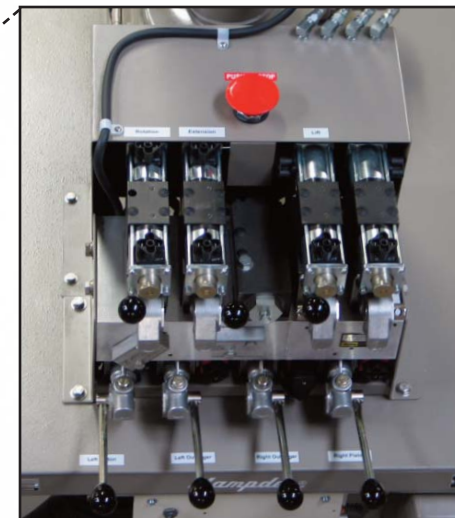
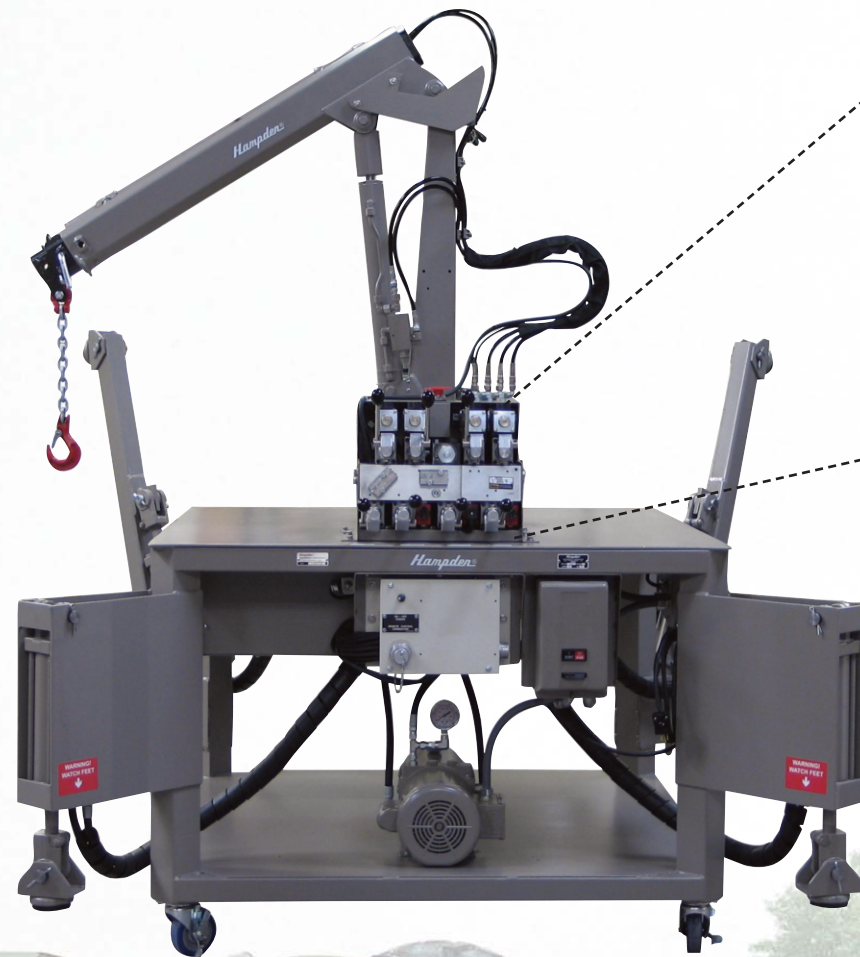

The control system on the H-HEMTT-1 consists of seven levers on a control block connected to a hydraulic pump. These seven levers control the motions of the crane, the two outriggers and two support pistons. The top three levers control the cranes extension rotation and lift motions and the bottom four control the outriggers motions. The crane also comes with sets of solenoids for each valve. The solenoids can be energized to operate the crane exactly as the hand levers do. The unit does not power the solenoids, but the solenoids are still attached to the valves.

The crane used on this unit is a Maxilift M50.2 Ant Crane. It has a swing angle of 270 degrees and three directions of motion; rotational, extension, and vertical. The maximum amount of weight that should be lifted with this unit is 200 lbs as it is to be used strictly to demonstrate how to operate a crane and not to be used for physical work.

The front two outriggers fold down and extend outward to give more support to the unit while the back two pistons shoot straight down to give support to the unit. Each outrigger and piston has a rubber foot attached to give support and traction. The outriggers and pistons can lift the unit about 1" above the floor it sits on for leveling if need be.

H-SCRC-1 Thyristor and Power Electronics Trainer

The H-SCRC-1 Thyristor and Power Electronics Trainer is a simulation of twelve (12) specific faults which can occur in the operation of a 60-Ton Topside Crane. The purpose of the trainer was to train technical operators in the procedural steps to follow for fault resolution. The controls and display meters on the trainer panel give the operator vital feedback necessary in resolving a fault.

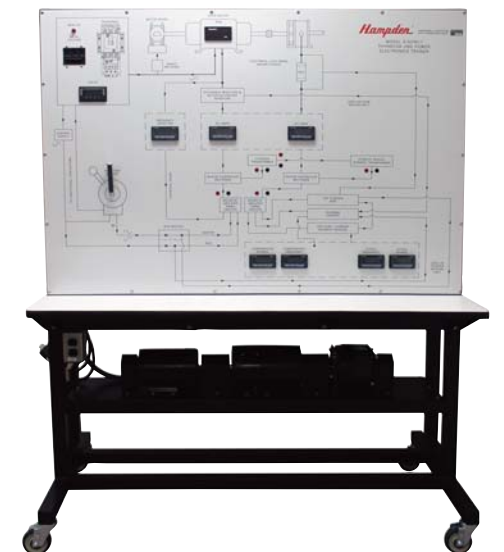

Standard Products... Designed to Meet Your Growing Needs!

MILITARY TRAINING

Hydraulic Trainer

Model H-FP-223-14 Hampden Hydraulic Trainer consists of a mobile bench, hydraulic pump, and selection of hardware mounted on a vertical panel. All hydraulics hardware is of commercial quality and configured for training purposes.

The following are mounted within the bench:

- LIQUID LEVEL GAUGE
- BALL VALVE
- NEEDLE VALVE
- PRESSURE RELIEF VALVE
- 3-GPM GEAR PUMP
- SOLENOID SELECTOR SWITCH
- 8 FOOT POWER CORD AND CORD RACK.
- ELECTRIC MOTOR W/VIBRATION AND ISOLATION MOUNTS
- 10 GALLON RESERVOIR WITH FILLER BREATHER CAP
- MOTOR STARTER SWITCH W/OVERLOAD PROTECTION
- THERMOMETER
- 10 MICRON FILTER
- PRESSURE GAUGE
- VACUUM GAUGE
- AERATION FILTER
- VENTING BALL VALVE

The following components are mounted on the panel:

- ▶ FLOW CONTROL VALVES
- ▶ NEEDLE VALVES
- ▶ PRESSURE GAUGES
- ▶ TEES
- ▶ HEADER FOR RETURN AND DRAIN
- ▶ PRESSURE REDUCING VALVE
- ▶ HYDRAULIC CYLINDER W/CLEAR TUBE AND TAPERED CAM
- ▶ HYDRAULIC MOTOR WITH LEXAN® SHAFT GUARD
- ▶ HOSES WITH QUICK CONNECT FITTINGS
- ▶ LEVER OPERATED 4-WAY DIRECTIONAL CONTROL VALVE
- ▶ PRESSURE COMPENSATED FLOW CONTROL
- ▶ SOLENOID OPERATED 4-WAY CLOSED CENTER DIRECTIONAL CONTROL VALVE
- ▶ CHECK VALVES
- ▶ FLOWMETER
- ▶ HYDRAULIC CYLINDER
- ▶ CROSS
- ▶ SEQUENCE VALVE
- ▶ DECELERATION VALVE
- ▶ HOSE RACK
- ▶ HEADER FOR PRESSURE

Optional Equipment—

- ▶ **H-FP-223-14-FP** Hampden Hydraulic Fault System Option
- ▶ **H-FP-223-14-P** Hampden Pneumatics Option
- ▶ **H-FP-223-14-PPS** Hampden Pneumatic Air Supply Option
- ▶ **H-FP-223-14-JS** Hampden Joystick Option
- ▶ **H-FP-223-14-EH** Hampden Electrohydraulics Option
- ▶ **H-FP-223-14-A** Hampden Accumulator Option
- ▶ **H-FP-223-14/15-CD** Software for Hydraulic and Pneumatic

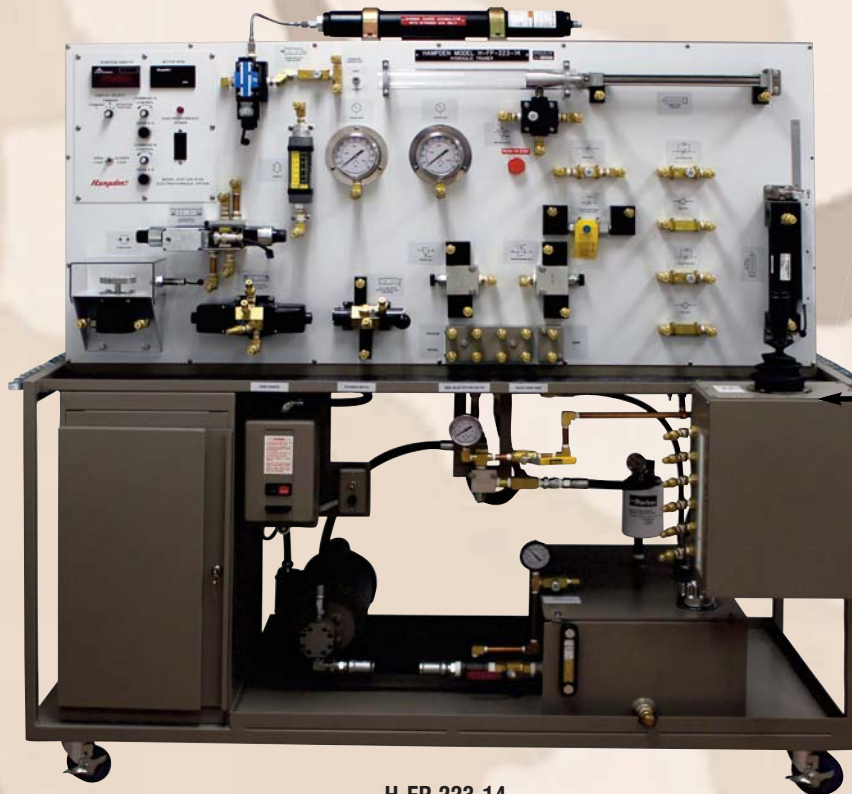

H-FP-223-14
Shown with A Option, EH Option, FP Option and JS Option

Standard Products...Designed to Meet Your Growing Needs!

Knowledge Is Power

Hydraulic Trainer – double sided



**** Cover your Tier 2 and Tier 3 Training ****

The Hampden Model **H-FP-223-14-JS** Joystick Option can be easily added to any existing Hampden **H-FP-223-14** Hydraulic Trainer.

H-FP-223-14-JS
Joystick Option

H-FP-223-14-FP
Optional Fault System

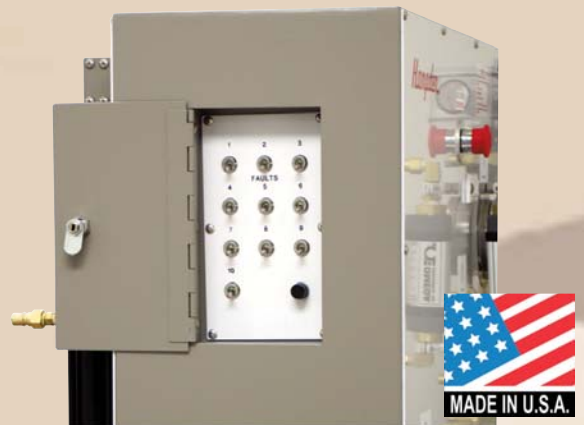

MADE IN U.S.A.

Standard Products...Designed to Meet Your Growing Needs!



State-of-the-Art Classroom Training

Air Conditioning and Refrigeration Systems

Hampden has a wide variety of Refrigeration Trainers and Demonstrators

Model H-RST-7A Truck Refrigeration System Trainer

The Hampden Model H-RST-7A Truck Refrigeration System Trainer is a practical hands-on refrigeration system trainer used to familiarize the student with the design concepts and operating procedures of Thermo King Transport Refrigeration systems.

The Trainer is a completely functional refrigeration-heating type system. The equipment is securely mounted on a mobile stand and arranged to provide maximum accessibility for both instructor and students. Each component, which is clearly labeled, is of commercial quality and is typical of the kind encountered in the field. ▶

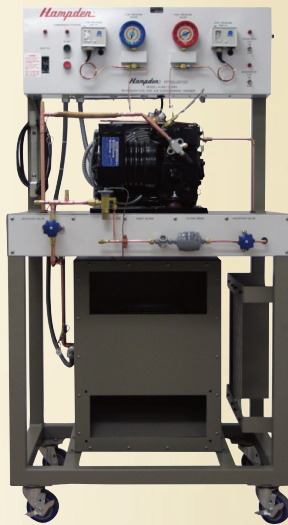

Model H-RST-5 Refrigeration and Air Conditioning Trainer

The Hampden Model H-RST-5 Refrigeration and Air Conditioning Trainer is a thermostatic expansion valve (TEV) controlled refrigerating system which provides the basic facilities for studying the principles, mechanics and maintenance aspects of industrial refrigeration systems.

The H-RST-5 consists of a mobile demonstration carrier with base and compressor mounting frame and an instrument/control panel. Gauges read evaporation and condensing pressures, while strategically located temperature wells permit temperature measurements. The lower portion of the workbench houses the evaporator with its fan, permitting the compressor to cycle based on evaporating pressure. The trainer is provided with faulted components which the instructor can temporarily install in place of the functioning components. The fault system includes: Air Flow Restrictor, Deflection Shield, TEV-Faulted Orifice, TEV-Faulted Screen, and Faulted Filter-Drier. The H-RST-5 is R-134a based and is completely factory assembled and tested. ◀

Model H-RST-11 Red Dot Air Conditioner Trainer

The Hampden Model H-RST-11 Red Dot Air Conditioner Trainer Provides a hands-on introduction to the principal components of a Red Dot Brand air conditioning system. This trainer utilizes the air conditioning system incorporated in a HMMWV military vehicle. ▶

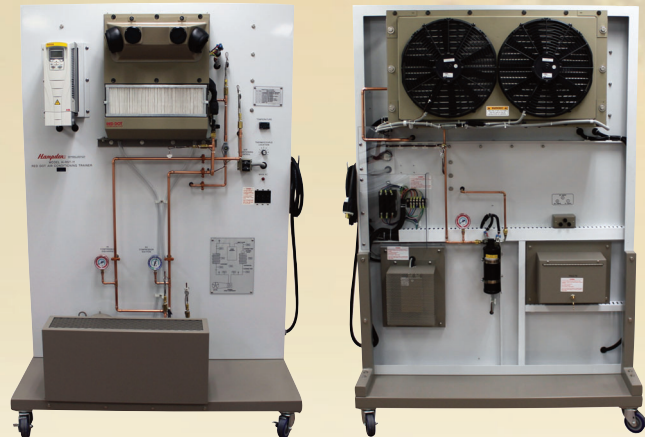

H-RST-11 Red Dot Air Conditioner Trainer
Front View and Back View



State-of-the-Art Classroom Training

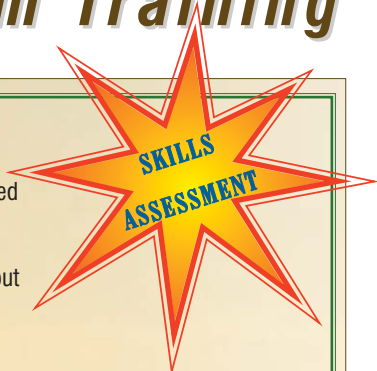

Automotive Simulators

MODEL H-AUTO-BS

demonstrates brake system fundamentals, featuring disc and drum brake theory and repair.



Hampden's line of **Computer Assisted Panel Instruction Modules** have been designed to provide realistic System Operation & Troubleshooting functions to virtually **ANY CLASSROOM!**

Each module's front panel is silkscreened with a complete schematic & pictorial layout of all system operations and combined with actual test-point pushbuttons, LEDs and meters.

All units are controlled via a laptop computer (supplied) using supplied Hampden software and USB I/O Interface. Automotive Trainers are as follows:

- H-AUTO-ICS Charging System Simulator
- H-AUTO-SB Storage Battery Simulator
- H-AUTO-BS Braking System Simulator (shown)
- H-AUTO-CS Cooling System Simulator (shown)
- H-AUTO-SS Starting System Simulator
- H-AUTO-AH Automotive Heating Simulator
- H-AUTO-LS Lighting System Simulator
- H-AUTO-ED Electrical Diagnosis Simulator
- H-AUTO-FDS Fuel Deliver System Simulator
- H-DAACS-CSI Air Conditioning Simulator (shown)

MODEL H-DAACS-CSI demonstrates the principles of operation and troubleshooting of current factory installed AC systems.



MODEL H-AUTO-CS

demonstrates cooling system fundamentals, troubleshooting and repair. Radiator status is presented.



Mechanical Maintenance



H-1500-BVC-B
Ball Valve
Cutaway w/ Base



H-1500-GVC-B
Globe Valve
Cutaway w/ Base



H-1500-PVC-B
Plug Valve
Cutaway w/ Base



H-1500-RVC-B
Safety Relief Valve
Cutaway w/ Base



H-1500-UVC-B
Butterfly/Diaphragm
Valve Cutaway w/ Base

▶ **Hampden Cutaways** allow for convenient classroom training for the operation, construction, and maintenance of common industrial components. Through carefully planned sectioning and color-coding, the complete internal configuration of each component is exposed and showcased. Seal features and hardware locations have been retained.

Model H-181-100B Steam Boiler Trainer

efficiently provides hot water for process heat and building heat typically used throughout industry. This trainer teaches technicians the skills they need to select, operate, install, maintain and repair basic steam systems. ▼

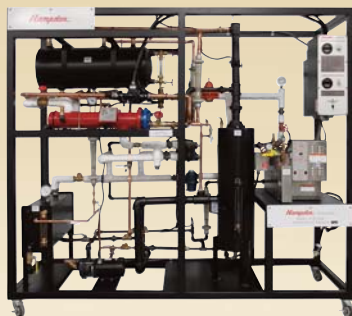

Model H-6645X Series/Parallel Pump Trainer

is a tabletop unit for the operation and investigation of series and parallel pump operation. The trainer consists of two dual speed centrifugal pumps that are fed by two common water reservoir tanks that can be used separately and a clear PVC plumbing arrangement, along with valves that allow various configurations to be implemented. ▼



INSTRUMENTS:

- Gauges (4)
- Digital Flow Meter (1)

ADD:

H-6648 Control Interface Module Option for Data Acquisition



MILITARY TRAINING

Motors and Motor Controls

- ◆ **MGB-100-DG** Bedplate with guards
- ◆ **DM-100A** DC Machine
- ◆ **SM-100-3** Synchronous Machine
- ◆ **CSM-100** Capacitor Start Motor
- ◆ **SPM-100** Split Phase Motor
- ◆ **IM-100** AC Induction Motor
- ◆ **WRM-100-3A** Wound Rotor Motor
- ◆ **MFM-100** Multi-function Machine
- ◆ **ACUM-100** AC Universal Motor
- ◆ **H-MGI** Motor Generator Interface
- ◆ **PB-100** Prony Brake
- ◆ **RL-100A** Resistance Load
- ◆ **RLC-100** Resistance-Reactance Load
- ◆ **DYN-100A-DM** Dynamometer
- ◆ **MS-100-3A** Magnetic Starter
- ◆ **SFR-100** Series Field Rheostat
- ◆ **PSI-100** Phase Sequence Indicator
- ◆ **HT-100K** Tachometer Generator/Indicator
- ◆ **T-100A** Single Phase Transformer
- ◆ **ACC-100** AC Controller with Faults
- ◆ **DCC-100** DC Controller with Faults
- ◆ **H-VFD-100C** Variable Frequency Drive
- ◆ **H-SCR-104** Four Quadrant DC Speed Controller
- ◆ **SIM-100** Virtual Motors and Machines
- ◆ **HDI-100** Dissectible Motors Program



**HMD-100-CM
Deluxe Mobile Console**

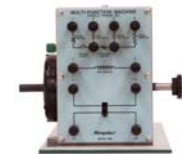
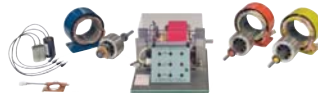

Transformer

**Model H-DTT-26
Transformer Lab Kit**
allows students to correctly make connections to power transformers located on utility poles.



Industrial Motor Controls

**Model GNR-H2200
Industrial Controls
Training System**
provides students with practical "hands-on" experience in designing, wiring, checking out, and troubleshooting "real-world" motor control systems.



Hampden is committed to providing industry-leading technology.

For the latest from Hampden, visit our home page at <http://www.hampden.com> or e-mail us at sales@hampden.com

