

THE WYOMING ARCHAEOLOGIST

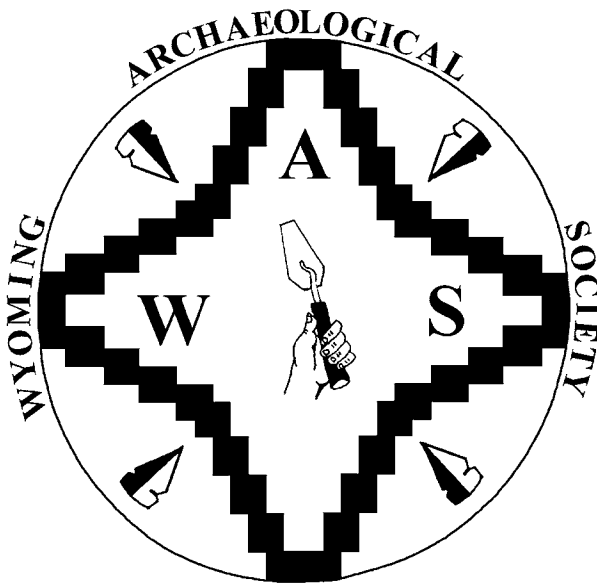

VOLUME 50(1)
SPRING 2006
ISSN: 0043-9665

[THIS ISSUE
PUBLISHED
JANUARY 2008]

THE WYOMING ARCHAEOLOGIST

VOLUME 50(1), SPRING 2006

Table of Contents

WYOMING ARCHAEOLOGICAL SOCIETY FINANCIAL DONATION FORM	2
IN MEMORIUM: RHODA OWEN LEWIS: 1943-2007.....	3
IN MEMORIUM: TIM NOWAK	4
NEWS AND ANNOUNCEMENTS	5
PRESIDENT PIPES: ORIGIN AND DISTRIBUTION by Michael A. Pfeiffer, Richard T. Gartley, and J. Byron Sudbury	9
LATEX PEELS: A METHOD FOR PRESERVING NATURAL AND CULTURAL STRATIGRAPHY by William Eckerle and Jenne M. Moe.....	31
HAFTED STONE TOOLS: A LOOK AT HUNTER-GATHERER EXAMPLES FROM THE CENTRAL AND NORTHWESTERN PLAINS by Cody Newton	35
WYOMING ARCHAEOLOGICAL FOUNDATION FINANCIAL DONATION FORM	48

THIS ISSUE PUBLISHED JANUARY 2008

**WYOMING ARCHAEOLOGICAL SOCIETY
MEMORIAL GIFT or CONTRIBUTION FORM**

Given by: Miss, Mrs., Mr., Ms., Dr. \$ _____
(Amount)

Name: Last First Middle

Address: City & State Zip

Donor phone number () _____

TYPE OF GIFT:

General Contribution [] **Specific Contribution** []

In Memory of: _____

Name City & State

In Honor of: _____

Name City & State

Specify where you would like your money to go (e.g., Mulloy or Frison Scholarship Funds, The Wyoming Archaeologist, ????????)

Please make your check payable to THE WYOMING ARCHAEOLOGICAL SOCIETY and send to Carolyn Buff, Executive Secretary/Treasurer, 1617 Westridge Terrace, Casper, WY 82604

IN MEMORIUM

RHODA OWEN LEWIS

1943-2007

Rhoda Lewis, a University of Wyoming alumnus, long time volunteer, member of the board of the Friends of the Frison Institute, Adjunct Lecturer at the Department of Anthropology since the fall of 2006, passed away Thursday evening, April 19, 2007.

Rhoda Owen Lewis was born in Medicine Lodge, Kansas on February 13, 1943 to Neil and Bertie Owen. On April 19 at the age of 64, she died peacefully in the company of family at Iverson Memorial Hospital in Laramie, Wyoming. She is survived by her sons Robert Craig and William Lee.

Rhoda earned a B.S. degree in Education from Chadron State College and an M.A. degree in Anthropology from the University of Wyoming. She worked in the field of archaeology for more than 30 years, retiring in 2005 from her position as Regional Archaeologist for the Fish and Wildlife Service in Denver, Colorado.

Since retirement, Rhoda had been supervising the construction of her new house, participating in the governance of the George C. Frison Institute as a board member and active volunteer, and was recently named as adjunct faculty at the Department of Anthropology at the University of Wyoming.

Rhoda was a strong advocate for higher education. In many ways, she was a poster child for the power of education to change the lives of people for the better. Her family has chosen to create the Rhoda Owen Lewis Memorial Fund, to be managed by the George Frison Institute. This fund will be to provide assistance to non-traditional students pursuing a degree in Archaeology or Anthropology at the University of Wyoming. Rhoda's estate



seeded the fund with an initial contribution. To maximize the effect of the donations, the family asks that they be made through the Wyoming Archaeological Foundation.

Send checks payable to the Wyoming Archaeological Foundation to the Rhoda Owen Lewis Memorial Fund, c/o George Frison Institute of archaeology and Anthropology, Dept. 3431, 1000 East University' University of Wyoming, Laramie, WY 82071-3431.

The editors of the Wyoming Archaeologist encourage members and other readers of the journal to submit obituary information about WAS members to the editorial staff in Laramie when such notices appear in local papers. We will then recognize the accomplishments of these members in the journal. Thank you.

IN MEMORIUM

TIM NOWAK 1947-2007



Timothy Ray Nowak, 60, of Cheyenne died July 31 at the University of Colorado Hospital in Denver following a five month battle with leukemia.

Tim was born June 3, 1947, in Fargo, N.D., and grew up in Moorhead, Minn. He received a bachelor's degree from the University of Minnesota in 1969 and a master's degree from Harvard University in 1972. As an archeologist specializing in Mayan cultures, Tim spent several years in Guatemala, where he was married to Ludy Annabella Morales Navarro from 1970 to 1976, and fathered two daughters, Ilka Vanessa and Danika Waleska.

Upon his return to the United States, he worked for the Corps of Engineers in Pierre, S.D., and was married to Ana Lucretia Gomar Barillas from 1977 to 1983. He married Pamela Sue Gieser in 1984 and the couple had one daughter, Katrina Gabrielle Nowak.

Tim was employed by the Bureau of Land Management (BLM) as senior archaeologist and Cultural Heritage program leader in Wyoming. He also served as the Wyoming BLM Native American program coordinator. He was the BLM Deputy Preservation Officer for Wyoming and a founding member of the national-level BLM Preservation

Board. Within Wyoming, he served on the Governor's Task Force on Context Development.

Tim had resided in Cheyenne for 14 years at the time of his death.

He was involved with the Cheyenne Little Theatre Players, was a board member of the Cheyenne Chamber Singers, and was a member of Gideons International. An active member of First United Methodist Church, Tim also organized and led several mission trips to Guatemala.

He is survived by his wife, Pamela Sue (nee Gieser) Nowak of Cheyenne; daughters, Ilka Vanessa Mora and her husband, Edgar of King, N.C., Danika Waleska Nowak and her husband, Sergio Faz of Guatemala City, and Katrina Gabrielle Nowak of Cheyenne; three grandchildren, Kathia and Erik Faz, both of Guatemala City, and Luca Mora of King, N.C.; a future son-in-law, Brandon Nelson of Cheyenne; a brother, Terry Nowak of Pensacola, Fla.; five nieces; and two nephews.

He was preceded in death by his parents, Walter Thomas Nowak and Dorothy Luella (Martell); and his brother Robert Thomas Nowak.

Wyoming Tribune Eagle -- 08/05/2007

NEWS AND ANNOUNCEMENTS



WYOMING ARCHAEOLOGIST SURPRISED WITH HIGH HONORS

Described as a credit to the U.S. Army and the citizens of Wyoming, Project Director Dave Reiss with the Office of the State Archaeologist was presented with the prestigious Honorary Wyoming Cowboy Colonel Award by the Adjutant General Maj. Gen. Ed Wright.

The award, founded by state statute, is presented to military and civilian personnel for outstanding efforts of direct and specific nature, according to Wyoming National Guard Chief of Staff Col. Tim Sheppard.

State Archaeologist Mark Miller and Department of State Parks and Cultural Resources Director Milward Simpson also took the podium to praise the work that Reiss has done.

Reiss was also presented an Adjutant General's Coin by Maj. Gen. Ed Wright. The coin, designed by Maj. Gen. Wright, has been presented worldwide to military and civilian individuals in recognition of excellence.

Since the early 1990s, Reiss has directed cultural resource investigations and surveys of Wyo-

ming Military Department training lands and facilities throughout the state. His efforts have positively impacted both the Wyoming Military Department and the National Guard.

Under his direction, more than 36,000 acres have been surveyed and more than 800 historical and archaeological sites have been documented.

Many of his investigations have taken place at Camp Guernsey where Reiss has been involved with a variety of activities, including Native American consultations.

"Dave has done his job with professionalism and passion," Col. Sheppard said. "But more than that, he has exhibited compassion. He realizes that others may have a differing point of view, and he can disagree with them without being disagreeable."

During the years, Reiss has proven to professionally handle a variety of cultural issues associated with Camp Guernsey, according to Garrison Commander Col. Steven Mount, which is admirable concerning that there are 17 Native American Tribes affiliated with the facility.

"Through his service, Mr. Reiss has greatly assisted the Wyoming Army National Guard in

complying with statutory responsibilities for the protection of the state’s cultural heritage while meeting the military mission in support of units and soldiers training at Camp Guernsey,” Construction and Facilities Management Officer Col. Tammy Maas said.

“I’ve never thought of my job as work,” Reiss said upon receiving the award. “I’ve always thought of the people I’ve dealt with and worked with as friends.”

Reiss was presented the award during a surprise ceremony at the Wyoming State Museum on June 14, 2007.

2007 WYOMING ARCHAEOLOGY MONTH PROCLAMATION

Governor Dave Freudenthal proclaimed September Wyoming Archaeology Awareness Month during a brief ceremony in his office Thursday.

Gov. Freudenthal was joined during the proclamation signing by members of the Wyoming State Historic Preservation Office, the Office of the Wyoming State Archaeologist, the Wyoming State Archives, the Wyoming Arts Council, the Univer-

sity of Wyoming Department of Anthropology, the U.S. Bureau of Land Management, the U.S. Forest Service, the Wyoming Department of Transportation, and the National Trust for Historic Preservation.

After signing the proclamation, Gov. Freudenthal was presented with this year’s Archaeology Awareness Month poster and a recent publication on Wyoming rock art entitled *Ancient Visions* authored by Julie Francis and Lawrence Loendorf. Dr. Frison, professor emeritus from the University of Wyoming, explained the significance of the Mummy Cave Site portrayed in this year’s poster to the governor.

The Wyoming Archaeology Awareness Month celebration will include the ninth annual George C. Frison Institute of Archaeology and Anthropology sponsored lecture, *People in High Places – Getting to and Living on the World’s High Plateaus*, by Dr. Mark Aldenderfer of the University of Arizona. The lecture will be held in the University of Wyoming Education Auditorium, Sept. 27 at 4 p.m. A reception will follow the lecture at 4:30 p.m. in the Anthropology Building.

The 2007 Wyoming Archaeology Awareness Month poster featuring Mummy Cave is available



free of charge. It may be picked up at the State Historic Preservation Office in Cheyenne in the Barrett Building, 2301 Central Ave., 3rd floor or in Laramie at the Education Annex Building, 13th and Lewis, 3rd floor, Room 351.

The posters are also available via mail with an \$8 charge to cover mailing costs. Limit one poster per person. Send your request along with a check or money order payable to "Wyoming Archaeology Month" and your name and mailing address to: Judy Wolf, State Historic Preservation Office, Wyoming Archaeology Month, Dept 3431, 1000 E. University Ave., Laramie WY 82071.

The 2007 WAAM t-shirts and coffee mugs are available at the State Museum Store in Cheyenne or via wyoshpo.state.wy.us/waamindx.htm. This year's design depicts a horse and rider based on a prehistoric petroglyph from a site in south-central Wyoming.

Short sleeve shirts are available at a cost of \$15. Shirts in sizes 2XL are available for an additional \$1.50. Long sleeve shirts are available for \$22. Add \$1.50 for size 2XL.

For the first time, ceramic coffee mugs, featuring the same horse and rider design, are available for \$12.95.

Proceeds from the sale of the t-shirts and mugs are used to help fund Wyoming Archaeology Awareness Month activities.

GOVERNOR'S PROCLAMATION

WHEREAS, Archaeology is the scientific study of sites and artifact assemblages in order to better understand the nature and patterns of past human behavior.

WHEREAS, Wyoming Archaeology Awareness Month connects the public with the state's cultural heritage through education outreach, which strengthens the important bond between past and present in the fabric of modern society.

WHEREAS, Archaeological sites, which were repeatedly occupied over long periods of time, often provide some of the most useful information about continuity and change in ancient ways of life.

WHEREAS, Wyoming Archaeology Awareness Month 2007 showcases the Mummy Cave Site located in the Absaroka Mountains between Cody and Yellowstone National Park. The rockshelter

contained deeply buried sediments that produced 38 distinct occupation levels found during excavations from 1963-1966.

WHEREAS, Mummy Cave provides 9,000 years of evidence for mountain occupation, informing scholars about high altitude adaptations and suggesting possible connections between prehistoric inhabitants and later Native American peoples.

WHEREAS, The site holds a prestigious position in the history of Wyoming Archaeology as a significant investigation by the Buffalo Bill Historical Center and the Smithsonian Institution that enlightened scholars about the lengthy sequence of human occupation in the Rocky Mountains.

NOW, THEREFORE, I, DAVE FREUDENTHAL, Governor of the State of Wyoming, do hereby proclaim September 2007 to be

"WYOMING ARCHAEOLOGY AWARENESS MONTH"

in Wyoming, and urge the people of Wyoming to take part in the activities planned to enhance public awareness of archaeology.

IN WITNESS WHEREOF, I have hereunto set my hand and caused the Executive Seal of the Governor of Wyoming to be affixed this ___ day of __ 2007.

Dave Freudenthal, Governor

**ANTHROPOLOGY DEPARTMENT
MOVES INTO NEW BUILDING ON
UNIVERSITY OF WYOMING CAMPUS**

In July, 2007, the Department of Anthropology moved into a new \$16 million dollar facility and held a ribbon-cutting ceremony on September 27. U.W. President Tom Buchanan and A&S Dean Oliver Walter attended, as well as some 300 alumni and UW faculty, staff, and students. The multiple ribbons were cut with hafted obsidian blades by several individuals, including visiting alumni, such as Dr. Dennis Stanford (Smithsonian Institution), represen-

tatives of the state and the Wyoming Archaeological Society, and Brigid Mulloy, daughter of William Mulloy, the department's founder. Coincidentally, the opening also marked the department's 40th anniversary.

The celebration included several talks by department alumni, who discussed their careers in anthropology. These included Elizabeth Cartright, Tom Ferguson, John Jameson, Joanne Mack, Dave McKee, Laura Scheiber, and Francis Smiley. They reminisced about the department's previous digs including that known as the "rat house" and George Frison's dirt-floored lab in the basement of the Arts and Sciences building. They also discussed the importance of Wyoming's role in their education. The opening coincided with the Frison Institute Board meeting, and so guests were

also treated to a lecture by Dr. Mark Aldenderfer (University of Arizona) on his research in Tibet. The state archaeologist's office displayed 10 years worth of their award-winning archaeology month posters. The Wind River Singers provided a drumming performance, and the human remains repository was blessed by Arapaho elders.

We're still getting settled in to the new facilities, but all agree that it marks a new era in the department's development. For those of you who live away from Wyoming, please stop by and ask us for a tour if you pass through town.

Robert Kelly
Anthropology Department Head



George Frison, Professor Emeritus and former Wyoming State Archaeologist, cutting one of the ribbons opening the new Anthropology Building with a hafted obsidian blade.

The new University of Wyoming Anthropology Building at the corner of 12th and Lewis, in Laramie, Wyoming.



PRESIDENT PIPES: ORIGIN AND DISTRIBUTION

by

**MICHAEL A. PFEIFFER, RICHARD T. GARTLEY,
AND J. BYRON SADBURY**

ABSTRACT

Anthropomorphic terra cotta tobacco pipe fragments have been found in historical archaeological sites across the United States. This paper will discuss the subset of these known widely as "President Pipes". This is actually a misnomer since some of these pipes are dedicated to presidential contenders. Several new points of origin for these pipes manufacture have been discovered. In addition to the anthropomorphic clay pipes, there are also anthropomorphic Meerschaum pipes and non anthropomorphic president and presidential contender commemorative pipes. A brief overview of the distribution of "President Pipes" and a summary of the relevant literature are presented.

INTRODUCTION

Short stemmed clay pipes in earth colors with various kinds of detachable stems have been referred to as stub stemmed, reed stemmed, terra cotta, Shaker, and "stum-melpfeifen". An intriguing subcategory of this group is the anthropomorphic, figural, or "face" pipe. Anthropomorphic clay tobacco pipe production began in America in the 18th Century. The subcategory of U.S. president pipes is intriguing due to their political nature, the fact that they are meant to represent specific people, and until recently, the question of where they were produced. These pipes have been recovered from archaeological sites across the country, ranging from small fragments to intact pipes. For decades, the source of a particular group of these pipes has been widely speculated upon since they had not been recovered from any of the known U.S. pipe factory sites or waster dumps. Although they are widely referred to as "President Pipes", it seems that they should more correctly be referred to as "Campaign Pipes". However, this nomenclature is not entirely suitable since some of these pipes, particularly for President Washington, are commemorative in nature. This paper will consist of a chronological review of the pertinent literature, the Ger-

man origin of some pipes, and illustrate examples of some President pipes. Some references to the known distribution of these pipes in the archaeological literature will be added. However, scouring the archaeological literature for one or two (frequently non-illustrated) fragments per report is far beyond the scope of this paper.

BACKGROUND AND CHRONOLOGICAL REVIEW OF THE PERTINENT LITERATURE

The first article to mention more than one or two examples of President pipes was Calver's article on Historical Clay Pipes (1931). Calver depicts six white ball clay pipes with integral stems: the Buchanan rebus¹ pipe (found in excavations in Central Park New York), full bust pipes of Lincoln, General Grant, Grover Cleveland, Benjamin Harrison and one with patriotic emblems on both sides said to be a memento of Lincoln's first campaign. He mentions that Barney Spring made pipes of the Buchanan type in 1856. However, Calver doubted that Spring made this specimen. He also details some of Spring's manufacturing history and locations. Calver does not illustrate any specimens of detachable stem tobacco pipes.

One of the earliest articles specifically on President pipes included a letter of inquiry by Bernard Fontana concerning clay pipe bowls from archaeological sites in southern Arizona (Painter and Fontana 1968). The four pipes he was seeking information on were a small center section of face, a nearly whole green glazed Washington pipe, an orange glazed Fillmore (he mentions an identical specimen from Ft. Vancouver, Washington), and a light orange Fr. Pierce stem. Painter attributed their most likely manufacture to the Akron Smoking Pipe Co. of Akron, Ohio.

In another article from 1968, Peter Shurke discusses Presidential Campaign pipes in his collection (Shurke 1968). The collection includes a white ball clay pipe with a likeness of Benjamin Harrison on the right side of the bowl with Eagle, shield & arrows on the left. He also illustrates a white ball clay Lincoln Emancipation

¹ A rebus is a message (sometimes a riddle) consisting of pictures representing syllables and words.

Originally presented at the 8th South Central Historical Archeology Conference Memphis, Tennessee 28 October 2006.

pipe with a green laurel wreath and a black child holding onto a black chain reclining against the back of his head above the stem. His Taft Pipe is made by Gambier of Paris and has a mold number of 1684. Shurke's other presidential pipes are included in the "Presidential Pipes of Other Materials" section.

In a single page article, Painter summarizes his information on President Pipes, mostly from information from Alan P. Owens of Norfolk, Virginia (Painter 1969:47). He lists the following pipes and probable makers:

Henry Clay – origin unknown;
William Henry Harrison – made in 1888 by Charles Kurth of Brooklyn, N.Y.;
Franklin Pierce – made in 1850s maker unknown;
Millard Fillmore – pipe made in Pennsylvania, maker unknown;
James Buchanan – made in 1856 by Barney Spring of Rochester, N.Y.;
Abraham Lincoln pipe – made in 1860 by Barney Spring;
Andrew Johnson – pipe made in 1864 – unknown possibly by Barney Spring;
Ulysses S. Grant – made in 1868 by Barney Spring of Rochester and Boston;
Peter Cooper – made in 1880 by A. Peyrau (NYC) [ran for office in 1876];
Grover Cleveland – pipe made in 1892 by Charles Kurth;
Williams Jennings Bryan – dated 1908 maker and origin unknown.

Painter mentions a set of "President" pipes made in the 1890s for the Smithsonian Institution from molds that Spring had used in preceding years. The specific type of Ulysses Grant pipe made is not discussed. It could have been a white ball clay pipe or one of the full head detachable stem styles.

Another article illustrates eight clay President pipes (Cousley 1972). White ball clay pipes with integral stem include Buchanan (with rebus for name), William McKinley, Benjamin Harrison (full head but stem broken off), and Grover Cleveland (anthropomorphic and face on the right side types). Pipes with detachable stems include the hexagonal Henry Clay, a brown Zachary Taylor, and a Millard Fillmore with obvious mold seam down the center of the face.

The article by Thomas is the first to specifically show the full bust head of a "philosopher" style and refer to it as a General Grant pipe. The style looks much more like the John Taber produced pipes than the known German examples. He mentions that it appears to match those illustrated in the Watkins book *Early*

New England Potters and Their Wares. While the Taber pipes have no names appearing on them (Thomas 1973)

"yet another is described as having 'General Grant' impressed on its stem. This example according to an article which appeared in American Country Antiques was the workmanship of one Barney Spring of Rochester, N.Y., and later of Boston. A set of Presidential bowls was produced and given to the Smithsonian in the 1890's from the original molds and dies Spring had used years before."

Thomas also illustrates the French firm Gambier's William Taft and William Jennings Bryan pipes, the white ball clay Buchanan "Rebus" Pipe, the white ball clay Lincoln pipe with an embossed bust on the front of the pipe, and the full head pipes of George Washington, Henry Clay, Zachary Taylor, Millard Fillmore, and Franklin Pierce (Thomas 1973).

In 1979, the ambitious task of documenting what was known about USA clay tobacco pipe production resulted in an illustrated survey and review article titled *Historic Clay Tobacco Pipemakers in the United States of America* (Sudbury 1979). This landmark study reported 19th Century President pipes made in New Hampshire, New York, Texas, and Virginia, but also recognized that President pipes and other anthropomorphic pipes of the same age and quality (Sudbury 1979: Plate 30) had been recovered in mid-19th century archaeological contexts whose place of manufacture was unknown.

Sullivan's short section on Political Pipes illustrates four political pipes, two wall-mount match holders and mentions several other political pipes (Sullivan 1980). The most unusual is from the 1880 campaign of Winfield Hancock. It is a clay pipe with a mustard color glaze with an open hand and a rooster above the stem and the junction of the stem and bowl. He also mentions the French made bust pipes from the 1900, 1904, and 1908 campaigns of William McKinley, William Jennings Bryan, Theodore Roosevelt, and William Howard Taft, all of which are marked "Gambier A Paris". He refers to the mold numbers as sequence numbers. Effigy pipes of both Roosevelts are depicted. Sullivan mentions that he knows of at least four bust designs for Teddy in clay, meerschaum, and briar, with and without his Rough Rider hat.

The definitive work on the John Taber and John Taber, Jr., clay tobacco pipe makers was published by S. Paul Jung, Jr. in 1996. John Taber Sr. probably made pipes in Alfred, Maine, from about 1840 to 1845 and in Wells, Maine, from about 1845 to 1860. John Taber Jr. was first listed as a tobacco pipe maker in 1850 in Rochester, New Hampshire. By 1851-53 he began manufacturing in

Wolfeboro in four different locations: Endicott Street-Wolfeboro, Beaver Brook – East Alton, The Taber Mill on Mink Brook – South Wolfeboro, and at The Pipe Shop on Mink Brook – South Wolfeboro. At Least 115 mold styles are known from these four locations and show a progression over time. Only a single bowl and bowl base with shank fragment are shown (Plate 4, No.13) from the Endicott location dating from 1853 to 1864. Jung refers to these as U.S. Grant pipes. He illustrates many more fragments from the later Beaver Brook (1864-1866) and Pipe Mill (1866-1882) locations. On page 24 he mentions that the U.S. Grant design duplicates a style made at Uslar and Grossalmerode, Germany, but that the pipes made by Taber are smaller.

O'Connor illustrates four clay pipes, two meerschau pipes, and a silver pipe (1997). He described one of the pipes as "This finely carved likeness of Woodrow Wilson is catalogued as being made of clay or chalk, but is more likely a meerschau." The pipe appears very similar in size and execution to the 1896 William Jennings Bryan also illustrated. He shows a tall ornate, short stemmed, clay pipe with a six sided bowl and a likeness of Henry Clay on the front panel. He attributes that to the period of Clay's candidacy but the style is of a very much later time frame, probably the 1890s. His last illustrated clay pipe is "A brown and gold painted ceramic pipe with a bamboo stem shows a proud Ulysses S. Grant, who served as president from 1869 to 1877." The pipe in the photocopied article has a shiny appearance as if it were glazed. It looks very similar to Uslar and Grossalmerode made pipes.

Gartley was the first to document the German manufacturing source for numerous President Pipes and other anthropomorphic pipes in the printed tobacco pipe literature (Gartley 2003). The other styles were referred to as Philosopher, Queen Victoria, Queen Louisa, Turk, Sphinx, and Hercules. One of the philosopher varieties may actually be a President Grant but there is no name on the pipe. In German, these are referred to as "Stummelpfeifen" or stub pipes. The two main manufacturing centers discussed are Uslar, in Lower Saxony, and Grossalmerode, in Hesse. These locations are 40 kilometers apart. Much of this material as it relates to President Pipes is presented in this current paper. Gartley also discusses American archaeological finds of long stemmed white clay pipes manufactured in Grossalmerode.

Gartley's interest in anthropomorphic pipes developed after participating in excavations in New Orleans, Louisiana, where several examples of this type of pipe were recovered. The sites tested were the Orange Street Cistern, dated 1845-1860, and the Annunciation St. Privy, dated 1850-1860; both sites are located in the "Irish Channel" area of the city (Gartley and Carskadden 1987).

In 2003, Sudbury updated his initial 1979 USA

pipemaker survey with a 251 slide Power Point presentation which included illustrations of 31 president pipes, including 19th Century specimens recovered from the Germany factories (Sudbury 2003a, 2003b). The <http://www.claypipes.com> web site includes a Grossalmerode-manufactured German face pipe in the masthead; this anthropomorphic pipe is not one of those under discussion in this paper but it does illustrate the classic green glaze in use in the 1850s (Sudbury 2002).

Bell's article is a short discussion of about 60 "face" pipes known to him (Bell 2004). Bell presents eight figures; the first seven show two different examples each of George Washington, Zachary Taylor, Millard Fillmore, Franklin Pierce, Lewis Cass, Henry Clay and Ulysses S. Grant. The last photo is a display case containing 66 clay anthropomorphic or effigy pipes (less than half are in the "President Pipes" category). Although the Grant pipes have no name stamped on them, Bell identifies them as Ulysses Grant pipes.

"Laura Watkins excavated a reddish-orange Grant pipe on the site of the John Taber Pottery which was in production from 1863-1872. President Grant won two terms, defeating Horatio Seymore in 1868 and Horace Greeley in 1872. This pipe appears to have been made and distributed from 1865 to 1870. There are at least three known molds of this pipe."(Bell 2004).

PRESIDENT OR CAMPAIGN PIPES MADE IN OTHER MATERIALS

Pipes commemorating Presidents have been made from other materials besides clay. A wooden effigy briar full bust relief of Teddy Roosevelt in his Rough Riders cap is illustrated by Shurke (1968). The maker's mark on this pipe is W.D.C (William Demuth & Company). The same article also shows a set of wooden "japanned" pipes issued during the campaign of 1876 with hand painted portraits. One pipe has the likenesses of Rutherford B. Hayes and his running mate William A. Wheeler. The other has the portraits of Samuel J. Tilden and his running mate Thomas A. Hendrick. Cousley (1972) shows a carved French briar in the likeness of John F. Kennedy and a Lincoln bust meerschau along with a mailing card with a miniature corn cob entitled "Little Mac". These tiny pipes were circulated during the brief boom for General Douglas MacArthur in 1952. Sullivan's short section on Political Pipes illustrates a Franklin Roosevelt briar pipe, which was produced in both large and small bowls, which are marked "Bruyere / Superieure / Made in France" (Sullivan 1980). Sullivan also has photographs of wall mount iron matchboxes from the 1872 campaign of Horace Greeley (in Quaker hat) and Ulysses Grant (with military cap). Rapaport's article discusses a rare collection of

Meerschaum pipes sculpted in the likeness of twenty-nine presidents from George Washington to Herbert Hoover (Rapaport 1994). The pipes were sculpted in Germany and the collection now resides in a private collection in Chicago. O'Connor's 1997 article includes a silver pipe smoked by Andrew Jackson, a meerschaum pipe in the likeness of Teddy Roosevelt, and a meerschaum pipe smoked by Ulysses Grant. Meerschaum pipes became very popular in the mid-1850s and helped to contribute to the demise of the clay pipe.

ORIGIN OF THE GERMAN PRESIDENT PIPES

German anthropomorphic reed-stem tobacco pipes, "stummelpfeifen", literally "stub pipes", of the mid 19th century are frequently found in archaeological excavations in the United States. They were specifically made for export to America and the German pipemakers believed they were for use by slaves living on cotton plantations; hence they were sometimes called "Sklavenpfeifen" (slave pipes) and "Negerpfeifen" (Negro pipes) (Anonymous n.d.b, Stephan 1995). But as will be seen in the discussion below, this notion is not supported by available archaeological evidence. Among the varieties of stummelpfeifen are portrayals of American presidents or other American political figures. This has led some American archaeologists to suggest that they are presidential campaign promotional items (c.f. Cresthull 1969:52). The general feeling among many American archaeologists has been that they were produced in the United States. (c.f. Sudbury 1979: Plate 30; Hudson et al. 1974:66, Figure 19) However, in Germany, the German origins of these pipes and their export to the United States are well known and well documented (Anonymous n.d.b, Seeliger 1993, Stephan 1995). Two towns in Germany about 40 km apart, Uslar in Lower Saxony and Grossalmerode in Hesse, are known to have been centers for the production of these pipes. President pipes produced at these German manufacturing sites include George Washington, Henry Clay, Zachary Taylor, Lewis Cass, Millard Fillmore, Franklin Pierce, and "Philosopher" (a.k.a. U.S. Grant). (Stephan 1995; Gartley 2003; Sudbury 2003.)

PIPE PRODUCTION IN USLAR

The Uslar municipal museum provided historical information about the pipe industry in Uslar (Anonymous n.d.b). The following summary is based on this information and Seeliger (1993). The manufacture of clay pipes in Uslar began in 1767 with the arrival of an experienced pipemaker from Neuweid. The first products were long-stemmed white clay pipes, with the production of this style continuing through the 19th century. Many of these pipes were modeled after the widely distributed pipes made at that time in Holland. Exports from Uslar to the USA and even to Holland began around the end of the

18th century. Peter W. Meseke, the son of the Uslar pipe-maker August Meseke, settled in the USA in 1836, and remained for about 20 years. While in the states, Meseke dealt in imported pipes from Uslar. During that period much of the pipe production in Uslar was specifically destined for the American market; in 1845 there were 4.5 million pipe bowls exported to the USA, principally to the southern states. The export trade peaked at 11 million pieces in 1866. The Stummelpfeifen portrayed American presidents in three-dimensions, for example George Washington and Franklin Pierce (Figure 1), or other likenesses, for example Henry Clay, Lewis Cass and "Turks"). They were glazed in various colors and made for smoking with a wooden stem. According to the information from the museum, the decline of the American business was triggered on one hand by the turmoil of the American Civil War, and on the other hand by the emergence of American pipe production. Moreover, the source of local pipe clay was exhausted, so that in the final years of the pipe business at Uslar the required clay had to be shipped from Grossalmerode. The last factory discontinued production in 1918.

PIPE PRODUCTION IN GROSSALMERODE

Archaeological finds place the beginning of white clay pipe production in Grossalmerode at around 1650. In approximately 1830 the production of "Stummelpfeifen" for export to the USA began. A son of the pipemaker Heinrich Goebel spent some time in America dealing in pipes from Grossalmerode. In 1845, Grossalmerode exported 13,412 hundredweights of pipes to America. Stephan calculates that this would amount to a minimum of 13.5 million pipes (Stephan 1995:66). Data for seven producers in the period 1864-1866 shows that 95% of their products were sold in the wholesale trade to America. During the 1860's, changes in the political situation in the USA were responsible for a major decrease in demand for German pipes and as a result, most pipemakers in Grossalmerode were out of business by 1872 with one working until 1915 (Seeliger 1993).

PERSONS REPRESENTED ON "STUMMELPFEIFEN" FOUND IN USLAR AND GROSSALMERODE

The German anthropomorphic pipes (Figures 2 and 3) have a white, tan or reddish earthenware body and can be either unglazed or glazed. The glazed pipes are found in one of several colors; red, red-brown, red-orange, orange, black, yellow, green, beige or brown. The possible use of pipe molds from the same supplier in both locations, and the documented use in Uslar of clay from Grossalmerode, presents problems in differentiating pipes made in the two locations. Stephan suggests that the green-glazed pipes were primarily made in Uslar



Figure 1: Uslar Museum catalog listing of Pierce pipes found at the Mesecke pipe factory in Uslar. Photo Courtesy of Dirk Rackwitz.

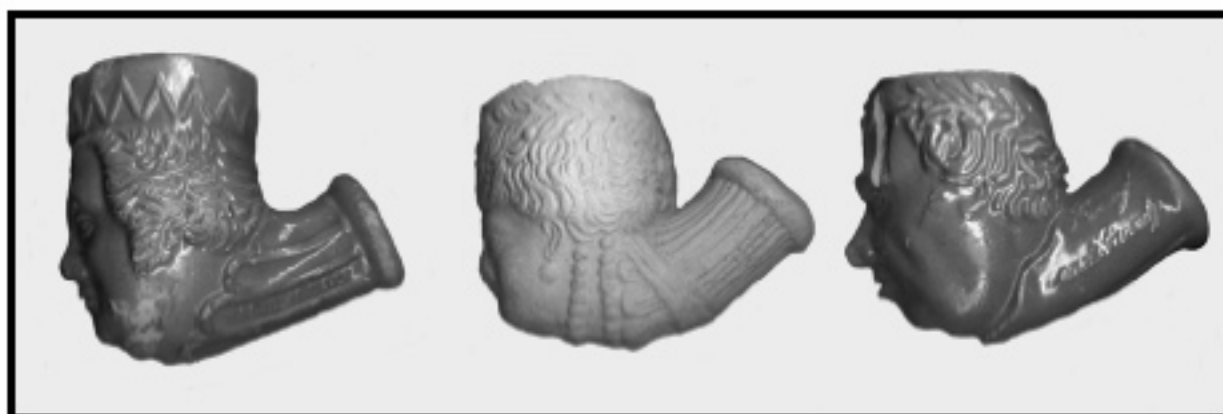

Figure 2: Pipes from the 1845-1860 New Orleans, Louisiana cistern. A. Red glazed marked "WASHINGTON". B. Red unglazed Victoria. C. Red glazed Taylor pipe marked in Script, "Rough and Ready".



Figure 3: Pipes from the 1850-1860 New Orleans cistern. A. Red glazed, unmarked Washington type. B. Unglazed, white, marked "HENRY CLAY". C. Red glazed, marked "PRES(IDENT)(FILL)MORE".

(Stephan 1995:186). The identifying names are those used by Stephan or found on manufacturer's price lists.

AMERICAN COPIES OF GERMAN "STUMMELPFEIFEN"

Some American pipe factories produced imitations of the imported German products. However, the American copies are quite crude compared to the originals.

Three unglazed pipes (Sudbury 1979:202, Plate 30) found at the Matthew Duncan pottery, which operated from 1856 to 1880 in Bastrop County, Texas, are rough copies of the German Zachary Taylor pipes. They exhibit all the design elements but not the fine details of the German pipes, suggesting that they were made in molds cast from a German original. Molds of original objects are known to result in "an inferior, weak and relatively undetailed facsimile of the original" (Anonymous n.d.c).

An unmarked, unglazed "philosopher" pipe with a tan body and a red slip was found in an 1850's privy in Baltimore, Maryland (Stilts, 2002, personal comm.). A gray glazed philosopher pipe with the same design features as the above was found in the Columbia River Gorge, Washington site, which was occupied from the 1820s to the 1880s (Minor, Rick et al 1979: Table 10-19, Fig 10-18 a-f; Pfeiffer 1989:Catalog 1-4,6-9). These specimens are very similar to those illustrated by Stephan (Stephan 1995:Figs. 220, 221, 223, 228, Plates 11 and 12.), but they lack the fine details of the hair and beard of the German examples (Figure 4). The John Taber pottery made these somewhat inferior copies of the German philosopher pipes in East Alton, New Hampshire (Sudbury 1979:170, 171, Plate 4-15) during the 1864-1872 period.

Two hundred examples of "Queen Victoria" pipes

were found at the Old Sacramento site in California. They were found in the previously mentioned building that burned in November 1852. The woman portrayed on the pipes had the curly hair and double bead necklaces of the German Victoria pipe; however the pipes had a yellow-brown glaze over a white clay body and were coarsely formed. It appears that no attempt was made to eliminate the mold lines. An obvious variance from the German pipes is that the angle between the shank and bowl is 90 degrees on the American pipes, whereas the angle on the German specimens is approximately 45 degrees. Crude Queen Louisa and Hercules pipes in the Doug Diez collection have the same body, glaze and stem angle as the above "Queen Victoria" pipes and are most likely products of the same maker. The source of these pipes is not known but the 90 degree angle between the bowl and shank suggests an American source.

Beginning in about 1850, factories in Point Pleasant, Ohio produced great numbers of pipes until the late 19th century (Sudbury 1979). These were widely distributed and are commonly found today; some styles occur on the same sites that have also yielded president pipes. The known products of these factories were stoneware reed-stem pipes. In fact, one type of pipe made in Point Pleasant, a Turk pipe, may have been inspired by the Turk pipes from Uslar and Grossalmerode (Stephan 1995:166). Again the angle between the stem and bowl is 90°, compared to the 45° angle on the German specimens.

SUMMARY OF GERMAN MANUFACTURE OF PRESIDENT PIPES

According to Seeliger, (1993:165), for Grossalmerode as well as Uslar, the most important ports where pipes entered North America were Baltimore, New York and New Orleans. Stephan (1995:166) states that most

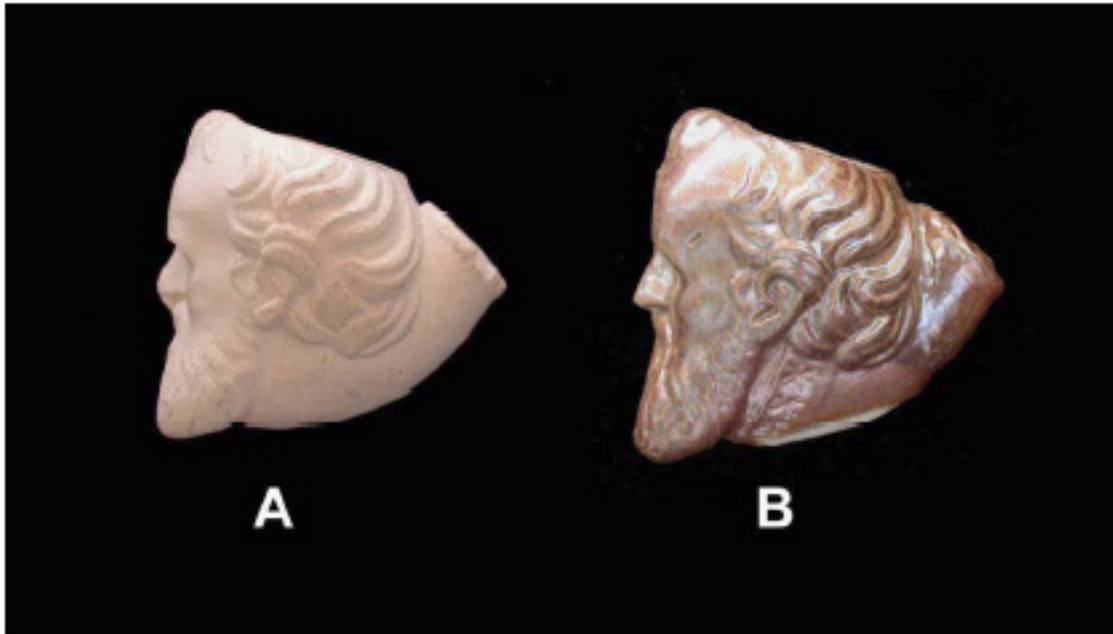

Figure 4: Contemporary pipes produced from the mold illustrated by Sudbury (1979:Pl. 64). A. White clay specimen. B. Stoneware version, including additional post-molding tooling.

of the pipes from Grossalmerode were shipped to New York, in addition to Baltimore and some other ports in the South. From these major ports the pipes would have readily been dispersed across America and that is confirmed in the archaeological discoveries. This distribution is consistent with the accounts from Uslar and Grossalmerode. However, the notion that slaves primarily used these pipes has not been confirmed in the reports examined by the authors. It is difficult to believe that slaveholders would have been purchasing imported pipes specifically for their slaves. In fact, only two of the pipes discussed so far were found on plantation sites. However, a search of available reports of archaeological excavations of southern plantations has turned up an additional example. A badly damaged green-glazed pipe similar to the German pipes bears an image of an unidentifiable person. This pipe was among 2000 white clay pipes found at the Dog River Plantation site in Alabama (Waselkov 2002). This plantation was abandoned by the end of the American Civil War (1865).

Pipes representing two presidents, Taylor and Fillmore, should also be included in the pipe variety listings for Uslar and Grossalmerode. The Taylor pipe most likely dates to his term as president (1849-50), and would represent the earliest known of the presidential series of pipes. Henry Clay may be the earliest in the series. The German-produced presidential series apparently ends with Franklin Pierce. If as reported, pipes were being exported to the US by the millions up to and including 1866, it is interesting that there are no known German reed stem

pipes depicting James Buchanan (president 1857-1861) or Abraham Lincoln (president 1861-1865).

Contemporary German documents dating to about the end of the American Civil War show that the pipemakers of Grossalmerode were concerned with the decrease in sales to America. One apparent reason for the drop was that American tariffs had been substantially raised during the war, making German pipes more expensive. The higher tariffs encouraged increased production in the US and new factories had been established here (Stephan 1995:135). Among Grossalmerode's American competitors in the mid-nineteenth century would have been the pipe factory at Point Pleasant, Ohio, the John Taber potteries in Maine and in New Hampshire, the extensive pipe production center in Akron, Ohio, and possibly the pipe industry of Pamplin, Virginia, which all produced large quantities of reed-stem pipes. During the period ca. 1847-1890 the Merrill pottery in Akron, Ohio also made reed-stem pipes. In 1847 the Merrill's of Akron, Ohio, had invented and patented pipe making machinery; the Merrills reported that they produced 280,000 pipes in 1850 (Sudbury 1979:184). A stoneware anthropomorphic pipe, variously suggested to represent Thomas Jefferson or Jefferson Davis, has also been reported (Sudbury 1979: Plate 57). An apparently Civil War vintage stub stem anthropomorphic brass pipe mold of this same basic style has been reported (Sudbury 1979:Plate 64) and has recently been used to product "counterfeit" pipes for sale (Figure 4). This mold and the "Jefferson" pipe are the same basic form as the Lincoln pipe illustrated in Figure

16. The pipe in Figure 4 may represent the image of Robert E. Lee.

(Painter and Fontana 1968:161, 162).

**KNOWN EXAMPLES OF CLAY
PRESIDENT PIPES**

George Washington 1789-1797

[Pipe actually produced mid-19th century]

Washington clay tobacco pipes (Figure 5) are thought to be primarily commemorative in nature since none are known to date from either his presidential campaigns or period in office. Washington wears a crown with an encircling band of V's. The shank is sometimes marked "WASHINGTON" in capital letters on the left side (Stephan 1995: Figs. 223, 224, 228 and Plate 12).

A red-brown glazed George Washington pipe, marked "WASHINGTON" was found in the 1845-1860 level Orange Street cistern (Figure 2a). It appears to be identical to the Washington pipes confirmed to be from Grossalmerode (Stephan 1995:Figs. 223, 224, 228, Plate 12). An unmarked Washington red glazed pipe with a different image came from the Annunciation Street privy (Figure 3a). Stephan does not illustrate a similar pipe and if not for an example in the Doug Diez collection marked "WASHINGTON", it would be a stretch to call this a Washington pipe. A bowl fragment bearing the typical crown of the Washington pipes was found at the Desoto, Nebraska Townsite Site (25-WN-16) dated to 1855-1875 (Pfeiffer 1982:189, Fig. 29j, 2006:88). A fragment of a probable Washington pipe with an orange body and a clear glaze was found in excavations at the Hudson's Bay Company's Bellevue Farm, San Juan Island, Washington which was occupied from 1853 to about 1870 (Pfeiffer 1983:161, 165, 168, Figs. 1e and 2e). A green-glazed marked example was reported from a site in Arizona dated to the second half of the 19th century

Henry Clay

Lost three Presidential elections (1824 as Democratic Republican; 1832 as a National Republican; 1844 as a Whig)

Henry Clay was a prominent American politician in the 1803-1852 period. A laurel wreath encircles his head and the shank is marked in capital letters, "HENRY" on the left side and "CLAY" on the right side (Stephan 1995: Fig. 225).

Among the three pipes found in the 1850-1860 Annunciation Street privy, located in the same city block as the previously discussed New Orleans cistern, was a white clay pipe marked "HENRY on the left side of the shank and "CLAY" on the right side of the shank (Figure 3b). This pipe is similar to the Henry Clay pipes illustrated from Grossalmerode (Stephan Figure 225) and may be a Grossalmerode product. There is also the tall clay pipe with a six sided bowl often referred to as a German "Coffeehouse" style (Figures 7, 8) (O'Connor 1997:58). This would have had a long stem and mouthpiece. The Henry Clay and other earlier styles of this pipe, usually with no country of origin making, are marked "WARRANTED TO COLOR" on the shank or above the head. According to their ca. 1915 product catalog, the American Clay Pipe Works of Brooklyn, New York catalog was manufacturing Henry Clay pipes (Jung 1988:11). Meerschaum pipes started becoming popular and widely distributed in the mid-1850s and they are valued more as they begin to color from smoking. This may have been an attempt to collate the wonderful smoking qualities of meerschaum with the more humble clay. Most known examples of this style with a known country of origin are marked "Austria" and



Figure 5: George Washington pipes recovered in the USA. A. Clear glaze over red clay, unmarked. B. White clay, unglazed; marked "WASH..." on the left stem.

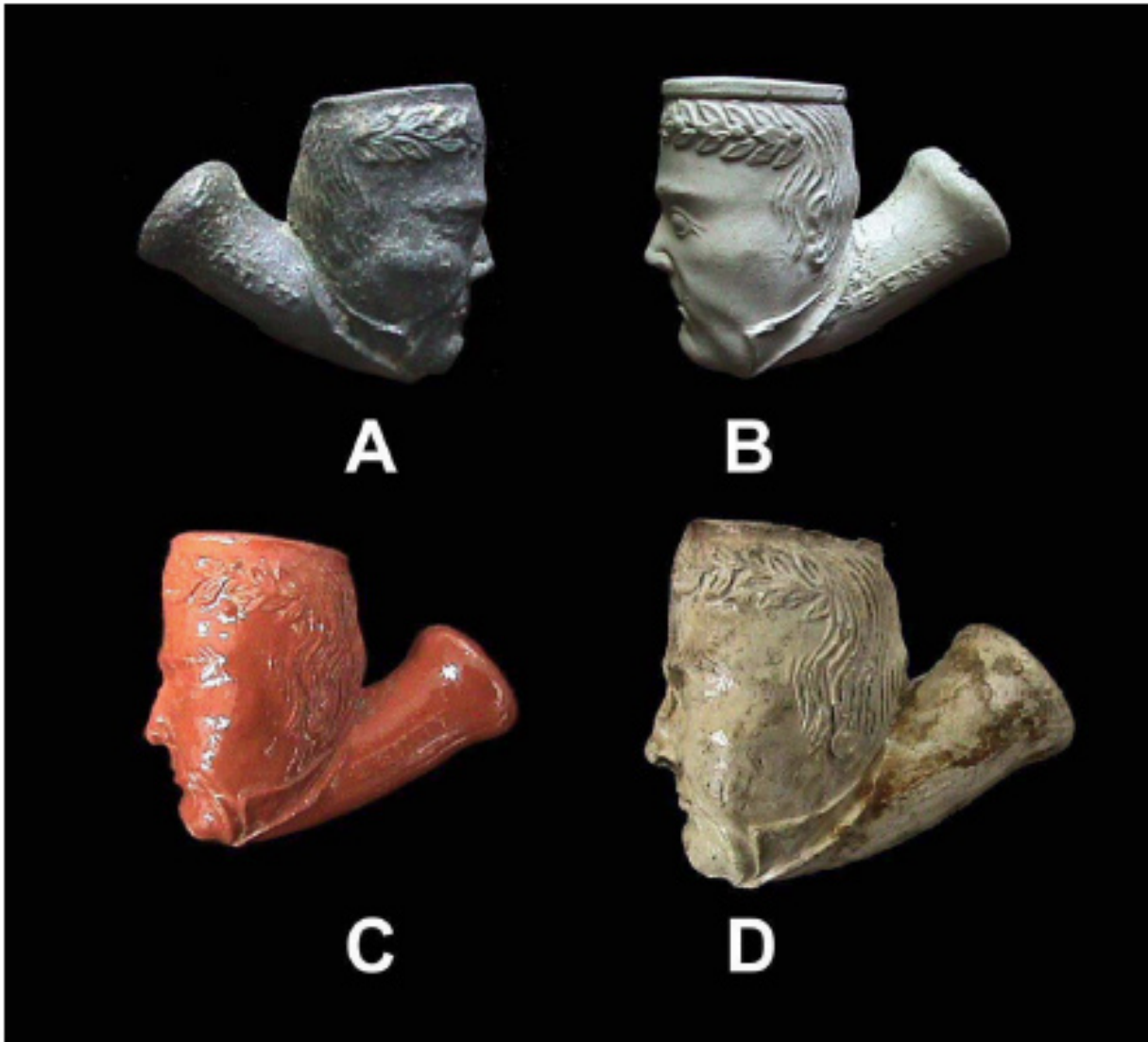

Figure 6: Henry Clay stub stemmed pipes, manufactured in Germany and found in the USA. Specimen C was found in an Illinois privy. [Scale of these photographs varies.]

may have been made post 1891 McKinley Tariff Act.

Zachary Taylor: 1849-1850

Taylor is depicted wearing a laurel wreath similar to those worn by some of the other political figures in this series of pipes. Zachary Taylor, who was President 1849-50, was nicknamed "Old Rough and Ready." These pipes were usually, but not always, marked. When marked, the legend "Rough and Ready" appears on the left side of the shank in either script or block letters. Stephan does not identify Taylor pipes as products of Grossalmerode. However he illustrates but doesn't comment upon an apparently unmarked pipe that seems to be identical to an unmarked Taylor pipe found in Pennsylvania (Stephan 1995: Plate 224).

A red-brown glazed pipe from the Orange Street cistern in New Orleans, is marked in script on the left side of the shank with the legend "Rough and Ready" (Figure 2C). Wilson (1971:Fig. 36C) illustrates a marked green glazed Rough and Ready pipe from Fort Sanders, Wyoming. The marked shank of a red-brown "Rough and Ready" pipe was found during the excavations at the James Langworthy site in Dubuque, Iowa. The house was occupied from the 1830's to 1974 and the context of the pipe was not dated with any precision (Perry n.d.:5). A red glazed pipe marked "ROUGH AND READY" in upper case block letters was found at Fort Johnson South Carolina (Steen 2002:736). A similar pipe of unknown provenience is shown (Figure 9B).

An unglazed unmarked Zachary Taylor pipe was



Figure 7: Henry Clay Pipe in “Coffeehouse Style” pipe, marked “HENRY CLAY” above bust.

excavated from a privy dating to the 1850’s in State College, Pennsylvania (Stilts, 2002, personal comm.).

Lewis Cass

Lost 1848 election to Taylor

(US Secretary of State 1848, 1857-1860). A laurel wreath encircles his head and the shank is marked in capital letters “LOUIS” on the left and “CASS” on the right (Figure 10) (Stephan 1995:Figs. 224, 225, 228 and Plate 12). A green-glazed pipe marked “LEWIS CASS” was found at Fort Sanders, Wyoming (Wilson 1971:49, Fig. 36E). Another marked “LEWIS CASS” pipe is reported from Bexar County, Texas (Hudson et al 1974:66, Figure 19). A pipe marked “LEWIS CASS” was found in a Harrison, Ohio privy dating from 1860-1880 (Anonymous n.d.a). These all appear to be identical to the documented German Cass pipes.

Millard Fillmore: 1850-1853

Fillmore is shown wearing a laurel wreath similar to those shown on the Henry Clay and Lewis Cass pipes. All examples seen are marked “PRESIDENT” on the left side of the shank and “FILLMORE” on the right (Figure 11). Although this type of pipe is assuredly a product of Uslar or Grossalmerode, Fillmore is not listed among the presidents on pipes recorded as made in Uslar and Grossalmerode. However the pipes have the same style, paste and superior quality as the other German presiden-



Figure 8: Henry Clay Pipe produced by the American Clay Pipe Works, Incorporated; stem cork still present. Left side. B. “WARRANTED TO COLOR” on right shank.

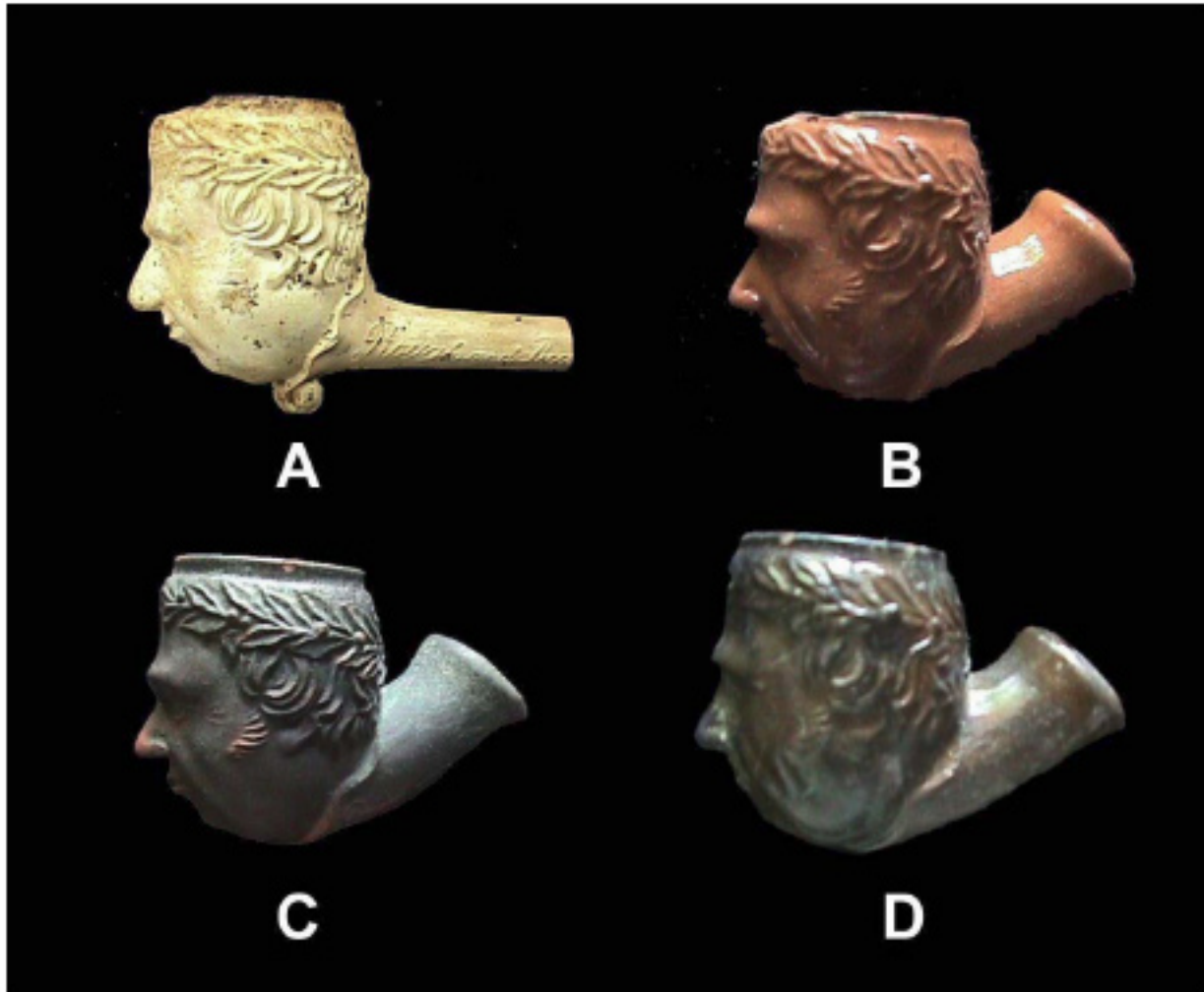

Figure 9: Zachary Taylor (“Rough and Ready”) Pipes. A. Ball clay specimen, “Rough and Ready” on left side of stem (NYC). The ca. 1850 German mold for this pipe is illustrated by Stephan (1995:133). B. Red glaze on red clay, unmarked. C. Grey clay, unglazed, unmarked. D. Grey clay, glazed, unmarked.

tial pipes. Specimens of this pipe were observed in the collections of German workers who had excavated at the manufacturing sites (Sudbury, personal observation).

Franklin Pierce: 1853-1857

Examples from Grossalmerode are marked in capital letters, “FR. PIERCE” on the left side of the shank and “PRESIDENT” on the right side (Figures 12, 13 and 14), and a band of stars encircles the shank near the base of the bowl (Stephan 1995:Figs. 225, 227 and Plate 12). Seeliger (1993:146) illustrates a similar pipe from Uslar but it is marked “FRANK PIERCE” on the left side of the shank and “PRESIDENT” on the right side. It also lacks the band of stars found on the Grossalmerode examples.

A clear-glazed pipe with a slip on a tan body, marked “FR. PIERCE” on the left side of the shank and

“PRESIDENT” on the right side of the shank was found in excavations at the Hudson’s Bay Company’s Bellevue Farm, San Juan Island, Washington (Pfeiffer 1983:161, 165, 168, Figs. 1e and 2e). An unglazed orange pipe with the above markings is reported from an 1850-1900 site in Arizona (Painter and Fontana 1976:161,162). These pipes have a band of stars encircling the front end of the shank and match in every detail the Pierce pipes illustrated by Stephan (1995; Figs. 224-227). Wilson illustrates another variety of Pierce pipe from Fort Sanders, Wyoming, which was occupied from 1866-1882. (1971: 48, Fig. 36A). This red-bodied clear-glazed pipe is described as having the name “FRANKLIN PIERCE” on the left side of the shank and “PRESIDENT” on the right, with the letters “C.P.” below “PRESIDENT”. This pipe lacks a band of stars and this variant is not evident in the Pierce pipes illustrated by Stephan (1995).

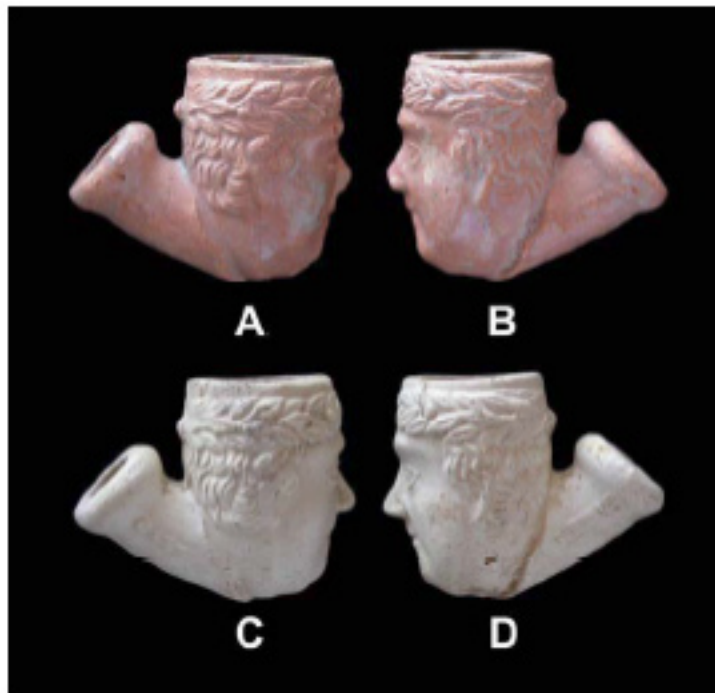

Figure 10: Lewis Cass pipes made in Germany. A, B. Red clay, glazed. C, D. White clay, unglazed. A, C. Marked CASS on the stem. B, D. Marked LEWIS on the stem.



Figure 11: Millard Fillmore pipes. A. Red glaze over red clay. B. White clay, unglazed.

James Buchanan: 1857-1861

Buchanan was elected five times to the House of Representatives; then, after an interlude as Minister to Russia, served for a decade in the Senate. He became Polk’s Secretary of State and Pierce’s Minister to Great Britain. Service abroad helped to bring him the Demo-

cratic nomination in 1856 because it had exempted him from involvement in bitter domestic controversies. (White House 2006)

This is a white ball clay pipe with integral stem (Figure 15). The bowl has an embossed rebus consisting of a buck on the right side and a cannon on the left side. Painter’s informant, Alan P. Owens (1969), attributes the



Figure 12: Unglazed white pipe marked “FRANK PIERCE”, identical to pipes found at the Meseke Factory in Uslar. Unknown provenience, John Stilts collection.



Figure 13: Green-glazed pipe marked “FR PIERCE”, with a band of stars around the shank, identical to pipes found in Grossalm-erode. Unknown provenience, John Stilts collection.

manufacture to Barney Spring of Rochester, N.Y. Owens also attributes other pipes, now known to be made by others, to that manufacturer.

Abraham Lincoln 1861-1865

Lincoln was assassinated shortly into his second term. These pipes may be commemorative in nature and not from a political campaign (Figure 16). Makers are unknown.

The broken stoneware pipe on the left includes the classical laurel wreath motif similar to those on the Henry Clay, Zachary Taylor, Lewis Cass, and Millard Fillmore pipes. [Note stylistic similarities to the modern pipe in Figure 4, and the mold reported previously (Sudbury

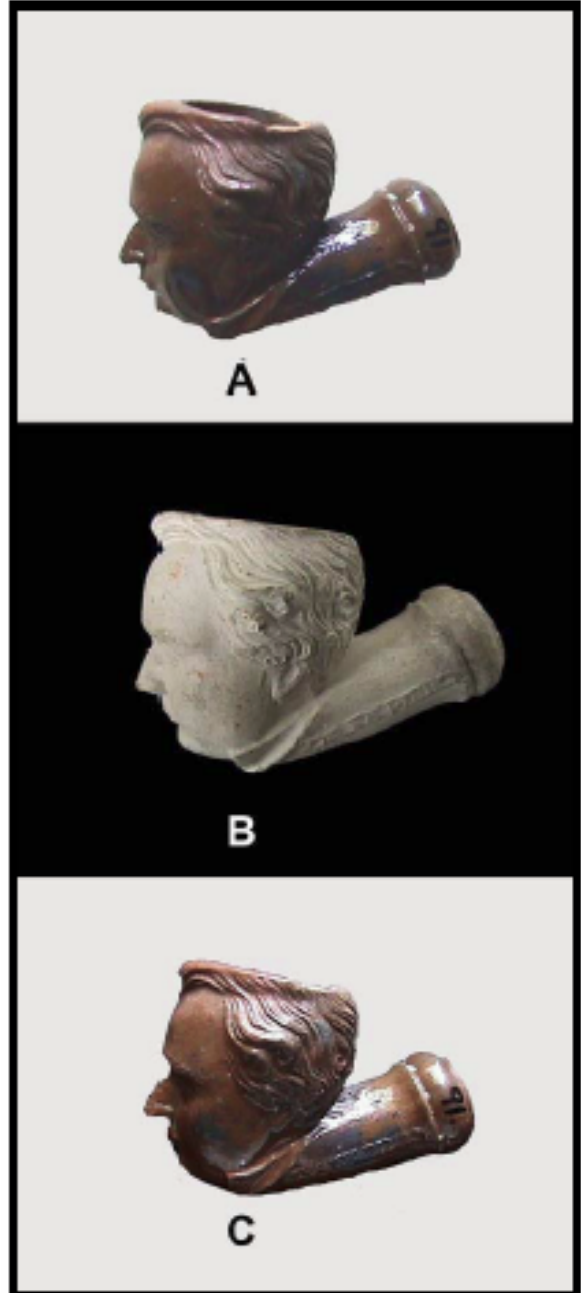

Figure 14: Franklin Pierce pipes. A. Glazed, red clay. B. White clay, unglazed. C. Glazed, red clay.

1979: Plate 64)].

Ulysses S. Grant: 1869-1877

The German catalogs refer to this style as the “Philosopher” pipe. The German manufactured pipes have the best appearance and are most clearly molded (Figure 17 and 18). A fragment of this style from the earlier Taber location at Endicott Street, from 1853 to 1864, dates be-

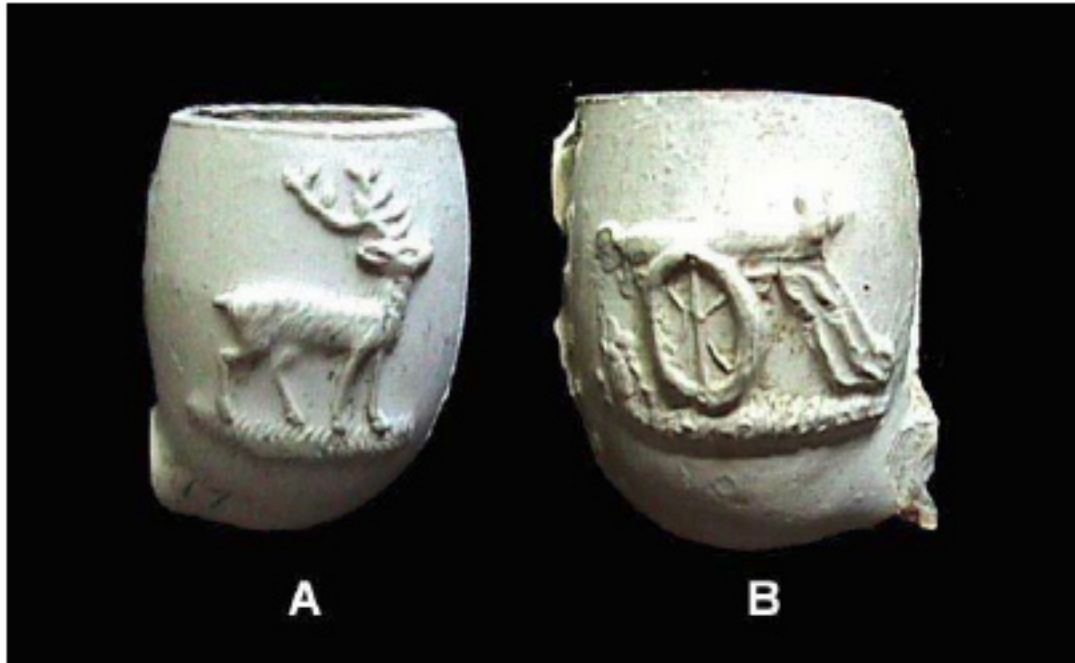

Figure 15: Buchanan rebus pipe (manufacturer uncertain).



Figure 16: Lincoln Pipes. A. Stoneware Lincoln pipe; probable USA manufacture. B. White Clay Lincoln pipe, probable European manufacture.

for the period of Grant’s popularity in the North. Ulysses Grant was widely known from his Civil War military campaigns as early as 1864. The Taber pipes were made at the Beaver Brook location, in East Alton, from 1864-1866. The American copies of the German “philosopher” pipe, as well as the original German import, may have been marketed as a “Ulysses Grant” pipe.

One definite U.S. Grant clay pipe is shown in O’Connor (1997:60). “A brown and gold painted ceramic

pipe with a bamboo stem shows a proud Ulysses S. Grant, who served as president from 1869 to 1877.” The pipe in the photocopied article has a shiny appearance as if it were glazed. It looks very similar to Uslar and Grossalm-erode made pipes. The German made “philosopher” pipes have often been called a “U.S. Grant” pipe in America by antiquarians and some pipe collectors. The American copies of the German “philosopher” pipe are referred to “Grant” pipes by Paul Jung. Most of the Taber pipes ap-



Figure 17: German manufactured Grant pipes found in the USA. A. Red glazed, red clay. B, C. Unglazed.

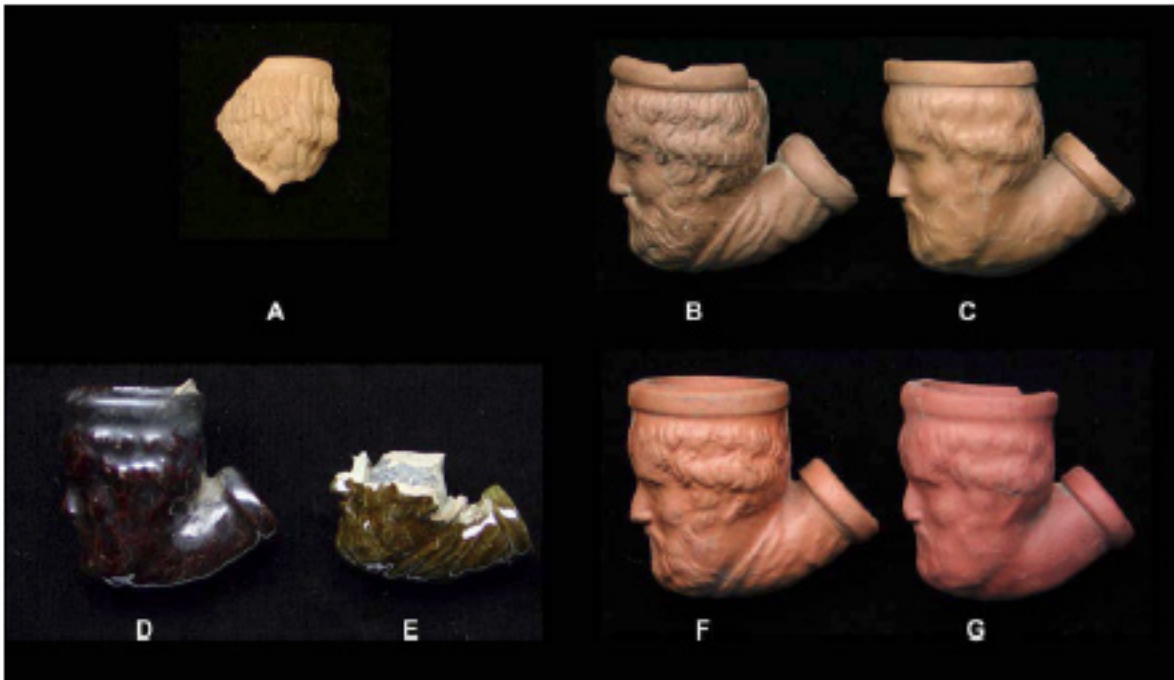

Figure 18: Taber pipes in the likeness of President U.S. Grant. A. Taber Endicott Street, Wolfeboro 1853-1864. B, C. Taber Beaver Brook, East Alton 1864-1866. D-G. Taber Pipe Mill, South Wolfeboro 1866-1882.

pear to date from his time of popularity during the civil war to his presidency.

Benjamin Harrison: 1889-1893

Benjamin was the Grandson of President William Henry Harrison (Figure 19). In the 1880's he served in the United States Senate where he championed Indians, homesteaders, and Civil War veterans. In the Presidential election, Harrison received 100,000 fewer popular votes than Cleveland, but carried the Electoral College 233 to 168. He was defeated in the 1892 election by Grover

Cleveland.

A white ball clay stemmed pipe is illustrated in Shurke (1968:52). He also mentions a similar pipe with the likeness of Grover Cleveland from the 1888 campaign.

William McKinley: 1897-1901

McKinley's term is most noted for the 100 day Spanish-American War in which the U.S. destroyed the Spanish fleet in Santiago Harbor, and annexed Guam, the Philippines, and Puerto Rico. In 1900, McKinley cam-

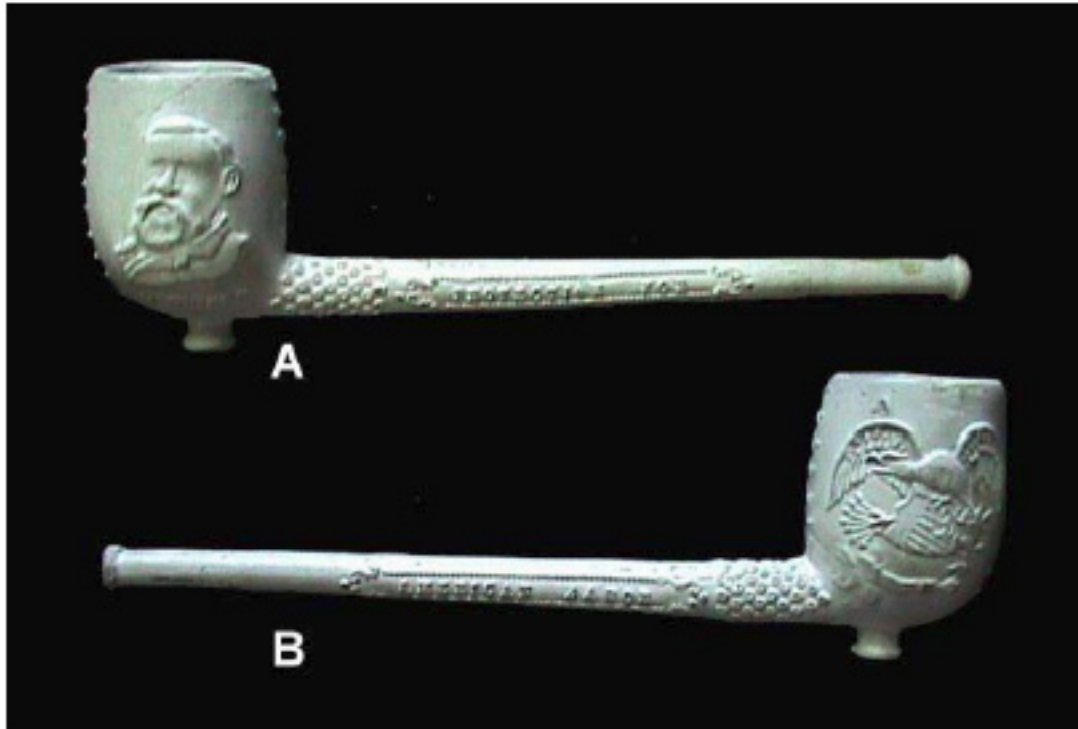

Figure 19: Benjamin Harrison pipe (both sides illustrated). A. Bust; stem reads: "PROTECTION FOR." B. Eagle with shield and arrows; stem reads "AMERICAN LABOR."

paigned against Bryan. While Bryan inveighed against imperialism, McKinley quietly stood for "the full dinner pail." His second term, which had begun auspiciously, came to a tragic end in September 1901. He was standing in a receiving line at the Buffalo Pan-American Exposition when a deranged anarchist shot him twice. He died eight days later. (White House 2006)

In addition to the four colors illustrated (Figure 20), there is an obvious difference in the height of the head. There must have been at least two different molds from this manufacturer. A full bust pipe was made by Gambier of Paris.

William Jennings Bryan

Bryan lost the presidential election to McKinley in 1896 and 1900 and again to Taft in 1908 (Figure 21).

Sullivan (1980:153) mentions a series of four highly detailed bust figural pipes by Gambier of Paris for the elections of 1900, 1904 and 1908. They depict William McKinley, William Jennings Bryan, Theodore Roosevelt and William Howard Taft. Since the Gambier mold number for Bryan is 1683 and that of Taft is 1684, these two pipes may date from the 1908 Campaign.

Theodore Roosevelt: 1901-1909

With the assassination of President McKinley, Theodore Roosevelt (Figure 22) became the youngest United States President at age 42. Although only elected

to a single term, he could have run for another full term. However, Roosevelt considered that his almost eight years was enough and retired. He made another run for the presidency in 1912.

William H. Taft: 1909-1913

William Taft (Figure 23) was the hand picked successor to Theodore Roosevelt. Taft alienated many liberal Republicans who later formed the Progressive Party. The Republicans re-nominated Taft in 1912. Roosevelt then bolted the party to lead the Progressives. Having a split party guaranteed the election of Woodrow Wilson.

Richard M. Nixon: 1969-1974

Richard Nixon (Figure 24) was elected by a painfully divided nation with turbulence in the cities and war overseas. In 1972 he was re-elected over democratic candidate George McGovern by one of the widest margins on record. Within a few months, his administration was embroiled in the "Watergate" scandal. He resigned from office in August 1974.

QUESTIONS FOR FUTURE RESEARCH

One of the more interesting phenomena noticed during the research for this paper has been the nomenclature for the German "philosopher" or the American "U.S. Grant" anthropomorphic pipes. Were the American "Grant" pipes first copied from the German "philosopher"

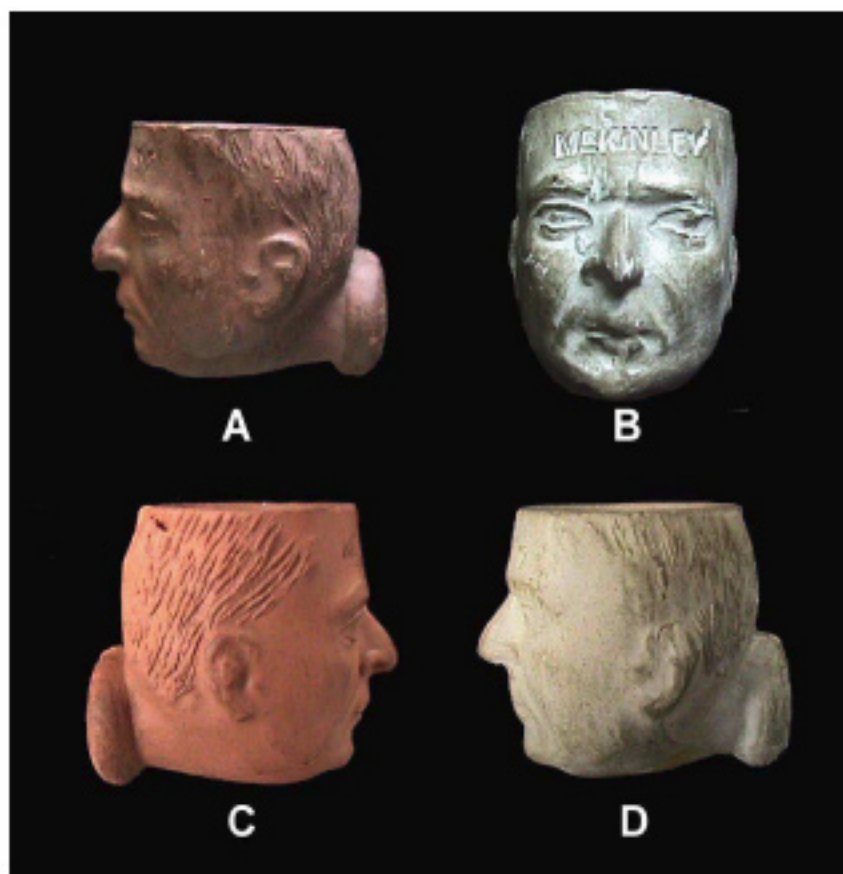

Figure 20: McKinley pipes, probably American-made. All four specimens have the name imprinted on the forehead (see B). A. Red/pink clay. B, D. White clay. C. Orange clay.



Figure 21: Bryan pipe marked "GAMBIER A PARIS." Mold Number 1683.

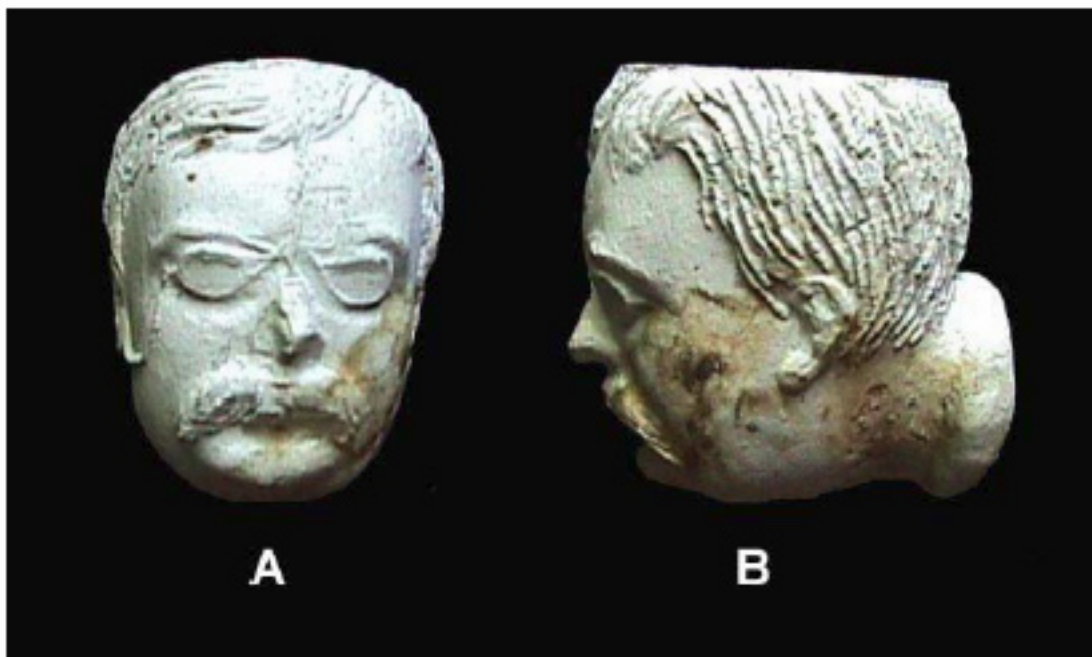

Figure 22: This style of pipe is very similar to that of the McKinley pipes [Figure 20]. These pipes were probably made by the same manufacturer. [A full bust pipe of Roosevelt was made by Gambier of Paris.]



Figure 23: TAFT pipe made by “GAMBIER A PARIS.” Mold Number 1684.

pipes and then had the “U.S. Grant” attributed to them at a later date? Were the German “philosopher” pipes ever marketed in America as “Grant” pipes? Were they ever manufactured in Germany as “Grant” pipes? Is the “Grant” pipe in O’Connor (1997:60) actually produced in the Uslar / Grossalmerode area? How many clay tobacco pipe representations of American presidents remain to be documented? How many of the white ball clay pipes from

James Buchanan through Theodore Roosevelt were made by Barney Spring? Spring’s production is insufficiently documented. The four illustrated examples of William McKinley pipes demonstrate at least two molds. These are different from any of the other styles so who made these pipes? In the days of the telegraph and newspapers as the primary means of information, were these pipes really passed out as we would pass out campaign buttons



Figure 24: This porcelain-like pipe appears to be a caricature pipe rather than a campaign, victory or commemorative vein since it emphasizes the jowls and nose. Maker unknown.

or were they given to specific supporters? Why are some major German export pipe styles never mentioned in the German literature?

CONCLUSIONS

The category of “President Pipes” might better be referred to as “Political Pipes” since some, like the German produced George Washington, are commemorative in nature, some are caricatures or novelties, and some represent the campaigns of the contenders as well as the winners. The German production appears to be concentrated from 1844 (Henry Clay’s last attempt) thru 1852 (Franklin Pierce’s first election). The production of “philosopher” copies or U.S. Grant pipes by John Taber is from the early 1850s thru the early 1880s. White ball clay pipes with an integral stem have been made from the time of Benjamin Harrison thru Theodore Roosevelt but their manufacturing source and history is not well documented. Gambier of Paris made full bust pipes for the elections of 1900, 1904 and 1908. They depict William McKinley, William Jennings Bryan, Theodore Roosevelt and William Howard Taft. The phenomenon of Political Pipes appears to be centered in the time period of the mid-1840s thru the first decade of the 1900s.

ACKNOWLEDGEMENTS

We thank Doug Diez for photographs of pipes in his collection, Dirk Rackwitz of Stadverwaltung Uslar for supplying information about the pipe industry in Uslar, John Stilts for supplying pictures of pipes in his collection, and Jeff Carskadden of the Muskingum Valley Archaeological Survey for his comments and suggestions.

S. Paul Jung, Jr. supplied the photographs in Figure 18. Ben Rapaport and Gene Umberger graciously supplied background material and references.

REFERENCES CITED

- Anonymous
n.d.a *Hams Burgers*. <http://hometown.aol.com/artifact/july21.html>. 2002
- Anonymous
n.d.b Die Uslare Pfeifenbaeckerei. Manuscript on file in the Museum Uslar, Uslar, Germany.
- Anonymous
n.d.c *Antique Timepieces*. <http://www.timepieces.com/jewelry.html>.
- Bell, Max
2004 Collecting American Face Pipes. *Bottles and Extras* pp. 52-54. Spring.
- Calver, William L.
1931 Historical Clay Pipes. *New York Historical Society Quarterly Bulletin* 14(3): 91-102. [This was one of a series of articles later republished after Calver’s death (1940) in: Calver, William Louis and Reginald P. Bolton. *History Written With Pick and Shovel*. New York Historical Society, New York, NY, 1950, pp. 280-291.]
- Cousley, Sam A.
1972 Presidential Clay Pipes. *Antiques Journal* 27(11):24-26.
- Gartley, Richard T.
2003 Deutsche “Stummelpfeifen” von Aus-

- grabungen in den USA. *Knasterkopf* 16:180-189.
- Gartley, Richard, and Jeff Carskadden
 1987 Marbles from an Irish Channel Cistern, New Orleans, Louisiana. *Proceedings of the Symposium on Ohio Valley Urban and Historic Archaeology* 5:12-125.
- Hudson, William R., Jr., Warren M. Lynn, and Dan Scurlock.
 1974 Walker Ranch An Archeological Reconnaissance and Excavations in Northern Bexar County, Texas. *Office of the State Archeologist Reports Number 26*. Texas Historical Commission, Austin.
- Humphrey, Richard V.
 1969 Clay Pipes From Old Sacramento. *Historical Archaeology* 3:12-33.
- Jung, S. Paul, Jr.
 1988 *American Clay Pipe Works Incorporated*. [ca. 1915 catalog reprint with accompanying company history.] Privately printed, Bel Air, Maryland.
 1996 *John Taber and John Taber Jr.: Two New England Clay Tobacco Pipe Makers. A Family History and Illustrated Catalogue*. Privately Published, Bel Air, Maryland.
- O'Connor, Larry
 1997 Presidential Pipes. *Pipes & Tobacco* pp. 56, 58, 60, 62. Fall.
- Painter, Floyd
 1969 President Pipes – A Summary. *The Chesapeake* 7(2):47. April.
- Painter, Floyd, and Bernard B. Fontana
 1968 “President Pipes” from Arizona. *The Chesapeake* 6(6):160-161. December.
- Perry, Michael V.
 n.d. A *Territorial Period Site in Dubuque*. Office of the State Archaeologist, The University of Iowa, Iowa City, Iowa. <http://www.uiowa.edu/~osa/learn/dubuque/tps1.htm>
- Pfeiffer, Michael A.
 1981a Clay Tobacco Pipes From Spokane House and Fort Colville. *Northwest Anthropological Research Notes* 15(2):221-235.
 1981b Notes on Unusual Clay Tobacco Pipes Found in Seattle. *Historical Archaeology* 15(2):109-112.
 1982a The Clay Pipes. In: Kanaka Village/Vancouver Barracks, 1975. *Reports in Highway Archaeology* No. 7:113-127. Office of Public Archaeology, Institute of Environmental Studies, University of Washington, Seattle.
- 1982b *Clay Tobacco Pipes and the Fur Trade of the Pacific Northwest and Northern Plains*. M.A. Thesis, Department of Sociology and Anthropology, University of Idaho, Moscow.
- 1983a Clay Tobacco Pipes from Hudson’s Bay Company’s Bellevue Farm, San Juan Island, Washington (45-SJ-295). In: *The Archaeology of the Clay Tobacco Pipe VIII. America. British Archaeological Reports, International Series* 175:162-183.
- 1983b The Tobacco-Related Artifact Assemblage from the Martinez Adobe, Pinole, California. In: *The Archaeology of the Clay Tobacco Pipe VIII. America. British Archaeological Reports, International Series* 175:185-194.
- 1983c Clay Tobacco Pipes From Five Archaeological Sites in Nebraska. *Historic Clay Tobacco Pipe Studies* 2:39-47.
- 1989 Curation Manual for the Archaeological Collection from 45SA11, North Bonneville, Washington. *Heritage Research Associates Report* No. 83. Eugene, Oregon.
- 2006 Clay Tobacco Pipes and the Fur Trade of the Pacific Northwest and Northern Plains. *Historic Clay Tobacco Pipe Studies Research Monograph* 1. Phytolith Press, Ponca City, Oklahoma.
- Rapaport, Ben
 1994 Pipes of Our Presidents. *Antiques and Collecting* pp.25-27, 30. November.
- Seeliger, M.
 1993 Pfeifenmacher und Tonpfeifen zwischen Weser und Hartzforland. *Beiträge zur Volkskunde in Niedersachsen* 6.
- Shurke, Peter
 1968 Presidential Campaign Pipes from the Collection of Peter Shurke. *Spinning Wheel* pp. 52-53. November.
- Steen, Carl
 2002 *The MEHRL Project: Archaeological Investigations at the Hollings Marine Laboratory*, Fort Johnson, Charleston, SC
- Stephan, Hans-Georg
 1995 *Grossalmerode, Ein europäisches Zentrum der Herstellung von technischer Keramik Teil 2*. Glas- und Keramikmuseum Grossalmerode, Germany.
- Stilts, John
 2002 Personal Communication with Richard Gartley.
- Sudbury, Byron
 1979 Historic Clay Tobacco Pipemakers in the

- United States of America. The Archaeology of the Clay Tobacco Pipe II. America I. *British Archaeological Reports, International Series* 60:151-341. Oxford, England.
- 2002 "Odds and Ends-Logo." <http://www.claypipes.com/odds.html> (September 4, 2005).
- 2003a Historic Clay Tobacco Pipes in the United States. Power Point Presentation presented at Fort Union National Historic Site, Williston, North Dakota, July 31, 2003. [Copy retained in author's files.]
- 2003b "Historic Clay Tobacco Pipes in the United States." Handout Distributed at the Certification Training Session of the Oklahoma Anthropological Society accompanying the Power Point presentation titled Historic Clay Tobacco Pipes in the United States, Norman, Oklahoma, September 6, 2003. [Copy retained in author's files.]
- Sullivan, Edmund B.
1980 Political Pipes. *Collecting Political Americana*, pp. 152-154.
- Thomas, B.B. (Ted), Jr.
1973 Collecting Presidential Clay Pipes. *The Political Collector* 3(3):3-4. October.
- Waselkov, Gregory A.
2002 *Old Mobile Archaeology*. Center for Archaeology, The University of South Alabama. http://www.southalabama.edu/archaeology/old_mobile/clothing_and_personal_items.htm
- Watkins, Lura Woodside
1968 *Early New England Potters and Their Wares*. pp. 92-93, 134-135, 166-167. Archon Books (Reprint of the 1950 Harvard University Press edition).
- White House
2006 *Presidential Histories Posted on the Official White House History Web Page*, <http://www.whitehouse.gov/history/presidents/>
- Wilson, Rex L.
1971 *Clay Tobacco Pipes From Fort Laramie National Historic Site and Related Locations*. Division of Archaeology and Anthropology, Office of Archaeology and Historic Preservation, National Park Service, U.S. Department of the Interior.
- Michael A. Pfeiffer
Archaeologist
USDA Forest Service
mpfeiffer@fs.fed.us
- Richard T. Gartley
Muskingum Valley Archaeological Survey
mattfoy2000@yahoo.com
- J. Byron Sudbury
Consultant
J. S. Enterprises of Ponca City
jschemistry@hotmail.com

Appendix A⁷
President Pipes and Presidential Candidates

Name	Party	Dates of Office
George Washington	Federalist	1789-1797
John Adams	Federalist	1797-1801
Thomas Jefferson	Democratic Republican	1801-1809
James Madison	Democratic Republican	1809-1817
James Monroe	Democratic Republican	1817-1825
John Quincy Adams	Democratic Republican	1825-1829
Andrew Jackson	Democrat	1829-1837
Martin Van Buren	Democrat	1837-1841
William Henry Harrison	Whig	1841
John Tyler	Whig	1841-1845
James K. Polk	Democrat	1845-1849
Henry Clay		Lost three Presidential elections⁸
Zachary Taylor	Whig	1849-1850
Lewis Cass	Democrat	Lost 1848 election to Taylor
Millard Fillmore	Whig	1850-1853
Franklin Pierce	Democrat	1853-1857
James Buchanan⁹	Democrat	1857-1861
Abraham Lincoln	Republican	1861-1865
Andrew Johnson	Union	1865-1869
Ulysses S. Grant	Republican	1869-1877
Peter Cooper	Ran for President, 1876, Greenback Party. (Painter, 1969:47)	
Rutherford B. Hayes	Republican	1877-1881
James Garfield	Republican	1881
Chester Arthur	Republican	1881-1885
Grover Cleveland	Democrat	1885-1889
Benjamin Harrison¹⁰	Republican	1889-1893
Grover Cleveland	Democrat	1893-1897
William McKinley	Republican	1897-1901
William Jennings Bryan	(Lost to McKinley in 1896 and to Taft in 1908)	
Theodore Roosevelt	Republican	1901-1909
William H. Taft	Republican	1909-1913
Woodrow Wilson	Democrat	1913-1921
Warren G. Harding	Republican	1921-1923
Calvin Coolidge	Republican	1923-1929
Herbert Hoover	Republican	1929-1933
Franklin D. Roosevelt	Democrat	1933-1945
Harry S. Truman	Democrat	1945-1953
Dwight D. Eisenhower	Republican	1953-1961
John F. Kennedy	Democrat	1961-1963
Lyndon B Johnson	Democrat	1963-1969
Richard M. Nixon	Republican	1969-1974
Gerald Ford	Republican	1974-1977
Jimmy Carter	Democrat	1977-1981
Ronald Regan	Republican	1981-1989
George H. W. Bush	Republican	1989-1993
William Clinton	Democrat	1993-2001
George W. Bush	Republican	2001-2009

⁷ Highlighted individuals have pipes illustrated in this article.

⁸ 1824 as Democratic Republican; 1832 as a National Republican; 1844 as a Whig.

⁹ White ball clay stemmed pipe

¹⁰ White ball clay stemmed pipe (a similar pipe was made in the likeness of Grover Cleveland).

LATEX PEELS: A METHOD FOR PRESERVING NATURAL AND CULTURAL STRATIGRAPHY

by

WILLIAM ECKERLE AND JEANNE M. MOE

ABSTRACT

This article describes the methodology and application of latex peel technology for documenting natural and cultural stratigraphy. The techniques discussed are for mounting a cleaned profile surface layer, several millimeters thick, upon a permanent flexible backing. Latex peels are rapid and inexpensive to construct, portable and compact. Their use permanently and accurately documents details of depositional strata, soil horizons, micro-stratigraphy, and fabric of unconsolidated sediments. They are valuable for recording cultural strata including occupation levels, stains, and features for future reference in the laboratory.

INTRODUCTION

Photo documentation and scaled profile drafting are typically used to create a record of archaeological site stratigraphy. Often it is desirable to have a portable physical record of the stratigraphy. This article describes the use and construction of latex peels for the purpose of documenting the stratigraphic relationships of archaeological sites. Latex peels produce a mirror image of stratigraphy preserved as a thin layer of sedimentary grains adhering to a backing and adhesive medium. Descriptions of various technologies used to construct sediment peels have been presented in the literature (Goldberg 1974). Latex peels offer some advantages over other more rigid types of peels.

Techniques for constructing latex peels were first developed by McKee (1966) who used them for studying sand dune stratigraphy. A brief description of this procedure is presented by Klein (1971). This process of

constructing latex peels of profiles was adapted at the Split Rock Ranch site, (48FR1484; Eakin et al. 1997) to provide a permanent record of pit house wall morphology.

Latex peels are easily constructed on profiles exposed during the excavation process. In most circumstances the profile itself remains undamaged while taking the peel. Because the cloth and latex backing of the peel is flexible, the finished peels may be either attached to rigid backing for temporary viewing or rolled up and boxed for permanent storage. Peels constructed at the Split Rock Ranch site were rolled for transport and storage and were subsequently unrolled several times for the analysis and educational purposes. In the 21 years since their construction the peels remain durable and pliable. Although individual grains have fallen off none of the peels sustained any major damage or attrition. Because the peel removes a layer of sediment, the soil colors of sedimentary and cultural strata are well preserved and in some cases soil structure, e.g., massive, blocky, columnar, may also be preserved. When completed, latex peels provide permanent documentation of unconsolidated sediments. They provide an accurate record of macro and micro-stratigraphy and soil horizonation, as well as the spatial relationships of observable cultural strata.

PROCEDURES

The surface to be peeled must be relatively smooth (Klein 1971:229) without protrusions, e.g. rocks or clods. Waves or undulations in the surface do not cause any major difficulties because the latex and cheesecloth backing is flexible and will follow the surface contours. Adequate preparation of the surface can be accomplished in a few minutes to an hour depending on the amount of irregularities present.

Through a process of trial and error it was found that the profile must be completely dry before a sealer (Krylon®) is applied. Profiles that were prepared by

NOTE: Trade names used in this publication do not necessarily imply endorsement of any specific product by the author, the Wyoming Archaeological Society or any of its members.

using water to soften the sediments were allowed to dry over night in the open air. If rain or heavy dew occurred during the night, additional drying time was allowed the following morning.

Several coats of Krylon® were sprayed on the surface and five minutes of drying time was allowed between each coat (Figure 1). This sealer coat prevents weakly coherent sediment from being dislodged by the brush as the first coat of latex is applied. On this project, Krylon® No. 1306 Workable Fixative spray coating was used. It is made by Borden, Inc., Dept. CP., Columbus, Ohio 43215. Klein (1971:Table 6) suggests the use of Krylon Crystal Clear Spray #1303 made by the Krylon Corp., Norristown, Pennsylvania. After application of the last coat, approximately 30 minutes of drying time was allowed. Between four and six coats of Krylon were found to be sufficient.

Latex cement was then applied directly from the container using a soft paint brush. The cement used was Weldwood Latex Cement (DAP, Inc., Baltimore, MD)

which is stocked by many general building supply outlets. Klein (1971:Table 6) suggests the use of Cementex #600 latex cement made by the Cementex Co., New York. Artist's latex gesso has also been used for this application (Kornfeld: personal communication. Many latex cements would probably perform satisfactorily. In any case, there should be little or no acrylic in the cement or the Krylon coating will be melted on contact.

Coverage of the profile should be as even as possible. Locations where the cement is applied too thin may not adhere well to the Krylon whereas thicker coatings will not dry well. One coat of latex cement is sufficient before application of a cheesecloth backing. The cheesecloth provides a structural backing that adds strength to the peel (Figure 2). The cheesecloth should be applied by brushing it into the wet latex. If the cheesecloth needs spliced at least a 10 cm overlap is required. Latex will dry quickly on a very warm day. A second coat of latex is applied over the top of the cheesecloth after the first coat is dry. Klein (1971:230) suggests waiting a half hour. At

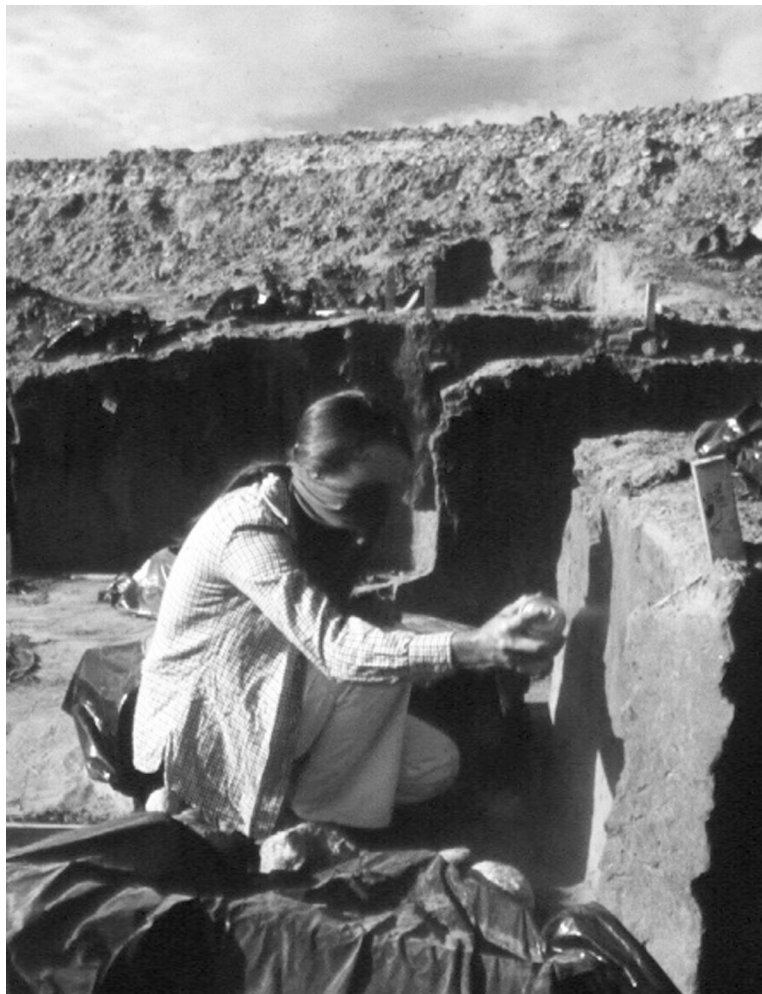

Figure 1: “Krylon®” sealer being sprayed on profile at the Split Rock Ranch site.



Figure 2: Profile wall with cheese cloth applied to latex.

the Split Rock Ranch Site, it was found that 3-4 hours were required for the first coat to dry. The second coat was allowed to dry overnight. Different latex products will require individualized drying times. The peels were covered with plastic if overnight precipitation seemed imminent and the next morning the cover was removed and the peel allowed to dry. Drying is dependent on moisture and temperature conditions. Thus success is more difficult in cool and damp weather.

The peels were removed starting at the top of the profile and working downward. Large chunks or soil clods had to occasionally be broken away from the backing as peeling progressed. Occasionally very large clods would adhere to the backing. These were broken up by gently using a trowel, still leaving a layer of sediment adhering to the backing. After removal from the profile wall, the peels were laid flat, matrix side up, and allowed to air dry for 2-3 hours (Figure 3). Several coats of Krylon were then applied to the exposed surface allowing five minutes drying time between coats.

As was mentioned above the peels may be rolled for transport and storage. Although this does cause some rubbing and loss of grains, the damage is not appreciable especially if the roll is supported with a map or carpet tube. The finished peels may be attached to plywood backing for permanent laboratory display. The peels are relatively inexpensive to construct. It is estimated that each 1 sq. meter peel cost approximately \$10.00 for materials and consumed a maximum of 2-3 person hours to construct.

CONCLUSIONS

Latex peels are relatively easily and inexpensively constructed. They provide a permanent record of site stratigraphy that is usable for later laboratory analysis or educational purposes. Materials used in their construction are relatively inexpensive and available. The techniques described are easily executed although care should be taken that the profile is dry when starting the procedure. Finally, latex peels are easily stored when rolled.



Figure 3: Peel after removal being cleaned and inspected.

REFERENCES CITED

Eakin, Daniel H., Mary Lou Larson, and Julie Francis
1997 The Split Rock Ranch Site: Early Plains Archaic Adaptation in Central Wyoming. In *Changing Perspectives of the Archaic on the Northwestern Plains and Rocky Mountains*, edited by Mary Lou Larson and Julie Francis. pp. 394-449. University of South Dakota Press, Vermillion.

Goldberg, Paul S.
1974 Sediment Peels from Prehistoric Sites. *Journal of Field Archaeology* 1:323-328.

Klein, G. deV,
1971 A Sedimentary Model for Determining Paleotidal Range. *Geological Society of America, Bulletin* 82:2,585-2,592.

McKee, E.D.
1966 Structures of Dunes at White Sands Na-

tional Monument, New Mexico (And a Comparison with Structures of Dunes from Other Selected Areas). *Sedimentology* 7(1):1-69.

William Eckerle
Western GeoArch Research
P.O. Box 521124
Salt Lake City, UT 84152

Jeanne M. Moe
Project Archaeology
2-128 Wilson Hall
Montana State University
Bozeman, MT 59717

HAFTED STONE TOOLS: A LOOK AT HUNTER-GATHERER EXAMPLES FROM THE CENTRAL AND NORTHWESTERN PLAINS

BY
CODY NEWTON

ABSTRACT

Chipped stone is a ubiquitous part of the prehistoric hunter-gatherer archaeological record in the Great Plains and Rocky Mountains. It has long been recognized many chipped stone tools represent one element of a composite tool system which includes other perishable materials, such as wood and animal products. Because these latter materials rarely preserve, understanding the role of stone tools in prehistoric contexts is difficult. Although rare, some complete examples of these composite tools do exist. In this paper, published intact composite tools from hunter-gatherer sites in Montana, Wyoming, Colorado, and Nebraska are summarized. The goal of this study is to decipher the technological organization of hafted stone tools in order to better the technological role of stone tools, which are a large part of the hunter-gatherer archaeological record.

INTRODUCTION

Lithic artifacts are the most recognized and studied aspect of prehistoric material culture in the Great Plains and Rocky Mountain region. Lithic materials represent the most durable form of artifact and are often the only artifacts to withstand the destruction caused by human and environmental processes (Andrefsky 2005:1). The study of chipped stone has been an essential tool in the archaeological reconstruction of prehistoric hunter-gatherer lifeways.

Chipped stone assemblages from archaeological sites often contain formal stone tools. These tools are an important component of not only lithic analysis but overall site analysis as well. Projectile points, in particular, are often used to distinguish between different prehistoric groups and establish chronology (e.g., Frison 1991; Mulloy 1958). Beyond site assemblage analysis, archaeologists use replication and experimental studies to estimate the prehistoric use and effectiveness of projectile points (e.g., Frison 1991; Frison 2004; Hunzicker 2005).

Experimental approaches allow archaeologists to better understand the effectiveness of prehistoric technology. Studies such as those by Browne (1938, 1940) demonstrated the potential capability of the bow and arrow system. Other experiments, such as those by Frison (1989), showed these systems were capable of at least fatally wounding prey animals. There are also data available through ethnohistoric accounts giving insight into how prehistoric groups may have used their weaponry (e.g., Swanton 1938). These accounts have given archaeologists information on how the more perishable and underrepresented parts of a prehistoric weapons system could have been organized.

Stone tools used in butchering and food processing have not received the same amount of analytical attention as projectile points. Along with prehistoric weaponry systems, certain butchery and food processing tools were part of composite systems. Ethnohistoric assemblages provide examples of these types of complete tools (Fowler and Matley 1979; Nordenskiöld 1979). Overall, however, study of prehistoric composite tools is hampered by the lack of complete specimens from the archaeological record.

The manufacture and maintenance of composite tools is an acknowledged aspect of prehistoric hunter-gatherer technology throughout antiquity. Keeley (1982:798) states:

Stone implements have been hafted certainly since the Upper Paleolithic and quite probably since the Middle Paleolithic. The idea that many of the lithic artifacts recovered from sites were originally hafted is so obvious that lengthy consideration of its significance seems pedantic and superfluous.

The fact hafting elements are acknowledged, yet largely underrepresented in the archaeological record, is problematic. It limits our understanding of prehistoric tools; despite acknowledgment of hafting, the recovered

lithic element generally recovered is often treated as a complete, independent tool. The labeling of chipped stone elements as “tools” is a misnomer because this implies they are complete and usable.

This treatment of chipped stone tools as independent tools is inappropriate, especially because there are complete hafted tools recovered from prehistoric contexts that do retain all of their elements, both perishable and non-perishable. The study of these artifacts can give insight into the technological organization of the prehistoric hunter-gatherer groups that manufactured and used them.

PURPOSE

Hunter-gatherer archaeology depends almost solely on the material culture left behind by prehistoric people. Certain parts of this material culture decay more quickly than others and consequently these aspects are less understood. The perishable nature of hafted tool elements often precludes these artifacts from preserving in the archaeological record. Consideration of the effects hafting could have on our interpretations of the archaeological record is often neglected despite its significance (Keeley 1982:798-799). There are examples from the archaeological record, however, that retain these perishable parts and can be studied. Through the investigation of these examples, it may be possible to infer behaviors and technology to other artifact assemblages less complete.

The study of complete hafted specimens permits us to estimate what is missing from assemblages retaining only part of a composite whole, which is in most cases the lithic component. Published complete hafted examples from prehistoric hunter-gatherer sites in the Central and Northwestern Plains has been compiled and this sample is analyzed to increase the knowledge base concerning hafted tool typology and technological organization. Though this study is not comprehensive (e.g., the gray literature was omitted), the information presented provides a baseline for future studies

DATA COLLECTION

Complete examples of hafted stone tools have been recovered from archaeological sites throughout the western United States. The work of early archaeologists in the arid regions of the west and southwest provided the majority of the known specimens. Sites such as Lovelock Cave (Loud and Harrington 1929) and Gypsum Cave (Harrington 1933) in Nevada and sites in the Great Salt Lake region excavated by Steward (1937) and others (see Aikens 1970; Cosgrove 1947; Gunnerson 1969; Jennings 1957; Jennings 1978; Wheeler 1973) have yielded complete hafted specimens. Complete hafted stone tools from north and east of the Great Basin and Utah are less common. As mentioned above, the Central

and Northwestern Plains define the research area. This area was dictated by logistical considerations, but most importantly, was selected because any previous study of this sort in the region is lacking.

The data gathering process began with searching the regional anthropological journals, along with more widely diverse journals, such as *American Antiquity*. From here, a bibliography was started and potential references were examined to determine if each site contained examples suitable for the study. Specimens were included in the sample if the chipped stone element was still contained in the hafting element so there was no ambiguity about the manner of hafting or materials used. Also, specimens were considered complete for the purposes of this study even if the hafting element was incomplete (e.g., a hafted projectile point on a broken shaft) because these tools still had all elements of the hafting present. The final sample includes 26 complete examples from 15 sites or locales from Montana, Wyoming, Colorado and Nebraska (Figure 1).

DATABASE

Table 1 provides general information on the sites where the hafted tools used in this sample were recovered derived from published reports. As shown, there are some basic similarities and constraints exhibited by the sites permitting the recovery of complete hafted examples. All sites are rock shelters, excluding Hagen, which is an open campsite, and possibly 25FR22. The dry depositional context of rockshelters favors the preservation of perishable hafting elements. These specimens derive from contexts dating to the Late Archaic or more recent periods. The sites with associated radiocarbon dates are Late Archaic to Late Prehistoric in age. Those lacking radiometric dates, can, for the most part, be placed into the same age bracket by relative dating.

Table 2 is a summation of the individual specimens from the published literature. Note the column denoting the number of individual elements composing each specimen. An individual element is roughly analogous to a technounit as employed by Oswalt (1976:38). Oswalt uses the number of technounits as means to gauge the complexity of subsistence technology. The basic unit concept is used in this study, as well, but unlike Oswalt, it is used only to measure the basic complexity of tools rather than subsistence technology. In all cases, the number of elements composing a specimen is three or greater and this indicates the primary elements comprising these tools. The three elements are the (1) chipped stone inserted into a (2) handle and stabilized with some sort of (3) binding agent.

The sample can be divided the specimens into two basic groupings: propelled tools and non-propelled

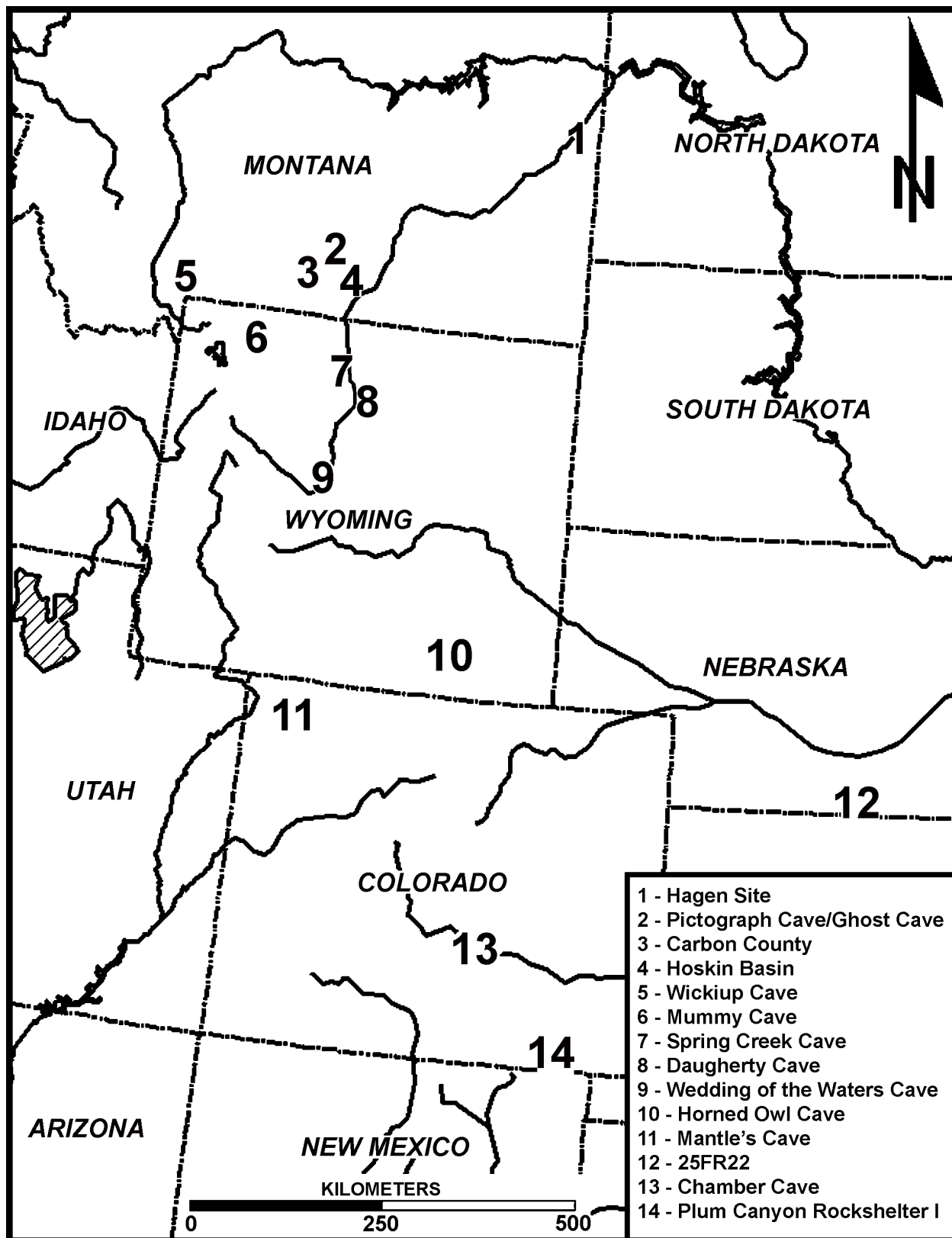

Figure 1: Map of sites or localities where hafted stone tools from sample were recovered.

Table 1: Hafted stone tool sample site information.

SITE	STATE	COUNTY	SITE #	AGE	DESCRIPTION	# HAFTED	REFERENCE
Daughtery Cave	WY	Washakie	48WA302	Late Archaic or Late Prehistoric	small blade in shaft;	2	Frison 1968
Horned Owl Cave	WY	Albany	48AB305	Late Archaic or Late Prehistoric	knife w/partial wood	1	Gebhard et al. 1964
Mummy Cave	WY	Park	48PA201	Late Prehistoric	compound arrow shaft w/ point; miniature hafted point	2	Husted and Edgar 2001
Spring Creek Cave	WY	Washakie	48WA1	1230 +/- 110 B.P. Late Prehistoric	two hafted dart pints in Foreshaft	2	Frison 1965
Wedding of the Waters Cave	WY	Hot Springs	48HO301	A.D. 225 +/- 200 Late Archaic	dart point in foreshaft	1	Frison 1962
Carbon County	MT	Carbon	-----	1620 +/- 165 B.P. Late Prehistoric or Protohistoric	compound arrow w/hafted foreshaft and nockshaft	1	Cramer 1978
Ghost Cave	MT	Yellowstone	24YL2	Late Prehistoric	3 points w/partial shafts; 3 knives (2 wood/1 bone)	6	Mulloy 1958
Hoskin Basin	MT	Yellowstone	-----	A.D. 500 Late Prehistoric or Protohistoric	knife in wooden handle	1	Cramer 2001
Pictograph Cave	MT	Yellowstone	24YL1	Late Prehistoric	two points w/partial shafts; one is possible knife	2	Mulloy 1958
Hagen	MT	Dawson	24DW2	A.D. 500 Late Prehistoric or Protohistoric	knife w/bone handle	1	Mulloy 1942
Wickiup Cave	MT	Beaverhead	24BE601	possibly Protohistoric	arrow point attached to partial shaft	1	Davis 1975
25FR22	NE	Franklin	25FR22	Late Precontact A.D. 1000-1400	knife w/bone handle	1	Bozell 1994
Chamber Cave	CO	Pueblo	5PE1767	Late Prehistoric	hafted point in foreshaft; knife w/wood handle	2	Nelson 1970
Mantle's Cave	CO	Moffat	5MF1	Panhandle Aspect Late Prehistoric	knife w/wood handle;	2	Burgh and Scoggin 1948
Plum Canyon Rockshelter I	CO	Las Animas	5LA2158	Late Prehistoric A.D. 900-1250	knife w/bone handle	1	Butler 1985

Table 2: Hafted stone tool information.

SITE	SPECIMEN	NUMBER OF ELEMENTS	HANDLE OR SHAFT	MATERIAL TYPE	MATERIAL TYPE	KNIFE OR POINT	MATERIAL TYPE	BINDING ELEMENT	BINDING METHOD	COMPLETE EXAMPLE
Daugherty Cave	1	3	handle	skunkbrush	obsidian	knife	obsidian	sinew		yes
Daugherty Cave	2	3	handle	cottonwood	unspecified	knife	unspecified	missing		yes
Horned Owl Cave	3	3	handle	pine	quartzite	knife	quartzite	mastic		no
Mummy Cave	4	3	foreshaft	willow	unspecified	arrow	unspecified	sinew	B	yes
Mummy Cave	5	3	shaft	unspecified wood	unspecified	arrow	unspecified	sinew	B	no
Spring Creek Cave	6	3	foreshaft	unspecified wood	unspecified	dart	unspecified	sinew	A	yes
Spring Creek Cave	7	3	foreshaft	unspecified wood	unspecified	dart	unspecified	sinew	A	no
Wedding of the Waters Cave	8	3	foreshaft	willow or chokecherry	unspecified	dart	unspecified	sinew	A	yes
Carbon County, MT	9	4	foreshaft	unspecified wood	chalcedony	arrow	chalcedony	sinew/mastic	A	yes
Ghost Cave	10	4	shaft	unspecified wood	unspecified	arrow	unspecified	sinew/pitch	A	no
Ghost Cave	11	3	shaft	unspecified wood	unspecified	arrow	unspecified	sinew	unknown	no
Ghost Cave	12	3	shaft	unspecified wood	unspecified	arrow	unspecified	sinew	unknown	no
Ghost Cave	13	3	handle	unspecified wood	unspecified	knife	unspecified	sinew		yes
Ghost Cave	14	4	handle	unspecified wood	unspecified	knife	unspecified	sinew/mastic		yes
Ghost Cave	15	3	handle	unspecified bone	unspecified	knife	unspecified	missing		yes
Hoskin Basin	16	4	handle	unspecified wood	chert	knife	chert	sinew/mastic		yes
Pictograph Cave	17	4	both	unspecified wood	chert	both	chert	sinew/mastic	A	yes
Pictograph Cave	18	5	shaft	unspecified wood	chert	arrow	chert	sinew/mastic, gilsonite	unknown	no
Hagen	26	3	handle	bison vertebra	unspecified	knife	unspecified	pitch		yes
Wickiup Cave	19	3	shaft	elm or cottonwood	chert	arrow	chert	sinew	A	no
25FR22	20	3	handle	bison rib	unspecified mastic	knife	unspecified	mastic		yes
Chamber Cave	21	3	foreshaft	unspecified wood	unspecified	arrow	unspecified	sinew	A	no
Chamber Cave	22	3	handle	unspecified wood	unspecified	knife	unspecified	rawhide		yes
Mantle's Cave	23	4	handle	cottonwood	unspecified	knife	unspecified	willow splints, pine gum		yes
Mantle's Cave	24	3	handle	unspecified wood	unspecified	drill	unspecified	rawhide		yes
Plum Canyon Rockshelter I	25	3	handle	bison scapula	quartzite	knife	quartzite	mastic		yes

tools. In this sample, propelled tools include arrows or darts and non-propelled tools include knives and a possible drill. Prehistoric people likely used hafted arrows and darts for cutting and knives may have been thrown, but this dichotomy is useful because this analysis is concerned with *intended* tool use rather than incidental tool use.

The material types used were wood or bone for the handle or shaft and stone for the blade or point. In the cases where the handle or shaft material was specified, the wood or bone used was of a locally available species. The derivation of the lithics is harder to discern without specific sourcing of the material. The obsidian used for the blade in Specimen #1 is the only case in which the material is definitely unavailable in the immediate site area. The binding elements used on the examples are mainly sinew, mastic, or both, with the exception of willow splints and pine gum used in Specimen #23. The bone handled knives show at most only one binding element whereas the wooden handled knives are more varied and exhibit multiple binding elements in some cases. When possible (n=10) the wrapping method used on the arrow and dart specimens was recorded according to Figure 2. A Chi-Square test indicates there is a significant relationship between wrapping method A and the presence of notches ($\chi^2=5.833, df=1, p=0.016$). This probably indicates notching facilitated the cross wrapping method and was a more secure method of hafting.

Using the scaled figures provided in the publications, measurements were taken on each specimen (Table 3). Figures 3, 4, and 5 describe the measurements taken for arrows/darts, side-hafted knives and end-hafted knives respectively. Total length (TL) and handle length (HL) were only included in the table for specimens with intact handles or shafts. Specimen #20 is not included because the published figure did not include a scale.

ANALYSIS

The hafted stone tools from the sample can be grouped based on morphological characteristics probably reflecting different prehistoric uses and technological considerations. The hafted points in the sample are categorized for use in either a bow and arrow or atlatl and dart system. There has been much debate over how to distinguish between the projectile points used as darts and those used as arrowheads (Bettinger and Eerkens 1999; Nassaney and Pyle 1999). Thomas (1978) presented a quantitative analysis of hafted projectile points from museum collections to develop classification equations that could be used to differentiate arrowheads from dart points in non-hafted specimens. Shott (1997) extended Thomas’s approach and increased the hafted dart sample with more museum

specimens. This sample of hafted arrows and darts contains specimens from predominately west of the Rocky Mountains and the desert Southwest. Although the Thomas and Shott samples contain no specimens from the Central and Northwestern Plains, because identical measurements were used, specimens from this study could be compared to see if the samples are statistically similar.

The Thomas sample of hafted arrows (n=132) was compared against the sample (n=7) from this study. T-tests indicate the two samples are not significantly different at the $\alpha=0.05$ based on the variables of shoulder width ($t=-0.449, df=137, p=0.654$), neck width ($t=-0.752, df=138, p=0.453$), total point length ($t=-1.451, df=134, p=0.149$) and shaft width ($t=-0.502, df=138, p=0.616$). An analysis of variance (ANOVA) between the darts from Thomas (n=10), Shott (n=30) and this sample (n=2) indicate they are not statistically different based on the mutual variables of shoulder width ($F_{(2,39)}=0.062, p=0.940$), neck width ($F_{(2,40)}=1.523, p=0.230$) and total point length ($F_{(2,39)}=2.508, p=0.095$). The similarities between the samples indicate a consistency in the manufacture of these hafted projectiles through space

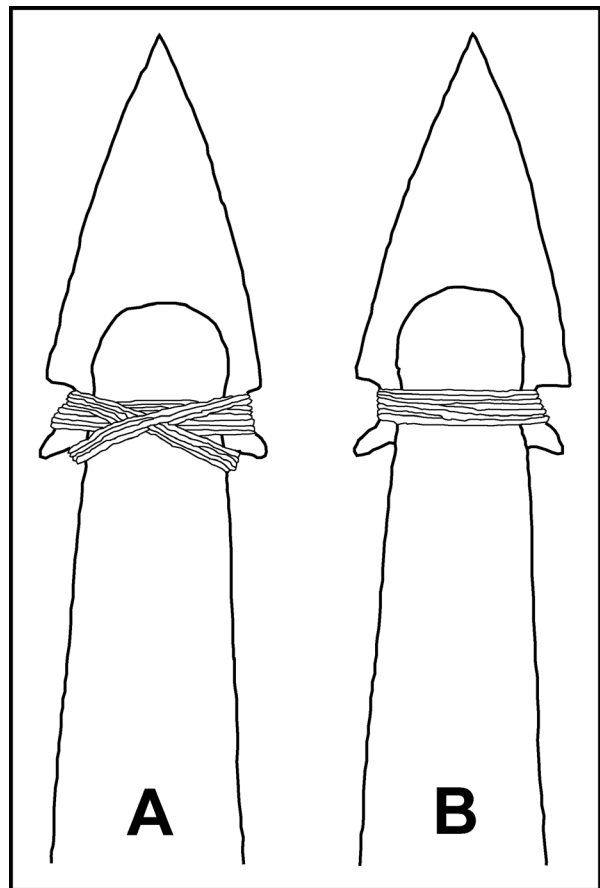

Figure 2: Recorded binding methods used on hafted projectile points.

Table 3: Measurements (mm) from hafted stone tool sample.

SPECIMEN	SHOULDER WIDTH	NECK WIDTH	SHAFT WIDTH	HAFTING DEPTH	BLADE LENGTH	BLADE WIDTH	HANDLE WIDTH	HANDLE LENGTH	STONE LENGTH	TOTAL LENGTH	TYPE
1				10.0	24.6	12.6	5.6	142.1	36.3	166.7	End haft
2.					53.5	33.7	20.4	101.5	62.5		Side haft
3					66.5	28.9	16.1		93.6	102.4	End haft
4	13.9	6.1	7.0							225.0	Arrow
5	10.8	5.1	3.0							19.3	Arrow
6	21.9	12.9	9.7							170.3	Dart
7		16.4	12.1						32.5	78.5	Dart
8	26.3	14.4	11.5	19.1					36.7	208.1	Dart
9	12.0	7.6	6.5	9.3					25.0	146.0	Arrow
10	16.8	12.1	8.5	6.8					22.8	83.8	Arrow
11		12.7	6.9	4.9						56.3	Arrow
12	13.4	10.3	7.1	4.4					18.8	71.2	Arrow
13					28.4	13.8	16.2	63.9	37.8		Side haft
14					53.9	24.6	18.7	176.2	62.4		Side haft
15					74.8		22.1	102.2			Side haft
16					71.7	38.0	25.0	136.0	90.0	207.7	End haft
17						15.2	10.2		26.7	74.5	End haft
18	17.8		9.4						30.5	173.9	Arrow
19		10.5	7.8	9.4						66.0	Arrow
21	13.4	9.1			38.8	22.3	24.9	85.9		124.7	Arrow
22					99.5	43.1	41.2	111.3		210.8	End haft
23					8.0		6.4	635.0		643.0	End haft
24					41.0	25.0	21.0	114.0	46.0		End haft
25			20.0		89.5	35.6	18.6	170.2	97.5		Side haft
26											Side haft

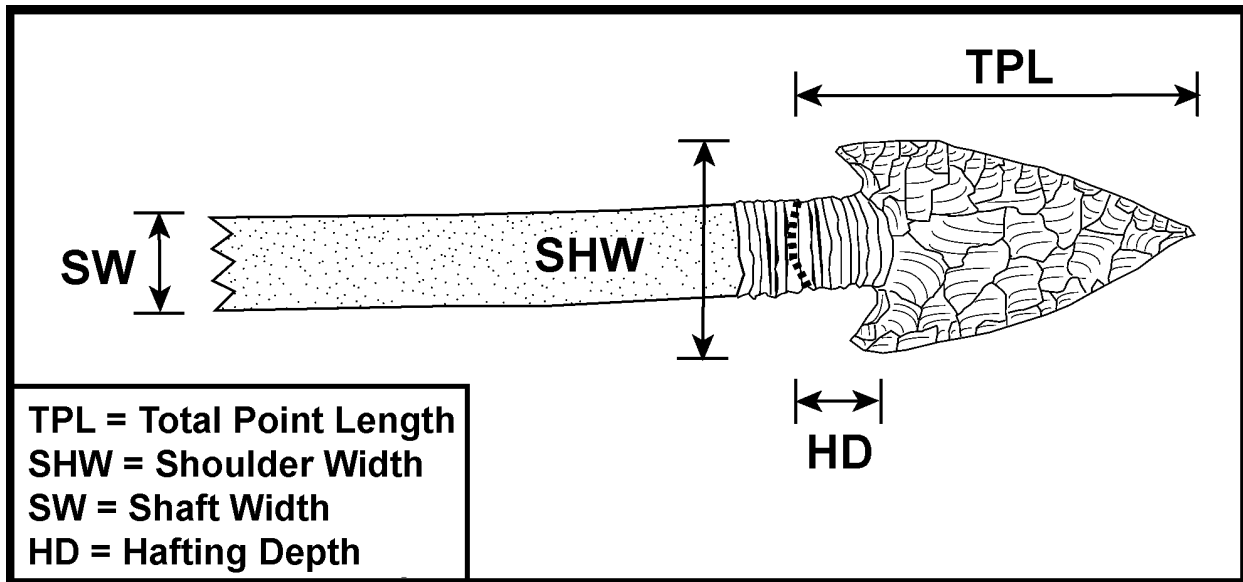

Figure 3: Measurements taken on arrows or darts in sample.

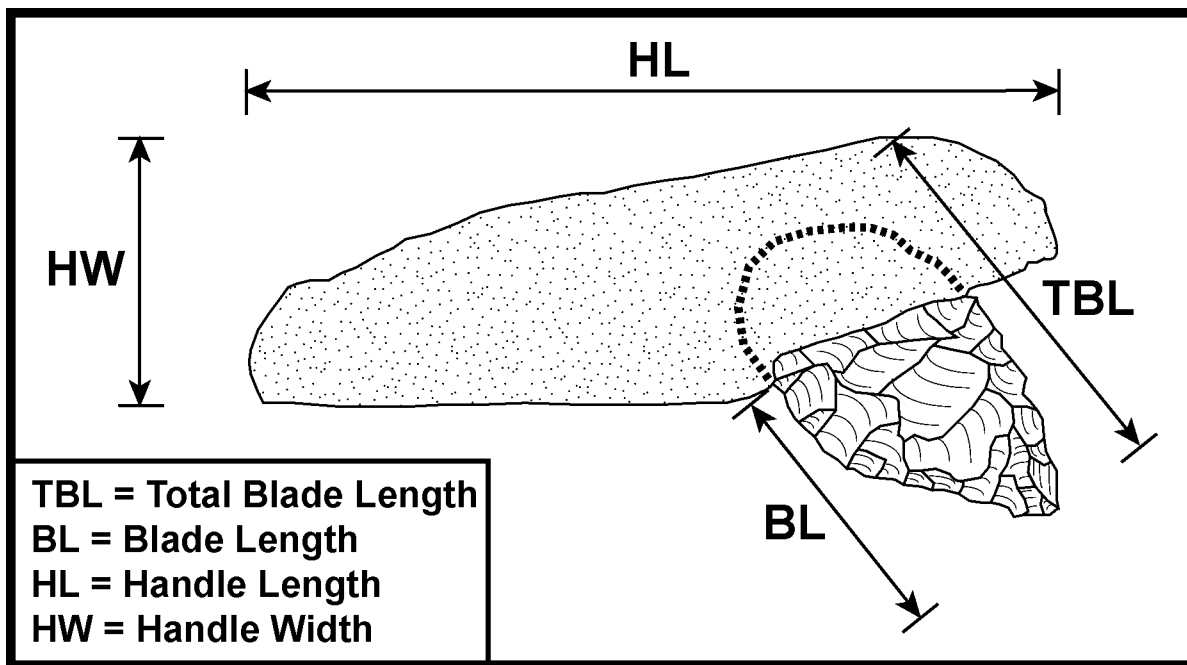

Figure 4: Measurements taken on side-hafted knives in sample.

and perhaps time.

The knives (n=13) in the sample exhibit some basic design differences. As indicated by Stiger (2001:245), hafted stone knives fall into at least three categories: first, those with the blade hafted onto the end of a handle that is as wide or wider than the blade; second, those hafted on the end of a handle that is narrower than the blade; and third, those with the blade hafted onto the side of the handle. This sample contains examples of hafted stone knives falling into each of these categories.

There are four knives (Specimen #'s 16, 22, 23 and 24) with an end-hafted blade equal to or narrower in width than the handle. The four knives of this type all have wooden handles and at least one type of binding element. The shape of this type of knife is very similar to a modern knife with a dagger blade. Specimen #24 is considered to be a drill rather than a knife (Burgh and Scoggin 1948:50) but still meets the criteria of this category. Blade material type was only specified for Specimen #16, which is chert.

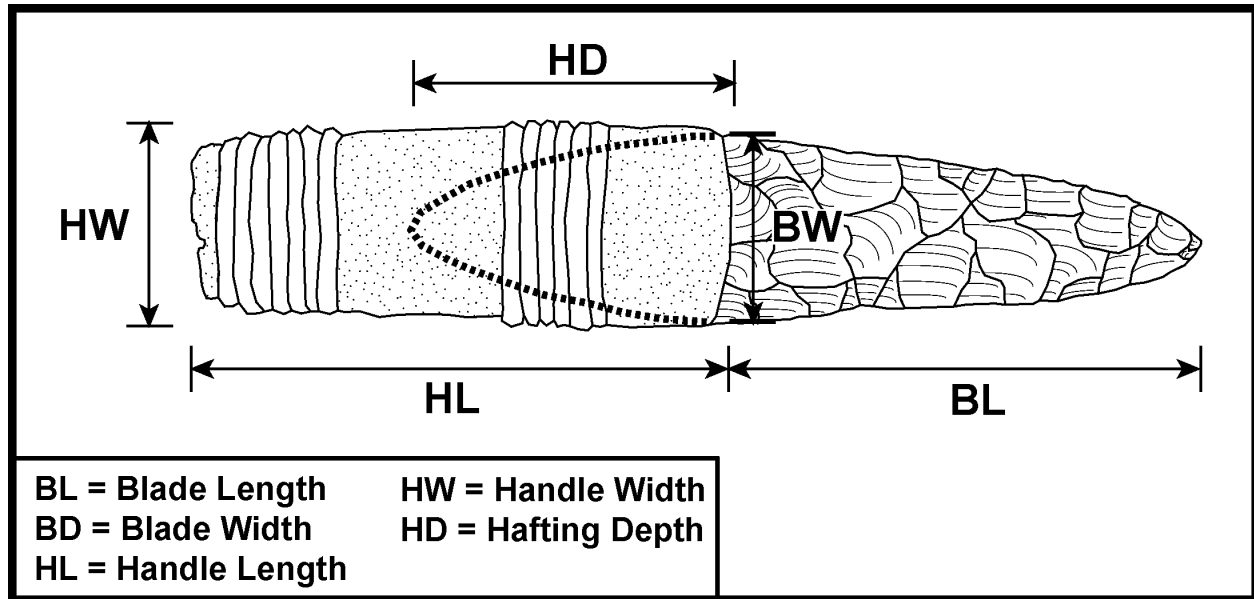

Figure 5: Measurements taken on end-hafted knives in sample.

There are three artifacts (Specimen #'s 1, 3 and 17) where the stone blade is wider than the handle to which it is hafted. Stiger (2001:245) suggests this type might represent a hafted knife which could also be used as part of a projectile point system. This seems to be the case for Specimen #17, which Mulloy (1958:64-65) indicates was possibly a hafted arrow point in which the shaft was cut to make it into a small knife. Specimen #1 is an extremely small blade mounted on an even smaller shaft. This size of this knife is intriguing and could indicate a very specialized purpose.

The majority of the knives in the sample ($n=7$) have the blade hafted into the side of the handle. Four of these specimens have handles manufactured out of bone. Three of the handles are specified as bison bone. The different skeletal elements used to make the handles were a rib, the spinous process of a cervical vertebra and a scapula. The size and shape of these skeletal elements made them suitable as handle with little need for modification. The material used for the blades is only indicated in the case of Specimen #25 which is made of quartzite.

Looking at the variables separately by element (Figure 6) indicates the length and width of the blades are significantly correlated at the $\alpha=0.01$ level. This is not surprising given the limitations of manufacturing items from chipped stone. Also, it is expected the specific intended function of a knife blade would dictate a certain template. The lack of significant correlation between handle length and width could reflect differing material characteristics or morphological considerations based on grasping and leverage. The relationship between handle width and blade width is significantly correlated at the

$\alpha=0.05$ level (Figure 7). The high correlation between the width dimensions of these elements probably reflects need for the handle and blade to fit together for hafting, especially end-hafted knives. Handle length and blade length are not significantly correlated; even in the side-hafted sample, where the length correlation might be more important in hafting, there is no significant relationship ($N=6$, $r=0.600$, $p=0.208$).

Manner of hafting and materials in the knife sample demonstrate patterning. The friction and mastic binding used in the side-hafted knives differed somewhat from the sinew used in the end-hafted examples. The mastic and friction binding method seem to make the act of hafting a more simple and straightforward process than sinew binding. This could have been important if these knives were used for a type of processing that caused short use-life of blades. Mastic could simply be heated to a more viscous state in order to replace the blade.

The wooden material used in hafting was not frequently identified in the literature but some specimens were typed. These specimens contained a wood species available locally in the site area. Most likely these species would have been available at the time of knife manufacture.

CONCLUSIONS AND SPECULATIONS

It is generally accepted the handle or shaft elements of a hafted tool take much longer to manufacture than the lithic elements (Keeley 1982:800). Therefore, it can be argued the haft elements of tools play a significant role in the technological organization of prehistoric populations (Oswalt 1976). The paucity of prehistoric hunter-gatherer examples of hafted stone tools is problematic when trying

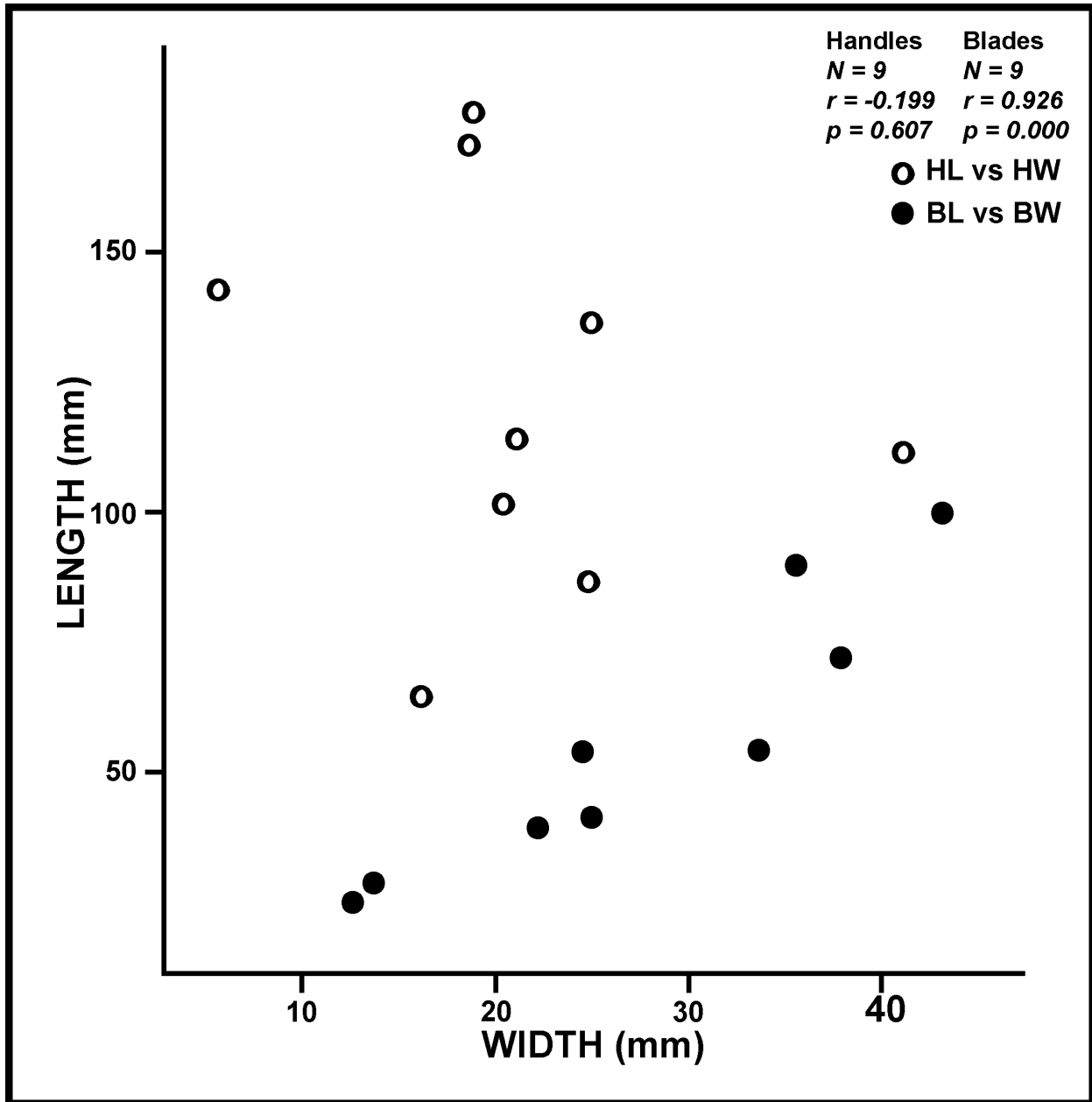

Figure 6: Overlay scatterplot of blade and handle measurements by element.

to discern this component of past culture.

There are definite morphological characteristics crosscutting spatial and temporal scales. In a very basic form the breakdown of the different types can be shown as follows (Figure 8). The focus of this study was the bifacially flaked group (no examples from the other categories were documented for this study). There are some interesting questions raised by the lack of unifacially flaked and grooved examples from all known complete hafted tools. In the region of the study, it is especially interesting that certain tools, such as end scrapers which occur frequently in prehistoric sites, are rarely found

with the hafting element. The literature search for this paper discovered only one hafted specimen from Cave I at Promontory Point in Utah (Steward 1937:70-72). The lack of hafted examples could be due to the specialized nature of these tools (e.g., end scrapers used in hide processing) dictating use at only certain times of the year and differing curation strategies. The materials used to make all hafted tools would have probably been the same, so preservation would not be biased against any one particular tool type.

The selection of raw materials used in the manufacture of hafting elements could have potentially been a strategic

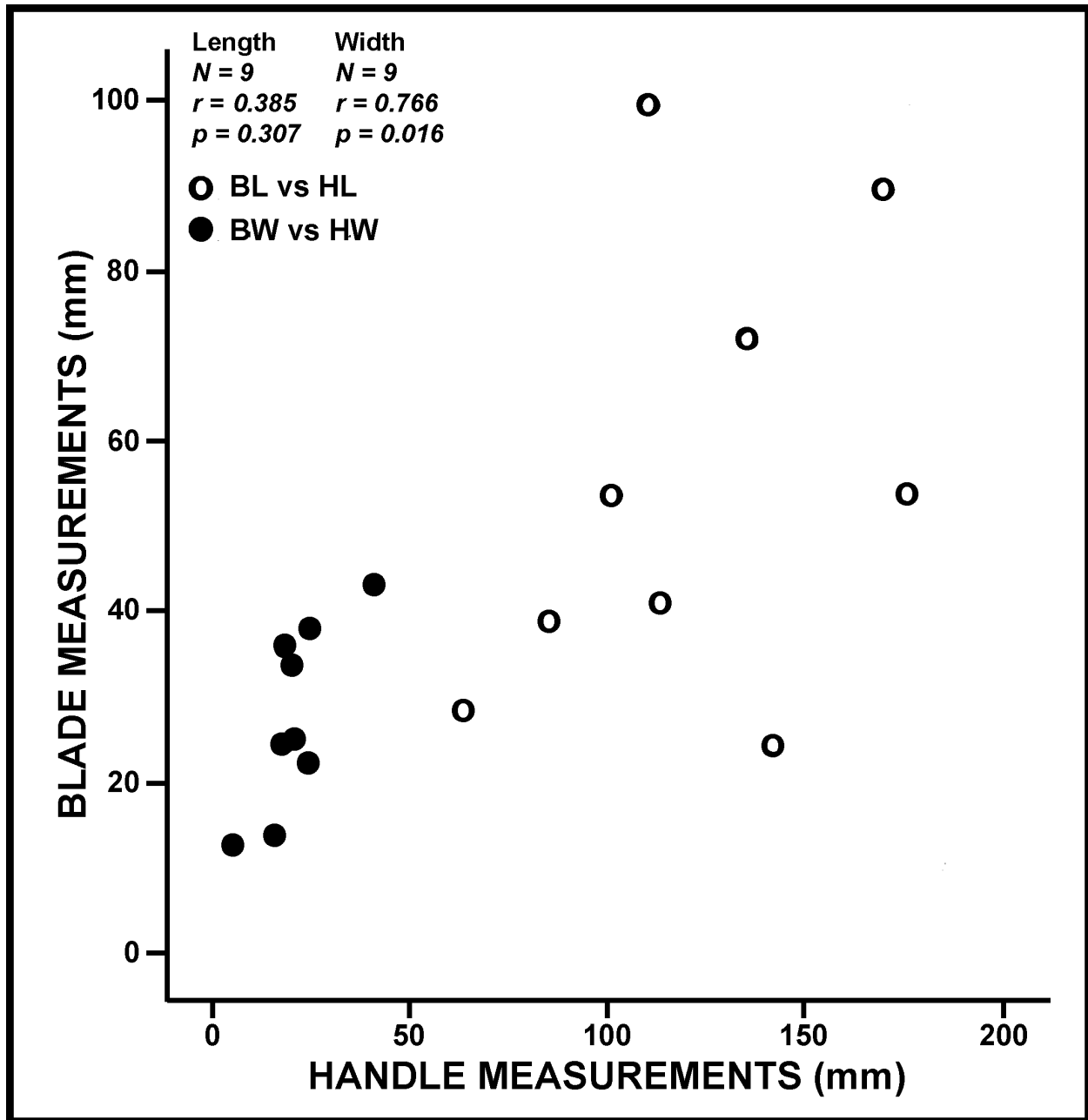

Figure 7: Overlay scatterplot of blade and handle measurements by dimension.

process in much the same way as lithic procurement. At Crystal Cave in South Dakota, recovered hafting elements indicate different types of wood were being used for different parts in the manufacture of compound dart systems (Weathermon 2005). The composite characteristics and morphology of the knives in the sample indicate each type would have performed specialized tasks more efficiently than the other. It is apparent side-hafted knives were designed for cutting in a drawing motion and end hafted knives could be used for a greater variety of cutting strokes.

Understanding the manufacture and use of hafted tools can lead to a more complete knowledge of the ways in which prehistoric people responded to subsistence needs. Local conditions and adaptive choices probably dictated the raw materials used, the manufacture time spent, the shape of each individual element, and finally, how each element was combined to create a composite tool. Complete hafted stone tools were the end result and they provide insight into the entire process. It is through the study of existing hafted artifacts coupled with further replication, experimentation and use-wear analysis that

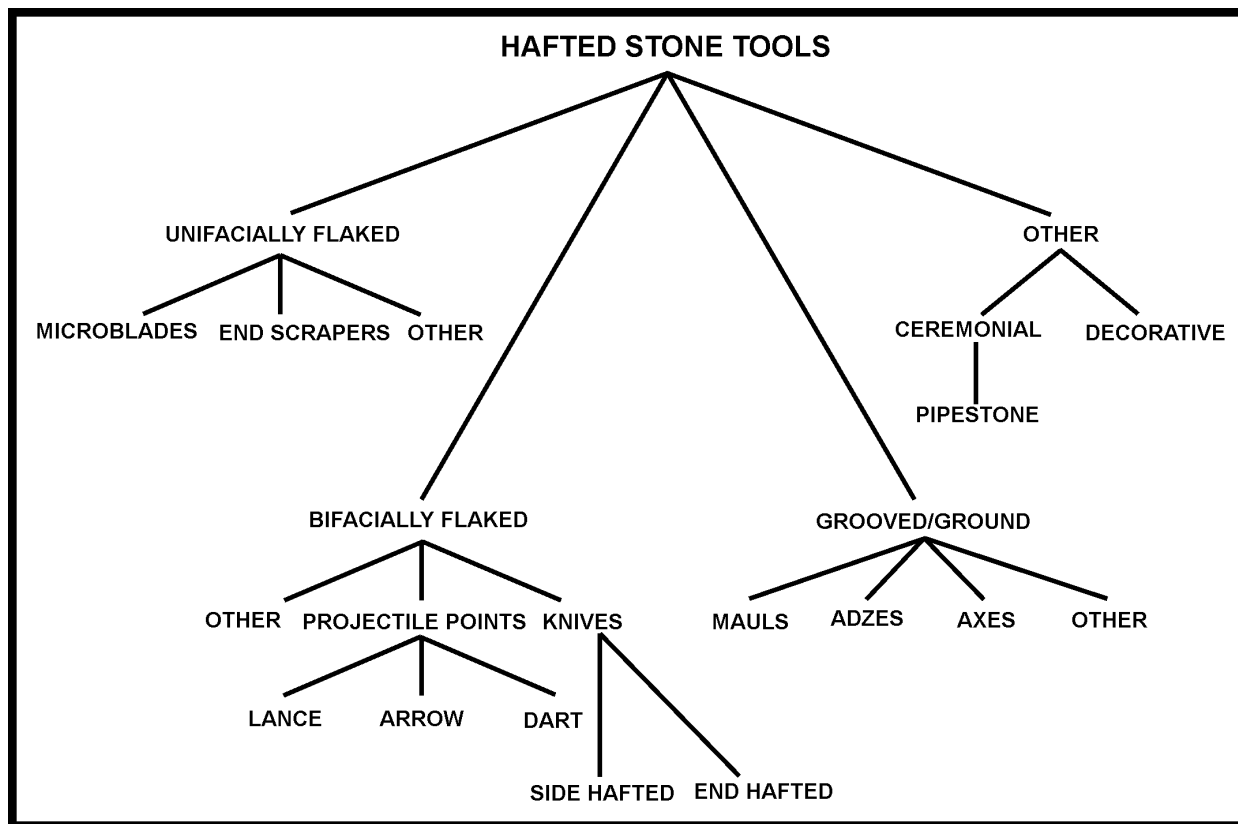

Figure 8: Categorization of hafted stone tools.

archaeologists will ultimately attain a better understand of hafting and the role it played in the technological organization of prehistoric peoples.

ACKNOWLEDGMENTS

This paper was developed out of an idea suggested by Jason LaBelle. Without his help and encouragement this paper would not have been written. Gayle Carlson, Mike Fosha, Kevin Gilmore, Larry Loendorf, Mark Stiger and James Truesdale were contacted and provided much information and guidance. Judith Cooper provided editing help and greatly improved the overall quality of this work. Thanks to the anonymous reviewer whose comments improved this paper immensely. Drawing on the resources and knowledge of the aforementioned individuals greatly enhanced the outcome of this work, but any inconsistencies, mistakes, or overlooked data are purely the fault of the author.

REFERENCES CITED

Aikens, C. M.
 1970 Hogup Cave. *University of Utah Anthropological Papers* 93.
 Andrefsky, Jr., William
 2005 *Lithics*. Cambridge University Press,

Cambridge.
 Bettinger, Robert L., and Jelmer Eerkens
 1999 Point Typologies, Cultural Transmission, and the Spread of Bow and Arrow Technology in the Prehistoric Great Basin. *American Antiquity* 64(2):231-242.
 Bozell, John R.
 1994 Late Precontact Village Farmers. *Nebraska History Magazine* 75(1):120-131.
 Browne, Jim
 1938 Antiquity of the Bow. *American Antiquity* 3(4):358-359.
 1940 Projectile Points. *American Antiquity* 5(3):209-213.
 Burgh, Robert F., and Charles R. Scoggin
 1948 *The Archaeology of Castle Park, Dinosaur National Monument*. University of Colorado Press, Boulder, Colorado.
 Butler, William B.
 1985 A Knife from Upper Plum Canyon Rockshelter I, Southeastern Colorado. *Plains Anthropologist* 30(107):51-57.
 Cosgrove, C. B.
 1947 Caves of the Upper Gila and Hueco Areas in New Mexico and Texas. *Papers of the*

- Peabody Museum of American Archaeology and Ethnology* 24(2).
- Cramer, Joseph L.
 1978 A Compound Arrow from Carbon County, Montana. *Archaeology in Montana* 19(3):131-136.
 2001 A hafted lithic knife from South-Central Montana – Survival in spite of the odds. *Archaeology in Montana*, 42(1):91-94.
- Davis, Carl M.
 1974 Wickiup Cave. *Plains Anthropologist* 20(70): 297-305.
- Fowler, Don D., and John F. Matley
 1979 Material Culture of the Numa: The John Wesley Powell Collection 1867-1880. *Smithsonian Contributions to Anthropology* 26.
- Frison, George C.
 1962 Wedding of the Waters Cave, 48HO301: A stratified site in the Big Horn Basin of Northern Wyoming. *Plains Anthropologist* 7(18): 246-265.
 1965 Spring Creek Cave, Wyoming. *American Antiquity* 31(1): 81-94.
 1968 Daugherty Cave, Wyoming. *Plains Anthropologist* 13(42): 253-295.
 1989 Experimental Use of Clovis Weaponry and Tools on African Elephants. *American Antiquity* 54(4):766-784.
 1991 *Prehistoric Hunters of the High Plains*. Academic Press, New York.
 2004 *Survival by Hunting: Prehistoric human predators and animal prey*. University of California Press, Berkeley, California.
- Gebhard, David, George Agogino, and Vance Haynes
 1964 Horned Owl Cave, Wyoming. *American Antiquity* 29(3): 360-368.
- Gunnerson, James H.
 1969 The Fremont Culture: A Study in Culture Dynamics on the Northern Anasazi Frontier (Including the Report of the Claflin-Emerson Expedition of the Peabody Museum). *Papers of the Peabody Museum of American Archaeology and Ethnology* 59(2).
- Harrington, Mark R.
 1933 Gypsum Cave, Nevada. *Southwest Museum Papers* 8.
- Hunzicker, David A.
 2005 Folsom Hafting Technology: An Experimental Archaeological Investigation into the Design, Effectiveness, Efficiency and Interpretation of Prehistoric Weaponry. M.S. Thesis, Department of Museum and Field Studies, University of Colorado, Boulder, Colorado.
- Jennings, Jesse
 1957 Danger Cave. *University of Utah Anthropological Papers* 27.
 1978 Prehistory of Utah and the Eastern Great Basin. *University of Utah Anthropological Papers* 98.
- Keeley, Lawrence H.
 1982 Hafting and Retooling: Effects on the Archaeological Record. *American Antiquity* 47(4):798-809.
- Loud, Llewellyn L., and Mark R. Harrington
 1929 Lovelock Cave. *University of California Publications in American Archaeology and Ethnology* 25(1):1-183.
- Mulloy, William T.
 1942 The Hagen Site: A Prehistoric Village on the Lower Yellowstone. *The University of Montana Publications in the Social Sciences* 1.
 1958 A Preliminary Historical Outline for the Northwestern Plains. *University of Wyoming Publications* 22(1):1-235.
- Nassaney, Michael S., and Kendra Pyle
 1999 The Adoption of the Bow and Arrow in Eastern North America: A View from Central Arkansas. *American Antiquity* 64(2):242-263.
- Nelson, Charles E.
 1970 Chamber Cave. *Southwestern Lore* 36(1):1-11.
- Nordenskiöld, Gustaf
 1978 *The Cliff Dwellers of the Mesa Verde*. The Rio Grande Press, Inc., Glorieta, New Mexico. (Reprint of 1893 edition)
- Oswalt, Wendell H.
 1976 *An Anthropological Analysis of Food-Getting Technology*. John Wiley & Sons, New York.
- Shott, Michael J.
 1997 Stones and Shafts Redux: The Metric Discrimination of Chipped-Stone Dart and Arrow Points. *American Antiquity* 62(1):86-101.
- Steward, Julian
 1937 Ancient Caves of the Great Salt Lake Region. *Bureau of American Ethnology Bulletin* 116.
- Stiger, Mark
 2001 *Hunter-Gatherer Archaeology of the Colorado High Country*. University of Colorado Press, Boulder, Colorado.
- Swanton, John R.
 1938 Historic Use of the Spear-Thrower in South-

eastern North America. *American Antiquity* 3(4):356-358.

Reno, Nevada.

Thomas, David H.

1978 Arrowheads and Atlatl Darts: How the Stones Got the Shaft. *America Antiquity* 43(3):461-472.

Cody Newton
Department of Anthropology
Colorado State University
Fort Collins, CO 80523
cnewton@lamar.colostate.edu

Weathermon, Rick L.

2005 *Atlatl Dart Refurbishing and Woodworking Technology at 39LA504, Crystal Cave, South Dakota*. Paper presented at the 63rd Annual Plains Conference, Edmonton, Alberta, Canada.

Wheeler, S. M.

1973 The Archaeology of Etna Cave, Lincoln County, Nevada. *Desert Research Institute Publications in the Social Sciences* No. 7,

WYOMING ARCHAEOLOGICAL FOUNDATION MEMORIAL GIFT or CONTRIBUTION FORM

Given by: Miss, Mrs., Mr., Ms., Dr. \$ _____
Amount

Name Last First Middle

Address City & State Zip

Donor phone number () ____ - ____ - _____

Type of Gift: _____

General Contribution [] Specific Contribution []

In Memory of: _____
Name City & State

In Honor of: _____
Name City & State

Specify where you would like your money to go _____
(e.g., Hell Gap Site Research, other, ????????)

Please make your check payable to THE WYOMING ARCHAEOLOGICAL FOUNDATION
Barbara Keiry, Secretary/Treasurer, P.O. Box 3146, Cody, Wyoming 82414 — 307-868-2685