

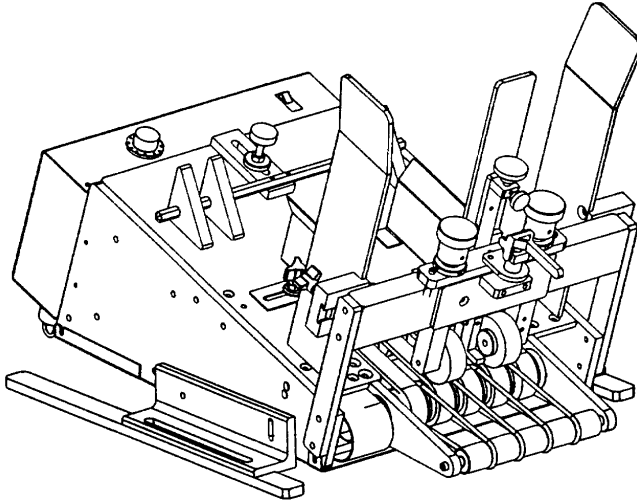

# KR496F Friction Feeder

Kirk-Rudy, Inc. • 125 Lorraine Parkway • Woodstock, GA 30188  
Phone: (770) 427-4203 • Fax: (770) 427-4036



## FEATURES

- \*Easily feeds difficult items such as Z-Folds and Open-ends.
- \*Portable design. Easily mounts onto KR215IJ Feed Base and KR219IJF Base.
- \*Can be equipped for batch counting and mark reading modes.
- \*Rugged construction.

## OPTIONS

- \* High Speed Servo Drive
- \* Clutched DC Drive
- \* Double Detect
- \* Bridge Width Extensions  
14,16,18,24 inch.

## SPECIFICATIONS

<b>Dimensions:</b>	Length:	23 IN	584 MM
	Width:	12.8 IN	325 MM
	Height:	17.5 IN	445 MM

**Power Requirements:** Electrical 120 VAC, 2.0 AMPS, 50/60 HZ

**Belt Speed:** Variable to 800 FT/MIN

<b>Product Capacity:</b>	Width:	Minimum	3 IN.	76 MM
		Maximum	11 IN.	282 MM
	Length	Minimum	4 IN.	101 MM
		Maximum	12 IN.	305 MM
	Thickness:	Minimum	0.004 IN	0.10 MM
		Maximum	0.188 IN	4.78 MM

**Kirk-Rudy, Inc.,** 125 Lorraine Parkway, Woodstock, GA 30188