

THERMAL CUTOUT REPLACEMENT

ALL EXTRACTORS, ULTIMATE & XLT-60

1. Using a razor blade, cut along the side of the thermal cutout (hump under the tape).

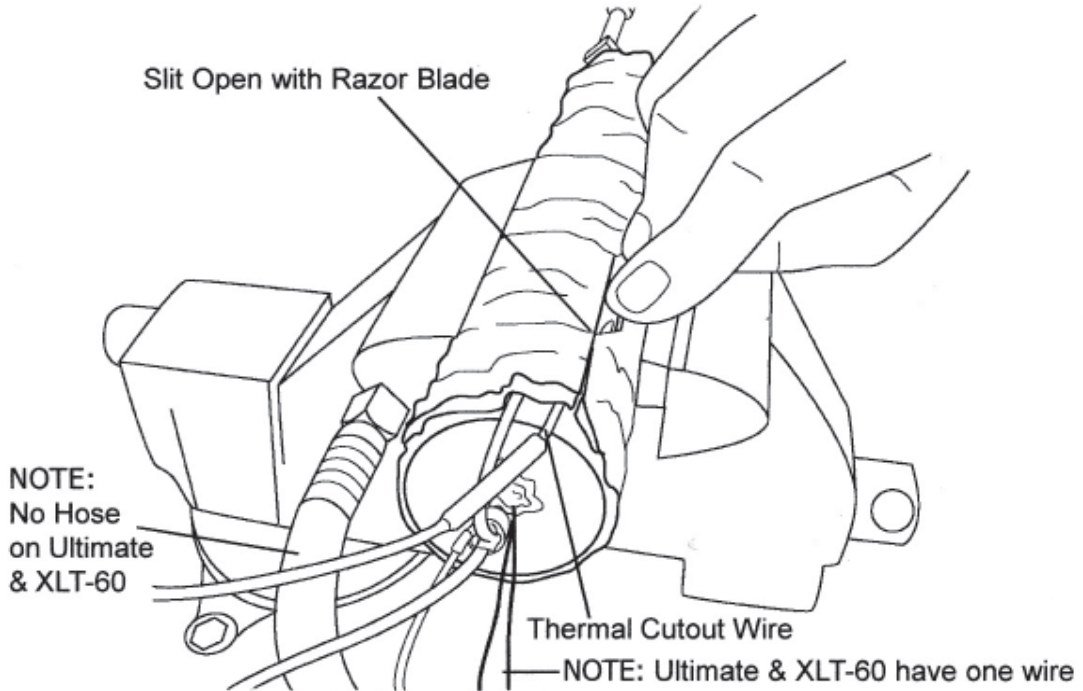

2. Peel the tape and insulation back, exposing the thermal cutout.

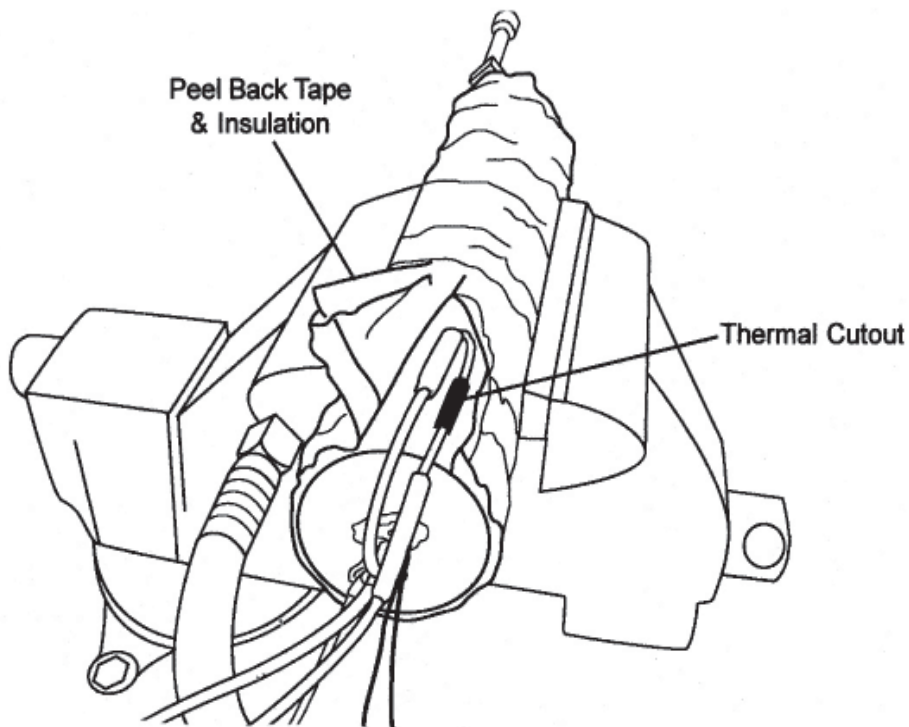

3. Cut the heater element lead, as illustrated. **NOTE:** cut as close as possible to the connector under the heat shrink. Pull the thermal cutout out of the way. Leave the black tape that lies on the heater under the cutout in place.

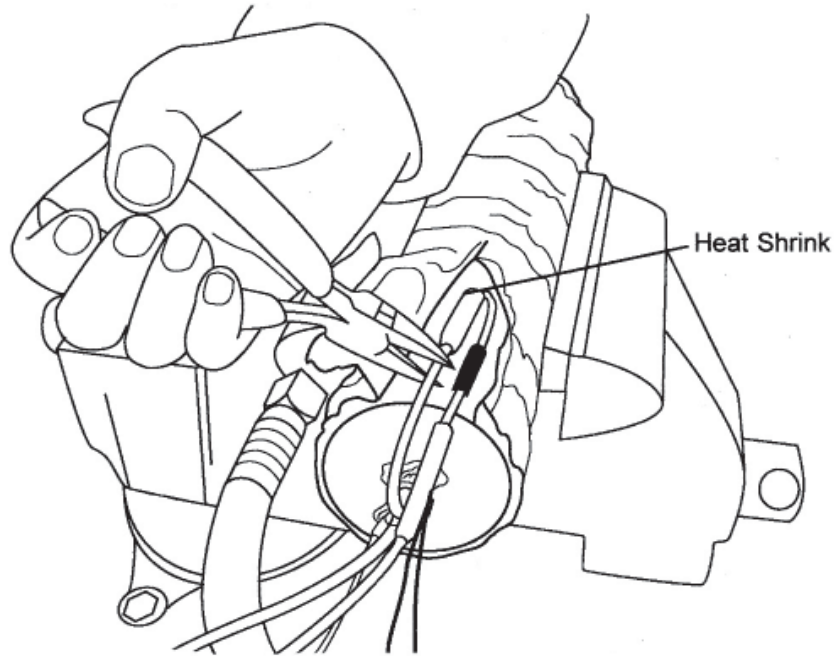

4. Remove 3/16" to 1/4" of the clear insulation without damaging the heavy, solid wire.

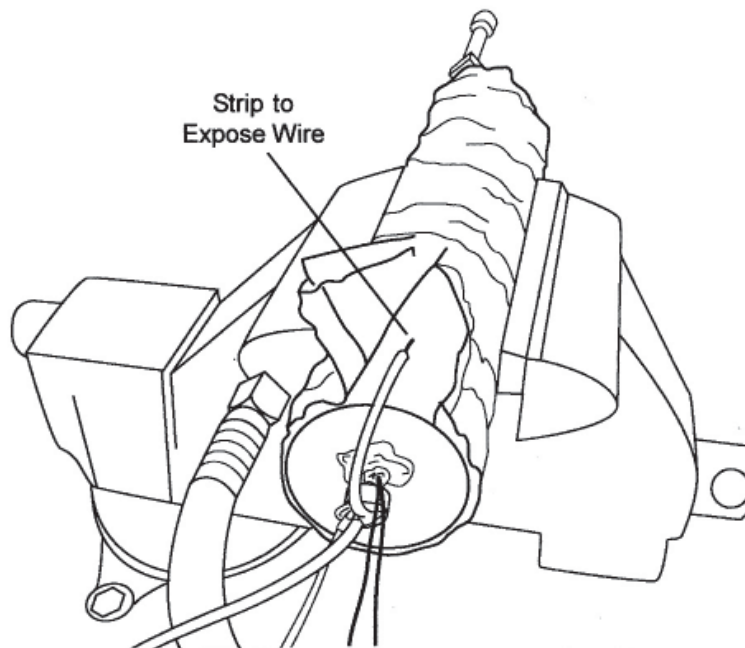

5. Position the new thermal cutout onto wire (slide shrink tubing out of the way). Crimp connector onto the heater element wire. Make as tight a metal-to-metal connection as possible.

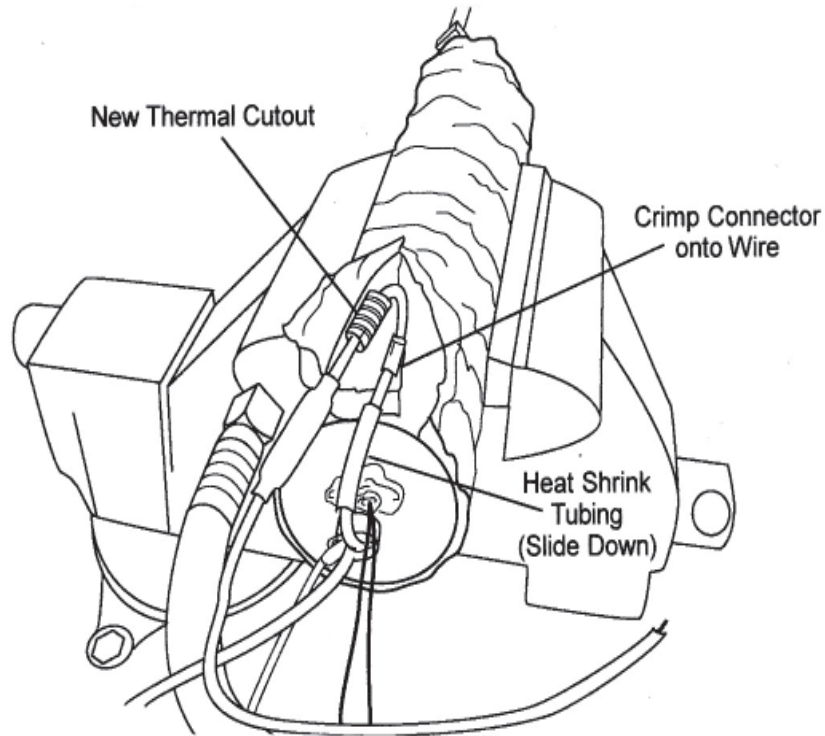

6. Slide heat shrink over the area just connected and shrink into position using a heat gun or hair dryer. **NOTE:** Protect the device from getting hot.

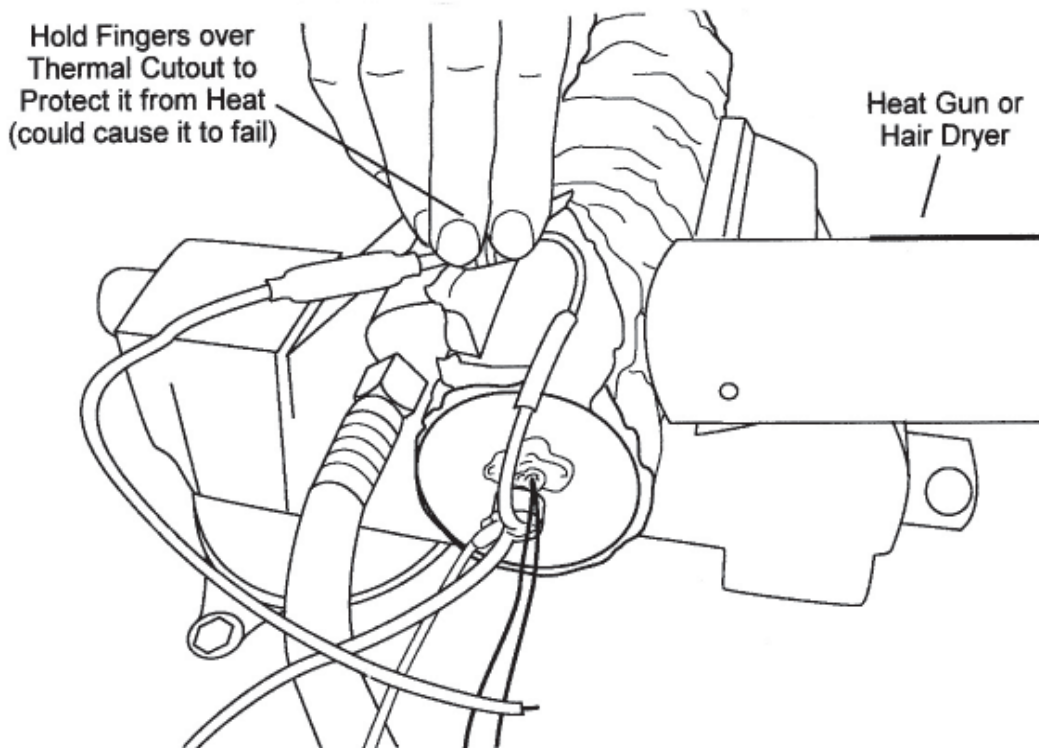

7. Lay the thermal cutout into position as per drawing. The assembly is already bent. Try not to bend it differently. **NOTE:** Cutout should lie on top of black tape.

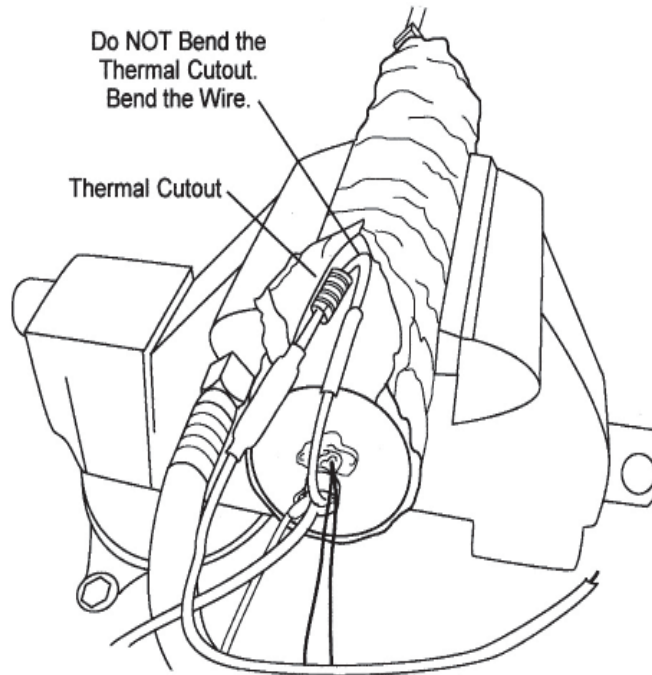

8. Fold the insulation back over the new thermal cutout. Using the special high temperature tape supplied with the repair kit, close up the cut area as per drawing.

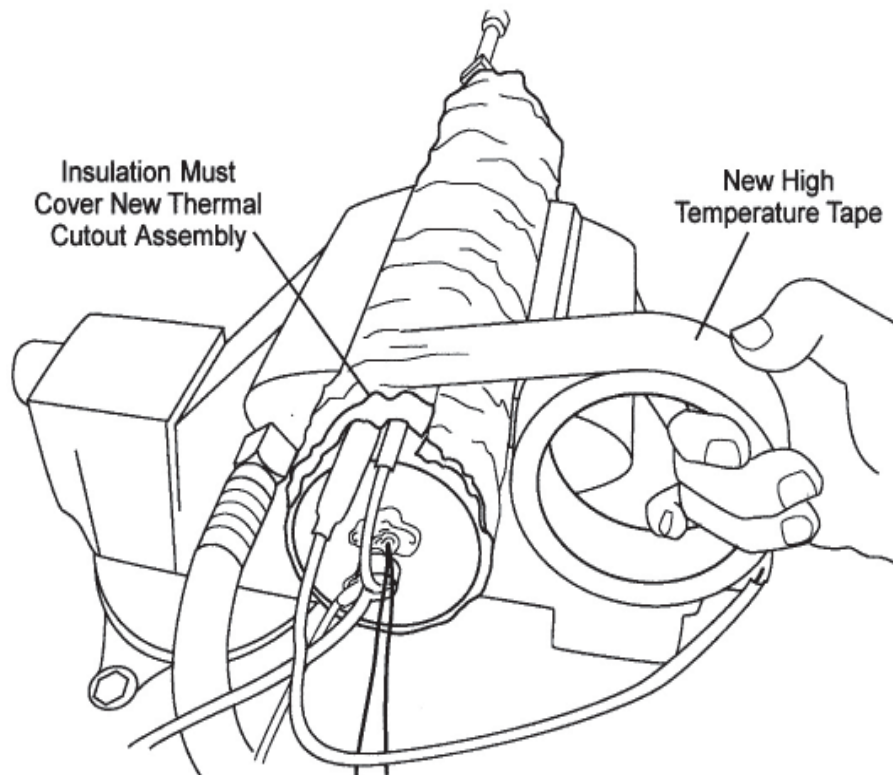

9. Connect all heater wires to the appropriate locations. Refer to the wiring diagram for your machine.