

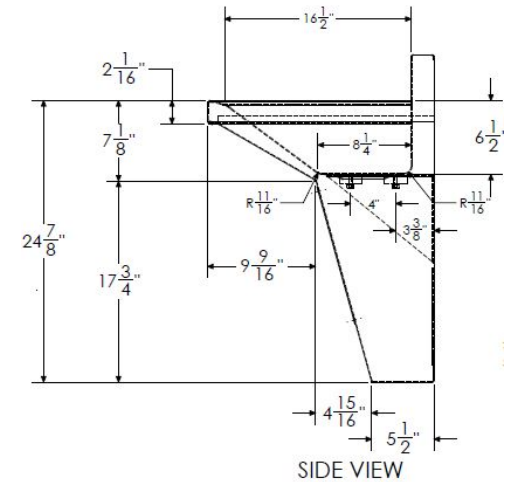

WICKETTS STAINLESS SPECIFICATION

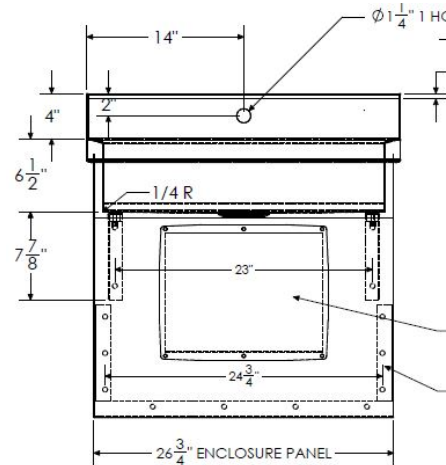
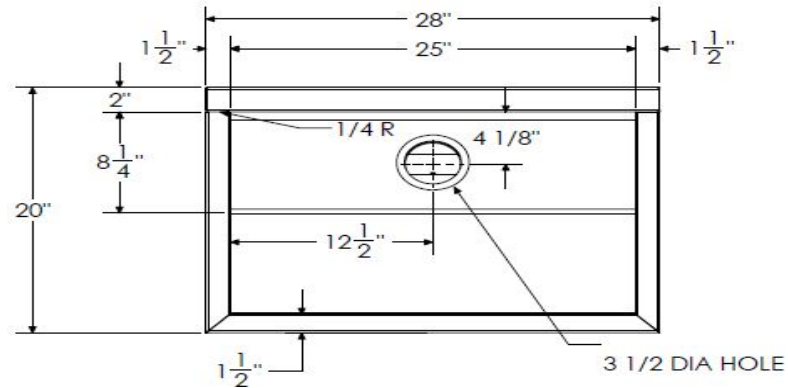
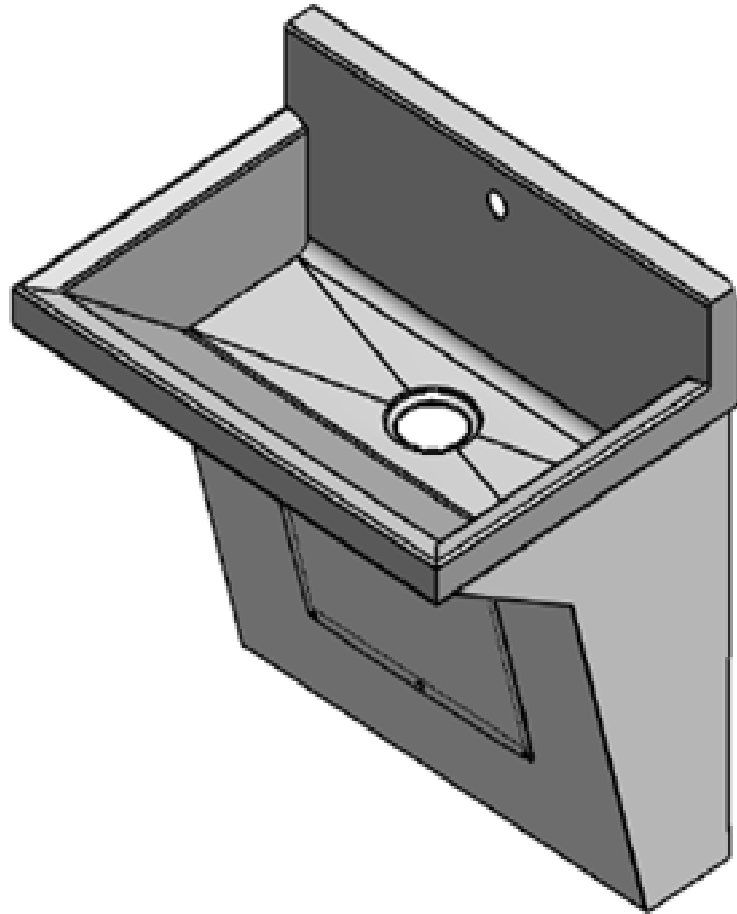

REMOVABLE ACCESS COVER

16GA STAINLESS STEEL ENCLOSURE
PANEL WITH REMOVABLE ACCESS
COVER

Wicketts Stainless, LLC.
2618 San Miguel Dr. Bldg. # 376
Newport Beach, CA 92660
Tel: 951-858-2548
Fax: 951-638-9059
sales@wickettsstainless.com
www.wickettsstainless.com



WARNING:
This product can expose you to chemicals,
which are known to the State of California to
cause cancer. For more information, visit
www.P65Warnings.ca.gov.



Approved for Manufacturing
Company _____
Signature _____

NON- CANCELABLE NON- RETURNABLE