

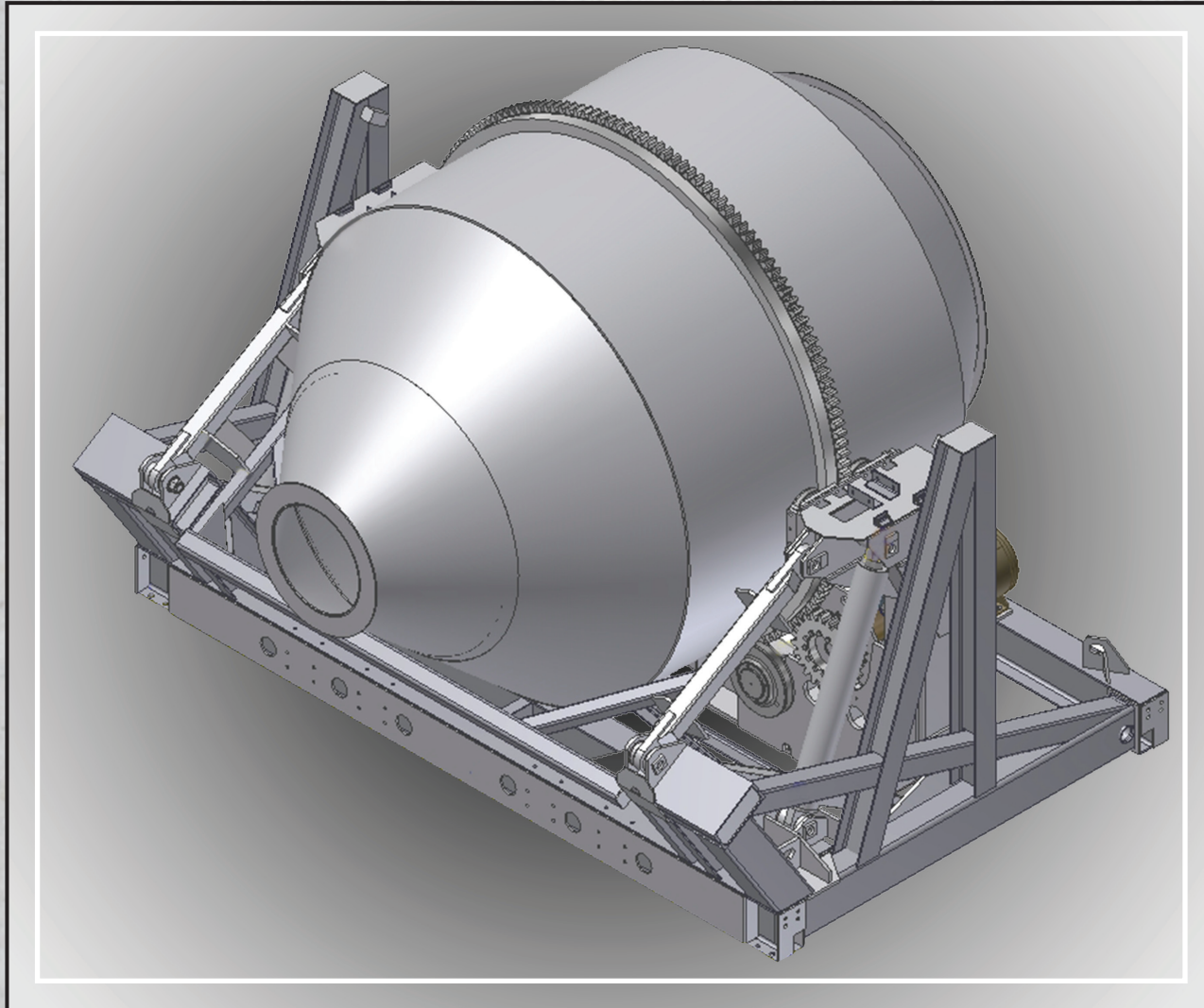

Rugged. Reliable. Respected.

Erie Strayer Company has provided a standard of excellence in over 1,000 installations throughout the world. Continuing research and development places ERIE at the forefront of technological advances. For ready mix to highway paving, for dam to other specialty applications, the ERIE mixer is the best in the business.



CONCRETE TILTING MIXER



Rugged. Reliable. Respected.

- 4.5 THROUGH 15 CUBIC YARDS
- SUPERIOR MIXING ACTION
- UNIQUE TILTING CYCLE REDUCES OVERALL HEIGHT
- PLANETARY GEAR DRIVE
- ADJUSTABLE BOLT-ON MAIN & EDGE ROLLER ASSEMBLIES
- ADVANCED DIGITAL HYDRAULIC CONTROLS

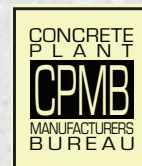

www.eriestrayer.com

814.456.7001

sales@eriestrayer.com

www.eriestrayer.com

814.456.7001

sales@eriestrayer.com

INDUSTRY LEADING DESIGN... MOST DURABLE CONSTRUCTION



ERIE has been a pioneer and innovator in the development of central mix concrete. The current model of the ERIE Tilt Mixer represents the experience gained through thousands of installations in a wide variety of demanding applications. ERIE mixers across the world have produced billions of yards of concrete, from conventional concrete to more unique and challenging mixes like cement treated base, roller compacted concrete, no slump, low slump, shotcrete, pervious, high strength and ultra-high strength mixes. No matter the application, ERIE mixers will produce a quality mix and get the job done.

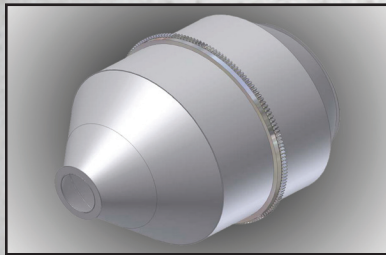

The ERIE drum shell is made up of 3/4" steel for the center cylinder and 3/8" steel for the charge and discharge end cones. During manufacture, the drum cylinder is rolled to a round tolerance of $\pm .031$ ". The end cones are shaped on a press brake using the same tight specification of $\pm .031$ ". The fit up of the charge and discharge cones to the drum cylinder is closely monitored at all stages. Only when careful O/C inspections have been approved, are the final welds of the cones to the cylinder completed. This rigid adherence to tight manufacturing specifications helps insure a close fit of the bull gear to the drum shell and helps insure the extremely long life found in an ERIE mixer.

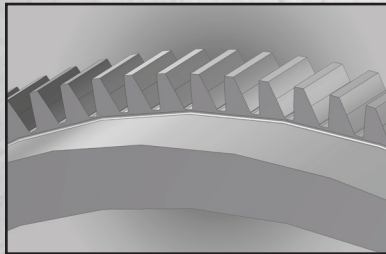

The bull gear, made of a single-piece, 1045 steel, forged ring, holds the same tight specifications of $\pm .031$ " and provides both the teeth that the pinion gears will drive and the track the main rollers and edge roller assemblies will ride on. The gear teeth are machine cut - a process ERIE firmly believes is superior to the flame cut teeth in general use today. This accounts for the near perfect mesh achieved between the pinions and bull gear. The bull gear is continuously welded to the drum shell by an automated MIG welding process. The weld is then tested using an ultrasonic process to detect any subsurface cracks. This procedure insures a secure, tight fit so that the bull gear remains in place for many years of rigorous use.

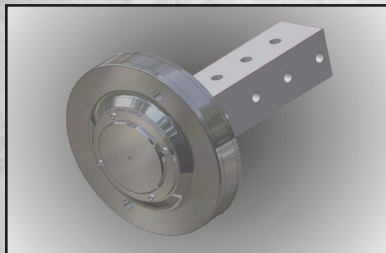

The ERIE mixer drum is supported by two main rollers. Each roller is made of 4140 steel, annealed for wear hardening and machined to a close tolerance of $\pm .002$ ". The rollers are factory mounted on a machined shaft. Timken taper roller bearings insure long life and low maintenance. The entire assembly is factory installed onto the mixer main frame using 7 high strength bolts and shimmed to exact alignment with the roller track of the bull ring.

ADVANCED OPTIONS

- POLYURETHANE DRUM AND BLADE LINERS
- WRAP AROUND POLYURETHANE BLADE LINERS
- MIXER MAINTENANCE PLATFORMS
- PORTABLE TRAILER
- DC POWERED EMERGENCY TILT SYSTEM
- DRIP PAN AND TELESCOPIC BOOT

THE ERIE DUAL OPENING TILT MIXER RAISES THE BAR IN CONCRETE MIXING THROUGHOUT THE WORLD

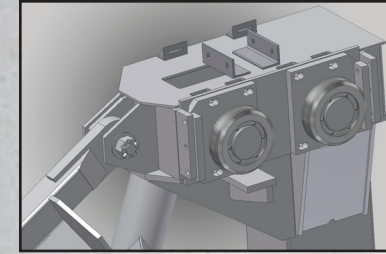

The mixer drum is maintained in proper vertical alignment by three sets of bolt-on, fully adjustable edge roller assemblies factory installed at the 3, 6, and 9 o'clock positions. Each assembly consists of two rollers mounted on steel pads with slotted adjustment holes. The rollers are made of 4140 alloy steel, annealed for wear hardening and machined to the same $\pm .002$ " tolerance found on the main rollers. During factory installation of the drum, careful, precise adjustments to the vertical alignment insure a near perfect mating of the main rollers and pinion gears to the bull ring track and teeth. This precision results in extended life of the roller and gear assemblies on the ERIE mixer.

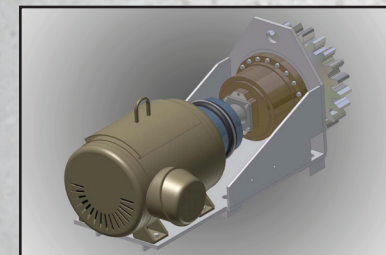

A key feature found in ERIE mixers is the use of planetary gear reducers. Two reducer assemblies are used to drive the drum. The planetary reducers feature easy access to all gearing. The pinion gears are bolted directly to the front of the reducer. Each pinion gear is made of 4320 steel with carburized, hardened and crowned teeth. The "unibase" design of the complete assembly features an L-shaped bracket to which the reducer is bolted and which supports the motor. The motor is connected to the reducer using a flexible coupling.



Tilting of the ERIE drum is accomplished by a state-of-the-art hydraulic system. This system consists of a variable volume pump, proportional directional valve, pressure sensing relief valve, two all-welded tilt cylinders and over-center valves on the base of each tilt cylinder to provide anti-drop protection for the system in the event of a ruptured hydraulic line. Absolute speed control of the tilt time is controlled by the operator at the control console.

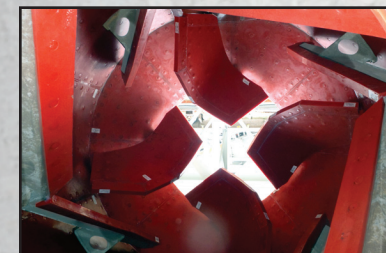

At the heart of the ERIE mixer are four buckets and four blades uniquely manufactured and positioned to provide the most thorough mixing action found in a drum mixer today. As water, aggregate and cement are charged into the drum, the four blades work to pull the materials forward. The four buckets then act to plow the materials back. As the drum turns, the aggregate, water and cement are continuously folded back together to provide a complete uniform coating of the cement paste to the aggregates. The mixing action is, in fact, so complete and thorough that the ERIE mixer has been approved for specification mix times in as little as 30 seconds.

ADVANCED OPTIONS

- CENTRAL GREASE STATION FOR ALL PINS AND BEARINGS
- HYDRAULIC HEATING AND COOLING SYSTEMS
- AUTOMATIC LUBRICATION SYSTEM FOR MIXER BULL GEAR
- HIGH SPEED, 60 HP "PAVING" HYDRAULIC SYSTEM