

Instrument Panel Outer Trim Cover Replacement

Removal Procedure

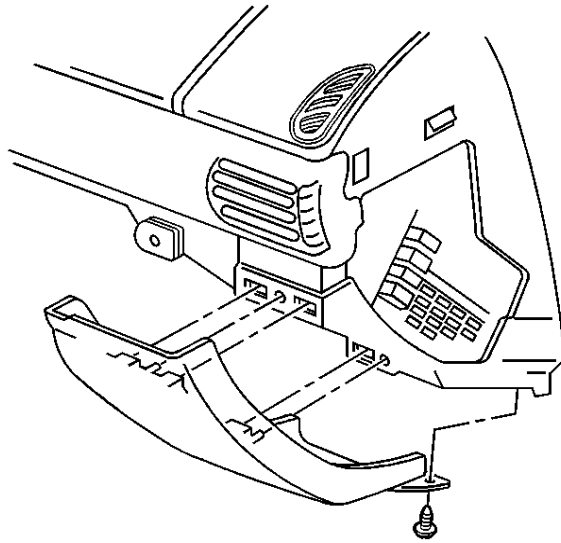

1. Open the instrument panel (I/P) compartment door.
2. Remove the filler panel bolt.

3. Starting at the top of the filler panel, pull rearward to release the top retainer.

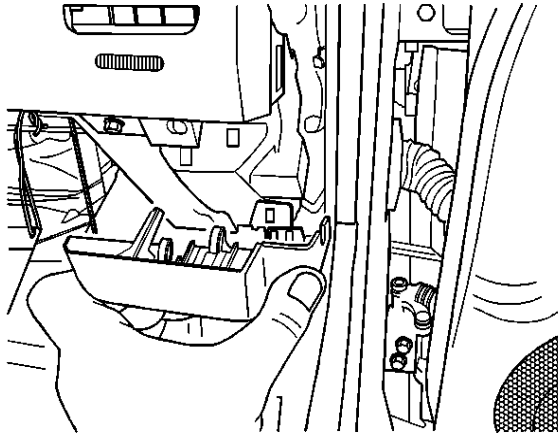

4. Pull the center of the filler panel rearward to release the middle retainer.
5. Pull the bottom of the filler panel straight out to release the final retainer.
6. Remove the filler panel.

[Installation Procedure](#)

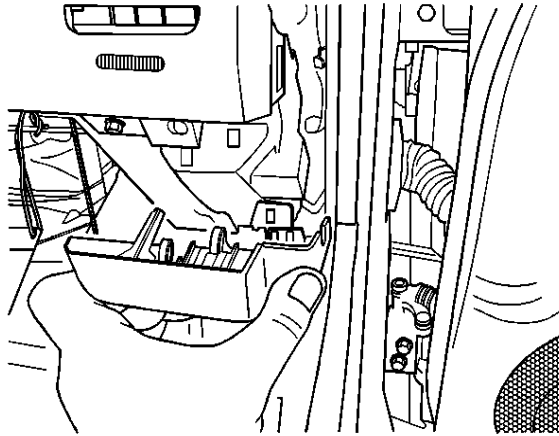

1. Position the filler panel retainers into the openings in the trim pad.
2. Starting at the bottom, install the filler panel by pressing in at each retainer location until correctly seated.

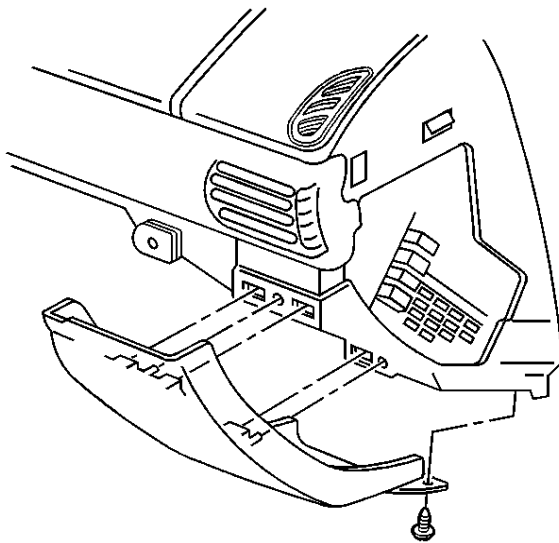

Notice: Use the correct fastener in the correct location. Replacement fasteners must be the correct part number for that application. Fasteners requiring replacement or fasteners requiring the use of thread locking compound or sealant are identified in the service procedure. Do not use

paints, lubricants, or corrosion inhibitors on fasteners or fastener joint surfaces unless specified. These coatings affect fastener torque and joint clamping force and may damage the fastener. Use the correct tightening sequence and specifications when installing fasteners in order to avoid damage to parts and systems.

3. Install the filler panel bolt.

Tighten

Tighten the bolt to 2 N·m (18 lb in).

4. Close the I/P compartment.

www.fixmygauges.com