



Application for a New Zealand Passport

Uruwhenua Aotearoa

Adult

USE THIS FORM if you are 16 years or over and are applying for a New Zealand Passport and:

- ▶ you are applying for the first time **OR**
- ▶ you are renewing your passport and your name has changed since your previous passport was issued **OR**
- ▶ you are renewing your passport because your previous passport is lost or stolen.

Use the Adult Renewal form if you are 16 years or over, and your name has not changed since your previous passport was issued and your previous passport is not lost or stolen.

Our New Zealand Passport

Our passport is valued and respected around the world for its integrity. We ask you to provide a range of information so that we can maintain its integrity by confirming your identity and entitlement to a New Zealand Passport.

The New Zealand Passport is valid for a maximum period of 5 years. The validity period starts from the date of issue and runs until the date of expiry.



This icon is used when you need to take extra care. The instructions with this icon will help you to understand whether you need to complete a particular section, or remind you not to miss out important details.

What you need to complete this application

- ▶ Two (2) identical recent colour photos of yourself
- ▶ Someone to act as a witness who is over 16 years of age and has a valid New Zealand Passport
- ▶ The correct application fee

Sending original documents

Sometimes we may ask you to send us original documents. In most cases, we only need original documents if they have been issued outside New Zealand.



We will make it clear using this icon when you need to send us an original document.

How to contact us

New Zealand: Freephone 0800 22 50 50
Phone +64 4 474 8100 Fax +64 4 382 3410

Australia: Freephone 1300 559 535
Phone +61 2 9225 2300 Fax +61 2 9223 0223

United Kingdom: Phone +44 20 7968 2730 Fax +44 20 7968 2739

Website: www.passports.govt.nz Email: passports@dia.govt.nz



Please call our helpline if you need any assistance to complete this form

How to complete this application form

Use this guide section to help you to fill in the form. The numbers in this guide will take you through each step in the form.



READ ALL INSTRUCTIONS CAREFULLY

Fill in this form yourself. You must use your own handwriting. If you cannot fill in this form yourself because you have a disability or a language difficulty, someone else can fill in the form for you. This person must complete the statutory declaration (in section **8**).

Check you have answered all the questions on this form related to you. We can only process your application if you complete the form accurately. If you miss out any details we may need to contact you and there may be a delay in the processing of your application.

This application form will be scanned and processed using computer software. We ask you to follow the instructions below to improve the accuracy and efficiency of our scanning and data capture.

► Use a black or blue ballpoint pen and complete in your own handwriting.

► Write in CAPITAL letters inside each box like this

A	B	C
---	---	---

1	2	3
---	---	---

, NOT like this

a	q	C
---	---	---

7	8	6
---	---	---

► Tick options inside the boxes like this , NOT like this

► Put a line through mistakes like this

A	B	C
--------------	--------------	--------------

. DO NOT use correction fluid or correction paper.

1 Your personal details

Names

Write the name you want to appear in your passport. This name must be a name that is officially registered; for example, a name by birth, marriage, civil union or name changed by statutory declaration or deed poll. Do not use nicknames or names that you are "commonly known as".

- Surname or family name is sometimes known as your last name
- First and middle names are also known as given names. These are any names you have apart from your surname
- If you only have one name, write it in the space provided for surname or family name.

Height and eye colour

Fill in your height and eye colour. This is important information. We can't process your application without it.

- Fill in your height using centimetres
- Choose an eye colour that is closest to yours. Try to use a common colour that is closest to your own, such as brown, blue, green, grey, hazel or black.

2 Your entitlement to a New Zealand Passport

Only New Zealand citizens are entitled to a New Zealand Passport. The information you give us will help us confirm that you are a New Zealand citizen.

Born in New Zealand

If you were born in New Zealand tick this option to indicate your entitlement.

Born in Niue, the Cook Islands or Tokelau

If you were born in Niue, the Cook Islands or Tokelau, you are entitled to a New Zealand Passport. You will need to send us your original birth certificate if you are applying for a passport for the first time, or if your name has changed since your previous passport was issued, or if your previous passport has been lost or stolen.

New Zealand citizenship by grant or descent

If you were born outside New Zealand and have obtained New Zealand citizenship either by grant or by descent, fill in your name and citizenship certificate number in the spaces provided.

If you believe you are entitled to citizenship but have not obtained a citizenship certificate, you will need to contact the Citizenship Office (You must determine your citizenship status through the New Zealand Citizenship Office before we can issue you with a New Zealand Passport).

Entitlement for another reason

If you believe you are entitled to a New Zealand Passport for any other reason, please send us documents to support your claim.

3 Names at birth

To confirm that you are entitled to a New Zealand Passport, we need to know your name at birth. We also need to know your parents' names that appear on your birth certificate and your mother's name at her birth.

If you were legally adopted, write the names that you were given after adoption.

4 Your contact and delivery details

Your home address

This is the place where you are currently living. Do not give a box or bag number, or a 'care of' (c/-) address.

Your contact details

We need your contact details in case we have questions about your application. Write in phone numbers, email address or a fax number, so we can contact you.

Your delivery address

- If you want your passport delivered to a home address in New Zealand, you will need to have someone at home to sign for it. If there is no one at home to sign for it, you will need to organise a redelivery
- If you want your passport delivered to a business, tell us the name and the address of the business
- If you want your passport delivered by international courier you must provide a street address, not a Post Box number.

► Example of how to enter your phone number:

+

COUNTRY CODE AREA CODE PHONE NUMBER

5 Your previous New Zealand Passport or other New Zealand travel document

If you have ever had a New Zealand Passport or other New Zealand travel document, you must fill in this section.

New Zealand Passport

You are not required to send your previous New Zealand Passport in with your application.

WARNING Once your passport application has been received, your old passport will be cancelled immediately and cannot be used for travel. Anyone attempting to travel on a cancelled passport will be refused travel.

Other New Zealand travel document

You are required to send us your previous New Zealand Refugee Travel Document, Certificate of Identity or Emergency Travel Document, with your application whether it is expired or not. This travel document will be cancelled and retained by the Passport Office.

If your document has been lost or stolen, fill in section **9**.

6 Name change by marriage or civil union

If you have changed your name by marriage or civil union and you want this name to appear in your passport, you must fill in this section.

We need details of all your marriages or civil unions. Fill in the form starting with the most recent. The form

has space for your two most recent marriages or civil unions. If you have had more than two marriages or civil unions, write the details on a separate piece of paper and send it with this application form.

If any of these marriages or civil unions took place **outside New Zealand**, send the original certificates to us with this application form.

7 Name change by statutory declaration or deed poll

If you have ever changed your name by statutory declaration or deed poll, you must fill in this section.

Begin by filling in your most recent name change. If you have changed your name more than twice, write the details on a separate piece of paper and send it with this application form.

For any name changes made **outside New Zealand**, you need to send us the original documents with this application form.

If you were born overseas, you need to send us original name change documents for any name change registered in New Zealand before 25 January 2009.

8 Statutory Declaration

What is a statutory declaration?

A statutory declaration is a written statement declaring something to be true in the presence of an authorised witness.

Will I need to complete this section?

Filling this application in yourself

If you are filling in this application yourself, complete the statutory declaration only if any of the following apply to you:

- you are wearing a head covering or headband in your passport photos for medical or religious reasons
- you wish to provide additional information, or an explanation, about your application
- the Department of Internal Affairs has requested that you provide additional information.

Tick the declaration statement that applies to you.

Enter your name, residential address and contact details.

Provide additional information as necessary.

You will need to find an **authorised witness** before you sign and date the declaration.

Filling in this application for someone else

If you are filling in this application for someone else, you need to complete the statutory declaration.

You will need to explain why the applicant cannot complete the form themselves.

You can only fill in this form for someone else if that person has a disability or a language difficulty preventing them from completing the form.

Tick the declaration statement "I have completed this form for someone else aged 16 years or over because they have a disability or language difficulty".

Tick any of the other declaration statements that relate to the applicant:

- the applicant is wearing a head covering or headband in their passport photos for medical or religious reasons

- the applicant wishes to provide additional information, or an explanation, about their application
- the applicant needs to provide additional information to the Department of Internal Affairs.

Enter your name, residential address and contact details in this section (not those of the person applying for the passport).

You, the person filling in the form for the applicant, will need to find an **authorised witness** before you sign and date the declaration.

Who can be an authorised witness for a statutory declaration?

The witness for a statutory declaration must be one of the following:

- a Justice of the Peace
- a Member of Parliament
- a Solicitor
- a Registered Legal Executive (Fellow of NZILE)
- a Government Officer authorised to take statutory declarations.

When you have found a witness, you will need to make an appointment with them and take your application form with you.

You must sign and date the statutory declaration section in front of the witness, and then the witness must sign to confirm that you have signed the declaration in front of them.

9 Declaration for a lost or stolen New Zealand Passport, or other New Zealand travel document

Fill in this section only if your most recent previous passport or travel document has been lost or stolen.

If your passport or travel document has been lost or stolen in New Zealand, you must advise the Department of Internal Affairs immediately and report the loss or theft to the police. You will need to obtain a police report and send it to us with this application form.

If your passport or travel document has been lost or stolen outside New Zealand, then contact your nearest New Zealand Passport Office or New Zealand Embassy, High Commission or Consulate, and report the loss or theft to local police. You will need to obtain either a local police report, a Crime Reference Number (UK), Police Report Event Number (Australia), or a local police equivalent for other countries.

If you require a replacement passport, complete this application form, including the Declaration for a lost or stolen passport or other travel document.

If you were born in Niue, the Cook Islands or Tokelau, you will need to send us your original birth certificate to obtain a new passport.

The loss or theft of a passport or travel document is a serious matter. If your passport or travel document has been lost or stolen, processing may take longer as we may need to make further enquiries.

10 Your emergency contact

Give us the name and contact details of a person who can be contacted in emergency situations.

If you have an accident, become sick, or are involved in an incident while you are travelling overseas, we can contact someone on your behalf. We recommend that you nominate a person who is not likely to be travelling with you.

11 Your Applicant Declaration

You must sign this declaration if:

- you have filled in your application form yourself
- you can sign your own name but someone else has filled in the application form for you.

If you cannot sign your own name, then the person who filled in the application form for you should complete and sign the statutory declaration. In this case, leave this section unsigned.

12 Your name for the witness to confirm

Write your name in your own handwriting, as it appears in section 1 of this form. We need you to write your own name again in this section so that your witness can confirm in the section below that you are the person named above and the person whose photo they have named, signed and dated.

13 Witness section

 Please get your witness to read this section of the Guide Notes before they fill in section 13.

Your witness

Your witness must fill in this section in their own handwriting and write your name on the back of one photo and sign and date the back of the photo.

Who can be your witness?

Your witness must:

- have a valid New Zealand Passport
- have known you for 1 year or more
- be 16 years of age or older
- not be related to you; for example, your witness cannot be your parent, child, brother, sister, aunt, uncle or cousin
- not be your spouse or partner
- not live at the same address as you.

Your witness needs to provide their passport number, name, date of birth and contact details, including a day-time phone number.

Your witness writes on the back of one photo

Your witness must write **your** full name, their own signature and the date on the back of one photo. A business that takes passport photos will usually supply one photo with a pre-printed label on the back.

Witness declaration

Your witness must sign the declaration and date it to show they understand their obligations under the law.

Photos – getting passport quality photos

Provide two identical colour photos that are less than 6 months old and send with this application.

New technology has been introduced to scan your photos and ensure that they meet international travel standards. We strongly recommend that you obtain your photos from a business that provides a passport photo service, as the business will help ensure that your photos meet our requirements.

Photographs that do not meet our requirements will NOT be accepted and this will delay the issue of your new passport.

To help you avoid some of the most common problems with photo quality, we have summarised the main requirements below and provided some sample photos.

If you need more detailed information about photos, visit our website www.passports.govt.nz or phone us at the contact numbers listed on the front cover of these Guide Notes.

Photographic image requirements

Photo age

- photos must be less than 6 months old.

Photo size

- standard size 35mm x 45mm.

Head size

- head, including hair, should fit within the oval shown in the template below
- maximum size of head, including hair, must be 80% of photo
- head must be centred, with a clear gap around the sides and top of the head, including hair.

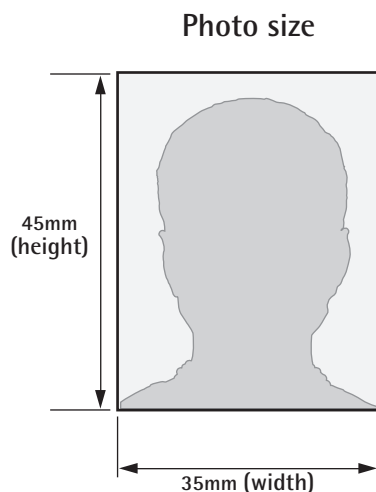

Paper quality

- use high quality, high resolution photo paper
- you can also use colour film or low gloss coated thermal papers as long as the printer is high resolution
- DO NOT use matt paper, heavy-backed thermal paper or an ink-jet printer.

Photo quality

- photo must be a true image, not altered in any way
- photo must be in focus, with no red-eye and little reflected light on the face.

Background

- the background must be plain and light, but not white
- there must be strong contrast between image and background, with no shadows.

Pose

- face the camera straight on, with your head straight, eyes open and mouth closed
- maintain a neutral expression, not smiling or frowning
- ensure you have no hair across your face or eyes as eyes must be clearly visible.

Glasses

- eyes must be clearly showing through glasses, with no reflection
- remove glasses with heavy-rimmed frames
- do not wear sunglasses, or glasses with tinted lenses that obscure your eyes.

Head covering or headband

- no head covering or headband should be worn in the photo, unless you must wear either for religious or medical reasons, in which case you must complete the statutory declaration at section 8 of the form.

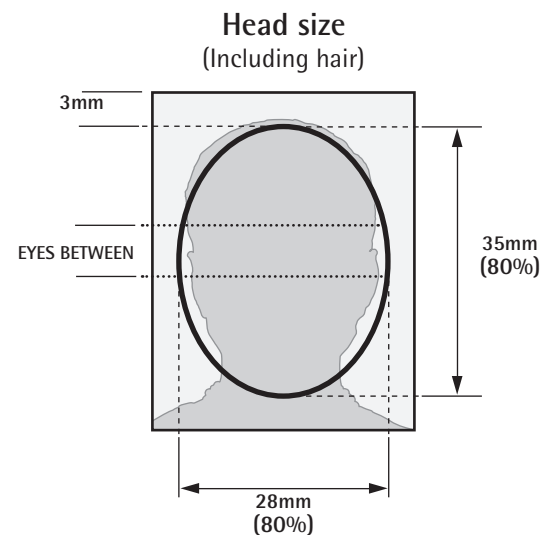

Photographic image requirements – examples

Please note that these example photos are not actual size.

Head size and facial expression

Acceptable



Unacceptable



Head too big



Expression not neutral

Glasses, head covering, scarves and hair

Acceptable



Unacceptable



Frames too heavy



Frames obscuring eyes

Acceptable



Unacceptable



Light reflection on lenses



Tinted lenses obscuring eyes

Acceptable



Unacceptable



Scarf covering chin/edges of face



Face partially covered by head covering

Contrast and lighting

Acceptable



Unacceptable



Shadows on background



Contrast too dark

14 Application fees and payment

Choosing a level of service

When we have all the information we need and the correct payment, we will process your application within the following service times.

Standard service: up to 10 working days

Urgent service: up to 3 working days

Callout service: outside business hours by appointment only

Remember to add on delivery time to and from the Passport Office for Standard and Urgent service.

Urgent service

There is an extra fee for using the Urgent service.

If you are using the Urgent service because yours travel is for bereavement or serious illness, you may not have to pay the extra fee or we may refund the extra fee. Send us a letter (in English) from a doctor, hospital or the police to explain the circumstances.

Callout service

There is an additional fee for using the Callout service.

This service is available by appointment outside business hours, 7 days a week, for emergency situations. Contact us for more information.

New Zealand: Freephone 0800 22 50 50

Australia: Freephone 1300 559 535

United Kingdom: +44 20 7968 2730

Cost of your application and courier fees

To find out the cost of application fees and courier fees, refer to the fees information available at www.passports.govt.nz or phone one of the following numbers:

New Zealand:

Freephone 0800 22 50 50 within New Zealand
+64 4 474 8100 from overseas

Australia:

Freephone 1300 559 535 within Australia
+61 2 9225 2300 from overseas

United Kingdom:

+44 20 7968 2730

How to pay

Your application fee must be paid in the currency of the country where you are sending your application to be processed.

If you apply by mail you can pay your fee by credit card, debit card (UK only), cheque or money order. **DO NOT POST CASH.**

If you apply in person at a Passport Office counter, you can also pay by cash or EFTPOS.

If you pay by cheque or money order

- fill in all parts of the cheque or money order and make it payable to the Department of Internal Affairs
- if your cheque is dishonoured you will have to pay additional bank or debt collection charges.

If you pay by credit card or debit card (UK only)

- provide all requested details in section 14 of the form
- note that Diners card is not accepted.

Delivery details

If your delivery address for your new passport is in the same country where you are lodging your application, it will be sent by secure delivery service at no additional cost to you. The delivery service is Courier Post in New Zealand, Express Post in Australia or First Class Mail in the United Kingdom.

If you want your new passport sent to an address outside the country where you are lodging your application, you will need to pay a fee for delivery by international courier. The international courier fee is available in the fees information at www.passports.govt.nz or phone one of the numbers above.

15 Send your application to us

Send us your application or take it to one of the Passport Offices listed below.

We recommend you send your application to us by courier so you can track delivery.

NEW ZEALAND

Courier or post to:
New Zealand Passport Office
Department of Internal Affairs
PO Box 1568
109 Featherston Street
Wellington 6140
New Zealand

Office Locations:

Wellington

New Zealand Passport Office
Department of Internal Affairs
109 Featherston Street
Wellington

*Hours: Monday to Friday 8:30am - 5:00pm,
except Wednesday 9:00am - 5:00pm*

Auckland

New Zealand Passport Office
Department of Internal Affairs
AA Building
99 Albert Street
Auckland

*Hours: Monday to Friday 8:30am - 5:00pm,
except Wednesday 9:00am - 5:00pm*

Manukau

New Zealand Passport Office
Department of Internal Affairs
20-24 Lambie Drive
Manukau City

*Hours: Monday to Friday 8:30am - 5:00pm,
except Wednesday 9:00am - 5:00pm*

Christchurch

New Zealand Passport Office
Department of Internal Affairs
NZI House
96 Hereford Street
Christchurch

*Hours: Monday to Friday 8:30am - 5:00pm,
except Wednesday 9:00am - 5:00pm*

AUSTRALIA

Post to:
New Zealand Passport Office
Department of Internal Affairs
GPO Box 365
Sydney
New South Wales 2001
Australia

Courier or hand deliver in **Sydney** to:

New Zealand Passport Office
Department of Internal Affairs
55 Hunter Street
Sydney

*Hours: Monday to Friday 9:00am - 4:00pm,
except Wednesday 9:30am - 4:00pm*

UNITED KINGDOM

Post, courier, or hand deliver to:

New Zealand Passport Office
Department of Internal Affairs
New Zealand House
80 Haymarket
London SW1Y 4TQ
United Kingdom

Hours: Monday to Friday 10:00am - 2:00pm

OTHER COUNTRIES

If you live outside New Zealand, Australia, or the United Kingdom, either post or courier your application to the New Zealand Passport Office nearest you or contact your nearest New Zealand High Commission or Embassy.

To find the contact details of your nearest New Zealand High Commission or Embassy visit www.mfat.govt.nz

Privacy statement

The information you provide helps us establish your identity and determine if you are eligible for a New Zealand passport. We may obtain information from other sources (including, but not limited to, the Citizenship Office and the Registrar-General of Births, Deaths and Marriages) using an authorised information-matching programme (under Section 78A of the Births, Deaths, Marriages and Relationships Registration Act 1995 or Section 26A of the Citizenship Act 1977).

How is your privacy protected?

All relevant information about you is collected in line with the Passports Act 1992 and is held securely by the New Zealand Passport Office, Department of Internal Affairs, 120 Victoria Street (PO Box 10-526), Wellington.

Under the Privacy Act 1993 you may access and request a correction of any of that personal information.

When may information from your passport records be disclosed?

Under the Passports Act 1992 and the Privacy Act 1993, this information may be disclosed, subject to agreement in writing, to any appropriate agency, body, or person to aid border security, facilitate the processing of passengers, verify the identity of a holder of a travel document, or determine whether a person is a New Zealand citizen.

For more information visit www.dia.govt.nz

The information that may be disclosed includes the information recorded in your passport; your eye colour; your height; the status of your passport; our passport database key number; and any other information relating to your passport that may be required.

Checklist

- Have you re-checked your application form and ensured it has been correctly completed?
- Have you included the correct payment for your application?
- Have you signed the declarations in sections **8** and **9** if applicable?
- Have you signed the applicant declaration in section **11** of your application form?
- Have you supplied 2 identical recent colour photos of yourself?
- Has your witness completed section **13** and signed the back of one photo?
- Have you supplied all required documents  where asked?

Will you need to send any documents with this application?

Please check the following table to see whether you need to send any original documents with your application form. DO NOT send photocopies or certified photocopies. All original documents will be returned to you with your passport.

2 Your entitlement to a New Zealand Passport

Born in New Zealand	-	<i>No document required</i>
Born in Niue, the Cook Islands or Tokelau	<input type="checkbox"/>	Your original Birth Certificate (showing place of birth and parents' names)
New Zealand citizenship by grant or descent	-	<i>No document required</i>
Entitlement for another reason	<input type="checkbox"/>	Any documentary evidence that supports your claim

5 Your previous New Zealand Passport or other New Zealand travel document

If you hold a New Zealand Passport	-	<i>No document required</i>
If you hold a New Zealand Refugee Travel Document, Certificate of Identity or Emergency Travel Document	<input type="checkbox"/>	Your New Zealand Refugee Travel Document, Certificate of Identity or Emergency Travel Document

6 Name change by marriage or civil union

Marriage or civil union registered in New Zealand	-	<i>No document required</i>
Marriage or civil union registered overseas	<input type="checkbox"/>	Your overseas Marriage Certificate or overseas Civil Union Certificate

7 Name change by statutory declaration or deed poll

Born in New Zealand and name changed in New Zealand	-	<i>No document required</i>
Name changed overseas	<input type="checkbox"/>	Your original name change document
Born overseas, name changed in New Zealand after 25/01/2009	-	<i>No document required</i>
Born overseas, name changed in New Zealand before 26/01/2009	<input type="checkbox"/>	Your New Zealand Statutory Name Change Declaration or Deed Poll

9 Declaration for a lost or stolen passport or other travel document

Lost or stolen in New Zealand	<input type="checkbox"/>	A New Zealand police report
Lost or stolen outside New Zealand	<input type="checkbox"/>	A local police report if available

Please note that in some circumstances where the table shows 'No document required' we may need to contact you for further information or original documents if we are unable to verify your details by computer.



Application for a New Zealand Passport

Uruwhenua Aotearoa

Adult



Please use a black or blue ballpoint pen and write in CAPITAL letters in the centre of each box so that our computer software can accurately capture your information.

1 Your personal details

Write your name as you want it to appear in your passport

Surname or family name

First and middle names

Write your place of birth

City or town you were born in

Country you were born in

Write your date of birth

/ / ▶ e.g. / /

Tick your gender

Male

Female

Write your height

(centimetres)

Write your eye colour

▶ e.g. BROWN, BLUE, GREEN, GREY, HAZEL, BLACK

2 Your entitlement to a New Zealand Passport

Tick **only one** of the boxes below

I was born in New Zealand

I was born in Niue, the Cook Islands or Tokelau



*If you were born in Niue, the Cook Islands or Tokelau, you will need to **send your original birth certificate** with this application if you are applying for a New Zealand Passport for the first time, or if your name has changed since your previous passport was issued, or if your previous passport has been lost or stolen.*

I have obtained New Zealand citizenship by grant or descent

Write your Citizenship Certificate number ▶

Write all your names exactly as they are on your Citizenship Certificate

Surname or family name

First and middle names

I am claiming entitlement for another reason



Send us evidence to support your claim.

3 Names at birth

Write your name at your birth

(If you have been legally adopted, write the names you were given **after** adoption.)

Surname or family name

First and middle names

Write your mother's name at **your** birth

Surname or family name

First and middle names

Write your mother's name at **her** birth (maiden name)

Surname or family name

Write your father's name at **your** birth

Surname or family name

First and middle names

4 Your contact and delivery details

Write your home address

Unit and/or house number Street name

Suburb

City or town

Post code

State

Country

Write your contact details

Home phone +

COUNTRY CODE

AREA CODE

PHONE NUMBER

Work phone +

COUNTRY CODE

AREA CODE

PHONE NUMBER

Mobile phone +

COUNTRY CODE

AREA CODE

PHONE NUMBER

Fax +

COUNTRY CODE

AREA CODE

PHONE NUMBER

Please write your email address in CAPITAL letters so that our computer software can accurately capture your information.

Email

@ INTERNETPROVIDER

Write the address you want your passport **delivered** to, if it is not the same as your home address



If you want your passport delivered by **international** courier, you must provide a street address, **not** a Post Box number.

Business name (if required)

Unit and/or house number

Post Box number

Post Box holder name

OR

Street name

Suburb

City or town

Post code

State

Country

5 Your previous New Zealand Passport or other New Zealand travel document



Fill in this section if you have ever had one of the following documents issued by the New Zealand Department of Internal Affairs.

Tick the box below that applies to your **most recent** document

New Zealand Passport

New Zealand Refugee Travel Document

New Zealand Certificate of Identity

New Zealand Emergency Travel Document

Write in the number and your names exactly as they appear in your **most recent** New Zealand Passport or other New Zealand travel document

Document number

Surname or family name

First and middle names



Send us your most recent New Zealand Refugee Travel Document, New Zealand Certificate of Identity or New Zealand Emergency Travel Document with this application. If your document has been lost or stolen fill in section **9**.



If your most recent document is a New Zealand Passport, you do not need to send it to us.



WARNING Once your application has been received your old passport will be cancelled immediately and cannot be used for travel. Anyone attempting to travel on a cancelled passport will be refused travel.

6 Name change by marriage or civil union



Fill in this section if the name you entered in section 1 as the name you want to appear in your passport is a name that was acquired by marriage or civil union. **Otherwise leave this page blank.**

We need details of **ALL** your marriages or civil unions.

Details of your **most recent** marriage or civil union

Tick one box

Marriage

Civil union

Write the details of this marriage or civil union

Surname or family name **before** this marriage or civil union

Date of marriage or civil union

City or town

Country

Your spouse's or partner's surname

Your spouse's or partner's first names

Details of your **second most recent** marriage or civil union

Tick one box

Marriage

Civil union

Write the details of this marriage or civil union

Surname or family name **before** this marriage or civil union

Date of marriage or civil union

City or town

Country

Your spouse's or partner's surname

Your spouse's or partner's first names



Send us the original marriage or civil union certificate for each marriage or civil union **registered outside New Zealand.**



If you have had **more than two marriages or civil unions**, write the details (using the same format) on a separate piece of paper and send it with this application form.

9 Declaration for a lost or stolen passport or other travel document



Fill in this page only if you are renewing your New Zealand Passport and it has been lost or stolen, or if you are applying for a New Zealand Passport for the first time and your other New Zealand travel document has been lost or stolen. **Otherwise leave this page blank.**

Tick one box to show which document has been lost or stolen

Passport

Refugee Travel Document

Certificate of Identity

Tick what happened to the document

Lost

Stolen

Date lost or stolen? ▶

DD / MM / YYYY

Explain how the document was lost or stolen

Write in as many details as possible. Include the address where the loss or theft occurred

[Empty text box for explanation]



Send us a separate piece of paper with further details if you have run out of space to write on this page.

Write the passport or travel document number, and the place and date of issue, if you know these

Number

Place it was issued

[Number and Place input fields]

Date it was issued

DD / MM / YYYY

Write your name and date of birth as they appeared in the passport or travel document

Surname or family name

[Surname input field]

First and middle names

[First and middle names input field]

Date of birth

DD / MM / YYYY



If your passport or travel document has been lost or stolen in New Zealand, you must report the loss or theft of your passport or travel document to the Police and the Department of Internal Affairs and you must send us a police report.

If your passport or travel document has been lost or stolen overseas, contact the nearest NZ Passport Office or NZ Embassy, High Commission or Consulate, report the loss or theft to local police, and provide a local police report or reference number.

Police reference number

Tick to confirm ▶

I have reported it to the Department of Internal Affairs

I have enclosed a police report

[Police reference number input field]

Declaration

- ▶ I declare that the information above is correct and undertake that if the lost or stolen passport or travel document is found or returned to me, I will return it immediately for cancellation to the Passport Office or to a New Zealand Embassy, High Commission or Consulate.
- ▶ I acknowledge that in notifying the loss or theft of my passport or travel document to the Passport Office or to a New Zealand Embassy, High Commission or Consulate, that it will be permanently cancelled and rendered unusable.



WARNING Once you declare your passport lost or stolen, it cannot be used for travel. It will be cancelled immediately and Interpol and border authorities will be advised. Anyone attempting to travel on a passport that has been lost or stolen will be refused travel. It is an offence against the Passports Act 1992 to knowingly or recklessly make a false statement to obtain another passport. To do so may result in a fine, imprisonment, or both.

Sign your Declaration here



DECLARANT SIGN HERE

Date signed

DD / MM / YYYY

10 Your emergency contact

Write the name and contact details of a person who can be contacted in case of emergency

Surname or family name

First and middle names

Write their address and contact details

Unit and/or house number

Street name

Suburb

City or town

Post code

State

Country

Home phone +

Daytime phone +

COUNTRY CODE

AREA CODE

PHONE NUMBER

COUNTRY CODE

AREA CODE

PHONE NUMBER

Email

USERNAME

@ INTERNETPROVIDER

11 Your Applicant Declaration

Tick one box

I have completed this application in my own handwriting.

Someone else has filled in this application for me because I have a disability or language difficulty.



If someone else has filled in this application for you but you are able to sign your own name, you must sign this section. If you are unable to sign your own name, the signature in this section must be left blank. The person who filled in the application form for you must not sign this section but must sign the statutory declaration in section 8.

- ▶ I declare that the information I have given in this application is, to the best of my knowledge, true, complete and correct.
- ▶ I understand that if I have provided false information my passport can be cancelled and I can, by law, be fined or imprisoned.
- ▶ I confirm that I have read the section relating to Privacy in the Guide Notes for this application.
- ▶ I agree that, for the purposes of this application, other government agencies may release personal information about myself which will assist the Passport Office in determining my entitlement to be issued with, or continue to hold, a New Zealand Passport.
- ▶ I understand that if I use, or have possession of, a forged or false New Zealand travel document, I may be liable on conviction to imprisonment for a term not exceeding 10 years, a fine not exceeding NZ\$250,000.00, or both.



WARNING It is an offence against the Passports Act 1992 to knowingly or recklessly make a statement that is false or misleading in a material particular for the purposes of gaining a New Zealand Passport.

Sign your Applicant Declaration here



APPLICANT SIGN HERE

Date signed

D D / M M / Y Y Y Y

12 Your name for your witness to confirm

Write your name again, as you wrote it in section **1**, so that your witness can confirm your identity

Surname or family name

First and middle names

13 Witness section



Before completing this section your witness must read section **13** of the Guide Notes. Your witness must fill in this section in their own handwriting and complete the details on the back of one photo.

Tick both these boxes to make sure you can be a witness

I am the holder of a valid New Zealand Passport

The applicant is not related to me, is not my spouse or partner and does not live at the same address as me

Write your New Zealand Passport number ▶

Write how many years you have known the applicant ▶

 years

Write your name

Surname or family name

First and middle names

Write your address and contact details

Write your date of birth ▶

Unit and/or house number

Street name

City or town

Post code

State

Country

Home phone +

COUNTRY CODE AREA CODE

PHONE NUMBER

Daytime phone +

COUNTRY CODE AREA CODE

PHONE NUMBER

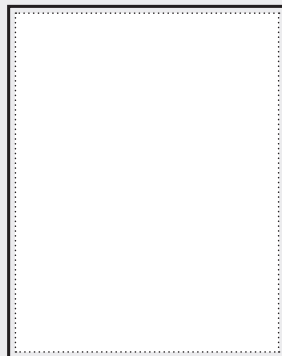

I declare that

- ▶ I am 16 years of age or over
- ▶ I have known the applicant for more than 1 year
- ▶ The information I have given is in my own handwriting and complete and correct to the best of my knowledge
- ▶ The person in this photo is the person named in section **12**
- ▶ I have written the full name of the applicant, signed my name and written the date on the back of one photograph
- ▶ I understand that if I have provided false information, this passport can be cancelled and I can, by law, be fined or imprisoned.



WARNING It is an offence against the Passports Act 1992 to knowingly or recklessly make a false statement to help anyone get a passport.

Signature
of witness



WITNESS SIGN HERE

Date signed

FEES SHEET

Application for a New Zealand Passport

All fees must be paid in the currency of the country where you are sending your application form to be processed.

Application Fees

If you are lodging your application:

- in New Zealand, make your payment in New Zealand dollars
- at the New Zealand Passport Office in Sydney, make your payment in Australian dollars
- at the New Zealand Passport Office in London, make your payment in Great British pounds.

ADULT / ADULT RENEWAL	Lodged in New Zealand	Lodged in Australia	Lodged in the United Kingdom
Total cost of each application for Standard Service (up to 10 working days)	NZD \$153.30	AUD \$162.00	GBP £76.00
Total cost of each application for Urgent Service (up to 3 working days)	NZD \$306.60	AUD \$324.00	GBP £152.00
Total cost of each application for Callout Service (by appointment only)	NZD \$664.30	AUD \$622.00	GBP £291.00

CHILD	Lodged in New Zealand	Lodged in Australia	Lodged in the United Kingdom
Total cost of each application for Standard Service (up to 10 working days)	NZD \$81.70	AUD \$83.00	GBP £40.00
Total cost of each application for Urgent Service (up to 3 working days)	NZD \$235.00	AUD \$245.00	GBP £116.00
Total cost of each application for Callout Service (by appointment only)	NZD \$592.70	AUD \$543.00	GBP £255.00

International Courier Fees

If you want your passport delivered to a country different from the country where you are lodging your application, you will need to pay an international courier fee for delivery.

DELIVERY ZONE	Lodged in New Zealand	Lodged in Australia	Lodged in the United Kingdom
New Zealand	Included in application fee	Lodge your application in New Zealand	Lodge your application in New Zealand
Australia	NZD \$10.00	Included in application fee	Lodge your application in Australia
United Kingdom	NZD \$25.00	Lodge your application in the United Kingdom	UK First Class Mail – included in application fee Courier – GBP £9.00
Asia Pacific countries	NZD \$15.00	AUD \$24.00	Lodge your application in New Zealand or Australia
United States	NZD \$20.00	AUD \$28.00	GBP £22.50
Europe (excluding the UK)	NZD \$25.00	Lodge your application in the United Kingdom	GBP £13.50
the 'Rest of World'	NZD \$25.00	Lodge your application in New Zealand or the United Kingdom	GBP £29.50

NOTE:

- If your delivery address is in Pakistan or the Ukraine – please lodge your application in the United Kingdom.
- If your delivery address is in Iran – please contact the New Zealand Embassy in Tehran for further advice.

Please note that international deliveries may be subject to additional fees and charges, imposed for example by the courier company and/or customs of the country where your new passport is being delivered to.

These fees and charges can not be paid in advance to the Department, instead have to be paid directly by the applicant in the country of delivery.