

Compact Evaporator

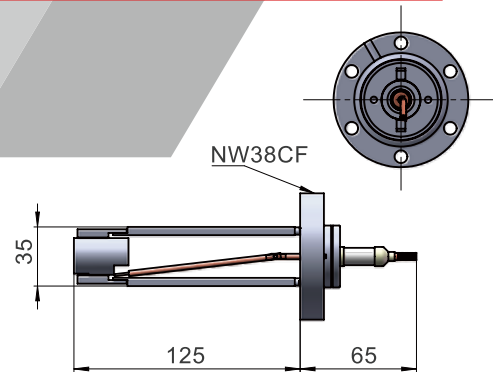

Part Number CE38



For some occasions, a quick and afford evaporation method would be required, for example making gold/ silver contact on thin films or some reference gold layer. Effusion cells will then be a too luxury and complex option as flux precision and stability will not be taken into consideration.

Compact evaporators are then offered as an easier way for material deposition.

High Light

- ✔ Less mechanically complex and could be ramped up/ down in a much faster way
- ✔ Smaller dimensions and easier to install
- ✔ Easier to fill and service
- ✔ Larger orifice diameters to increase material flux, suitable for contact preparation
- ✔ Higher deposition rates

— Au Flux Test —

