

The Shade Rises Unevenly, Does Not Return, or is Noisy?

- 1) Lift cords are not uniformly taut (check when shade is fully lowered, all lift lines should have equal tension on them). Lift cords should never be slack in any position.
- 2) Cord clips need to be uniformly spaced on the shaft from the brackets (ie; don't have one clip $\frac{1}{2}$ inch away from the bracket and another 2 inches away.)
- 3) Tails of knots in the cord clips must be facing away from the clutch when properly installed.
- 4) When in the fully lowered position there shouldn't be any cord wrapped on the shaft at all ..."Edge lift" cord knots will be on top of the shaft, "Internal Lift" cord knots will be on the bottom of the shaft. (see Figure B)

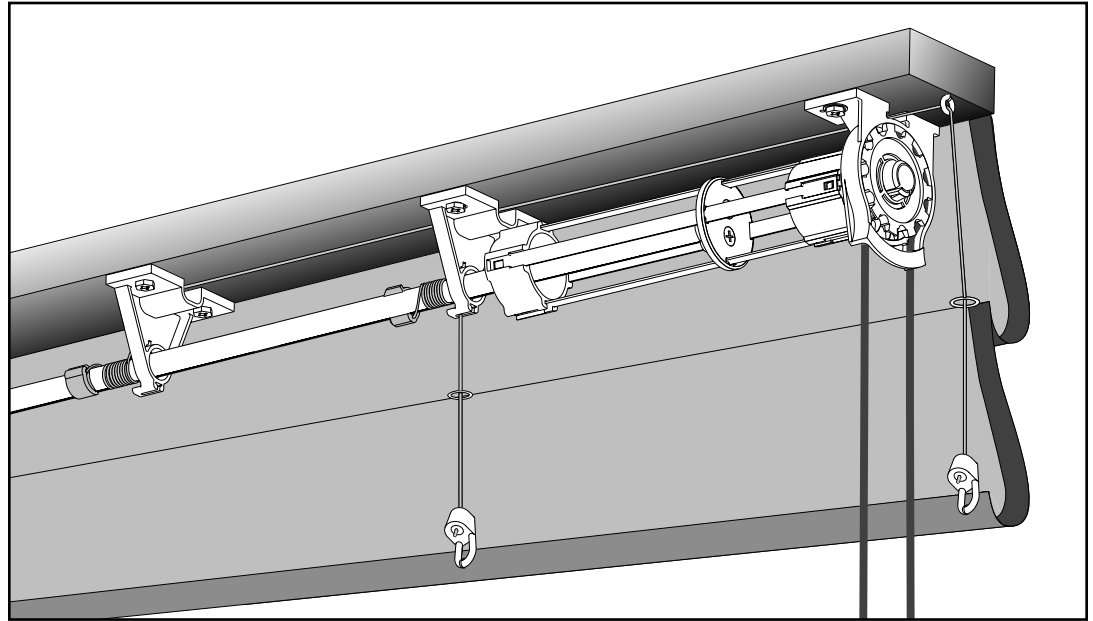

- 5) Not sufficient weight in the bottom of the shade.
- 6) Lift cords may wrap around cord clips because there's not enough room between lift lines. (need to allow 1 inch of shaft space for every 3 feet of drop)
- 7) Shade catching in window...check to make sure window hardware or crank is not an obstruction.
- 8) Shaft Bent?
- 9) Drive disk not square on the shaft. Was the shaft cut square? Was the shaft deburred when cut?
- 10) All Spears must be securely locked into the clutch and spear retainer.
- 11) Mounting board bowed or warped?
- 12) Brackets have been screwed too tightly or unevenly to board causing them to be out of alignment.
- 13) "L" mounting bracket is not close enough to the clutch? When control cord is pulled, board may be temporarily twisted enough to put shaft out of alignment with brackets. "L" brackets mounted close to clutch help prevent any board twisting.

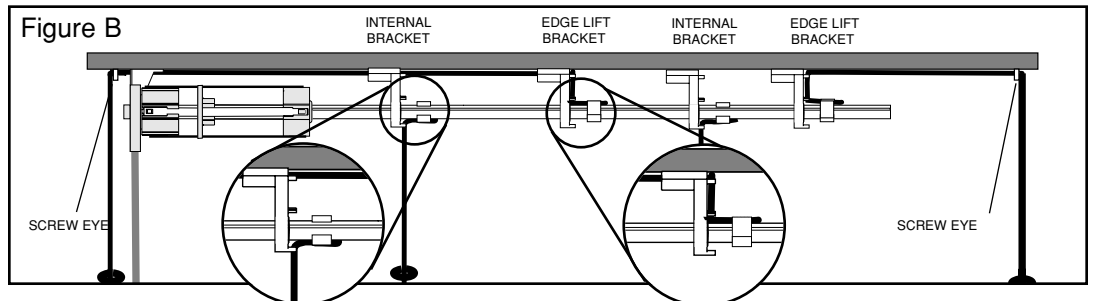

Control Cord Slipping in Clutch?

- 1) Shade too heavy? Standard clutch: 30 lbs maximum, Slim Clutch: 15 lbs maximum, Shades over 10 lbs **must** use metal bead chain.