

Establishing Talk Groups Using NCS-C250s in a Parallel Configuration

Introduction

A Talk Group for the purpose of this discussion is defined as two or more groups or agencies operating on different frequencies that are linked together allowing all parties to communicate with each other.

Multiple agency incident response often requires the use of multiple talk groups to reduce confusion and expedite communications between parties requiring common communications. Often times many of the responding agencies' communications systems are operating on different frequencies and thus cannot communicate with each other without the use of equipment that interconnects these systems. This is often accomplished by using a cross-band repeater to link responders operating on different frequencies. The NCS-C250 is designed to meet this requirement and in the cross-band repeat mode can link up to 4 different radios allowing responders operating on different frequencies to communicate.

However, linking up to four different frequencies or agencies in some situations can lead to confusion and less efficient communications. By using multiple talk groups and assigning only agencies that need to communicate with each other to the same talk group, communications efficiency is greatly improved.

Parallel Operation of the NCS-C250 and NCS-C251

Parallel operation of the NCS-C250 allows multiple operating positions to access a common suite of four radios. The NCS-C250 parallel configuration is illustrated in Figure 1. This configuration is often used to accommodate multiple operating positions sharing access to the same radios. See Application Note NCS-AN-101 for a more detailed discussion of parallel operation. While the NCS-C250 is not designed to support multiple talk groups, this can be accomplished with two (or more) NCS-C250s connected in a parallel configuration.

Establishing Talk Groups

When multiple NCS-C250s are connected in a parallel configuration, each unit functions independently. A single talk group or net can be established on each NCS-C250 by placing the unit in the *Repeat Mode* and selecting the desired radios for cross-banding. For example, as shown in Figure 2, the first NCS-C250 could be setup to establish Talk Group 1 by selecting radios 1 & 2 and the second NCS-C250 could be setup to establish Talk Group 2 by selecting radios 3 & 4. By using the NCS-C251 Expansion Unit in conjunction with the NCS-C250, additional radios can be added to each talk group. An example is shown in Figure 3.

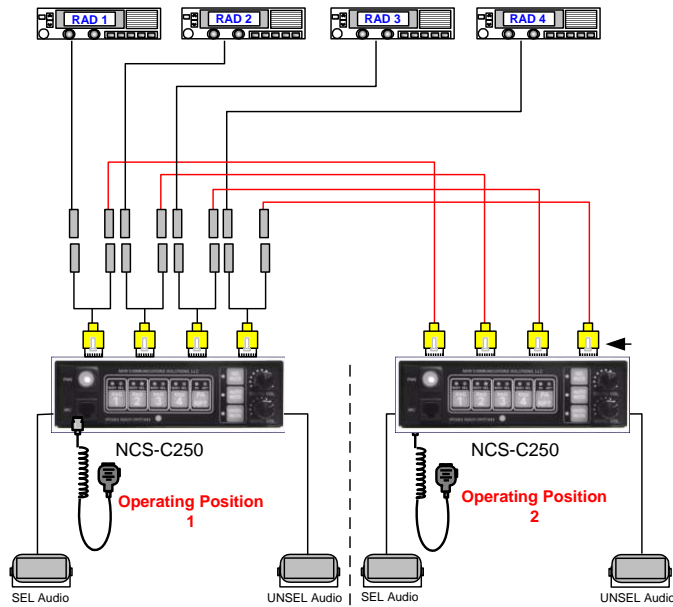

Figure 1 - Typical NCS-C250 Parallel Configuration

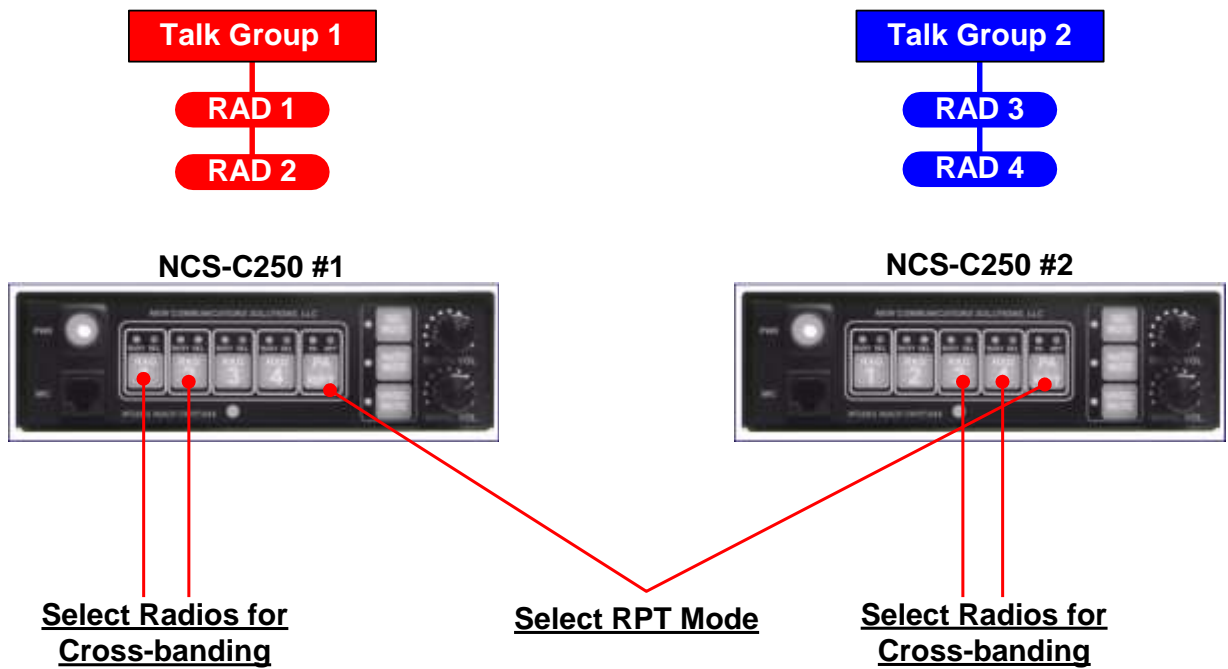

Figure 2 - Example of Establishing Talk Groups

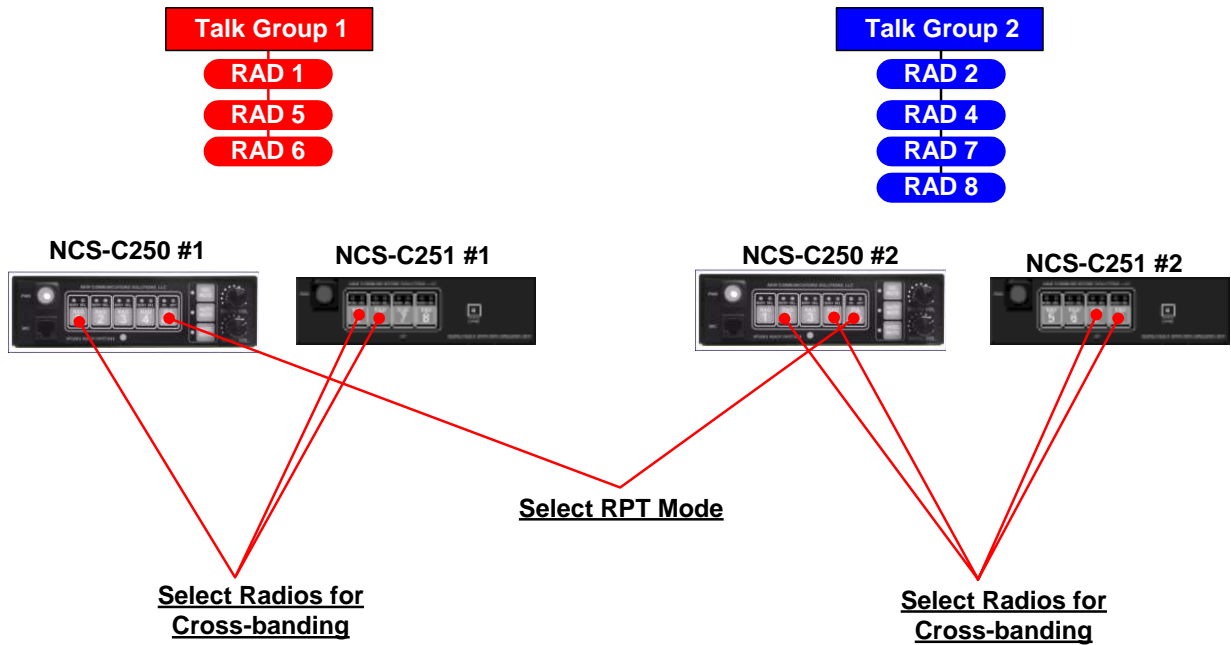

Figure 3 – Adding Additional Radios to Talk Groups Using the NCS-C251

Typical Application

Figure 4 shows a typical application using Talk Groups by utilizing two NCS-C250s in a parallel configuration. In this hypothetical situation local fire communications is via an 800 MHz trunked system that is linked to mutual aid fire communications operating on a VHF simplex frequency. This is Talk Group 1. Talk Group 2 consists of Local police communications via a UHF repeater system that is linked to mutual aid EMS operating on an iDEN cellular network.

The dispatchers, as required to meet the demands of the situation, can reconfigure each Talk Group. Reconfiguring the Talk Groups is simple and can be accomplished quickly.

The dispatcher at Operating Position 1 can communicate via the local mic, connected to the NCS-C250, with all stations on Talk Group 1 and likewise, the dispatcher at Operating Position 2 can communicate with all stations on Talk Group 2.

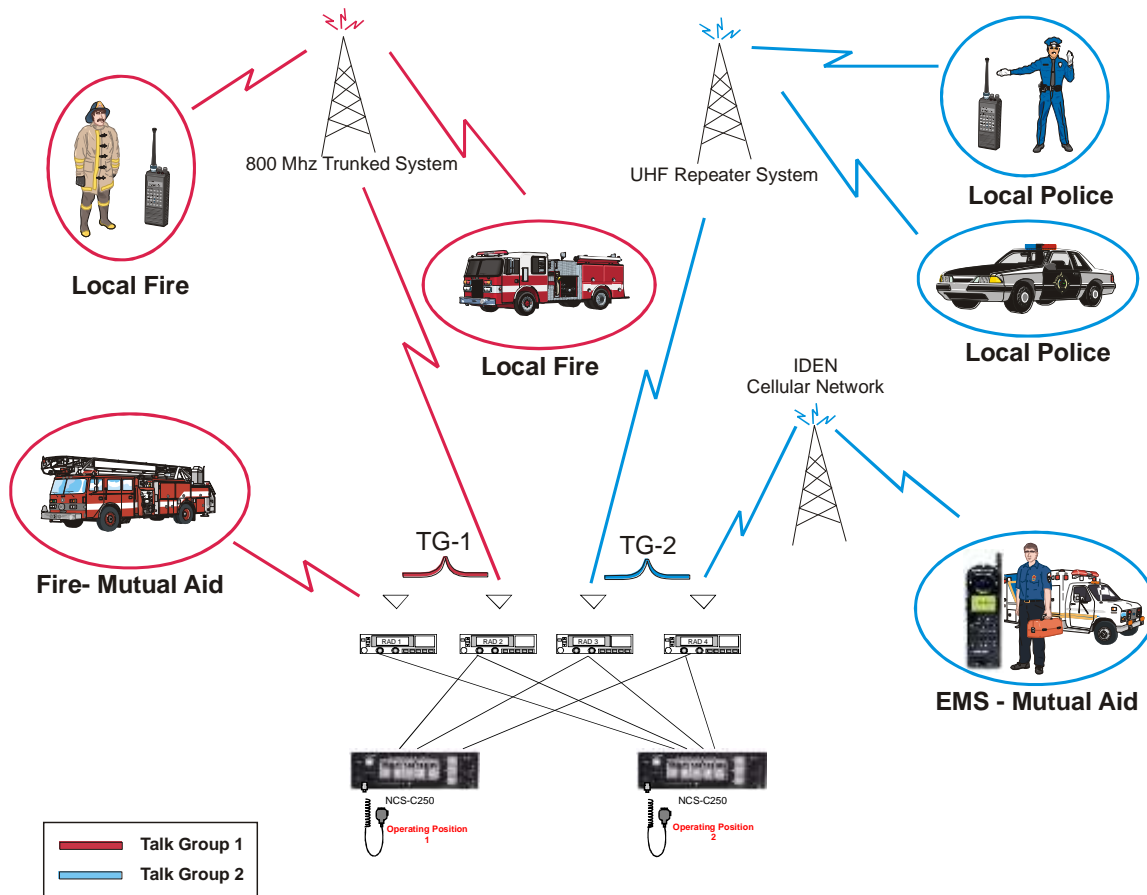

Figure 4 - Typical Application

Contact Us

If you have questions or need assistance with your application, please contact us.

Tel/Fax: 888-883-5788
 Email: support@ncsradio.com