

# **First**<sup>®</sup> **Fuel Injection** SYSTEMS



# Before You Begin

This manual should be carefully studied and understood **before** you remove your carburetor. Some installations require additional parts and special tools are needed. Also, you must be qualified on, or have access to, specialized testing equipment.

It is important to be thoroughly familiar with all of the warnings and precautions we have provided you. Failure to do so could void your warranty.

**This system must be installed by competent personnel** with good understanding of modifications that may be needed to your fuel system, such as return line added to your tank and installation of high pressure fuel pump, which may require installing new lines. Care and caution must be exercised while working with fuel system modifications.

**Avoid open sparks, flames, and the operation of electrical devices.**

**Always perform wiring modifications with battery cables disconnected.**

You may have to remove the fuel tank to install a fuel return line or remove an existing pump or restriction. Read this section carefully.

For safe and proper fuel tank removal instructions, please refer to The vehicle's specific repair manual (Chilton's, Motors, etc.)

**Never use the vapor return line from the charcoal canister as a fuel return line.**

Intake port matching can be done for maximum performance, but care should be taken when enlarging the manifold ports so that gasket surfaces are adequate and the structural stability remains intact.

The intake manifold flange was purposely designed to be compatible with aluminum "Raised Port" heads. Because of this, it may be necessary to file the manifold base, trim the valve cover or use extra thick valve cover gaskets. Check this fit before final assembly.

## Pre-installation checklist

Open all packages and carefully check the contents. Be sure you have all of the system components and hardware. **Fuel line and fittings are not included in kit!**

All fuel system components must be mounted as far as possible from heat sources, and must be well vented.

**NO LEAKS CAN BE ALLOWED IN THE FUEL SYSTEM. CHECK FOR LEAKS AT THE RAILS AND INJECTORS BEFORE INSTALLING THE RUNNERS AND PLENUM.**

If it is not obvious which throttle body configuration will be right for your application, the dimensions shown in Figure 1, page 7 may be helpful. The overall height of the manifold is the same as the 1985-88 Corvette or IROC Camaro.

**If the pump is not mounted inside the fuel tank**, there are a few considerations that you must remember: The fuel pump must be as close to the tank as possible and lower than the fuel level if at all possible. This will ensure maximum output and the least amount of fuel delivery problems.

The fuel filter should be mounted between the tank and pump as close as possible to the fuel pump, but lower than the fuel tank if at all possible and it is recommended to install a second filter after the pump.

In extremely hot climates the use of reflective shields protects the fuel system against heat absorption.

Use the coolest surfaces of vehicle chassis as heat sink for components. Using thermally conductive brackets enhances the heat transfer.

**Avoid sharp bends**, reducing fittings, or crimps in fuel lines.

Use only non-perforated clamps. Be sure the hose extends beyond the clamps at least ½ the clamp width.

**DO NOT CUT braided fuel lines.** It takes a special saw or the fitting may leak.

Do not use methanol or ethanol fuel products.

Do not substitute any component of this system regardless of specifications.

Make sure the fuel tank is clean and free of rust or solid particles. It must be properly coated i.e. galvanized. Plastic fuel tanks are acceptable. 3

## System description

**The FIRST®** fuel injection system is a bolt-on high performance, electronically controlled Tuned Port System. It utilizes an 8 point port injected manifold with tuned runners and air plenum. It has no equal in the world of fuel injection.

The system is currently only offered for GM (Chevrolet) small Blocks.

## System Diagram

The components of the **FIRST®** System will be examined in various illustrations to familiarize yourself with the system components, read through the entire installation procedure.

The movement to decrease exhaust emissions has led to very complex fuel systems. **The FIRST®** TPI System replaces the standard carburetor, and intake manifold, an integral part of the fuel system.

Installation of the **FIRST®** TPI system may require some modification of the fuel system.

Be sure you understand which modifications and additional parts are needed for your vehicle.

## Typical Sensors

MAT- Manifold Air Temp



TPS- Throttle Position Sensor



MAP- Manifold Air Pressure



O2- Oxygen Sensor



CTS- Coolant Temp Sensor



IAC- Idle Air Control



# Typical Sensor Location

MAP- Manifold air pressure sensor. Usually located in the right rear of the plenum. If you are not using the optional bracket, you must try and make sure to keep the sensor within 8 inches of the vac. Source. **Standard part number AS5T**

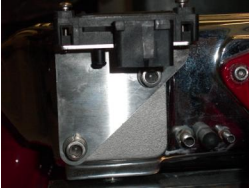

MAT-Manifold air temp. Located on the bottom of the plenum. **Standard part number AX1T**



O2-Sensor located on your exhaust system.



CTS-Coolant Air Temp is located in one of the 3/8" water pipe passages. **Standard Part Number TX3T**



TPS- Throttle position sensor is located on the right side of the throttle body and will need to be set to .5v - .65v between pins b and c with a digital volt meter at closed throttle during final set up. **Standard Part # TH37T**

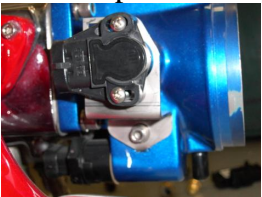

IAC-Idle Air Control is located on the bottom of the throttle body. **Standard Part Number AC1T**

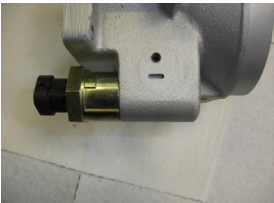

# Installation

## Cleanliness guidelines

Do not use fluffy or dusty cloths.

Thoroughly clean all unions and areas near connections before disconnecting fuel lines.

Place removed parts on a clean surface and cover. Use paper or plastic sheets.

Components which have been opened or disassembled must be covered or sealed carefully if repair cannot be carried out immediately.

Install clean components only. Unpack parts just prior to installation.

DO NOT use parts that have been stored loose. ( i.e. toolboxes, etc.)

When the fuel system is open:

Do not move vehicle unless absolutely necessary.

Be sure to clean out all open fuel lines to remove any dirt or debris that may have entered the lines while they were open or installed.

### Basic manifold dimensions

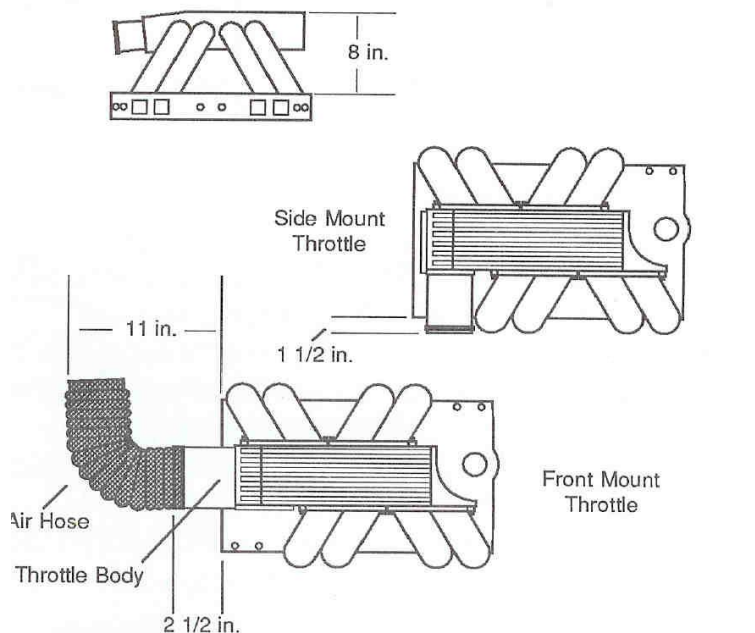

Figure 1

## **Required equipment**

Along with the usual shop equipment, there are a few items that will make the installation and adjustments of the Fuel Injection system easier.

Fuel pressure gauge (0 -100 psi) with ¼” male pipe fitting

Volt-ohm meter

Test light, 12 volt

Hole punch or hole saw 1-1/8”

Tubing cutter up to ½”

Drill bits, 1/4” & 1/8”

American standard and metric wrenches, ratchets, sockets, screwdrivers

Razor or cutting knife (never cut fuel line with dyke cutters). Use only razor edge hose cutter or a razor blade.

Scrape tool

3/16 ball driver for allen head cap screws

¼ Hex Driver

## **Special Testing Equipment**

Engine analyzer

Exhaust gas analyzer (2 gas or 4 gas)

## Preparation for Installation

1. Start the engine and run it until warm. Identify all vacuum lines to air cleaner. Remove the air cleaner from the carburetor, plug all open vacuum lines.
2. Remove the vacuum lines from the carburetor one at a time and determine what type of vacuum signals are present: manifold, ported and late ported. Using a vacuum gauge, determine these three sources and label them accordingly.
  - a) Manifold vacuum is present at idle
  - b) Early ported vacuum is not present at idle, but becomes active as the throttle is opened.
  - c) Late ported vacuum becomes active as the throttle is opened further. ( See Figure 2, next page)

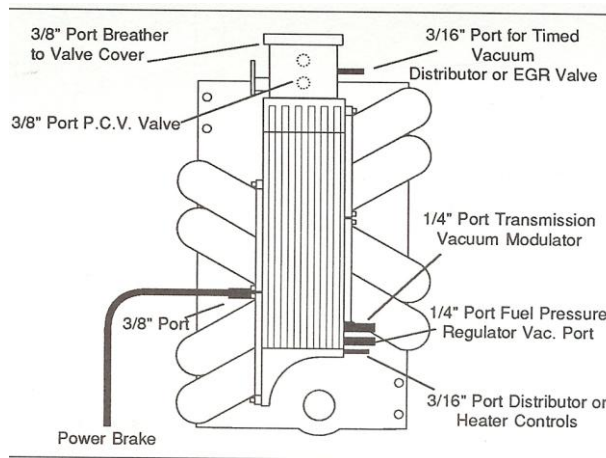

**Figure 2**

3. If a cruise control system exists, make a note of the linkage for reassembly.
4. Write down the location of the spark plug wires in the distributor cap. Remove the cap and “bump” the starter until the rotor is pointing straight back.
5. Disconnect the battery.
6. Note how the rotor runs while **slowly** lifting the distributor straight up. The reverse action of this must take place during replacement.
7. Drain the cooling system.
8. Tag all wires, hoses and lines that must be reconnected after the installation of the TPI manifold.
9. Remove all the accessories and related brackets attached to the intake manifold.
10. Remove the intake manifold and clean all the gasket surfaces thoroughly.



## Installation (Section2)

1. The oil pressure sending unit will probably have to be repositioned, may require 1/8 point N.P.T 45 degree elbow fitting. If this proves unsatisfactory, relocation to the front of the block or the port above the oil filter may be necessary.
2. Using the intake manifold gaskets supplied in the kit, bolt the manifold base to the cylinder heads. (We recommend using gasket sealer on the water passage surfaces. We also recommend the use of oil resistant RTV silicone to substitute troublesome end gaskets.)
3. At this time, install all 8 injectors. Lube the O-rings with some light oil and press them firmly into the intake injector bungs. Any Bosch style injector may be used. **IF YOU ARE SUPPLYING YOUR OWN FUEL INJECTORS, MAKE SURE THAT YOU CHECK THE HEIGHT OF THE INJECTORS, SO THAT THERE ARE NO LEAKS. SOME OF THE AFTERMARKET COMPANIES MAKE THEM SHORTER AND REQUIRE YOU TO MODIFY THE FUEL RAIL MOUNTING PADS ON THE MANIFOLDS.**
4. Install the fuel rails on top of the fuel injectors at this time by firmly pressing each rail down onto the top of the injectors and bolt down the rail with the two 1" 1/4-20 bolts. See figure 9A



Figure 9A

5. It is easier to install your fuel line hose to the fuel rail at this time. Referring to Figure 9, determine a suitable mounting location for the secondary fuel filter and fuel pressure regulator with gauge. Allowing a little extra length, cut the 3/8" supply and 3/8" return line to reach from the fuel rail to their respective locations.

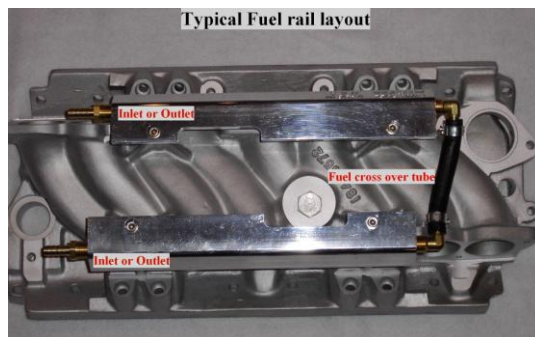

Figure 9

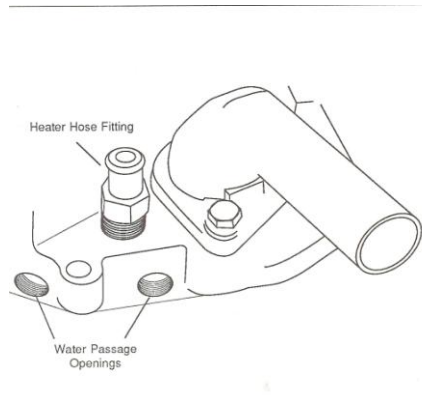

Figure 3

6. Tighten the manifold bolts starting in the center and working outward, alternating from side to side. Special intake manifold base bolts are supplied with unit.
7. On side mount throttle applications, install the heater hose fitting next to the thermostat housing. On front mounted throttles, the heater hose could possibly connect to one of two forward facing water passage openings. (Figure 3)
8. Install O.E.M. sensors or plugs in the remaining openings. (Use of sealer is recommended).
9. A 90° thermostat swivel housing for front mounted throttle applications is recommended.
10. On Non-EGR applications, use this plug (Figure 4)

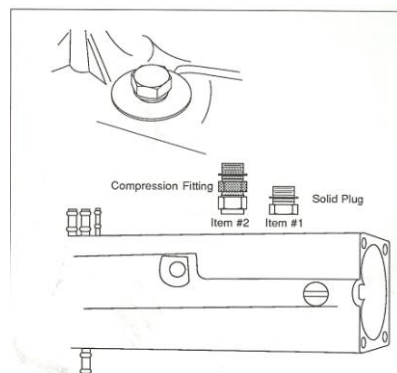

Figure 4

11. Mount a fuel pressure regulator. The smaller vacuum port on the rear of the plenum connects to the fuel regulator. Keep in mind, fuel pressure tests will be made before the regulator. (See figure 9)
12. Connect a (3/8") return fuel line hose from the rear of the fuel rail to the port on the fuel regulator.

13. Connect the “Output” port of the regulator to the line returning to the tank.  
**AT THIS TIME, IT IS VERY IMPORTANT TO CHECK YOUR FUEL SYSTEM FOR LEAKS. MAKE SURE ALL YOUR FUEL SYSTEM CONNECTIONS ARE MADE AND PRESSURIZE THE FUEL RAILS TO CHECK FOR LEAKS. THIS WILL MAKE THINGS A WHOLE LOT EASIER THAN TAKING APART THE ENTIRE MANIFOLD IF YOU EXPERIENCE ANY LEAKS AT THE RAILS.**
14. Locate 4 manifold runners, 8 manifold runner gaskets and (24) ¼-20x1 allen head cap screws.
15. Loosely bolt runners to manifold base making sure **TO APPLY THREAD SEALANT TO LOWER RIGHT FRONT RUNNER BOLT, AS IT ENTERS THE COOLANT PASSAGE.**
16. Slip the wiring harness into the center of the manifold base between the fuel rails. The harness must pass under any fuel cross over hoses. Loosely secure to fuel rails with the wraps. **Keep wiring harness away from EGR cross over fitting (it does get hot).**
17. Route the fuel injector leads over the fuel rail and onto their respective injectors.
- 18. On side mounted throttle applications, rotate the injectors for cylinders 1 and 3 so the electrical connectors face toward the rear.**
19. The main body of the wiring harness will exit to the passenger side in front of the distributor.
20. Install distributor in the reverse order from which it was removed. On large cap H.E.I. distributors you may have to remove some of the casting on the bottom of the distributor to allow sufficient clearance and for timing adjustments. If using the small cap dist. With standard heads you can mount the remote coil on the right rear flat surface of the intake base.

See picture 4B



Picture 4

21. When retaining the E.G.R. system, the large compression fitting must be installed into the bottom of the plenum.  
(Refer to Figure 4 page 10)

22. On Non-E.G.R. applications use the solid plug.

23. Install the (MAT) manifold air temp in the bottom of the plenum in the 3/8" pipe hole at this time. See figure 4a.



Figure 4a

24. Plug in the MAT sensor at this time then loosely bolt the plenum with the plenum/runner gaskets to the runners using the 1/4-20x1" allen head cap screws.

25. On E.G.R. applications ensure the coupling of the two manifold base to the plenum fittings. It is best to tighten this coupler from the front of the plenum (with a 15/16" wrench) after the runners are installed & before the throttlebody is installed. It is a tight & tedious task, so patience is required.

26. Install the "driver Front" runner in the same manner.

27. Tighten the E.G.R. compression fitting nut ( if applicable).

28. Install the "Passenger Rear" runner in the same manner.

29. Install coolant temp sensor (CTS) into one of the 3/8" pipe water passage openings in the forward part of the base manifold. See figure 3A.



Figure 3A

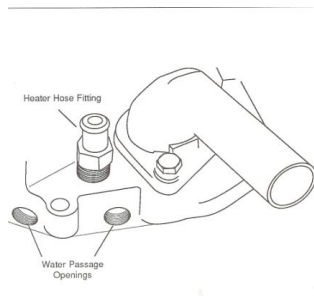

30. Tighten all 24 runner allen head cap screws at this time.

31. Mount the throttle body block off plate with gasket over the side opening on the plenum. Take care to make sure that you use the short 5/16" – 18x3/4" bolts in the front, otherwise they will run into the throttle body bolts. (2) 5/16" - 18x1" allen head cap screws secure the throttle cable bracket. Use one lock washer as a spacer between the bracket and the plate.

32. Install the MAP sensor bracket and the EGR block off plate with gasket to the right rear corner of the plenum. Use 2 5/16"-18x5/8" allen head cap screw heads. Install MAP sensor to bracket with 2 8-32 1" Phillips machine screws. See picture 12.

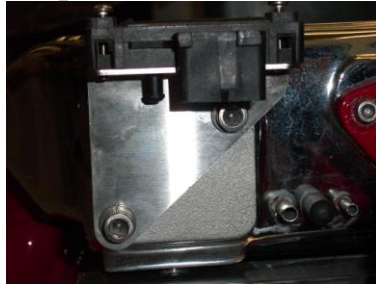

Picture 12

33. If an automatic transmission is used, mount a detent cable linkage stud to the throttle arm upper hole.

34. If modifying an existing throttle cable to work with the FIRST throttle linkage, you must purchase the plastic tear drop end for your cable. This will allow it to clip onto the existing stud on the throttle linkage.

35. Install the (IAC) Idle Air Control valve in the bottom throttle body passage. Plug the 4 pin harness connector into the fast idle valve on the throttle body before mounting the throttle to the plenum.



Picture 12a

**NOTE** (IAC) fast idle valve may need to be set to the idle plate to obtain proper idle correction. See procedure below.

- |                                  |                    |                                |
|----------------------------------|--------------------|--------------------------------|
| 1. Turn ignition on              | 5. Turn off Key    | 9. Turn off ignition           |
| 2. Jump A&B on ALDL              | 6. Unplug Jumper   | 10. Wait 15 seconds            |
| 3. Wait 1 minute until IAC seats | 7. Start up & Idle | 11. Start & idle should be set |
| 4. Unplug IAC                    | 8. Plug in IAC     |                                |

## On Front Mounted Throttle Body Assemblies

1. Secure the throttle body to the plenum with 4 5/16" 18 allen head cap screws arranging gaskets as in figure 6

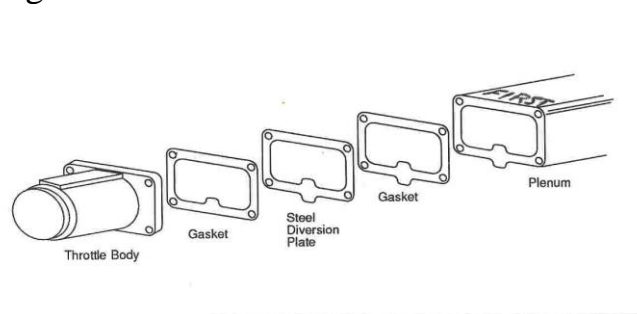
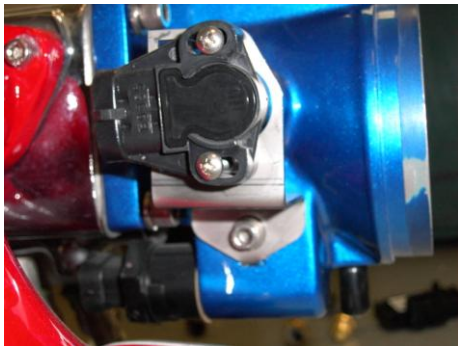
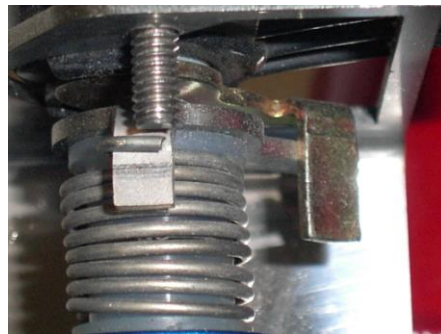

Figure 6

2. Install the (TPS) Throttle position sensor bracket to the right side of the throttle body with (1) 1/2" 1/4-20 bolt. See picture 6A
3. Mount the TPS. Be sure to have TPS lever positioned on top of the throttle arm. See picture 6B.
4. Then connect the harness. This sensor does need to be set to .5v-.65v between pins b and c with a digital volt meter before starting the engine.



Picture 6A



Picture 6B

## On the Side mounted Throttle Body Assemblies

5. Mount the block off plate to the front of the plenum using four 5/16"-18x5/8" allen head cap screws. Take care to make sure you use the short bolts to the throttle body side, otherwise they will run into the throttle body bolts. Use the gaskets and plate shown in figure 6.
6. A 1/8" space is required between the throttle cable bracket and the underneath side of the throttle body. Two 1/4" 20x 1/2" allen head cap screws with lock washers secure the bracket.
7. Install the (TPS) Throttle position sensor bracket to the right side of the throttle body with 1/2" 1/4-20 bolt. See picture 6A.

8. Mount the TPS. Be sure to have TPS lever positioned on top of the throttle arm. See picture 6B. Also do not forget to set voltage as in line 4 above.
9. One 1/4" -20x 3/8" allen head cap screw and lock washer attach the bracket to the throttle body. See Motors or Chilton manual for correct adjustment of this switch.
- 10.If you would like some additional throttle pressure, use the small return spring. The mounting tab is anchored under the upper right throttle body bolt. See picture 7A

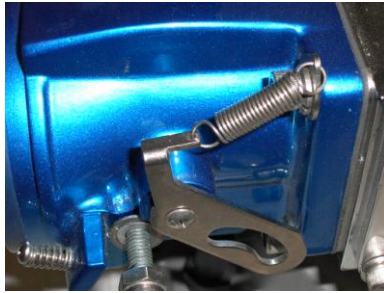

**Picture 7A**

### **Fuel Return Line Installation**

There are two options for accommodating a return line for your vehicle if you do not already have one. The one described in the following instructions or a kit that is offered in Jeg's made by Moroso to be installed in the fuel tank filler tube, part #710-65385, which may be easier for some.

If your fuel system must be altered, at this time, jack the vehicle up far enough to comfortably move about beneath it and support it with jack stands or ramps.

**\*\*\* Never go under a vehicle supported only by a jack.**

**\*\*\* Gasoline vapors are explosive; heavier than air and accumulate close to the floor.**

**\*\*\* Double check that the battery terminals are disconnected.**

**\*\*\* If the fuel tank must be removed, we recommend that you follow the detailed instructions in the repair manual specific to your vehicle.**

**\*\*\* Have a fully charged Type B fire extinguisher handy and always wear eye protection.**

Return tube should be as long as the fuel pickup line to ensure returning fuel enters the tank below the fuel level. This is to reduce aeration.

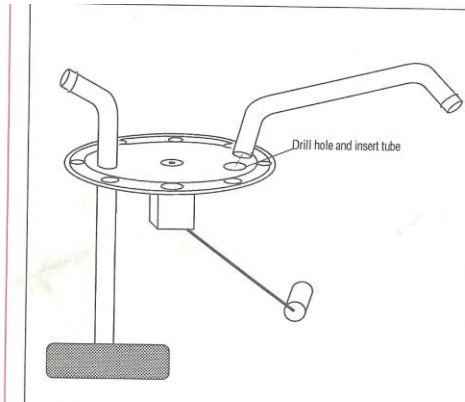

**Figure 7**

The fuel return tube must be bent away from the fuel pickup so that the fuel supply is not aerated, which would cause fuel pump cavitation.

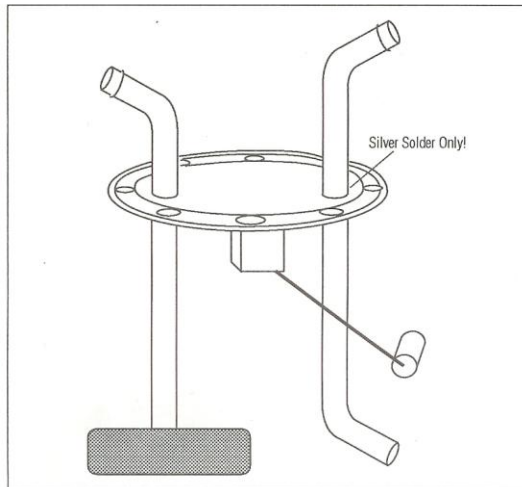

**Figure 8**

After removing the fuel gauge sending unit:

1. Locate an area to install the return tube that will clear the fuel sending float and fuel pickup line.
2. Fuel return tube must be a minimum of a 5/16" OD (outside diameter). Preferably 3/8" OD for high performance use.
3. Measure return tube outer diameter and drill a hole in sending unit  
**For a snug fit;** fuel line OD sizes will vary. Use a tube flaring tool to put a double flare on the external end of the line.(Figure 7)
4. Position the tube away from fuel pick and temporarily secure for Soldering . (Figure 8).
5. Silver solder tube to sender assembly. Silver solder is required for a Clean strong joint (radiator shops specialize in silver soldering).
6. Reinstall sending unit.



## Fuel Pump Installation

1. Carefully plug fuel lines or clamp off with line clamp. Remove Existing fuel pump and push rod where applicable and install a block off plate. **(DO YOU HAVE THIS PLATE?)**
2. Locate fuel pump and primary filter and their respective clamps. After determining the optimal location for this assembly, mark the frame through the holes in the clamps. Drill a hole for the bolt  
For the fuel pump clamp.
3. Assemble fuel pump & primary filter using the rubber hose and Clamps as indicated. Then fasten fuel pump and primary filter assembly **to the frame** with fuel pump clamp.
4. Locate and mount the secondary filter on frame rail near O/E fuel pump, away from heat source.
5. When installing the fuel line, run the fuel line the full length of the vehicle in both directions. Fasten the fuel line properly to a rigid frame member at least every 24”.
6. Take care that the fuel line, does not protrude below the frame rails at any point, and that it’s kept as far as possible from any exhaust component.
7. Connect necessary lengths of fuel line to the ends of the primary filter and fuel pump. Then slide small hose clamps over the lines and connect the ends.
8. Install fuel pump ground wire to the negative side of the pump and ground it to the frame using the fuel pump clamp bolt and star washer.
9. Connect the red wire to plus side of fuel pump and run the other end of the wire up to engine compartment, **staying away from heat sources**. Connect the red wire to the red wire from wire harness. Secure red wire to chassis where practical and safe using tie straps or hangers.
10. Fasten down filter clamps.
11. Attach the other ends of the fuel lines (supply and return) to the fuel rails as indicated in Figure 9

12. Install O2 sensor and bung into your Exhaust system. Be sure to mount the O2 sensor as close to upright as possible to prevent condensation build up on sensor. See picture 7B.

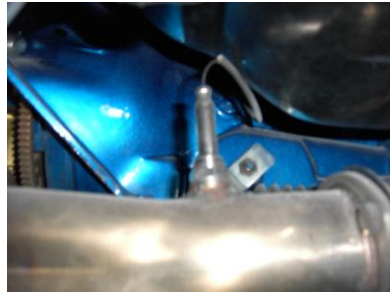

Picture 7B

### Final assembly

At this point you should review all the preceding steps and verify all of your work. This system's efficiency and reliability will be reflected by the quality of the installation. **Some time spent reviewing now may save headaches later.**

For Customer support or technical assistance, you may contact us at (262)857-3333 or email us at [FIRSTFUELINJ@AOL.COM](mailto:FIRSTFUELINJ@AOL.COM). Visit us on the web at [WWW.FIRSTFUELINJECTION.COM](http://WWW.FIRSTFUELINJECTION.COM). Your comments & suggestions are welcome. First® Performance Center LLC, PO Box 413, Bristol, WI. 53104  
1-888-857-3333

### Checklist

- Mounting Hardware
- Gaskets
- Throttle Cable Bracket
- TPS Bracket
- Fuel Rails
- Diversion Plate
- EGR Plugs & gaskets
- Manifold
- Plenum
- Throttle Body
- Runners
- Return Spring & tab

**All units are loosely assembled for shipping. Please make sure to tighten all screws**

# **First® Performance Center, LLC Warranty**

First® warrants each item of mechanical equipment sold or supplied as part of First® Fuel Injection intake System is warranted for lifetime against defects in materials and workmanship.

These are the only warranties made and all other warranties of fitness, merchantability or suitability for a particular purpose are specifically disclaimed.

Some states do not allow limitations on how long an implied warranty lasts.

## **First® Does Not Warrant:**

Products which have been modified beyond the manufacturer's recommendations.

Products which have been subject to misuse, abuse or accident.

Products which have been improperly installed.

Products which have not received normal routine maintenance as set out in the instruction booklet.

Products which have been subjected to improper fuel or to fuel containing dirt, gum, water, or other contaminants.

Products which have been damaged due to excessive high voltage.

Products used for racing.

Products supplied by other manufacturers.

## **Limitation of Remedy To Parts:**

This limited Warranty shall be limited to the repair or replacement of parts which prove to be defective under normal use. **First® performance center is NOT responsible for labor cost, just part replacement.**

If warranty work or repair parts are required contact First® at the address below for information on obtaining warranty service.

First® limits its liability to the costs of repair described above and these remedies are exclusive. First® disclaims all liability for incidental and consequential damages including, but not limited to, loss of time, loss of use, loss of profits and all other consequential damages resulting from the use of the products.

This is the only warranty offered by First® applicable to its fuel injection system. This warranty provides specific legal rights; other rights vary from state to state. Some states do not allow the exclusion or limitation of incidental or consequential damages. Initial warranty determinations will be made by First® Performance Center, LLC.

First® does not authorize any person or company to assume for it any other obligation or liability in connection with the sale, installation, use, removal, return, or replacement of its equipment; and no such representations are binding on First®.

First® may require reasonable proof of your date of purchase. Therefore, you should retain your sales slip or invoice and return the First®.

First® reserves the right to make necessary changes in the products it manufactures and markets at any time to improve product performance. These changes in products will be made without obligation to change or improve products that were previously manufactured.

FIRST® Performance Center, LLC  
PO Box 413 Bristol, WI 53104  
262-857-3333 or 1-888-862-6072  
[www.firstfuelinjection.com](http://www.firstfuelinjection.com)

Copyright© 2013 First® Performance Center, LLC  
All rights reserved

No part of this publication may be reproduced, stored in a retrieval system, or transmitted, in any form or by any means, electronic, mechanical, photocopying, recording, or otherwise, without the prior written permission of First® Performance Center, LLC. Produced in the United States of America.

First® is a trademark of First® Performance Center LLC.

Installation Manual Version 1 TPI : December 04, 2013

The information in this manual is furnished for informational use only, is subject to change without notice, and should not be construed as a commitment by First® Performance Center, LLC. First® Performance Center, LLC assumes no responsibility or liability for any errors or inaccuracies that may appear in this manual.

#### IMPORTANT NOTICE

The First® fuel injection system is designed for off road use. It is not legal in California on any pollution controlled motor vehicle. It has not been approved for marine applications.