

# *Emery Thompson*

INSTALLATION – OPERATION  
CLEANING – MAINTENANCE

## CB-350 BATCH FREEZER



**STATE LAW REQUIRES THAT THE  
ELECTRICAL POWER TO  
THIS MACHINE BE INSTALLED  
ONLY  
BY A LICENSED ELECTRICIAN**

**FAILURE TO HAVE A LICENSED ELECTRICIAN  
INSTALL THIS MACHINE WILL  
VOID YOUR WARRANTY**

**<<< CAUTION >>>**

**CB-350 COUNTERTOP BATCH FREEZER**



**<<< WARNING >>>**

**YOUR COMPRESSOR WILL IMMEDIATELY START WHEN THE  
ELECTRIC IS CONNECTED AND TURNED ON**

- 1. SECURE ALL PANELS TO THE MACHINE BEFORE TURNING ON THE ELECTRIC.**
- 2. THE OCCASIONAL CYCLING OF THE COMPRESSOR ON AND OFF IS NORMAL AND IS DESIGNED TO EXTEND THE LIFE OF THE CONDENSING UNIT.**

- 1 -

v. 3.21

Emery Thompson CB-350 Countertop Batch Freezer

# **TABLE OF CONTENTS**

Section 1	WARRANTY	Page 3
Section 2	SAFETY	Page 6
Section 3	UNPACKING	Page 8
Section 4	INSTALLATION	Page 9
Section 5	CLEANING & SANITIZING	Page 11
Section 6	OPERATION	Page 13
Section 7	OPERATING THE TOUCH SCREEN	Page 14
Section 8	CARE & MAINTENANCE	Page 24
Section 9	DESCRIPTION OF FUNCTION	Page 26
Section 10	ELECTRICAL DIAGRAM	Page 27
Section 11	TROUBLESHOOTING	Page 28
Section 12	PARTS DIAGRAMS	Page 31
Section 13	RECIPES	Page 33

## **Section 1 – WARRANTY**

### Emery Thompson Machine and Supply Company, Inc. 12 Month Limited Warranty on New Freezers

**Notice: The machine warranty starts when you receive your machine.**

Except as limited and conditioned hereafter, The Emery Thompson Machine and Supply Company, Inc. (hereinafter referred to as the “Company”) warrants to the original purchaser and user only, the said machine and all parts thereof to be free from defects in material and workmanship for a period of twelve (12) months from the **date of shipment** from the Company’s factory if it is proved to our satisfaction to be inoperative due to defects in material or factory workmanship. Caution: This warranty is valid only if required service is provided by an authorized agent of Emery Thompson Machine and Supply Company or person or persons directly authorized by Emery Thompson to perform the necessary repairs. Emery Thompson can be reached at 718-588-7300-factory, 352-796-0720-fax or **STEVE@EMERYTHOMPSON.COM** electronic mail.

**Definitions.** The term “original purchaser” as used herein, shall be deemed to mean that person, firm, or association, or corporation for whom the equipment referred to herein is originally sold to. The term “Company and or Factory” shall mean the plant of the company located at 15350 Flight Path Drive, Brooksville, FL 34604 U.S.A.

**Labor and Transportation Charges.** Emery Thompson Machine and Supply Company assumes no liability under the warranty for any transportation charges or labor expenses incident to its work under this warranty, such transportation expenses and labor costs to be assumed and paid by the Purchaser.

**Use and Care of Machine.** Purchaser shall only use the machine in accordance with the operator’s manual provided by the Company and no liability under this Warranty or otherwise shall attach by reason of a defect caused by negligence, abnormal use, misuse or abuse of said machine, or for any accident that may occur to said machine or any part thereof after said

machine has left the factory of the Company, nor for any defect that may arise by placing any part in said machine which has not been manufactured or approved by the Company. Misuse of the machine includes owner's failure to: (1) clean, lubricate and assemble per the Operator's Manual; (2) replace damaged or worn "wear items", including but not limited to o-rings, gaskets, front bearing, rear bearing, scraper blades, drive shaft, water valve. (3) handle parts properly, resulting in breakage; or (4) use unauthorized service agencies.

**Purchaser shall not remove, alter or deface the serial number on said machine and there shall be no liability of Emery Thompson Machine and Supply Company if any of same shall occur.**

**Repair or Replacement of Defective Parts.** The Company's obligation under this warranty is limited to the repair of defective parts at the Brooksville, Florida plant or replacement from the Company's own inventory. In the event the Company ships a replacement part prior to the return of the defective part, payment will be required for said part and credit issued or reimbursement made **only if the defective part is returned within thirty (30) days from replacement date.**

**WARNING: The use of alternate refrigerants will void your warranty. Use only the refrigerant specified on this unit's data plate (located on rear panel of machine).**

**Emery Thompson Machine and Supply Company, Inc. reserves the right** to make design changes, or to make additions to, or improvements on its products without imposing any obligation on itself to make such changes on its products previously manufactured.

THIS WARRANTY IS EXCLUSIVE AND IS IN LIEU OF ALL OTHER WARRANTIES AND REMEDIES UNDER THE LAW, INCLUDING ANY IMPLIED WARRANTY OF MERCHANTABILITY OR FITNESS FOR A PARTICULAR PURPOSE. THE ORIGINAL OWNER'S SOLE REMEDY WITH RESPECT TO ANY EMERY THOMPSON FREEZER SHALL BE REPAIR OR REPLACEMENT OF DEFECTIVE COMPONENTS UNDER THE TERMS OF THIS WARRANTY.

WHAT IS NOT COVERED BY THIS WARRANTY Emery Thompson Machine's sole obligation under this warranty is limited to either repair or replacement of parts, subject to the additional limitations below. This warranty neither assumes nor authorizes any person to assume obligations other than those expressly covered by this warranty. NO CONSEQUENTIAL DAMAGES. EMERY THOMPSON IS NOT RESPONSIBLE FOR ECONOMIC LOSS; PROFIT LOSS; OR SPECIAL, INDIRECT, OR CONSEQUENTIAL DAMAGES, INCLUDING WITHOUT LIMITATION, LOSSES, OR DAMAGES ARISING FROM FOOD OR PRODUCT SPOILAGE REGARDLESS OF WHETHER OR NOT THEY RESULT FROM REFRIGERATION FAILURE. WARRANTY IS NOT TRANSFERABLE; this warranty is not assignable and applies only in favor of the original purchaser/user to whom delivered. ANY SUCH ASSIGNMENT OR TRANSFER SHALL VOID THE WARRANTIES HEREIN AND SHALL VOID ALL WARRANTIES, EXPRESS OR IMPLIED, INCLUDING ANY WARRANTY OF MERCHANTABILITY OR LABOR COVERAGE FOR COMPONENT FAILURE OR OTHER THE WARRANTY AS PROVIDED IN OUR INSTRUCTION MANUAL WITH THE UNIT AND AT [www.emerythompson.com](http://www.emerythompson.com). EMERY THOMPSON will not be held responsible for the following external factors: ALTERATION, NEGLIGENCE, ABUSE, MISUSE, ACCIDENT, DAMAGE DURING TRANSIT OR INSTALLATION, FIRE, FLOOD, ACTS OF GOD, OR IMPROPER ELECTRICAL CONNECTIONS. EMERY THOMPSON IS NOT RESPONSIBLE FOR THE REPAIR OR REPLACEMENT OF FAILED OR DAMAGED COMPONENTS RESULTING FROM ELECTRICAL POWER FAILURE, THE USE OF EXTENSION CORDS, LOW VOLTAGE, OR VOLTAGE DROPS TO THE UNIT. THERE ARE NO IMPLIED WARRANTY OF MERCHANTABILITY OR FITNESS FOR A PARTICULAR PURPOSE.

NO DISTRIBUTOR, DEALER OR OTHER PERSON IS AUTHORIZED TO MAKE ANY COMMITMENT OR ASSUME ANY LIABILITY ON BEHALF OF EMERY THOMPSON MACHINE AND SUPPLY COMPANY, INC. BEYOND THIS WARRANTY. THERE ARE NO WARRANTIES, WHICH EXTEND BEYOND THE DESCRIPTION ON THE FACE HEREOF.

## **Section 2 – SAFETY**

First, be sure to read and understand this machine manual, and familiarize yourself and other operators with the machine features, its operation, cleaning, and maintenance.

Your machine is equipped with several important safeguards that should never be removed or altered. DO NOT remove the following items:

- Inlet spout combination lid and gate – restricts fingers from coming in contact with moving blades/dasher.
- Door discharge guard – restricts fingers and utensils from coming in contact with moving blades/dasher. Also, in combination with the discharge chute, funnels product into smaller containers neatly.

The sides, front, and rear section of the machine have ventilation openings in them. All but the rear panel are louvered to deflect food and splashing liquids away from the inside. Never spray water directly at/into these openings.

If your machine is set up with a plug on the end of its cord, make absolutely sure your hands are dry when plugging it in, or unplugging it. When operating the machine, avoid distractions such as conversations, television, small children, etc.

The door and the dasher are heavy parts and are slippery when wet. Use extreme care handling them. Keep the floor and work area neat and dry to avoid slippage. Do not use the top of the machine as a storage spot.

In addition to the above:

- DO NOT operate your machine unless it was wired, grounded, and properly fused by a licensed electrician.
- DO NOT put fingers, hands or any utensils in either the inlet spout or door outlet.

- DO NOT operate the machine unless it is properly assembled and all guards are in place.
- DO NOT force any of the (washable) parts together or into/on the machine. All parts should fit together easily.
- DO NOT operate the machine with the freezing cylinder empty.
- DO NOT turn on the machine's refrigeration switch with only water in the freezing cylinder.
- DO NOT let your product over-freeze during production. This is the most common mistake a new operator makes.



## **Section 3 – UNPACKING**

Carefully inspect the pallet and shipping carton for any signs of damage during shipment; if damage is suspected, have the freight company note it on the bill of lading, and if possible, take photographs.

The shipping carton is stapled to two wooden runners inside\*. Using a razor knife, carefully cut through the carton all the way around its perimeter JUST ABOVE the staple line. The carton is approx. ½” thick. Once free, the carton should be lifted straight up and off of your machine. You will find a small box of parts that will be explained in subsequent sections; set them, as well as all paperwork, aside in a safe place.

The machine is bolted to the pallet it was shipped on from the underside. There are four hex bolts (9/16” head) that go through the upper planks of the pallet, and into the machine frame. Remove all four bolts, and also unscrew one wooden side runner from the pallet. The machine will now be free from the pallet. Save all components; they can be used at a later date to safely move the machine.

\* If your machine was exported outside of North America, it will have an all wood box over it fastened to the runners with removable screws.

## **Section 4 – INSTALLATION**

Your new machine weighs 275 pounds and has momentum when running; therefore, it must be operated on a surface/stand/counter capable of supporting it. It will take a minimum of two people to safely lift it.

In the smaller carton that was included with the machine, there are 4 screw-in feet; these should be installed into the threaded holes on the underside of the machine's frame, where it was previously bolted to the shipping pallet. These allow for minor uneven surfaces.

NOTE: If you also purchased the heavy-duty machine stand, you will not be using these feet; follow instruction in the kit that comes with the stand.

The stainless-steel shelf clips onto the louvers on the front lower panel; it is adjustable for various height containers/trays.

NOTE: The protective plastic film on most outer surfaces of the machine protects the finish during shipping. This film **MUST** be removed prior to operation of the machine to allow proper airflow and heat dissipation.

The machine **MUST** be able to pull in cool, clean room air from its rear intake. It requires a minimum of 10 inches of clear, unobstructed space on all 4 sides. Failure to allow the adequate spacing and/or not removing the protective plastic film may result in poor performance, overheating, and shutdown.

**ELECTRICAL CONNECTION:** The model CB350 machine comes with a 72 inch long flexible power cord that has an L14 - 20 locking male plug installed on it. It **MUST ONLY** be connected to a matching receptacle which has been wired to a dedicated and fused 20-amp circuit. Your machine has a wiring tag on its cord, as well as electrical specifications on its serial number tag on the rear of the machine. Your electrician can also call us for technical information if necessary, during business hours.

**IMPORTANT NOTE: This machine will not work if it is connected to a GFCI circuit. If the local electrical code requires that the machine be connected to a GFCI circuit, contact Tech Support at Emery Thompson for further instructions.**

## **Section 5 – CLEANING & SANITIZING**

**NOTE:** Your local or state health inspector will always have jurisdiction over the methods and cleaners he/she prefers for the proper cleaning and sanitizing of this type of equipment. Our instructions are based on industry standard methods but should be discussed with your inspector.

The first step toward insuring a clean and sanitary machine is to understand the various parts that will or could come in contact with the food product. Please see Diagrams 1A (Page 31) and 1B (Page 32) to familiarize yourself with these parts.

All of these parts are dishwasher safe and relatively small, so the easiest way to clean them is to carefully arrange them in a dishwasher, positioning them so that open holes, pockets, and internal areas face down and stand the best chance of being hit with hot soapy water. Any of these parts can also be cleaned with liquid dish detergent and hot water, so long as they are thoroughly rinsed. The inside of the cylinder will have to be manually wiped out with warm soapy water and thoroughly rinsed.

The following list of components should be cleaned at the end of the day/shift, or if food product has sat in the machine for one hour or more:

- all parts on diagram 1A
- all parts on diagram 1B, except “ASSY006”, part 1 and 3 (these parts are inaccessible, and do not come in contact with food). Part #2 of this assembly protrudes into the freezer and should be cleaned/wiped when cylinder is cleaned.

Prior to each use your machine must be sanitized. The purpose of sanitization is to kill any bacteria that may have grown on any food-contact part or surface.

To properly sanitize your machine, it must first be reassembled after cleaning. Before putting the dasher/blades assembly back into the machine, note the end of the dasher shaft has two o-rings in it. These two o-rings, and the circumference of the shaft just forward and rearward of the o-rings should have a generous coating of food-grade

grease wiped on them (See diagram 1B/Dasher shaft, and Part 6 O-Rings, Page 32). Once installed, any grease pushed off the shaft can be wiped off with a paper towel. NOTE: Before installing dasher/blade assembly into cylinder, ensure that the rounded end of each scraping blade is toward the rear. (See Diagram 1B, Page 32.)

When the machine is fully assembled, with the door in place, and the four knobs hand tightened (do NOT use any tools), it is ready to be sanitized.

We recommend using a commercially available sanitizer/cleaner made by Purdy Products Company called “Stera Sheen Green Label”, although other brands exist as well. Carefully follow the manufacturer’s instructions on mixing and use of their product.

## **Section 6 – OPERATION**

Your new batch freezer is very easy to operate, with only two controls on it. The machine was shipped fully assembled, and its' parts and features should be learned and understood.

On the upper right of the face of the machine, there is a pushbutton switch. This energizes the refrigeration condensing unit. Push in the button for “on” and push in on the button for “off”. In the “on” position, the button will illuminate blue. Ensure that the button is in the “off” position.

When electrical power is first applied to the machine, the compressor will immediately start, regardless of the position of the refrigeration button. The compressor will also start occasionally and run briefly, even if the machine sits idle if there is power connected to it. This is a normal function, and actually helps prolong the life of the compressor.

## **Section 7 – OPERATING THE TOUCHSCREEN**

The CB-350 touchscreen is a powerful device filled with intuitive operating screens and helpful videos. This section will explain how to navigate the screens for safe and proper operation of the machine.

### **7.1 The SCREEN SAVER**

After applying power to the machine, the SCREEN SAVER screen displays the rotating ET symbol. To begin operating the machine or to watch a help video, touch the screen. The screen saver will appear after 1 minute of the screen not being touched, unless the RUN screen is active.



## 7.2 The I WANT TO: Screen (Also called the HOME screen)

After touching the screen, the I WANT TO:/HOME screen is displayed. You can choose to MAKE ICE CREAM or GET HELP. Press the MAKE ICE CREAM button.



## 7.3 The CHOOSE RECIPE Screens

If you selected MAKE ICE CREAM from the I WANT TO:/HOME screen, the next screen you will see is the CHOOSE RECIPE screen. This screen allows the operator to choose the desired amount of overrun by the product name. (See the Overrun/Product/Speed chart on page 11, section 5.4.) This is the first screen of two CHOOSE RECIPE screens. Press the MORE RECIPIES button to go to the second screen or press the HOME button to go back to the I WANT TO:/HOME screen.





When you are on the second CHOOSE RECIPE screen, you can press the PREVIOUS RECIPIES button to return to the first CHOOSE RECIPE screen or you can press the HOME button to go back to the I WANT TO:/HOME screen. Press the button that corresponds to the product you want to make on either screen and you will be taken to the START screen for that product.



#### 7.4 The OVERRUN/PRODUCT/SPEED Chart

### OVERRUN/PRODUCT/SPEED

Desired Overrun (%)	Product Name	Dasher Speed (RPM)
100	Homemade	234
65	Super Premium	165
65	Frozen Yogurt	160
50	Gelato	140
40	Cream Ice	200
40	Sherbet	200
35	Custard	135
30	Dairy Free	160
15 – 17	Italian Ice	234
15 – 17	Sorbet/Sorbetto	234
15	Frozen Lemonade	234

## 7.5 The START Screen

On the START screen you will find the name of the product you have selected at the top, and the speed that the dasher will turn in the middle of the two circles, when the START button is pressed. You will also find the MANUAL SPEED UP and DOWN buttons. These buttons can be used to adjust the dasher speed up and down as desired. The speed will change in 5 RPM increments each time the button is pressed. You will also see the status of the blades where it says BLADES STOPPED. The HOME button will take you back to the I WANT TO:/HOME screen and the BACK button will take you back to the CHOOSE RECIPE screen.



## 7.6 The RUN Screen

When the START button is pressed, the RUN screen is displayed, and the dasher and scraper blades begin to spin. You will see that the START button changes to a STOP button, the blades animation begins spinning, and the BLADES STOPPED message changes to BLADES SPINNING. The MANUAL SPEED UP and DOWN buttons can be pressed to change the speed of the dasher if desired. Once the FREEZE switch is pressed, the BACK button in the upper right-hand corner of the screen changes to a timer and begins to count up. This timer can be used to monitor the time that a batch has been running. The timer stops and resets to 0:00 when the FREEZE switch is turned off. When the STOP button is pressed, the dasher stops and the screen changes back to the START screen.

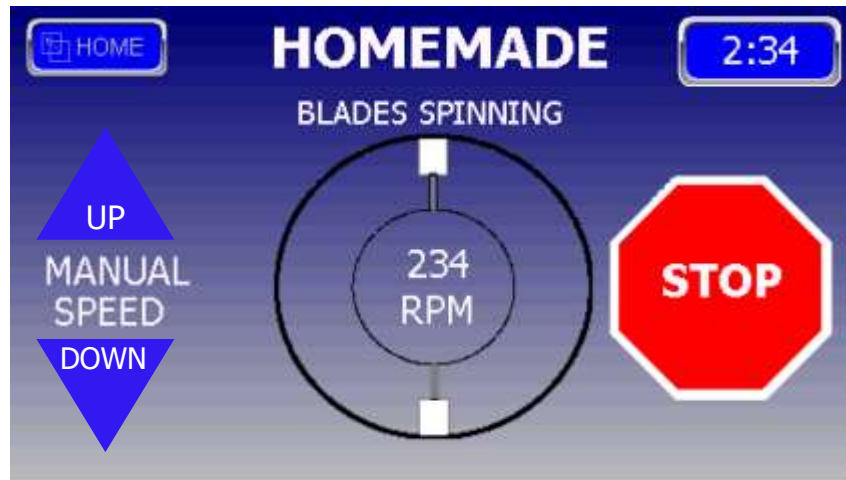

## 7.7 The GET HELP Screens

From the I WANT TO:/HOME screen, press the GET HELP button, which will take you to the SELECT YOUR MACHINE screen.



## 7.8 The SELECT YOUR MACHINE Screen

Touch the picture of the machine that matches the machine you want to get help with, and you will be taken to the HELP VIDEOS menu for your machine. If you want to go back to the I WANT TO:/HOME screen, press the HOME button.



## 7.9 The HELP VIDEOS Screen

From the HELP VIDEOS menu, you can select the category of help you need. You can choose SETUP, OPERATION, MAINTENANCE and TROUBLESHOOTING topics. Also, you can press the HOME button to be taken back to the I WANT TO:/HOME screen or the BACK button to go back to the SELECT YOUR MACHINE screen.



The rest is self-explanatory and very easy to navigate. Simply choose a topic, press the button for the video of your choice, and watch the video.

## 7.10 The ALARM Screens

If the dasher motor speed controller experiences a problem, an alarm screen will be displayed. There are two different alarm screens that may be displayed: COMMON ALARMS and OTHER ALARMS. Some alarms can be cleared by pressing the RESET button, while others may cause the dasher to stop turning, and soon thereafter, the refrigeration system to shut down. Pressing the REMEDY button will provide information for resolving the problem that caused the alarm. If the machine stops due to one of these alarms, it is important to take note of the alarm and call Tech Support at Emery Thompson if the alarm persists. If the alarm cannot be cleared by pressing the RESET button, turn off the power to the machine for 30 seconds and turn it back on.



## 7.11 The WARNING Screen

As the product mixes in the cylinder, the product gets constantly thicker. As the product gets thicker, the power required to drive the dasher motor increases. As the power to drive the dasher motor increases, the IOC monitors its output power to ensure that it does not rise to a level that will damage the dasher motor. If the output power reaches the preset high level, the WARNING screen will be displayed, and an audible alarm will begin to sound. If this happens you should press the ACKNOWLEDGE button, turn off the FREEZE switch and begin to extract the product. Pressing the ACKNOWLEDGE button will cause the screen to display the RUN screen and cause the audible alarm to stop. If the product is not extracted the WARNING screen will come back on 30 seconds after the ACKNOWLEDGE button was pressed. This will continue to happen until the IOC shuts itself off.



## 7.12 The SYSTEM Screen

The touchscreen requires an operating system just like a computer. There is no reason for the user to access the SYSTEM screens, but you should be aware that they exist as it is possible to call up the screens accidentally. The SYSTEM screens will appear if you touch the screen in the upper right-hand corner. If the system screen is accidentally displayed, touch the screen anywhere outside the SYSTEM screen area to close the screen, or wait 1 minute and it will go off on its own.





## **Section 8 – CARE & MAINTENANCE**

One of the best features of an Emery Thompson batch freezer is the small amount of maintenance and the ease of care required. The materials we use are the best available for their intended purpose and designed for maximum longevity.

The outer casing of your machine is all heavy-gauge stainless steel, and will only require a daily wipe down, using a mild detergent and warm water. A stainless-steel cleaner/polish can also be used to keep it bright.

Performing regular maintenance on your Emery Thompson batch freezer will keep it running at its peak performance for many years. The maintenance required is based on how frequently you run the machine and how long you run the machine. It is easiest to think of this as how many hours per week (HPW) you run the machine. Example: If you run the machine 3 days a week for 4 hours each day, the machine is actually running 12 hours per week. The more hours per week you run your machine the more frequently you should perform maintenance. See the chart below for routine maintenance subjects and the frequency with which they should be performed.

	<b>0 to 15 HPW</b>	<b>15 to 30 HPW</b>	<b>30 to 45 HPW</b>	<b>More Than 45 HPW</b>
<b>Lubricate the Dasher/Center Shaft O-rings</b>	Every time you run the machine or after 8 hours of continuous operation	Every time you run the machine or after 8 hours of continuous operation	Every time you run the machine or after 8 hours of continuous operation	Every time you run the machine or after 8 hours of continuous operation
<b>Lubricate the Discharge Gate O-ring<sup>(1)</sup></b>	Daily	Daily	Daily	Daily
<b>Lubricate the Door O-ring</b>	Never	Never	Never	Never
<b>Replace the Dasher/Center Shaft O-rings</b>	Once each year	Every 9 months	Every 6 months	Every 3 months
<b>Replace the Discharge Gate O-ring<sup>(1)</sup></b>	Only if it leaks	Only if it leaks	Only if it leaks	Only if it leaks

<b>Replace the Door O-ring</b>	Only if it leaks	Only if it leaks	Only if it leaks	Only if it leaks
<b>Replace the Blade Springs</b>	Every 2 years	Every 18 months	Once each year	Every 6 months
<b>Replace the Door Gate Spring(s)</b>	Only if it leaks	Only if it leaks	Only if it leaks	Only if it leaks
<b>Sharpen the Scraper Blades</b>	Every 5 to 7 years	Every 4 to 6 Years	Every 3 to 5 years	Every 2 to 4 years
<b>Replace the Scraper Blades</b>	After sharpening 1 to 3 times	After sharpening 1 to 3 times	After sharpening 1 to 3 times	After sharpening 1 to 3 times
<b>Inspect/Clean the Drip Tray<sup>(2)</sup></b>	Once each Year	Every 9 months	Every 6 months	Every 3 months
<b>Drain the Water<sup>(3)</sup></b>	Every year prior to possible freeze	Every year prior to possible freeze	Every year prior to possible freeze	Every year prior to possible freeze
<b>Clean the Cooling Coils<sup>(4)</sup></b>	Once each year	Every 9 months	Every 6 months	Every 3 months

- (1) CB-200 and CB-350 machines only
- (2) 12, 24- and 44-quart machines only
- (3) Water cooled machines only
- (4) Air cooled machines only

If your batch freezer has been stored in an unheated area and is brought into a warmer area for use, allow it to sit for at least 24 hours in the warmer temperature; condensation can build up on cold surfaces, including inside the speed controller, touchscreen, contactor, and overload relay, which could lead to malfunctions.

Never transport, store or use your machine in any position other than upright on its feet. Oil in the refrigeration compressor could travel into areas of the machines piping where it will remain trapped.

Your machine has been tested and is rated to run in ambient air temperatures as high as 104 degrees Fahrenheit, and as low as 40 degrees Fahrenheit. Operation in temperatures at the high end of the temperature range may slightly increase the freezing time of your product, and at the low end of the temperature range may slightly decrease the freezing time of the product.

## **Section 9 – Description of Function**

The purpose of this section is to explain how the CB-350 is supposed work so that anyone working on the machine will have a thorough understanding, which should make troubleshooting easier. Please refer to the electrical drawing on the next page for the reference numbers in parentheses.

With main power present at the machine, the touchscreen (1) should be active, and the refrigeration button (2) should be in the off position.

When a product is selected on the touchscreen and the start button is pressed, the dasher motor speed controller (3) sends power to the dasher motor (4) and the dasher motor runs at the speed pre-programmed for that product. Also, the auxiliary contacts 10 and 11 on the dasher motor speed controller (3) close completing that portion of the circuit that is in series with the refrigeration button (2) and the high- and low-pressure switches (6, 7).

With the dasher motor running and the refrigeration button turned on, the solenoid valve (5) on the high-pressure side of the refrigeration system is energized and CR-1 (11) is energized. When the contacts in CR-1 close, the refrigeration button lights up and input Q1 on the touchscreen becomes true, which starts the timer on the touchscreen.

When the solenoid valve opens, and the pressure builds above 40 psi on the low-pressure side, the low-pressure switch (6) closes. (The high-pressure switch (7), which, is in series with the low-pressure switch, will be closed and will only open if the pressure goes above 400 psi, which is the set point of the high-pressure switch.

When the low-pressure switch closes, the coil (8) to the motor contactor (9) is energized and the condensing unit and cooling fan (10) begin to run.

As the condensing unit runs, the refrigeration coils wrapped around the product cylinder begin to get cold.

Ideally the low-pressure side should drop to 28 to 32 psi and the high-pressure side should run at 275 to 325 psi. During the last several minutes of a batch you may see the low-pressure side drop again by about 2 psi.

When the product is ready, the refrigeration button is turned off and the solenoid valve closes and the contacts in CR-1 open. The compressor continues to run until the low-pressure side of the refrigeration system drops below 10 psi and the low-pressure switch opens.

When the low-pressure switch opens, the coil is no longer energized, and the motor contactor opens causing the condensing unit and cooling fan to stop.

When the STOP button on the touchscreen is pressed, the dasher motor speed controller stops sending power to the dasher motor and the motor stops.

## Section 10 – Electrical Diagram

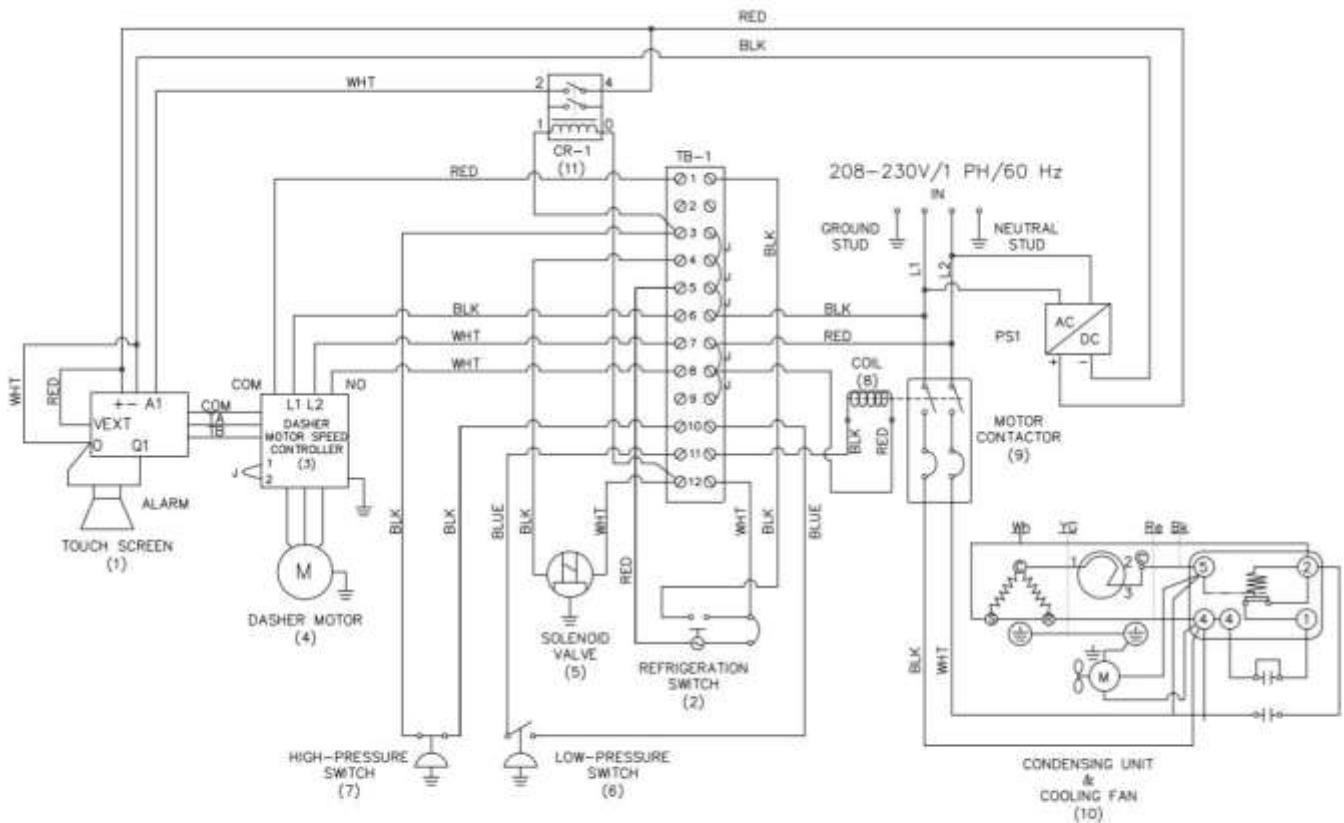

**CB350  
HIGH VOLTAGE SCHEMATIC**

## Section 11 – TROUBLESHOOTING

### **YOUR FROZEN DESSERTS**

#### **(FREEZING UP YOUR MACHINE)**

##### **What you did wrong!**

When our customers first run their new Emery Thompson CB-350, what we too often hear is how they froze the machine up solid and got an error code on the touchscreen.

Here is a list of what went wrong:

1. They did not read the instruction manual. Unlike a cell phone (that does not come with an instruction manual), your \$11,500.00 investment comes with a very comprehensive manual. Your new batch freezer is not “Intuitive.” You must read and understand the entire instruction manual – and especially read the warnings! It’s a lot of money to spend and not operate it properly.
2. If the scraper blades (the two long pieces of Delrin plastic) are not installed properly, the machine will start making noise in a few minutes and either freeze up or take three times as long to make a batch. The curved tip of the blade goes to the back of the machine and the other tip of the blade which is cut off on a 90 degree angle goes to the front of the machine. We have added a



"dimple" to the very front of each blade.

After the dasher is in place, you should be able to see the "dimple" on each of the two blades BEFORE you put the front door in place (see photo). If this is wrong the machine will not operate properly. You need to be aware of this Each and Every time you assemble the machine.

3. You cannot do “test” half batches. You must have three and a half to four quarts of product in the freezing cylinder for the CB-350 in order to make a batch. Less than this will freeze up the machine! Do not turn on the refrigeration switch with only water in the machine. Water is not a dairy blend nor is it a water ice. No sugar or no dairy and your machine will freeze up solid.
  
4. YOUR BLEND: You’re going to have to trust me on this one – I’ve been building and running Emery Thompson Batch Freezes since I was sixteen years old. Your “blend” which came from a magazine, cookbook or you made it up will work fine in your home ice cream freezer or a cheap Italian or Chinese machine. Why? Because it takes a very long time to freeze – 40 minutes or more as compared to ¼ of that time in your new Emery Thompson. And it has little or no freezing capabilities beyond your home refrigerator. Your Emery Thompson has tremendous freezing ability. But without the proper level of solids, your recipe is going to freeze up in a modern piece of dairy equipment. Solids come in the form of sugars, cream and some nuts like cashews. Splenda, Stevia and Xylitol have no solids. Milk does not have enough solids. Coconut water has virtually no solids. Cream of Coconut does. While you can use all these products in your formula, they alone will not freeze. You are welcome to call us, and we can discuss your formula with you... but physics and the laws of freezing cannot be changed. Water and flavor do not alone make a sorbet and milk alone does not make an ice cream.

Also see our online Help Desk at  
<http://www.emerythompson.com/HelpDesk.htm>  
for instant access or call 718-588-7300.

<b>Problem</b>	<b>Solution</b>
Dasher not spinning	Contents frozen too stiff – allow to thaw and soften or remove bulk of product. Push “stop” button, and attempt restart.
Dasher spins, but refrigeration will not run. (refrigeration switch illuminated)	Compressor has tripped off. Turn off switch; allow unit to cool for 1 hour minimum; attempt restart.
Unit runs, but takes too long, or longer than usual to freeze product.	Airflow restricted or coils dirty/blocked. Provide adequate airflow and/or clean coil area.
Squeaking noise when dasher runs.	Insure that dasher shaft has been lubricated properly at o-ring area.
Grinding noise while making product; build-up on cylinder walls.	Blades installed incorrectly; one or more blade springs missing.
Sliding gate is leaking	O-ring on gate is either not in gate groove or worn out; surfaces not lubricated correctly.
Door will not pull back on studs; blades sticking out beyond face.	Rear of dasher is not engaged into drive motor socket. Rotate dasher and push backward.
Machine sways/shakes while running	Feet or mounting surface uneven; adjust feet so that each has equal pressure.
Door is leaking around edge(s)	Door seal O-ring uneven/not fully seated in its groove. Remove and reinstall

## Section 12 – PARTS DIAGRAMS

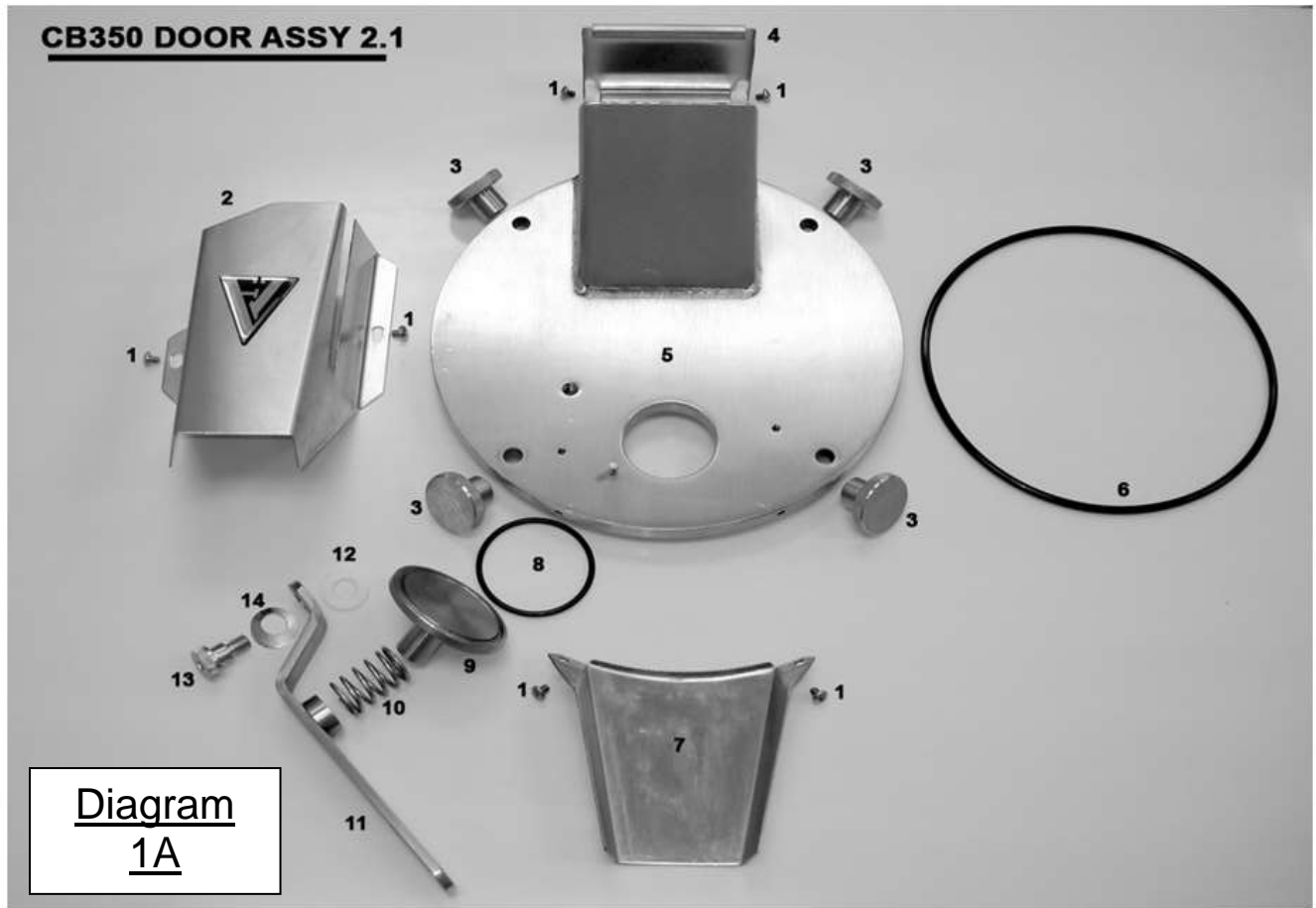

1	FAST025	screw, #10-24 x 1/4" long, 18-8 SS Phillips head (6X PER DOOR)	8	SEAL007	o-ring, CB350 gate
2	STML005	guard, door discharge, 18 ga. 304 sheet metal	9	MECH007	discharge cover, sliding (gate)
3	FAST015	knob, knurled ss, 3/8"-16 blind threaded (4X PER DOOR)	10	SPRG004	spring, discharge cover pressure, CB350, SS
4	STML004	cover, spout inlet guard, 18 ga stainless steel	11	MECH010	handle, discharge cover sliding, 303 ss
5	MECH008	door, w/spout, polished 303 ss	12	FAST024	washer, Teflon, door handle swivel
6	SEAL008	o-ring, CB350 door seal	13	FAST011	shoulder bolt, door handle, 1/2" diam. 18-8 stainless steel
7	STML012	chute, discharge, 12 and 24 quart and CB350	14	FAST071	washer, spring pressure



## CB350 MIX ASSY 2.0

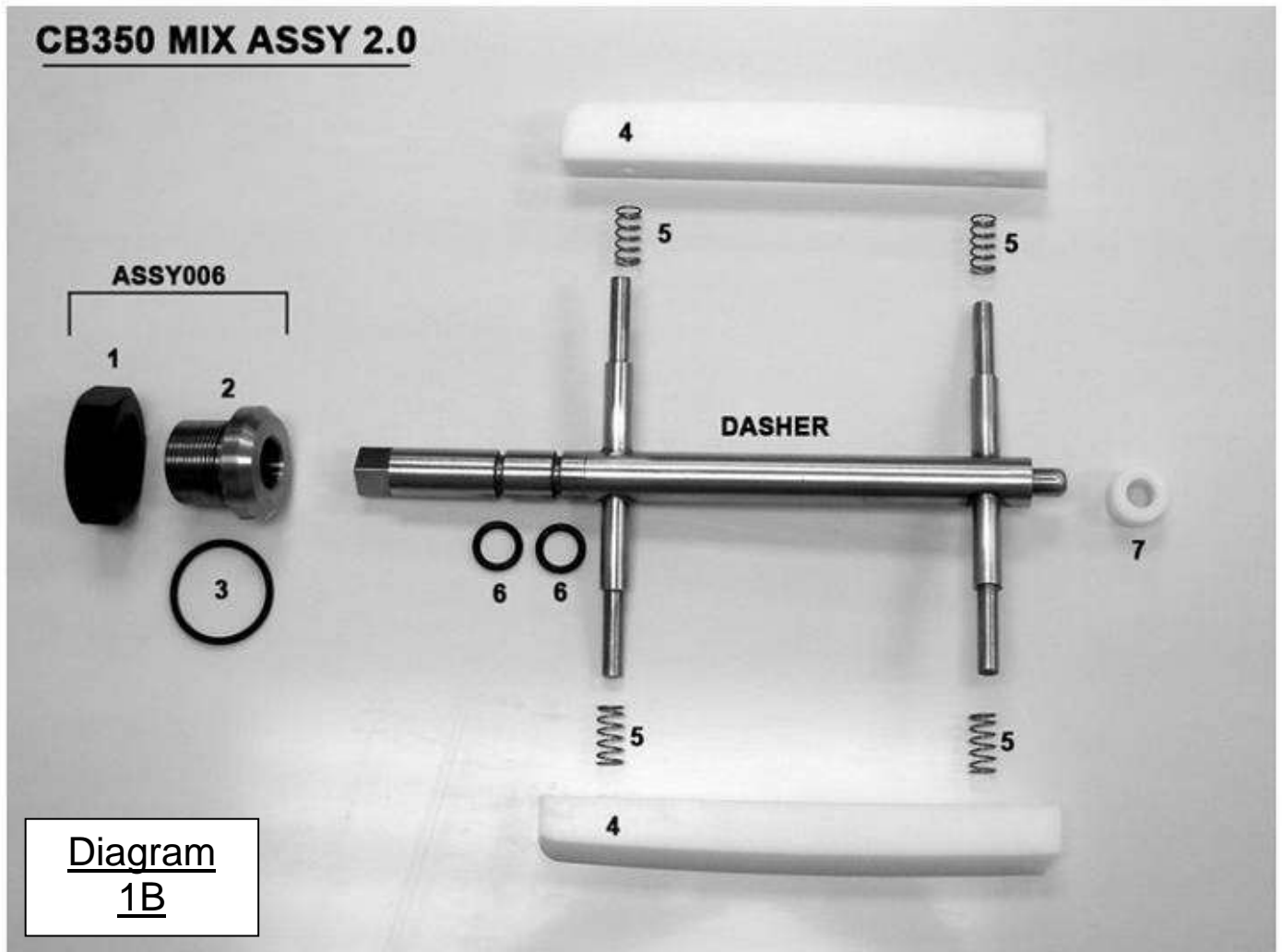

Diagram  
1B

	ASSY006	kit, CB350 back jacket bushing replacement
1	FAST009	nut, 1 1/2"-12 left-hand, black <u>Delrin</u> , CB350
2	BUSH009	bushing, back jacket, CB350
3	SEAL005	"Not Serviceable" - Part of BUSH009
4	BLAD001	blade, solid <u>Delrin</u> , CB350 machines <b>(2X PER MACHINE)</b>
5	SPRG001	blade spring, CB350 machines <b>(4X PER MACHINE)</b>
6	SEAL006	o-ring, CB350 dasher shaft <b>(2X PER MACHINE)</b>
7	BRNG001	bearing, dasher shaft front, white <u>delrin</u> , CB350
7		
7		
8		
9		
10		

## **Section 13 – RECIPES**

The following recipes are very basic, and require few ingredients, but are a good starting point to familiarize yourself with freezing times and consistencies, as well as begin to form a production routine. Again, NEVER put undissolved sugar into your machine for any recipe.

### Lemon Ice

- 4 quarts of cool tap water
- 2 pounds of sugar
- Zest grated from 2 large lemons
- 20 ounces of fresh-squeezed lemon juice

Mix the sugar with the water in a clean container until the sugar is dissolved. Slowly pour this into your CB350 machine. Add the lemon juice and lemon zest; start the dasher and set at 234 RPM. Then turn on the refrigeration and freeze for 8-10 minutes, depending on desired consistency. Store and serve at 16 degrees F.

### Coffee Ice Cream

- 3 quarts 14% ice cream mix
- 1 ounce of vanilla extract
- 2 ounces Taster's Choice instant coffee crystals
- Hershey's chocolate syrup to taste

Pour first three ingredients into machine and start dasher. Turn on refrigeration and freeze for 10-12 minutes. Add chocolate syrup approximately one tablespoon at a time to taste (takes away bitterness of coffee).

### Bordeaux Wine Sorbet

- 2 pounds of sugar
- 2 bottles (750 ml) red Bordeaux wine
- Two 750 ml bottles of tap water
- Three 12-ounce bags of red raspberries
- (optional) 4 grams of stabilizer

Mix the sugar with the water in a clean container until the sugar is dissolved. Slowly pour this and the remaining ingredients into the machine; start dasher, then the refrigeration. Freeze for approximately 10 minutes (makes  $\frac{3}{4}$  of a batch)

### Fresh Mango Sorbet

- 2 pounds of sugar
- 4 Quarts of tap water
- 3 pounds of fresh mango
- juice of one lemon

Mix the sugar with the water in a clean container until the sugar is dissolved. Slowly pour this and the remaining ingredients into the machine; start dasher, then the refrigeration. Freeze for approximately 12 minutes.