

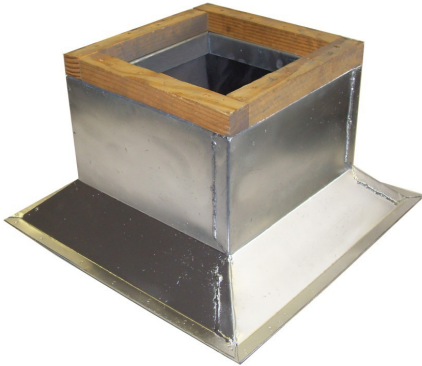

## CANTED CURB



**MODELS:**  
**LS-SC (STEEL)**  
**LA-SC (ALUMINUM)**

### APPLICATION

The LS-SC/LA-SC is Lloyd's canted curb. LS-SC consists of a 16 gage galvanized steel, 3lb. Density 1" thick insulation and 2"x2" nominal wood nailer. The steel insulated curb is 8" high with 1" of insulation. LA-SC consists of aluminum alloy 3003-H-14, 3lb. Density 1" thick insulation and 2"x2" nominal wood nailer. The aluminum insulated curb is 8" high with 1" of insulation.

### STANDARD CONSTRUCTION

Fabricated using 16 gage galvanized steel  
3lb. Density 1" thick insulation  
2"x2" nominal wood nailer  
Mill finish is standard  
"C" dimension=8in. (standard)  
Damper tray optional

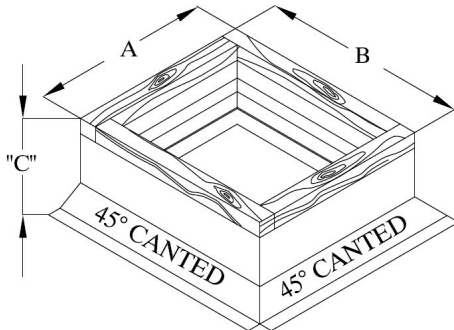

Side	Minimum Size	Maximum Size
A	6"	Contact factory
B	6"	
C	6"	

### LS-SF STEEL CANTED CURB

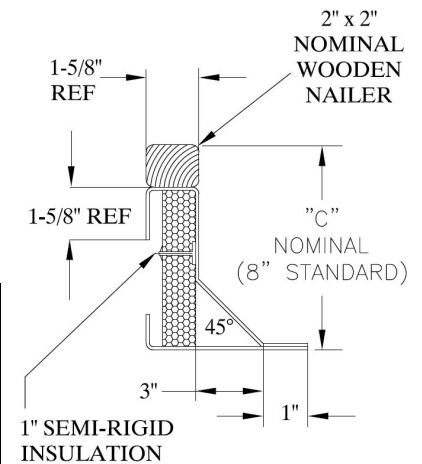

### STANDARD CONSTRUCTION

Fabricated using aluminum alloy 3003-H-14  
3lb. Density 1" thick insulation  
2"x2" nominal wood nailer  
Mill finish is standard  
"C" dimension=8in. (standard)  
Damper tray optional

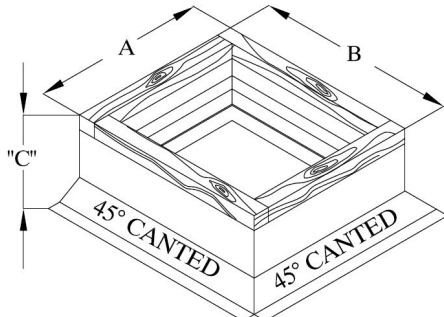

Side	Minimum Size	Maximum Size
A	6"	Contact factory
B	6"	
C	6"	

### LA-SF ALUMINUM CANTED CURB

