

HOW TO CARE FOR YOUR SR30_{THX} SURROUNDS

Cabinet

Your speaker system has been finished with either a black or white paint. Multiple layers of paint, along with hand sanding between each coat, provide a durable and smooth finish.

- ▶ To clean, use a soft terry cloth towel slightly dampened with water or a mild detergent. The towel should be just damp enough to wipe the surface clean without leaving a trail of moisture.

- ▶ Do not use abrasive cleaners or any cleaner containing chemicals harsher than those found in glass cleaner.

Grille Cloth

- ▶ You can remove the top and front grilles from the speaker system and gently vacuum to remove dust.

LISTENING LEVELS AND POWER HANDLING

The power recommendation for the system assumes you will operate the amplifier in a way that will not produce distortion. All speakers can be damaged by a modest amplifier if it is producing distortion. If you hear a gritty noise or other signs

of strain, turn down the volume. Prolonged or repeated operation of your speakers with a distorted signal can cause damage that is not covered by the warranty.

LIMITED WARRANTY

For five years from the date of purchase, Snell Acoustics will repair for the original owner any defect in materials or workmanship that occurs in normal use of the SR30_{THX} 's without charge for parts and labor.

Your responsibilities are to use the product according to the instructions supplied, to provide safe and secure transportation to an authorized Snell Acoustics service representative, and to present proof of purchase from an authorized Snell dealer in the form of your sales slip when requesting service.

Excluded from this warranty is damage that results from abuse, misuse, accidents, shipping, repairs, or modifications by anyone other than an authorized Snell Acoustics service representative. This warranty is void if the serial number has been removed or defaced.

This warranty gives you specific legal rights, and you may also have other rights that vary from state to state.

If Service Seems Necessary

Contact the dealer from whom you purchased the speaker systems. If that is not possible, call us at 978-373-6114, or write to:

Snell Acoustics
143 Essex Street
Haverhill, MA 01832

We will promptly advise you of what action to take. If it is necessary to return your speaker system to the factory, please ship it prepaid. After it has been repaired, we will return it freight prepaid in the U.S. or Canada.

Manufactured under license from Lucasfilm Ltd. U.S. patent number 5,109,416. Foreign patents pending. Lucasfilm, THX and Ultra 2 are trademarks or registered trademarks of Lucasfilm, Ltd.

©2002 Snell Acoustics. All Rights Reserved.
Specifications are subject to change without notice.
Part #542-1006-1

Snell

143 Essex Street
Haverhill, MA 01832
phone: 978-373-6114
fax: 978-373-6172
email: info@snellacoustics.com
www.snellacoustics.com

LUCASFILM
THX
U L T R A 2

Surround Speaker System
Owner's Manual

SR30_{THX}

Snell

SPECIFICATIONS

Frequency Range (-6dB)	60–20,000Hz
Frequency Response (±3dB)	70–20,000Hz
Recommended Amplifier Power	20–150 watt
Nominal Impedance	4 ohms
Sensitivity (2.83v at 1m)	88dB, speaker in half-space, wall-mounted
High-Frequency Drivers	Three 1-inch (25mm) black-anodized aluminum-dome tweeters with neodymium magnet structure
Midrange Frequency Drivers	Dual 3.5" (89mm) extended-range units with copolymer cones
Bass Unit	6.5" (165mm) omnidirectional dual-voice coil unit with a stamped steel basket and treated paper cone
Crossover Frequency	400Hz, 3kHz
Cabinet Construction	High-density fiberboard
Grilles	Cloth-covered masonite frames mounted with Velcro® fasteners
Flush-Mounting Bracket	Positive-click locking mounting bracket for wall
Included Hardware	Eight (8) 3" #10 machine screws with toggle wings Eight (8) 2" #8 particleboard screws Eight (8) felt bumpers Two (2) mounting templates
Dimensions (HxWxD)	16.0 x 16.25 x 8.25" (406.4 x 412.8 x 209.6mm)
Weight/each	18 lbs (8.3kg)
Finish	Hand-sanded, hand-painted Black or White paint
Options	Surround mode controlled by a 12V DC relay, additional charges apply

INTRODUCTION

A good surround speaker adds realism to today's multichannel audio systems by expanding the stereo spread beyond the front speakers or by creating an all-enveloping sound field, but not necessarily both. Snell's new SR30_{THX} surround speaker surpasses previous surround speakers by offering the easily switchable choice between a diffuse field or a direct field response.

For Use with All Home Theater Formats

The SR30_{THX}'s meet the demanding sonic requirements of digital 5.1/7.1 channel formats as well as the demanding specifications of THX Ultra 2.

- The SR30_{THX} allows you to switch, using multiple drivers and a sophisticated acoustical matrixing technique, between an

outward-firing direct sound field balanced to precisely match our Snell front-channel speakers or a "fore and aft" firing diffuse sound field.

- The multiple drive units of a single enclosure used to create these effects can be split into forward and backward sections for convenient use with 7.1 channel systems, with all four side and rear channels reproduced by a single pair of SR30_{THX}'s.
- A larger-than-normal woofer assures that the SR30_{THX} is a full-range system to take advantage of the wide-range surround tracks available from discrete multichannel recording formats.
- An elegant, tapered enclosure packages all of these features in a pleasing on-wall cabinet.

CONNECTING THE SR30_{THX} SURROUNDS (CONT.)

For Seven-Channel Applications

Select the diffuse surround mode with the toggle switch.

Remove the gold jumper bars from the inputs.

Connect the two sets of speaker cable to the appropriate 7.1 channel inputs.

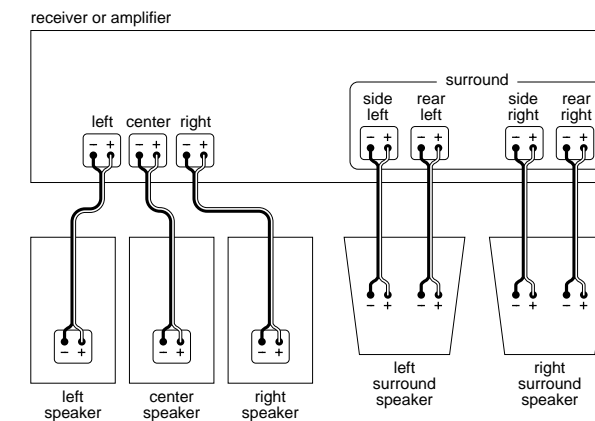

Optional Relay Control

If you have purchased an SR30_{THX} with relay control (or an upgrade kit), the speaker's default setting is "DIFFUSE-THX ULTRA2 MODE" = 0 Volts

When a 12VDC control signal is applied, surround mode is switched to "DIRECT MODE". Two unpolarized cables with .110" terminals are provided at the rear for this purpose

Surround Processor Settings

When using a subwoofer:

Select the SMALL or NORMAL surround setting on your receiver or processor. This routes all bass information (typically below 100Hz) from the surrounds to your subwoofer.

When not using a subwoofer:

Select the LARGE surround setting on your receiver or processor. This routes all bass information to your surrounds.

Match the Sound Levels of Each Speaker

Your home theater system most likely includes a test signal that simplifies level matching. Refer to the instructions provided with your surround sound electronics.

Connecting with Bare Wire

Insert bare wire into holes and tighten.

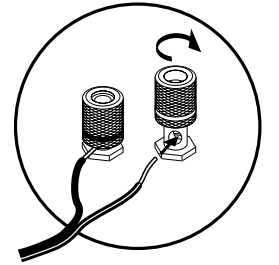

Connecting with Banana Plugs, Spade Lugs, or Pins

The binding posts accept standard banana plugs and pins, and can accommodate spade lugs up to 5/16 inch.

Warning! To prevent electrical shock, always switch off the amplifier or receiver when making connections to the speaker system.

SR30_{THX} Operation and Use

The diffuse mode is most appropriate when the inability to localize sound is desirable. This should be perceived as a "wall-of-sound." Music with side channels encoded with hall effects will produce a feeling of envelopment. Surround encoded baseball games will be heard as if the stadium were all around, with no clear source of off-the-field, realism-enhancing effects.

Both music and movies will have instances when either "direct" or "diffuse" surround sound will suit. Music recordings with musicians in the side channels will most likely sound best in "direct" (refer to Fig. 1B). However, if the side channels are used to record the performance environment or audience sounds, the "diffuse" mode may be best.

Similarly, with movie soundtracks, some producers will use side channels to pan discrete sources off-screen (e.g., jet fly-bys, etc.). This material will be well served with the "direct" mode. Other movies will use the side channels to transport you to a remote environment with street noises, crowd noises, etc. These may be best reproduced in "diffuse" mode.

The surround mode switch is conveniently located under the right side of the grille to allow easy access. Swing the right side of the grille outward to reveal the switch. It is located midway up the cabinet within the matrix driver recess. Refer to the switch diagram (on the top-right panel of the speaker) and the figures to determine the appropriate setting. SR30_{THX} provides a unique experience with its ability to produce multiple polar patterns. You should take some time and experiment to best adapt this surround speaker to your listening habits.

WALL MOUNTING YOUR SR30_{THX} SURROUNDS

The SR30_{THX} is mounted via a unique slide-on mounting plate. The plate is first screwed to the wall at the appropriate position and then the speaker slides down, firmly locking in place. The plate must be mounted with the long groove toward the wall and the notch at the bottom.

The enclosed mounting template will guide you in locating the mounting screws. In addition, it will ensure the minimum clearance to the ceiling as required by the mounting bracket.

Please Note

Installation of surround speakers requires a thorough understanding of construction tools and procedures. We recommend you consult a knowledgeable installer if you are unsure of the physical properties behind your walls.

Mounting on Drywall, Paneling, or Other Hollow Surfaces

Use the supplied 3-inch #10 machine screws and toggle wings. The toggle wings require a 9/16-inch (13mm) hole. Do not attempt to mount the SR30_{THX}'s to drywall with any of the commonly available plastic anchors (push-in inserts).

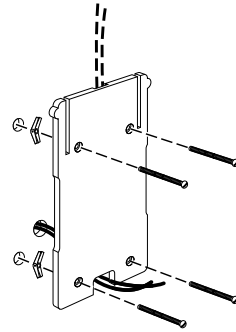

Mounting on Wood and Other Solid Surfaces

Use the supplied 2-inch #8 particleboard screws. For best results, predrill the hole with a 1/8-inch drillbit.

Mounting on Masonry, Adobe, and Similar Surfaces

Consult a knowledgeable installer about proper hardware. You will obtain best results with #8 screws.

Mounting the Bracket When Using the Machine Screws and Toggle Wings

1. Drill two 9/16-inch (13mm) holes using the included template. If running wires behind the wall, make a hole for them as well.
2. Insert the machine screws through the bracket and thread onto the toggle wings before penetrating the wall.
3. Level the bracket and tighten screws.
4. Guide the wires through the back.
5. Place the SR30_{THX} on the bracket and slide down until you hear a locking "click."
6. Connect the wires.

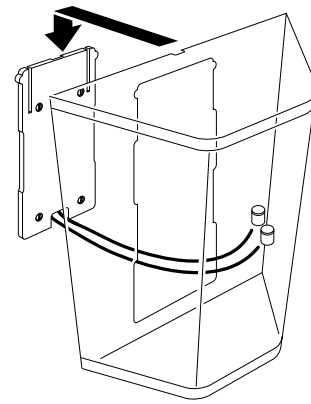

CONNECTING THE SR30_{THX} SURROUNDS

For Five-Channel Applications (including THX systems)

Select either surround mode with the toggle switch. When used with a THX receiver/processor, please select the "DIFFUSE-THX ULTRA2 MODE".

Connect a set of speaker cables to either set of inputs. You may want to consider running a second set of speaker cables for each surround if you think you may upgrade to a 7.1 channel system in the near future.

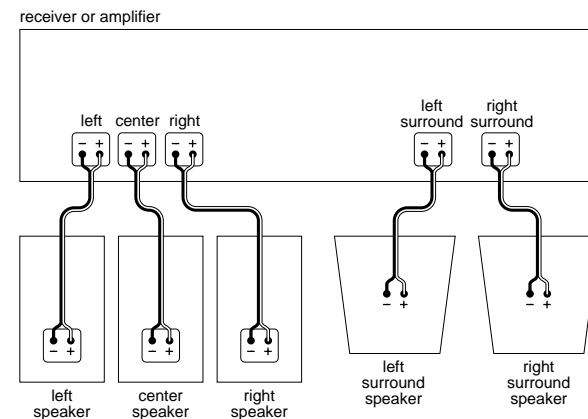

SR30_{THX} FEATURES

- 1 Hand-tuned crossover
- 2 Recessed side-firing tweeter for best diffuse sound
- 3 Front-firing tweeter for best direct sound mode
- 4 6.5" (165mm) dual-voice coil bass unit
- 5 Toggle switch for convenient surround mode selection
- 6 Matrixed midranges for switchable direct/diffuse sound
- 7 Input terminals with removable jumpers for easy 7.1 upgrades
- 8 Truss bottom panel

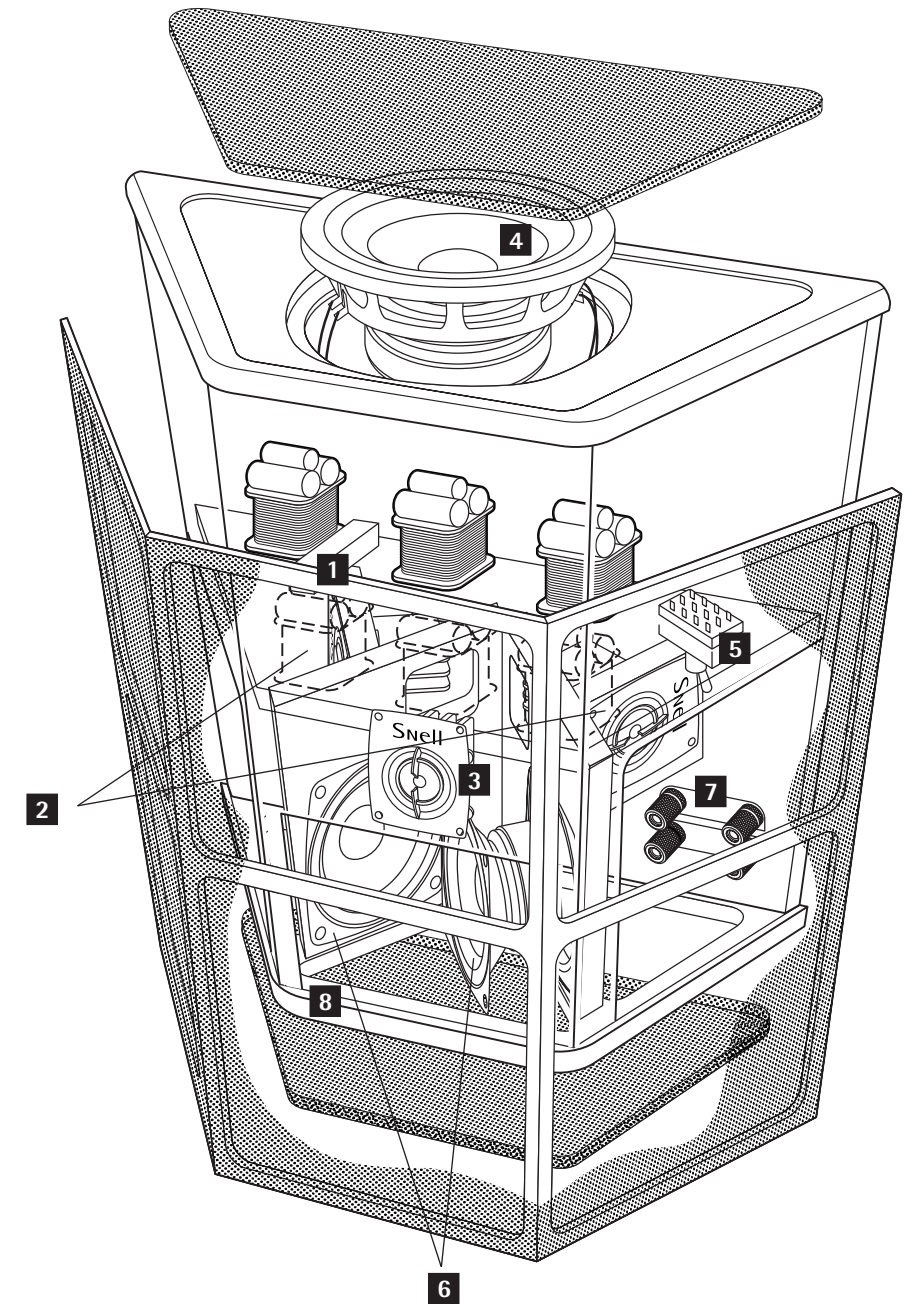

FEATURES OF THE SR30_{THX} SURROUND

Unique Cabinet Design

A sealed enclosure above and a unique matrix array below project sound in three distinct polar patterns. The truss panel bottom reduces the detrimental effects of standing waves within the cabinet.

Speaker Elements

Three 1-inch aluminum-dome tweeters cover frequencies above 3kHz. Two 3.5-inch (89mm) extended-range drivers are responsible for frequencies between 400Hz and 3kHz. One omnidirectional 6.5-inch (135mm) dual-voice coil bass unit handles all frequencies from 60Hz to 400Hz.

Family of Sound

The SR30_{THX} 's are tuned with a flat, optimized power response, to match the spectral balance of Snell front speakers. The use of common Snell driver units and careful optimization provide a direct mode frequency response that is an excellent match with Snell front speakers.

HOW TO PLACE YOUR SR30_{THX} SURROUNDS

Theory of Operation

Today, surround speakers are called upon to do one of two disparate tasks. For some movies, you may want a surround to create an all-enveloping diffuse field. Sound should arrive at your two ears by bouncing numerous times off of all your listening room walls.

Conversely, with multichannel music, you may want the musical stage to widen beyond the front speakers by having a spread of five near-identical speakers over a semicircular arc around you. You may want movie effects to pan solidly off the screen and to the sides. This demands the side speakers to be well matched to your front speakers both in frequency balance and in their more focused directional characteristics.

Until now, surround sound speaker designers had to choose between satisfying one requirement or the other, or perhaps choosing a middle-ground compromise. The SR30_{THX} provides a choice of surround sound modes, allowing performance to be tailored to program material.

Hand-Tuned Crossover

The filter network is optimized to provide a smooth and flat power response in diffuse mode. Each crossover is tuned by our technicians to 0.5dB of the Master Reference, assuring predictable performance in your home. Furthermore, a sophisticated switching network enables the SR30_{THX} to perform in any application.

Mounts to Walls

Our unique locking bracket keeps the SR30_{THX} securely mounted to walls. One person can install the SR30_{THX} simply, securely, and easily.

Connectors

Five-way gold-plated binding posts allow quick connection to speaker cables and connections. Furthermore, removable jumpers accommodate the use of SR30_{THX} in 7.1 channel applications, now or for future system upgrades.

Placement

Although often mistakenly referred to as rear speakers, your surround speakers should ideally be placed to the left and right of the listening area. In the diffuse mode, internal switching converts the radiation pattern of the super surround to a fore and aft radiating dipole (see Figure 1A). This null will reduce the amount of direct sound at the listener's ears. The radiation along the length of the room will maximize the reflected sound heard. For this reason, the speakers should be placed so that the listener is within the null of the speaker. Efforts were made to widen the angle of the response null so that the "phasiness" of regular dipoles and their critical positioning requirements were reduced.

Proper room placement is perhaps the most important factor contributing to home theater sound quality. Take a few minutes to place your speaker system correctly to ensure that it sounds its best.

HOW TO PLACE YOUR SR30_{THX} SURROUNDS (CONT.)

Placement (cont.)

Listening Room Placement

Follow these guidelines for proper placement. (Refer to Ideal SR30_{THX} Placement diagram.)

Height

Place the surrounds at least 5 feet (1.5m) from the floor, yet 12 inches (30cm) from the ceiling. Higher is better.

Placement

On the side walls, center surrounds to the listening area.

Boundaries

Keep the surrounds at least 12 inches (30cm) away from an adjacent wall or a large obstacle.

7.1 Mode Placement

This option provides the greatest flexibility for speaker placement. Please use the 7.1 Mode Placement diagram and 7.1 radiation patterns (Fig. 1C), as guidelines for placing the SR30_{THX} 's. Keep in mind as you move the speaker forward or backward from the seating area, you are actually aiming a section (or half) of the speaker at the listeners and creating a more direct sound field. The other section of the speaker will be aimed at the rear or front wall, thus creating a diffuse sound field for that channel.

Coverage Area

In larger spaces, we recommend using one surround speaker system for every three rows of seats (approximately 10 inches between surround speakers).

Ideal SR30_{THX} Placement for Direct/Diffuse Response

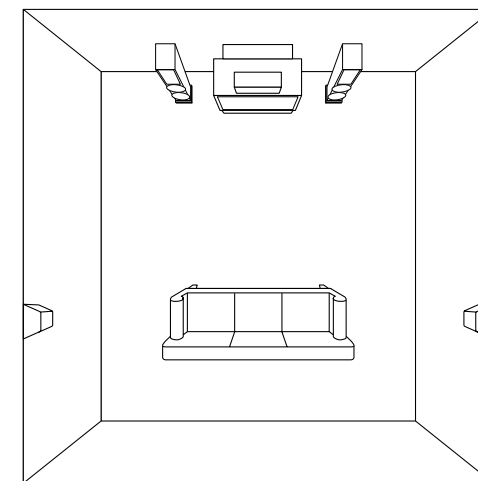

Fig. 1A
Switch set to Diffuse-THX Ultra2 Response

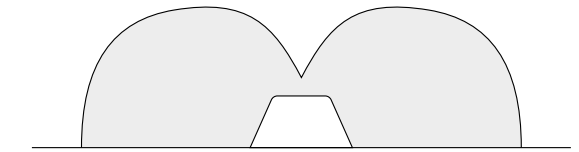

Fig. 1B
Switch set to Direct Response

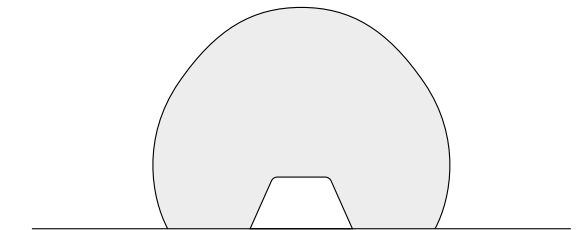
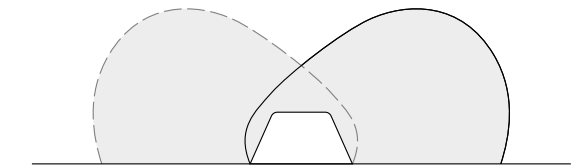

Fig. 1C
Switch set to 7.1 Mode (Jumpers Removed)



7.1 Mode Placement

