

# What is the Best Generator Type for a 5MW Wind Turbine?

A Comparison of Doubly Fed and  
Permanent Magnet Generators for Wind Turbines

Presented at AWEA Offshore Windpower Conference  
Baltimore, Maryland, USA  
October 12, 2011

Author: Rain Byars  
Nextwind, Inc.  
(+1) 904-712-0030

## **Abstract**

The choice of generator and converter type are critical to the cost of energy of a wind turbine. However the effects of these choices on the system design and park operation and income are too often overlooked. Annual energy output is a primary consideration. In addition system reliability is cost critical, becoming more so with larger machines or offshore installation.

This paper will examine the two most popular generator and converter options for modern wind turbines, doubly fed and permanent magnet, in terms of driving design criteria. The paper will compare annual energy output, weight, cost of service, reliability, fulfillment of grid requirements, and up front cost of the two options, all of which affect the cost of energy.

The paper will explain the calculation of the annual energy production (AEP) for each variant. The magnitude of the effect of generator and converter type on AEP have been shown to vary depending on wind class as well as rotor size, so these factors will be considered and presented as well.

The cost of service depends both on regular maintenance and on repair and replacement costs. Reliability is difficult to quantify, but some comparison is possible based on converter and generator internal reliability as well as the impact of the converter and generator on other components in the wind turbine.

Further influences to be considered separately include voltage of generator and converter as well as speed of generator.

## **Executive Summary**

The author performed a concept study of power system architectures for a 5MW offshore wind turbine designed for manufacture and installation in China. At the time of the study, the wind turbine manufacturer had already specified rotor size, drivetrain configuration, and gearbox ratio. Factors including generator type, converter topology, system voltage, and electrical component placement were assessed regarding up front cost, lifetime cost and reliability, tower top weight, and annual energy production.

This paper focuses on the results of the generator type assessment, specifically on the two most popular and available generator types for wind turbines: Doubly Fed (DFIG) and Permanent Magnet (PMG). Other factors including system voltage and drivetrain configuration will be addressed in a future paper.

For a multi-megawatt offshore wind turbine, a permanent magnet generator is a clear choice for optimizing all factors affecting the cost of energy of the installed turbine.

## **Introduction**

Most multi-megawatt wind turbines manufactured today are equipped with a PMG or a DFIG. Which is the best generator type in terms of annual energy output, weight, cost of service, reliability, fulfillment of grid requirements, and up front cost - all of which affect the cost of energy?

## **Method**

### **Nominal Turbine**

All calculations are based on a 5MW nominal wind turbine. The configuration is an upwind, three bladed turbine with active pitch and variable speed operation. The turbine has a 148 meter diameter rotor with standard LM blades, and a three stage gearbox with a 97:1 gear ratio. The hub height is 100 meters.

### **Nominal Site**

The site conditions used for the comparison are based on an IEC class II site. The site is near shore, with 8.5 mps annual average wind speed at hub height. Sea level density and 18% turbulence are assumed.

### **Electrical Components Input Data**

In the course of the study, the author conducted meetings with several leading suppliers of wind turbine generators and converters. ABB, The Switch, and Ingeteam have each provided technical data for the calculation of annual energy production, as well as weight and reliability input. These companies each have extensive experience with development, manufacture, and service of one or both of the generator types compared for on and off shore wind turbine applications.

Information from direct discussion and from documents provided by these suppliers were included in the comparison of generator types.

Further, figures for upfront costs, service costs, and reliability have been estimated by the author based on past and ongoing experience reviewing operational data of wind turbines with different power system configurations.

### **AEP Calculation**

In order to approach an accurate calculation of AEP, it is important to realize that a wind turbine spends the majority of its operating hours at partial power. Each component of the power train has an efficiency profile, with actual efficiency depending on wind speed, rpm, or percentage of nominal power.

The blade, the gearbox, the generator, and the converter have different efficiencies based on these factors. Other losses such as cable heat dissipation are directly proportional to the power level, while consumers, such as cooling fans and yaw motors, can be assumed to be a constant load.

For the purposes of this study, a spreadsheet was created which could calculate the aggregate efficiency of the turbine for each wind speed. The output of this calculation was then overlaid with a wind speed distribution for a given average wind speed to determine the AEP.

To compare the PMG to the DFIG, the wind speed distribution, blade aerodynamic performance, gearbox efficiency curve, and other losses were kept constant while varying the generator and converter efficiency curves. The aggregate efficiency curves can be seen in the results section.

## Generator Types

### DFIG

The Doubly Fed Induction Generator (DFIG) stator is directly connected to the grid, while the rotor current, comprising approximately 30% of the total output, passes through slip rings and is controlled by a 4 quadrant converter.

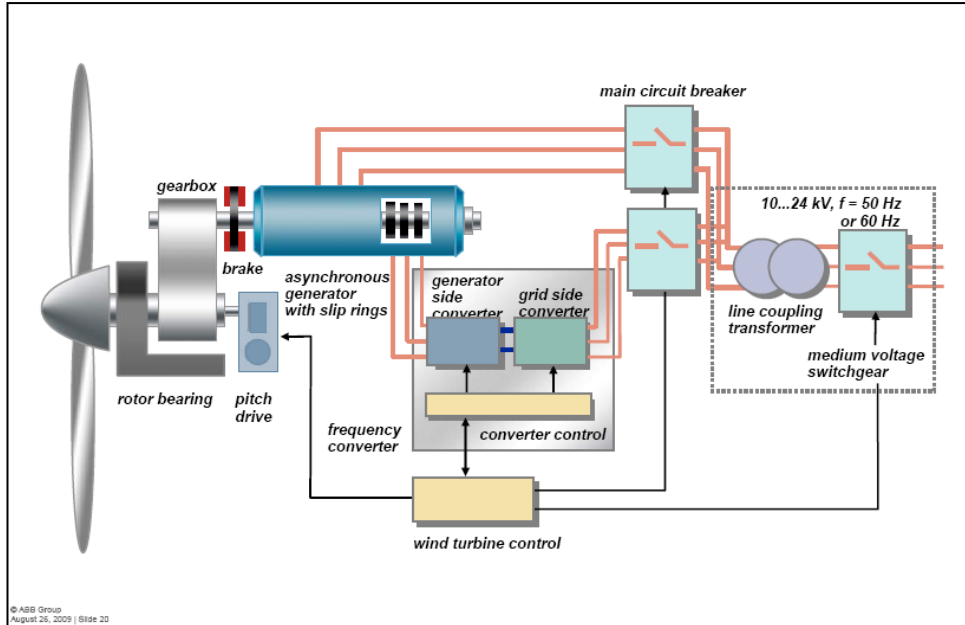

Figure 1: Layout of DFIG power system, courtesy ABB



Figure 2: DFIG, courtesy ABB

## PMG

The Permanent Magnet Generator (PMG) has a rotor equipped with permanent magnets. The stator is connected to a full 4 quadrant converter which is used to control torque on the generator.

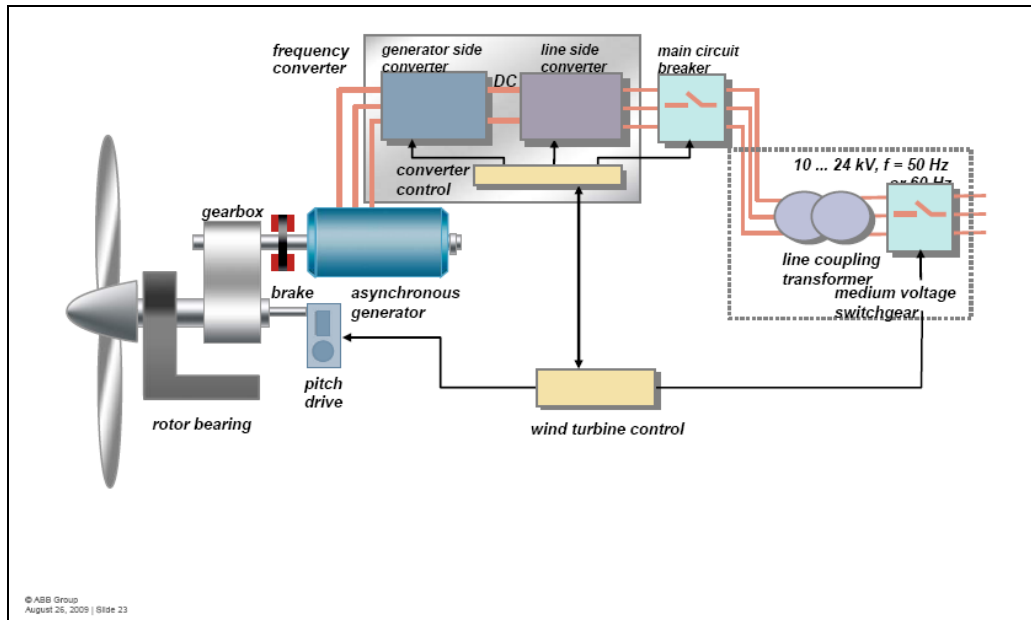

Figure 3: Layout of Permanent Magnet Generator based power system, courtesy ABB



Figure 4: Permanent Magnet Generator, courtesy The Switch



Figure 5: Four Quadrant Converter, courtesy The Switch

## Considerations

The Cost of Energy (COE) of the wind turbine is directly dependent on the power output measured in annual energy production (AEP) and the lifetime cost.

Lifetime cost consists of a combination of upfront cost and service cost, where service cost depends on service frequency as well as time and equipment required for each service procedure.

The reliability of each component is an important driving factor for the lifetime cost. Accurate MTBF calculation of a wind turbine or subsystem is challenging due to a dearth of impartial measurements. Direct experience with the technologies and a sampling of operator feedback can give a trend which is useful for comparison of technologies.

AEP is not directly a result of peak efficiency or peak power, but is dependent on the time spent at each wind speed together with the corresponding partial power capture and partial power generation and conversion efficiency.

Grid compatibility and support is a factor regarding successful interconnection application. Failure of the turbine technology to meet minimum stringent interconnection standards can result in excessive additional up front cost to bring the wind park in to compliance.

The size and weight of the generator and converter equipment is a factor as well. Although size and weight may not seem to directly affect cost, minimizing tower top weight is a goal for wind turbine designers for several reasons. Weight of components affect inbound transportation costs of the components and outbound transportation costs of the assembled turbine. Crane size for assembly, on site erection, and component replacement over the life of the wind farm can be a factor as well.

Weight at the tower top affects the loads, and therefore the amount of steel needed in the support structure and tower. Finally, the overall dimensions and footprint of the generator and converter affect the dimensions of the support structure, again affecting tower top weight.

## Results

### AEP Results

The PMG has the highest annual power output, with a 2.2% increase in AEP over the DFIG for an IEC class II site. The PMG has a higher efficiency curve, with much higher efficiency at partial power, where the highest number of operating hours are spent.

The DFIG has a higher efficiency at rated speed. Additionally, the converter losses are only applied to 30% of the power output of the generator. This results in lower overall losses *at full power*.

A significant difference in power output becomes apparent when the operating speed range is taken in to account. The PMG can begin producing power at very low rpms, but the DFIG is limited to the synchronous speed less 30% - in the case of the 6 pole DFIG on a 50Hz grid, this is 700 rpm. This affects the cut in of the wind turbine and contributes to a higher overall AEP from the PMG.

The AEP results do not consider availability, as this was considered separately.

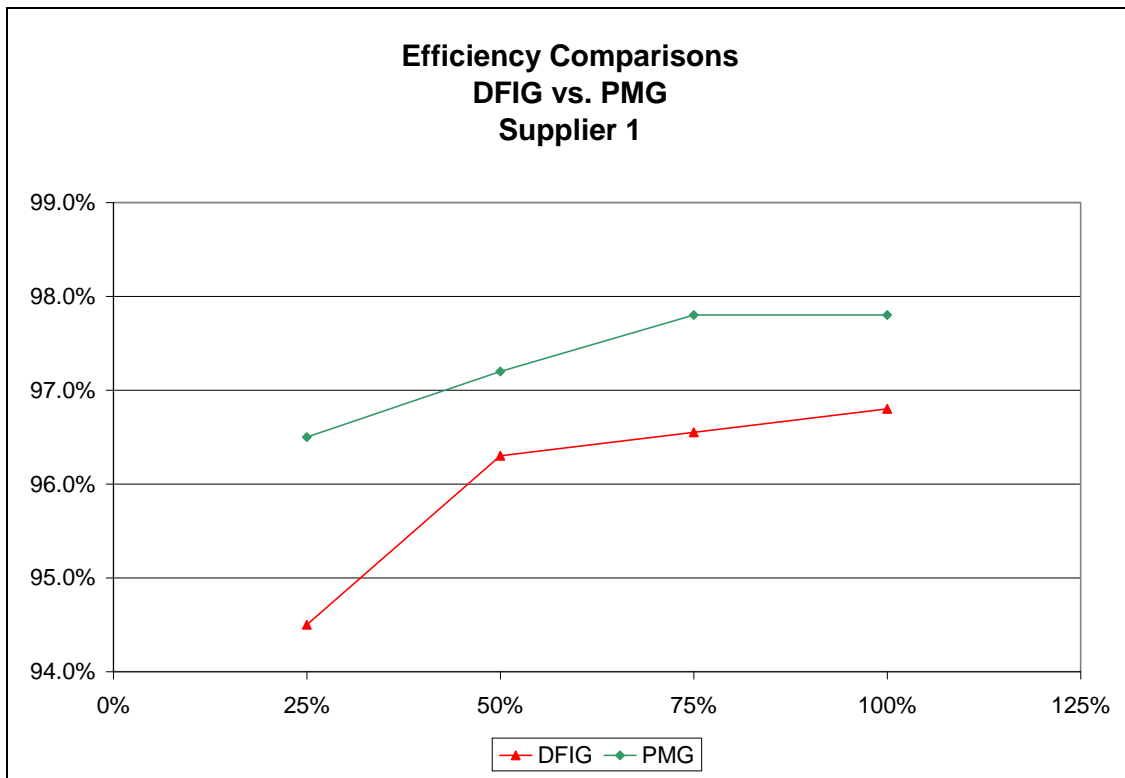

Figure 6: DFIG vs. PMG Efficiency Supplier 1

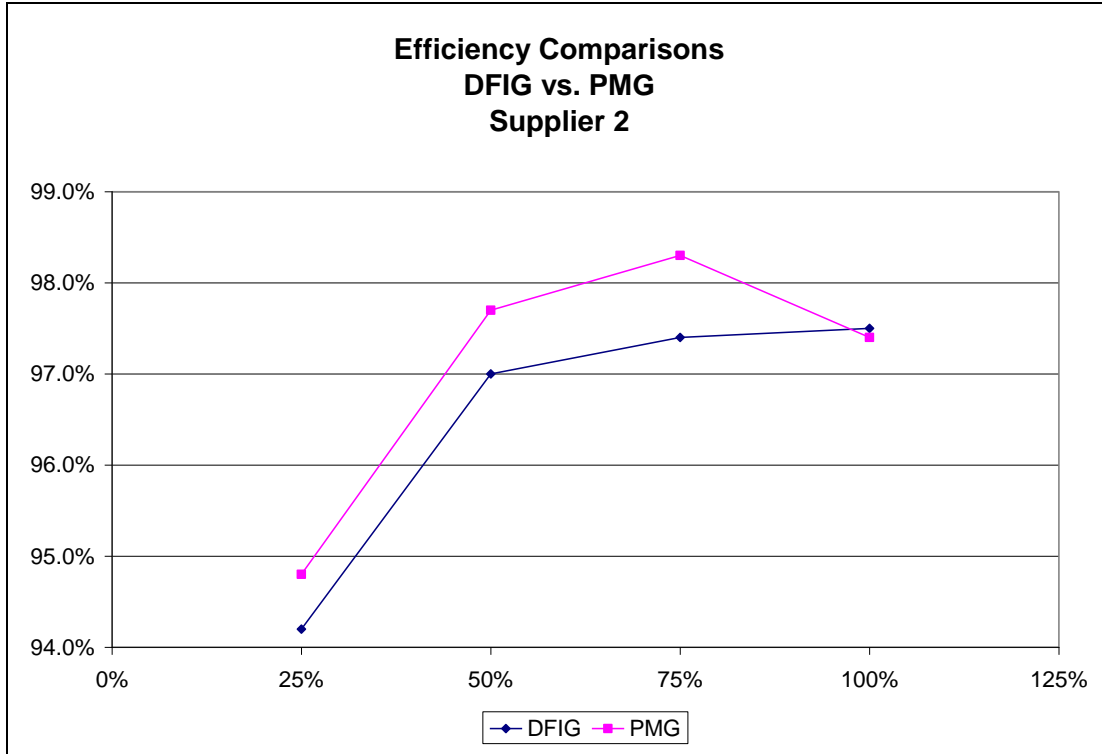

Figure 7: DFIG vs. PMG Efficiency Supplier 2

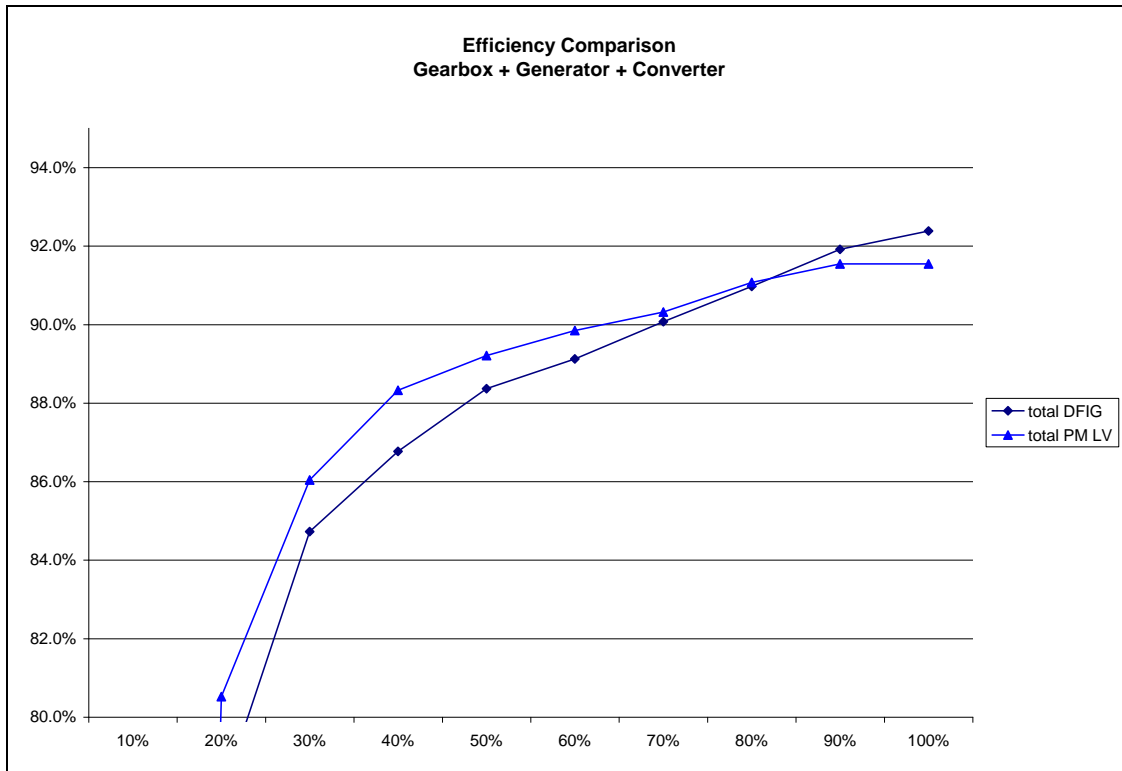

Figure 8: DFIG vs. PMG Aggregate Efficiency Curves



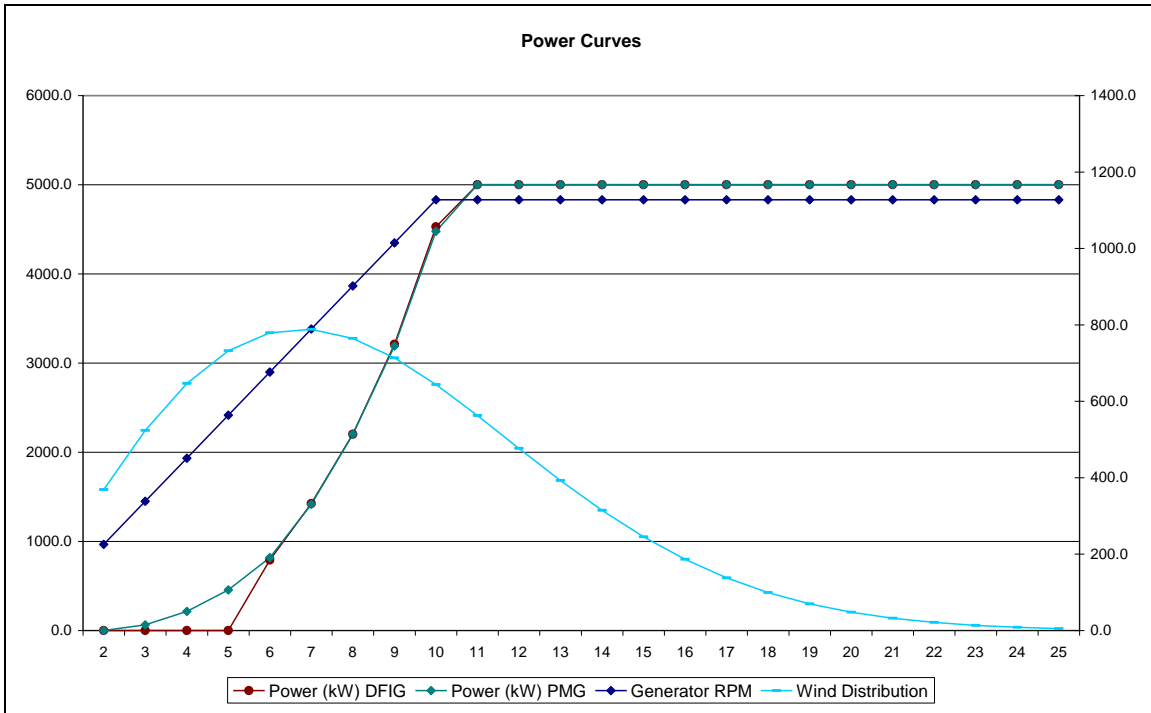

Figure 9: DFIG vs. PMG Power Curves with Wind Distribution

### Effect of Wind Class

The difference in AEP becomes larger at lower average wind speeds and becomes less significant at higher average wind speeds. This is due to better performance of the PMG at partial power.

Comparison of Wind Classes				
<b>Constants</b>				
clean blade, steady power curve				
148m rotor				
97:1 Gearbox Ratio				
IEC Class	<b>class I</b>	<b>class II</b>	<b>class III</b>	<b>class IV</b>
Avg. Windspeed	10mps	8.5 mps	7.5 mps	6 mps
DFIG	baseline	baseline	baseline	baseline
PMG increase in AEP	1.39%	2.20%	3.24%	6.91%

### Effect of Rotor Area

The difference in performance between the DFIG and the PMG is also dependent on the rotor size. The difference is greater with a larger rotor. This is due to the lower operating speed of the larger rotor.

Comparison of Rotor Sizes		
<b>Constants</b>		
IEC Class II		
8.5 mps		
97:1 Gearbox Ratio		
Rotor Diameter	<b>126</b>	<b>148</b>
DFIG	baseline	baseline
PMG increase in AEP	1.85%	2.20%

### Upfront Costs

The DFIG has a lower upfront cost. Because of the higher cost of magnets, a DFIG generator is usually less expensive. Additionally, when a partial converter is used, the converter can use smaller (or fewer) modules and is therefore less expensive.

The partial converter is also lighter and more compact than the full converter, resulting in easier system integration of the cabinets.

The PMG has a lower weight than the DFIG for the same nominal power output. Due to having no slip rings and better heat characteristics, the PMG can be made shorter and lighter than the DFIG. Due to the reduced generator length, the generator frame and nacelle can be shortened compared to DFIG configuration.

It can be estimated that the DFIG (generator and converter) will represent a 30% savings in up front costs compared to the PMG (generator and converter).

## **Grid Requirements**

The PMG is also a good choice for grid code compliance. Due to the full converter, all requirements for harmonics, power factor control, and grid fault ride through can be met easily.

There is extra cost related to meeting new grid codes with the DFIG. With fault ride through and power factor capability, the DFIG converter becomes similar in size and cost to the full converter.

The DFIG presents a difficulty in export due to modification for different frequencies. The generator design (number of poles, winding configuration) must be changed for 50Hz or 60Hz applications. The gearbox design must also usually be changed.

## **Reliability**

The PMG has high reliability and low maintenance cost due to better heat performance, no slip rings, and no encoder.

The DFIG creates a negative impact on reliability and increased maintenance cost due to increased gearbox loads from grid transients. Shifts in grid voltage and frequency result in high cycle tooth loads on the gearbox resulting in micropitting. Additionally, slip rings require inspection at 6 month intervals and frequent replacement. In low temperature or marine environments, the maintenance interval may be even shorter.

The generator speed encoder required for the partial converter concept is vulnerable to lightning, contamination, and bearing failure due to vibration and shaft bending.

DFIG generators tend to have high induced shaft currents. This can be mitigated with insulated bearings and grounding brushes, however these systems are expensive and the extra components bring the MTBF down.

The MTBF for components of the PMG and converter is estimated at 8000 hours.

The MTBF for components of the DFIG and converter is estimated at 1500 hours.

## **Service Cost**

The service costs for most failures will be limited to personnel hours and lost production. The service costs for failures of main components will include component costs and crane time in addition to personnel hours and lost production.

It is estimated that the service costs per year for the DFIG and converter with the additional service costs for the gearbox, will be 20% to 30% higher than the service costs for the PMG.

## **Cost of Energy Results**

Cost of Energy is calculated from initial costs, operating costs, and annual energy production, and the assumptions for the COE calculation will vary widely based on site conditions and service strategy. It is outside the scope of this paper to attempt to calculate COE for this turbine configuration. However, it is possible to identify a trend based on the relative contribution of the upfront costs of the generator and converter to the overall upfront costs of the wind turbine, and the contribution of the service costs of the generator and converter to the overall operating costs of a wind park, and the difference in AEP for the two configurations.

It is clear that the improvements in AEP and cost of service for the PMG outweigh the higher up front cost, and that a wind turbine with a PMG will achieve a lower cost of energy compared to a wind turbine equipped with a DFIG.

### Side by Side Comparison

	<b>DFIG</b>	<b>PMG</b>
Nominal Power (kW)	5400	5500
Frame Size (mm)	800	710
Length (m)	3.4m L	2.7m L
Weight (T)	16.5T	14T
Upfront Cost Gen (\$US)	\$230k	\$255k
Upfront Cost Conv (\$US)	\$180k	\$300k
Service Cost	high	low
Grid Compatibility	poor	excellent
AEP	100.0%	102.2%

### Next Steps

#### Voltage level

A comparison of low voltage (690V) vs. medium voltage (3 to 12 kV) system can be made based on converter efficiency curves. The medium voltage technology offers design advantages (size and mass, cable routing), but presents service challenges and potentially higher service costs.

#### Drivetrain

A calculation was not performed to compare the mid speed and high speed variants due to lack of comparable gearbox efficiency curves and generator efficiency curves to perform the calculation. However it is generally accepted that a medium speed drivetrain will result in an efficiency gain on the order of 1%.