

Attached Garage Checklist

Site Plan

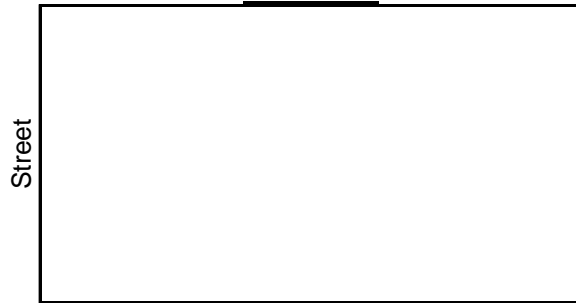

On Site Plan:

- Show size and location of proposed attached garage
- Show distance to side property line
- Show distance to rear property line
- Show location on dwelling
- Show lot dimensions and shape of lot
- Show all existing buildings
- Show direction of North
- Show all windows and doors on existing structures

Wall System

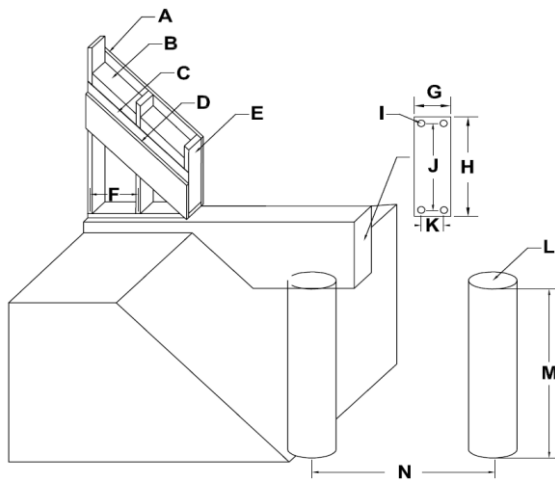

Roof System

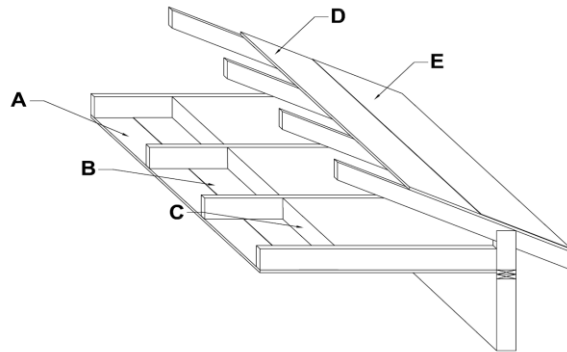

Wall System	Roof System
A - Outside Sheathing:	A - Interior Finish:
B - Insulation Value:	B - Type of Vapour Barrier:
C - Type of Vapour Barrier:	C - Insulation Value:
D - Interior Finish:	D - Exterior Sheathing:
E - Stud Size	E - Type of Roofing:
F - Stud Spacing	Roof Overhang
G - Grade Beam Thickness:	Garage Door
H - Grade Beam Height:	Door Span _____
I - Size of Rebar:	Lintel Size _____
J - Rebar Spacing:	Ply _____
K - Rebar Spacing:	
L - Pile Diameter:	
M - Pile Depth:	
N - Pile Span:	
Wall Height:	
Void Form Type and Size:	

I hereby acknowledge that I have read this application and state that the above is correct and agree to comply with all Municipal By-Laws and/or Provincial Laws regulating building.
 It being expressly understood that the issuing of a permit does not relieve the applicant from complying with all By-Laws, though not called for in the specifications, or shown on plans and/or application submitted.

Applicant (Print Please) _____ Date _____

Applicant Signature _____ Date _____

Application Received By _____ Date Received _____