

Aluminium / timber door handle fixing options

Code: A3

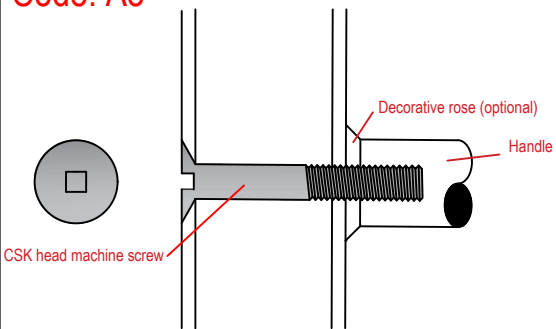

A3 - CSK head machine screw for bolt through fixing single handle.
Thread = M12
Hole prep = 13mm dia
PLEASE SPECIFY DOOR THICKNESS AT TIME OF ORDER

Code: A1

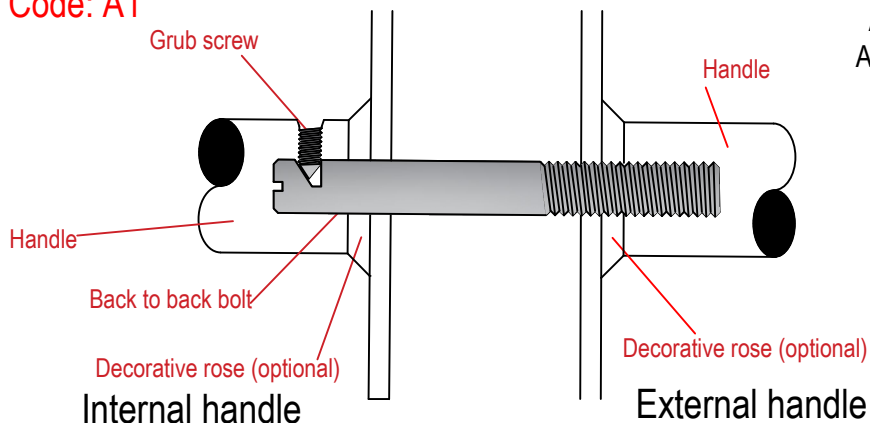

A1 - Back to back fixing for aluminium doors 30mm to 65mm thick.
A1.125 Back to back fixing for aluminium doors 66mm to 90mm thick.
Thread = M12 (M6 grub screw)
Hole Prep = 13mm dia.

IMPORTANT FITTING INFORMATION

To ensure correct fitment of back to back handles, the grub screw on the internal handle must hit the top of the slope on the fixing bolt. **As the grub screw is tightened the handles will pull together towards each other and be tight against the door. The handles will be held under compression.** If the handles do not pull together the installation is incorrect.

As a guide the bolt will protrude 15mm from the face of the door (or the face of the rose if used).

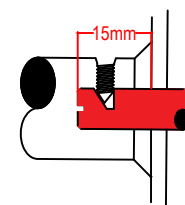

Code: A4

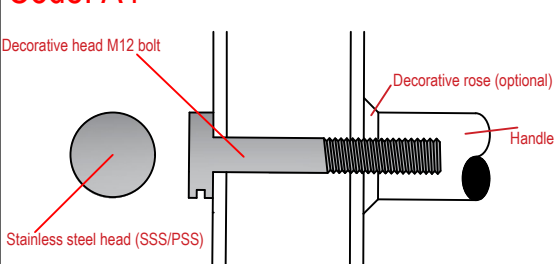

A4 - Stainless steel head decorative bolt for single side fixed handle.
Thread M12
Hole prep - 13mm dia.
PLEASE SPECIFY DOOR THICKNESS AT TIME OF ORDER

Code: A7

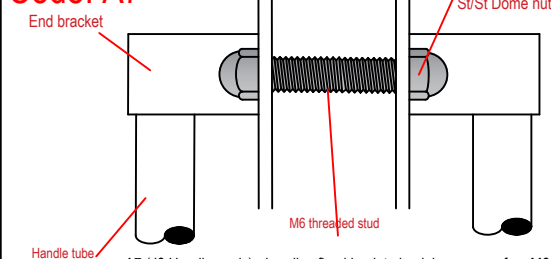

A7 (J6 Handles only) - handles fixed back to back by means of an M6 threaded stud secured with stainless steel dome nuts
Thread M6
Hole prep = 8mm dia
PLEASE SPECIFY DOOR THICKNESS AT TIME OF ORDER

Glass door handle fixing options

Code: A2

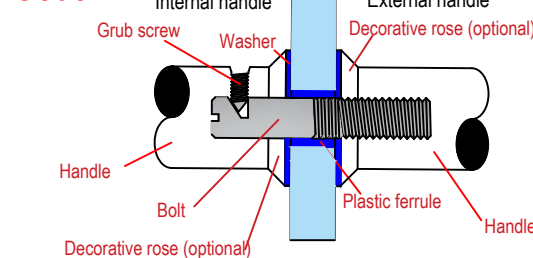

A2 - Back to back fixing for glass (AP) doors.
Thread = M12 (M6 grub screw)
Hole Prep = 18mm dia. (to incorporate nylon ferrule)
PLEASE SPECIFY DOOR THICKNESS AT TIME OF ORDER

Code: A5

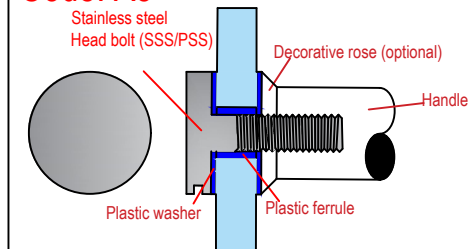

A5 - Stainless steel head decorative bolt for fixing single handles.
Thread = M12
Hole prep = 18mm dia. (to incorporate nylon ferrule).

Code: A6A

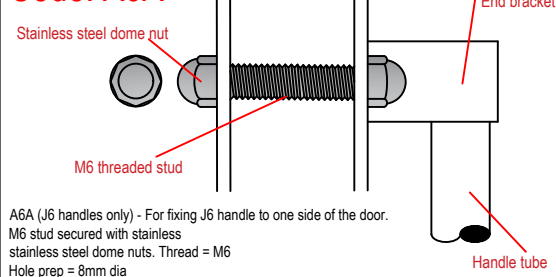

A6A (J6 handles only) - For fixing J6 handle to one side of the door.
M6 stud secured with stainless steel dome nuts. Thread = M6
Hole prep = 8mm dia

Code: A6B

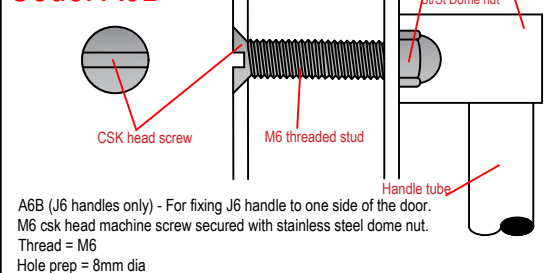

A6B (J6 handles only) - For fixing J6 handle to one side of the door.
M6 csk head machine screw secured with stainless steel dome nut.
Thread = M6
Hole prep = 8mm dia

Code: A8

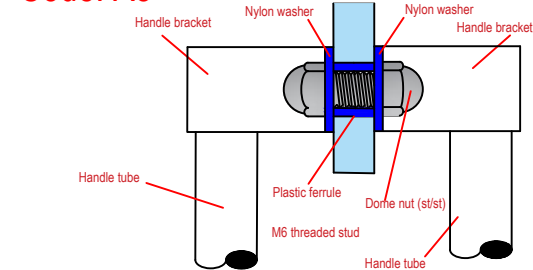

A8 (J6 handles only) - Stainless steel head decorative bolt for single side fixed handles.
Thread M12
Hole prep - 18mm dia.

Code: A11

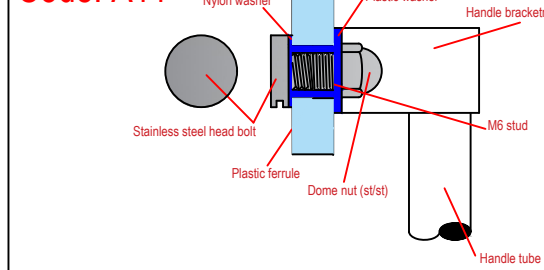

A11 (J6 handles only) - handles fixed back to back by means of an M6 threaded stud secured with stainless steel dome nuts
Thread M6
Hole prep = 18mm dia.

Code: A9

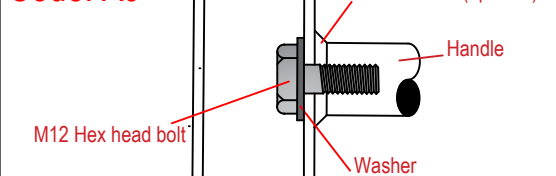

A9 - Single side (secret) fixing for use when bolt through fixing applications are not suitable i.e. when panic hardware is fitted to aluminium doors. Access to the glazing rebate is required prior to installation.
Thread - M12
Hole prep = 13mm dia

Code: A12

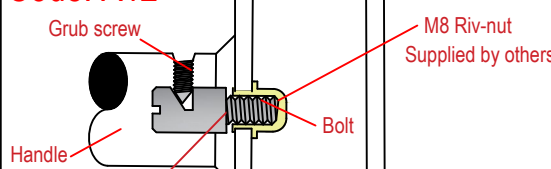

A12 - Single side fixing by means of M8 bolt screwed into riv-nut in metal door (M6 grub screw)
(RIV-NUTS SUPPLIED BY OTHERS)

For handle care and maintenance information and details of our warranty please consult our website (www.j2hardware.com). Information and how to care for our handles will be sent with each order.

Scale: NTS	Date:	Drawn by: JP	
Title: Handle fixing options			
J2 Hardware Ltd. Unit J, Atlas Mill Road, Brighouse, HD6 1ES. Tel: 01484 722171 Email: sales@j2hardware.com			
Registered in England & Wales No. 9596822			