

**Pump Data**

- SH10 HP 8-27/64 Imp, 1 Stage Centrifugal Pump
- 316L SS Corrosion Resistance Construction
- Built-In Overload , Auto-Reset Provided
- 45amp 230V Single Phase UL Motor
- \*110V not available
- 2 F NPT Suction

**Pump Flow**

( not for certification use )

GPM	0	40	60	80	100	150
PSI	113	107	103	95	86	59

**Components**

**Model F-SH102-D**

- A - Flow Switch
- B - 1-1/2 Galvanized Riser F NPT
- C - Supervised Control Valve
- D - Pressure Gauge
- E - D Panel Control Box with Full Steel Frame
- F - 40 60 Pressure Switch
- G - Bypass Line w/ 3/4 Backflow Preventer
- H - SH 10 HP UL Motor w/Pump
- \*Wiring in Liquid Tight Conduit (not shown)

**Check Box for Optional Equipment**

- I - Butterball Tamper Switch

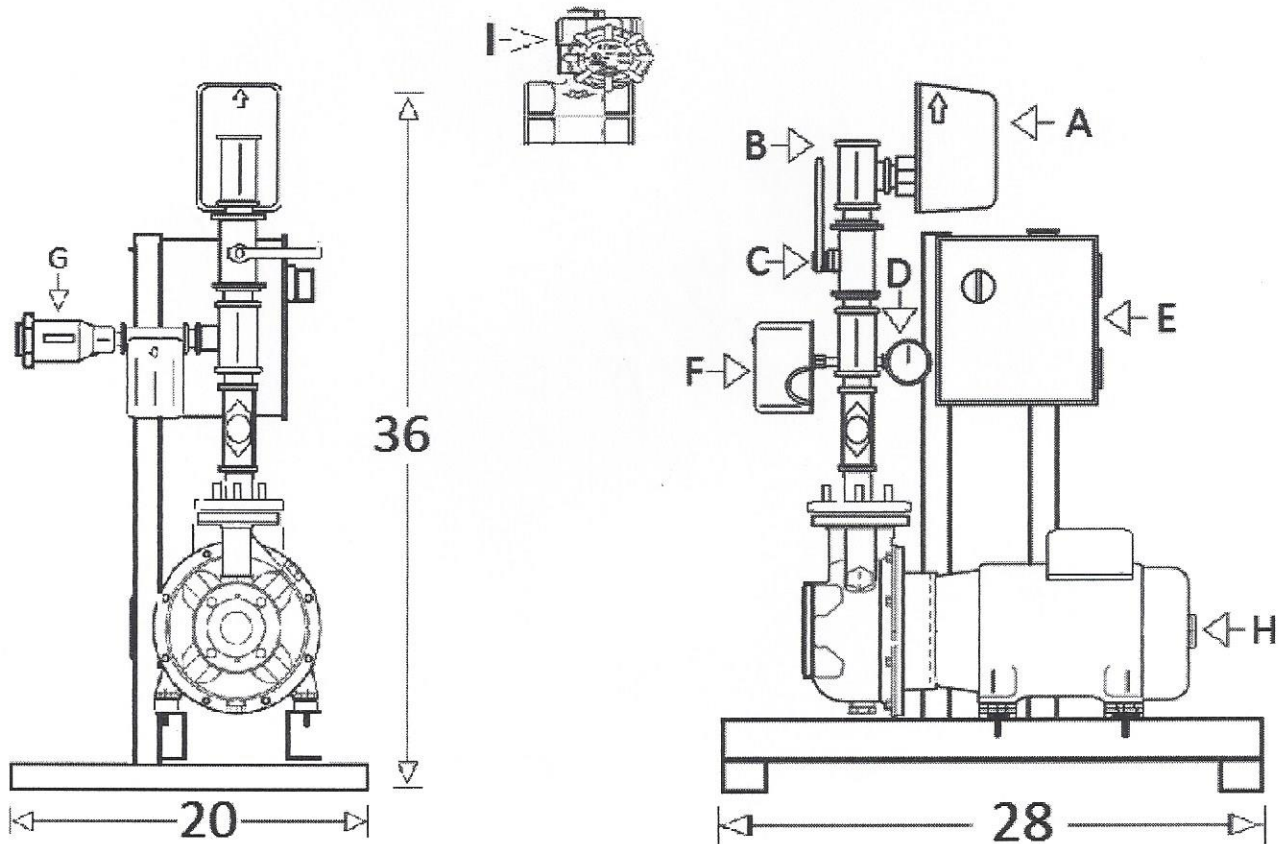

\*Note: all measurement in inches